



NAVAL POSTGRADUATE SCHOOL

MONTEREY, CALIFORNIA

Riverine Sustainment 2012

by

Michael F. Galli
James M. Turner
Kristopher A. Olson
Michael G. Mortensen
Neil D. Wharton
Everett C. Williams
Thomas F. Schmitz
Matthew C. Mangaran
Gil Nachmani

Cheng Hwee Kiat
Goh Choo Seng
Ho Chee Leong
Hui Kok Meng
Lim Han Leong
Lim Meng Hwee
Mak Wai Yen
Phua Poh Sim
Ong Hsueh Min

Eric L. Pond
Joshua G. Sundram
Tan Boon Leng
Tan Kian Moh
Teng Choon Hon
Yow Thiam Poh
Ong Wing Shan

June 2007

Approved for public release; distribution is unlimited

THIS PAGE INTENTIONALLY LEFT BLANK

**NAVAL POSTGRADUATE SCHOOL
Monterey, California 93943-5001**

Daniel T. Oliver, VADM, USN (Ret)
President

Leonard A. Ferrari
Provost

This report was prepared for the Meyer Institute of Systems Engineering, Naval Postgraduate School, 777 Dyer Rd., Monterey, CA 93943.

Reproduction of all or part of this report is authorized.

This report was prepared by Systems Engineering and Analysis Cohort Eleven (SEA-11):

CDR Michael F. Galli (USN)
LT James M. Turner (USN)
LT Kristopher A. Olson (USN)
LT Michael G. Mortensen (USN)
LT Neil D. Wharton (USN)
CPT Everett C. Williams (USA)
ENS Thomas F. Schmitz (USN)
ENS Matthew C. Mangaran (USN)
LT Eric L. Pond (USN)
MAJ Mak Wai Yen (SNA)
CPT Phua Poh Sim (SNA)
CPT Teng Choon Hon Adrian (SNA)
CPT Yow Thiam Poh (SNA)

Cheng Hwee Kiat
Goh Choo Seng
CPT Ho Chee Leong (SNA)
Hui Kok Meng
Lim Han Leong
CPT Gil Nachmani (IDF)
Lim Meng Hwee
Ong Hsueh Min
Ong Wing Shan
CPT Joshua G. Sundram (SNA)
MAJ Tan Boon Leng (RSN)
Tan Kian Moh Terence

Reviewed by:

EUGENE P. PAULO, Ph.D.
SEA-11 Project Advisor

PAUL SHEBALIN, RADM, USNR
SEA-11 Project Advisor

WAYNE P. HUGHES, Jr., CAPT, USN (RET)
Chair, Systems Engineering and Analysis
Curriculum Committee

Released by:

Dan C. Boger, Ph.D.
Associate Provost and Dean of Research

**NAVAL POSTGRADUATE SCHOOL
Monterey, California 93943-5001**

Daniel T. Oliver, VADM, USN (Ret)
President

Leonard A. Ferrari
Provost

This report was prepared for the Meyer Institute of Systems Engineering, Naval Postgraduate School, 777 Dyer Rd., Monterey, CA 93943.

Reproduction of all or part of this report is authorized.

This report was prepared by Systems Engineering and Analysis Cohort Eleven (SEA-11):

CDR Michael F. Galli (USN)
LT James M. Turner (USN)
LT Kristopher A. Olson (USN)
LT Michael G. Mortensen (USN)
LT Neil D. Wharton (USN)
CPT Everett C. Williams (USA)
ENS Thomas F. Schmitz (USN)
ENS Matthew C. Mangaran (USN)
LT Eric L. Pond (USN)
MAJ Mak Wai Yen (SNA)
CPT Phua Poh Sim (SNA)
CPT Teng Choon Hon Adrian (SNA)
CPT Yow Thiam Poh (SNA)

Cheng Hwee Kiat
Goh Choo Seng
CPT Ho Chee Leong (SNA)
Hui Kok Meng
Lim Han Leong
CPT Gil Nachmani (IDF)
Lim Meng Hwee
Ong Hsueh Min
Ong Wing Shan
CPT Joshua G. Sundram (SNA)
MAJ Tan Boon Leng (RSN)
Tan Kian Moh Terence

Reviewed by:

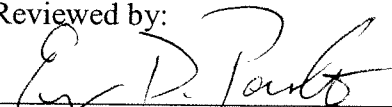
EUGENE P. PAULO, Ph.D.
SEA-11 Project Advisor

PAUL SHEBALIN, RADM, USNR
SEA-11 Project Advisor

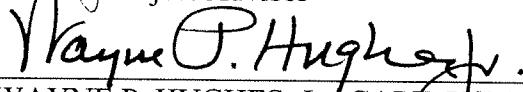
WAYNE P. HUGHES, Jr., CAPT, USN (RET)
Chair, Systems Engineering and Analysis
Curriculum Committee

Released by:

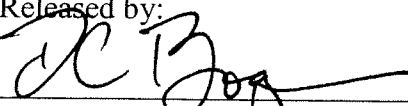
Dan C. Bogert, Ph.D.
Associate Provost and Dean of Research

THIS PAGE INTENTIONALLY LEFT BLANK

REPORT DOCUMENTATION PAGE			Form Approved OMB No. 0704-0188
Public reporting burden for this collection of information is estimated to average 1 hour per response, including the time for reviewing instruction, searching existing data sources, gathering and maintaining the data needed, and completing and reviewing the collection of information. Send comments regarding this burden estimate or any other aspect of this collection of information, including suggestions for reducing this burden, to Washington headquarters Services, Directorate for Information Operations and Reports, 1215 Jefferson Davis Highway, Suite 1204, Arlington, VA 22202-4302, and to the Office of Management and Budget, Paperwork Reduction Project (0704-0188) Washington DC 20503.			
1. AGENCY USE ONLY (Leave blank)	2. REPORT DATE June 2007	3. REPORT TYPE AND DATES COVERED Technical Report	
4. TITLE AND SUBTITLE: Riverine Sustainment 2012		5. FUNDING NUMBERS	
6. AUTHOR(S) Michael Galli, James Turner, Kristopher Olson, Michael Mortensen, Everett Williams, Thomas Schmitz, Matthew Mangaran, Eric Pond, Gil Nachmani, Cheng Hwee Kiat, Goh Choo Seng, Ho Chee Leong, Hui Kok Meng, Lim Han Leong, Lim Meng Hwee, Mak Wai Yen, Ong Hsueh Min, Joshua Sundram, Tan Boon Leng, Tan Kian Moh, Teng Choon Hon, Yow Thiam Poh, Phua Poh Sim, Ong Wing Shan			
7. PERFORMING ORGANIZATION NAME(S) AND ADDRESS(ES) Naval Postgraduate School Monterey, CA 93943-5000		8. PERFORMING ORGANIZATION REPORT NUMBER NPS-SEA-07-001	
9. SPONSORING /MONITORING AGENCY NAME(S) AND ADDRESS(ES) N/A		10. SPONSORING/MONITORING AGENCY REPORT NUMBER	
11. SUPPLEMENTARY NOTES: The views expressed in this report are those of the author and do not reflect the official policy or position of the Department of Defense or the U.S. Government.			
12a. DISTRIBUTION / AVAILABILITY STATEMENT Approved for public release; distribution is unlimited.		12b. DISTRIBUTION CODE A	
13. ABSTRACT (maximum 200 words) This technical report analyzed the Navy's proposed Riverine Force (RF) structure and capabilities for 2012. The Riverine Sustainment 2012 Team (RST) examined the cost and performance of systems of systems which increased RF sustainment in logistically barren environments. RF sustainment was decomposed into its functional areas of supply, repair, and force protection. The functional and physical architectures were developed in parallel and were used to construct an operational architecture for the RF. The RST used mathematical, agent-based and queuing models to analyze various supply, repair and force protection system alternatives. Extraction of modeling data revealed several key insights. Waterborne heavy lift connectors such as the LCU-2000 are vital in the re-supply of the RF when it is operating up river in a non-permissive environment. Airborne heavy lift connectors such as the MV-22 were ineffective and dominated by the waterborne variants in the same environment. Increase in manpower and facilities did appreciable add to the operational availability of the RF. Mean supply response time was the biggest factor affecting operational availability and should be kept below 24 hours to maintain operational availability rates above 80%. Current mortar defenses proposed by the RF are insufficient.			
14. SUBJECT TERMS riverine, sustainment, repair, force protection, supply, communications, forward operating base, mobile operating base, global fleet station			15. NUMBER OF PAGES 544
			16. PRICE CODE
17. SECURITY CLASSIFICATION OF REPORT Unclassified	18. SECURITY CLASSIFICATION OF THIS PAGE Unclassified	19. SECURITY CLASSIFICATION OF ABSTRACT Unclassified	20. LIMITATION OF ABSTRACT UL

THIS PAGE INTENTIONALLY LEFT BLANK

TABLE OF CONTENTS

1.	INTRODUCTION.....	1
	1.1 BACKGROUND	1
	1.1.1 Countering the New Threat	2
	1.1.2 Sustainment Definition	3
	1.1.3 Historical Analysis	7
	1.2 PURPOSE.....	8
	1.3 SCOPE	10
	1.4 REGIONAL CHARACTERISTICS.....	13
	1.4.1 Economy.....	13
	1.4.2 Geography	14
	1.4.3 Climate and Weather.....	15
	1.5 PHYSICAL BASING ALTERNATIVES.....	15
	1.5.1 Forward Operating Base (FOB).....	17
	1.5.2 Mobile Operating Base (MOB).....	17
	1.5.3 Global Fleet Station (GFS).....	18
	1.6 METHODOLOGY	19
	1.6.1 System Engineering	19
	1.6.2 Systems Architecture.....	21
	1.6.3 Joint Capabilities Integration and Development System.....	24
	1.6.4 RST Systems Engineering Design Process.....	25
	1.6.5 Project Management Plan.....	25
	1.7 ASSUMPTIONS.....	27
2.	OPERATIONAL CONCEPT	35
	2.1 OVERVIEW	35
	2.2 OPERATIONAL PHASES	38
	2.2.1 Pre-Deployment Phase.....	39
	2.2.2 Deployment Phase.....	39
	2.2.3 Employment Phase.....	41
	2.2.4 Withdrawal Phase.....	43
	2.3 RIVERINE SCENARIO	44
	2.3.1 Mission	44
	2.3.2 Situation.....	45
	2.3.3 Considerations Affecting Possible Courses of Action.....	47
	2.3.3.1 Terrain and Geography	47
	2.3.3.2 Hydrography.....	48
	2.3.3.3 Transportation.....	48
	2.3.3.4 Enemy Relative Combat Power	50
	2.3.3.5 Friendly Relative Combat Power.....	51
	2.3.3.6 Assumptions, Constraints, and Other Considerations.....	52
	2.3.4 Basic Conduct of Maritime Interdiction Operations.....	53
	2.3.4 Enemy Courses of Action (ECOAs).....	55
	2.3.4.1 ECOA 1 Cease or Reroute Operations	55

	2.3.4.2 <i>ECOA 2 Employ Decoys and Harassment</i>	55
	2.3.4.3 <i>ECOA 3 Engagement of Forces</i>	55
3.	FUNCTIONAL ARCHITECTURE	59
3.1	FUNCTIONAL ARCHITECTURE COMPONENTS AND PURPOSE ..	59
	3.1.1 Initial Problem Statement	60
3.2	STAKEHOLDER ANALYSIS	61
	3.2.1 Stakeholders	61
	3.2.2 Stakeholder Input	62
	3.2.3 Core Documentation	62
3.3	SYSTEM DECOMPOSITION	63
	3.3.1 Supply Group	63
	3.3.1.1 <i>Functions</i>	64
	3.3.1.2 <i>Components</i>	64
	3.3.1.3 <i>Hierarchical Structure</i>	65
	3.3.1.4 <i>States</i>	65
	3.3.2 Repair Group	65
	3.3.2.1 <i>Functions</i>	66
	3.3.2.2 <i>Components</i>	67
	3.3.2.3 <i>Hierarchical Structure</i>	67
	3.3.2.4 <i>States</i>	67
	3.3.3 Force Protection Group	67
	3.3.3.1 <i>Functions</i>	68
	3.3.3.2 <i>Components</i>	69
	3.3.3.3 <i>Hierarchical Structure</i>	69
	3.3.3.4 <i>States</i>	70
3.4	INPUT-OUTPUT MODEL	70
	3.4.1 Supply Group	71
	3.4.2 Repair Group	72
	3.4.3 Force Protection Group	75
3.5	FUNCTIONAL HIERARCHY	77
	3.5.1 Supply Group	79
	3.5.1.1 <i>Maintain</i>	80
	3.5.1.2 <i>Movement</i>	83
	3.5.1.3 <i>Bring Back</i>	84
	3.5.2 Repair Group	86
	3.5.3 Force Protection Group	89
3.6	FUNCTIONAL FLOW DIAGRAM AND CONTEXT MODEL	91
	3.6.1 Supply Group	91
	3.6.2 Repair Group	95
	3.6.3 Force Protection Group	97
3.7	REVISED PROBLEM STATEMENT	99
3.8	OBJECTIVES HIERARCHY AND METRICS	100
	3.8.1 Supply Group	100
	3.8.1.1 <i>Maintain</i>	101
	3.8.1.2 <i>Movement</i>	115

	3.8.1.3 <i>Bring Back</i>	123
	3.8.1.4 <i>Operational Feasibility</i>	130
	3.8.1.5 <i>Overall Supply Evaluation Measures</i>	132
3.8.2	Repair Group	134
	3.8.2.1 <i>Managing Personnel</i>	136
	3.8.2.2 <i>Repairing the Fleet</i>	136
3.8.3	Force Protection Group	136
4.	PHYSICAL ARCHITECTURE	153
4.1	PHYSICAL ARCHITECTURE COMPONENTS AND PURPOSE	153
4.2	NAVAL EXPEDITIONARY COMMAND ELEMENTS	154
4.3	RIVERINE SQUADRON ELEMENTS	157
4.4	ADAPTIVE FORCE PACKAGES	158
4.5	BASING ALTERNATIVES	159
	4.5.1 Forward Operating Base	159
	4.5.2 Mobile Operating Base	163
	4.5.2.1 <i>Analysis of Alternatives</i>	<i>163</i>
	4.5.2.2 <i>Feasibility Analysis</i>	<i>173</i>
	4.5.2.3 <i>Risk Analysis</i>	<i>177</i>
	4.5.3 Global Fleet Station	178
	4.5.4 Supply System	181
	4.5.4.1 <i>Feed Plan</i>	<i>182</i>
	4.5.4.2 <i>Fuel Plan</i>	<i>185</i>
	4.5.4.3 <i>Water Plan</i>	<i>186</i>
	4.5.4.4 <i>Ammunition Plan</i>	<i>187</i>
	4.5.4.5 <i>Repair Plan</i>	<i>189</i>
	4.5.4.6 <i>Waste Plan</i>	<i>189</i>
	4.5.4.7 <i>Physical Flow</i>	<i>190</i>
4.6	SUPPLY GROUP	192
	4.6.1 Analysis of Alternatives	192
	4.6.1.1 <i>Landing Craft Air Cushion (LCAC)</i>	<i>193</i>
	4.6.1.2 <i>Landing Craft Utility (LCU) 1610 Class</i>	<i>195</i>
	4.6.1.3 <i>Landing Craft Mechanized (LCM)</i>	<i>197</i>
	4.6.1.4 <i>Landing Craft Utility (LCU) 2000 Class</i>	<i>198</i>
	4.6.1.5 <i>SEACOR Marine 126' MiniSupply Jim G</i>	<i>200</i>
	4.6.1.6 <i>150' Crew/Fast Support Vessel Sharon F</i>	<i>201</i>
	4.6.1.7 <i>H-60 Helicopter</i>	<i>203</i>
	4.6.1.8 <i>H-53E Super Stallion/Sea Dragon Helicopter</i>	<i>204</i>
	4.6.1.9 <i>MV-22 Osprey</i>	<i>205</i>
	4.6.2 Feasibility Analysis	206
	4.6.3 Risk Analysis	208
	4.6.4 Logistic Connector Configuration	209
4.7	REPAIR GROUP	210
	4.7.1 Analysis of Alternatives	210
	4.7.2 Feasibility Analysis	212
	4.7.3 Risk Analysis	214

4.8	FORCE PROTECTION GROUP	216
4.8.1	Analysis of Alternatives	216
4.8.1.1	<i>Sensors</i>	219
4.8.1.2	<i>Weapons</i>	225
4.8.1.3	<i>Barriers</i>	228
4.8.1.4	<i>Carrier Platforms</i>	231
4.8.1.5	<i>Physical Architectures and Their Employment</i>	235
4.8.2	Feasibility Analysis	240
4.8.3	Risk Analysis	240
5.	MODELING OVERVIEW	257
5.1	MODELING PURPOSE AND COMPONENTS	257
5.2	SUPPLY GROUP	258
5.2.1	SIMKIT Software	258
5.2.2	SIMKIT Set-up	259
5.2.3	SIMKIT Data Outputs	261
5.2.3.1	<i>Metrics for Supply Ship</i>	261
5.2.3.2	<i>Metrics for Operating Base</i>	262
5.2.3.3	<i>Metrics for Supply Craft</i>	263
5.2.4	SIMKIT Software Processes, Assumptions and Limitations	263
5.2.4.1	<i>SeaSupplyCraftCreator Listener Object</i>	264
5.2.4.2	<i>SeaSupplyScheduler Listener Object</i>	265
5.2.4.3	<i>SeaSupplyCraftDepot Listener Object</i>	266
5.2.4.4	<i>SupplyStation Listener Object</i>	266
5.2.4.5	<i>Travel Manager Listener Object</i>	267
5.2.4.6	<i>OperatingBase Listener Object</i>	268
5.2.5	SIMKIT Assumptions	270
5.2.5.1	<i>Simulation</i>	270
5.2.5.2	<i>Supply Ship</i>	270
5.2.5.3	<i>Supply Status</i>	270
5.2.5.4	<i>Supply Connector</i>	270
5.2.5.5	<i>Supply Connector Depot</i>	270
5.2.5.6	<i>Operating Base</i>	271
5.2.6	SIMKIT Limitations	271
5.2.6.1	<i>Simulation</i>	271
5.2.6.2	<i>Supply Ship</i>	271
5.2.6.3	<i>Supply</i>	272
5.2.7	EXTEND Model	272
5.2.7.1	<i>Software</i>	272
5.2.7.2	<i>Set Up</i>	272
5.2.7.3	<i>Data Outputs</i>	288
5.2.7.4	<i>Software Processes and Limitations</i>	289
5.3	REPAIR GROUP	291
5.3.1	Software and Setup	291
5.3.2	Data Outputs	296
5.3.3	Software Processes, Assumptions and Limitations	298

5.4	FORCE PROTECTION GROUP	298
5.4.1	Software	298
5.4.1.1	<i>MANA</i>	298
5.4.1.2	<i>MATLAB</i>	299
5.4.2	MANA Software Setup	299
5.4.3	Scenario 1: Mortar Attack on the FOB	300
5.4.3.1	<i>Scenario 1A: Mortar Defense (baseline defense)</i>	302
5.4.3.2	<i>Scenario 1B: MORTAR DEFENSE (with UAV and mortar fire support)</i>	303
5.4.3.3	<i>Scenario 1C: MORTAR DEFENSE (with counter-fire radar, mortar fire support)</i>	304
5.4.3.4	<i>Scenario 1D: MORTAR DEFENSE (with counter-fire ground radar, mortar fire support and UAV)</i>	304
5.4.4	Scenario 2: Ground RAID ON FOB	305
5.4.4.1	<i>Scenario 2A: GROUND RAID ON FOB (baseline security)</i>	306
5.4.4.2	<i>Scenario 2B: GROUND RAID ON FOB (with Sensor fence and Mortar)</i>	308
5.4.4.3	<i>Scenario 2C: GROUND RAID ON FOB (with remote turret)</i>	309
5.4.5	Scenario 3: BOAT ATTACK ON FOB	309
5.4.5.1	<i>Scenario 3A: BOAT ATTACK ON FOB (baseline defense)</i>	311
5.4.5.2	<i>Scenario 3B: BOAT ATTACK ON FOB (baseline defense and floating barrier)</i>	311
5.4.5.3	<i>Scenario 3C: BOAT ATTACK ON FOB (floating barrier and ROSAM)</i>	312
5.4.5.4	<i>Scenario 3D: BOAT ATTACK ON FOB (with baseline defense, floating barrier, and patrol boat)</i>	312
5.4.5.5	<i>Scenario 3E: BOAT ATTACK ON FOB (ROSAM, floating barrier, and patrol boat)</i>	313
5.4.6	Scenario 4: BOAT ATTACK ON MOB	313
5.4.6.1	<i>Scenario 4A: BOAT ATTACK ON MOB (RCSS Baseline)</i>	314
5.4.6.2	<i>Scenario 4B: BOAT ATTACK ON MOB (RCSS baseline with Patrol Boat (PB))</i>	315
5.4.6.3	<i>Scenario 4C: BOAT ATTACK ON MOB (Nobriza and Barge baseline)</i>	316
5.4.6.4	<i>Scenario 4D: BOAT ATTACK ON MOB (Nobriza and Barge baseline with barrier and PB)</i>	317
5.4.7	MATLAB	317
5.4.7.1	<i>Method</i>	318
5.4.7.2	<i>Matlab Definitions</i>	318
5.4.7.3	<i>Main assumptions</i>	319
5.4.7.4	<i>MATLAB Model</i>	320
6.	COST ESTIMATION	329

6.1	COST ESTIMATE PURPOSE AND COMPONENTS	329
6.2	SUPPLY GROUP.....	330
6.3	REPAIR GROUP.....	333
6.4	FORCE PROTECTION GROUP	336
6.4.1	Mortar Alternatives.....	337
6.4.2	Commando Raid	338
6.4.3	FOB Boat Attack.....	340
6.4.4	MOB Boat Attack	341
6.5	MOBILE OPERATING BASE	342
7.	ANALYSIS AND RESULTS	351
7.1	SUPPLY GROUP ASSUMPTIONS AND LIMITATIONS	351
7.1.1	SIMKIT Assumptions.....	351
7.1.1.1	<i>Three Types of Operating Base</i>	<i>351</i>
7.1.1.2	<i>Four Types of Supply Connectors.....</i>	<i>351</i>
7.1.1.3	<i>Number of Configurations (Combinations of Supply Connectors)</i>	<i>351</i>
7.1.2	SIMKIT Limitations.....	352
7.1.3	SIMKIT Analysis of FOB.....	353
7.1.3.1	<i>Supply Ship On-Station Time</i>	<i>353</i>
7.1.3.2	<i>Operating Base Supply Level.....</i>	<i>356</i>
7.1.3.3	<i>Data Normalization.....</i>	<i>358</i>
7.1.3.4	<i>Cost Performance.....</i>	<i>360</i>
7.1.4	SIMKIT Analysis of MOB1	362
7.1.4.1	<i>Supply Ship On-Station Time</i>	<i>362</i>
7.1.4.2	<i>Operating Base Supply Level.....</i>	<i>365</i>
7.1.4.3	<i>Data Normalization.....</i>	<i>367</i>
7.1.4.4	<i>Cost Performance.....</i>	<i>369</i>
7.1.5	SIMKIT Analysis of MOB2	371
7.1.5.1	<i>Supply Ship On-Station Time</i>	<i>371</i>
7.1.5.2	<i>Operating Base Supply Level.....</i>	<i>375</i>
7.1.5.3	<i>Data Normalization.....</i>	<i>377</i>
7.1.5.4	<i>Cost Performance.....</i>	<i>379</i>
7.1.6	Supply Software EXTEND Processes, Assumptions and Limitations.....	380
7.1.6.1	<i>Assumptions</i>	<i>380</i>
7.1.7	EXTEND Analysis	381
7.1.7.1	<i>Operational Availability of SURC's due to Fuel (A_o fuel SURC).....</i>	<i>381</i>
7.1.7.2	<i>Operational Habitability of Base due to food and water (A_o food & Water Base)</i>	<i>386</i>
7.1.7.3	<i>Average number of lost logistic connectors during operation.....</i>	<i>391</i>
7.1.8	EXTEND Cost Performance.....	396
7.2	REPAIR GROUP.....	398
7.3	FORCE PROTECTION GROUP	400

7.3.1	Revised Measures of Performance	400
7.3.1.1	<i>Time of enemy casualty</i>	401
7.3.1.2	<i>Number of Enemy Hits on a Single Entity</i>	402
7.3.1.3	<i>The Force Exchange Ratio</i>	402
7.3.1.4	<i>Number of Enemy Penetrations</i>	403
7.3.1.5	<i>Mean Distance of Enemy Casualties</i>	403
7.3.1.6	<i>Number of RF casualties</i>	403
7.3.1.7	<i>Number of SURC's Destroyed</i>	403
7.3.2	Statistical Comparison of MOP's and Raw Data Matrices	404
7.3.2.1	<i>Mortar MOP Results and Statistical Analysis</i>	405
7.3.2.2	<i>Commando Raid MOP Results and Statistical Analysis</i>	408
7.3.2.3	<i>Boat Attack on FOB Results and Statistical Analysis</i>	410
7.3.2.4	<i>Boat Attack on MOB Results and Statistical Analysis</i>	414
7.3.3	Raw Data Matrices, Alternative Rankings, and Sensitivity Analysis	418
7.3.3.1	<i>Mortar Defense Alternatives</i>	419
7.3.3.2	<i>Commando Raid on FOB</i>	420
7.3.3.3	<i>FOB Boat Attack Alternatives</i>	422
7.3.3.4	<i>MOB Boat Attack Alternatives</i>	423
7.3.3.5	<i>MANA Results</i>	424
7.3.4	Cost Performance Curves	426
8.	CONCLUSIONS AND RECOMMENDATIONS.....	433
8.1	SUPPLY GROUP.....	433
8.2	REPAIR GROUP.....	434
8.3	FORCE PROTECTION GROUP	435
9.	AREAS OF FURTHER STUDY	437
APPENDIX A:	LIST OF REFERENCES	441
APPENDIX B:	TASKING LETTER FROM MEYER INSTITUTE	453
APPENDIX C:	ACRONYMS	459
APPENDIX D:	SURC FUEL CONSUMPTION AND ENGINE OPERATING HOUR CALCULATIONS	461
1.	BACKGROUND	461
2.	SETUP.....	462
3.	RESULTS	464
APPENDIX E:	A STUDY INTO THE POTENTIAL FOR WIRELESS TECHNOLOGIES AS AN ALTERNATIVE COMMUNICATIONS ARCHITECTURE FOR RIVERINE FORCES.	467
1.	INTRODUCTION.....	467
2.	PROBLEM DEFINITION	472
3.	DESIGN AND ANALYSIS PHASE	483
4.	CONCLUSIONS	508
5.	RECOMMENDATIONS FOR FURTHER RESEARCH	509

INITIAL DISTRIBUTION LIST514

LIST OF FIGURES

Figure 1.	RST Breakdown.....	12
Figure 2.	FOB in Iraq.....	17
Figure 3.	Columbian MOB, Nobriza.....	18
Figure 4.	The San Antonio Class (LPD-17).....	19
Figure 5.	An Analytical Framework Used Throughout the Systems Engineering and Analysis Process.	21
Figure 6.	Systems Architecture.....	22
Figure 7.	Alternate operational concepts for Apollo’s moon landing.....	23
Figure 8.	RST Project Cycle.....	27
Figure 9.	US Military Operations Spectrum.....	36
Figure 10.	U.S. Operating Phases.....	37
Figure 11.	Amphibious Deployment Operations.....	41
Figure 12.	Troop Withdrawal.....	44
Figure 13.	U.S. Riverine Force Area of Operations.....	45
Figure 14.	Kampar Region Terrain Features.....	48
Figure 15.	Typical Local Merchant Ships.....	49
Figure 16.	Typical Small Cargo Ship.....	50
Figure 17.	Approximate Insurgent Strength and Locations.....	51
Figure 18.	MIO Search Site.....	54
Figure 19.	RST Stakeholder Map.....	61
Figure 20.	Riverine Force Decomposition.....	64
Figure 21.	Maintenance System Decomposition.....	66
Figure 22.	FP Decomposition.....	68
Figure 23.	RF Supply Input-Output Model.....	71
Figure 24.	Repair Input-Output Model.....	73
Figure 25.	Force Protection System Input Output Model.....	75
Figure 26.	Riverine Force Functional Hierarchy.....	77
Figure 27.	Supply Functional Hierarchy.....	80
Figure 28.	Maintain Functional Hierarchy.....	80
Figure 29.	Movement Functional Hierarchy.....	83
Figure 30.	Bring Back Functional Hierarchy.....	85
Figure 31.	Repair Group Functional Hierarchy.....	87
Figure 32.	Force Protection System Functional Hierarchy.....	89
Figure 33.	RST Supply Functional Flow Block Diagram.....	93
Figure 34.	Maintenance Functional Flow Block Diagram.....	96
Figure 35.	Force Protection Functional Flow Block Diagram.....	98
Figure 36.	Top Level Supply Objectives Hierarchy.....	101
Figure 37.	Maintain Objectives Hierarchy.....	103
Figure 38.	Movement Objectives Hierarchy.....	117
Figure 39.	Bring Back Objectives Hierarchy.....	124
Figure 40.	Logistics Connector Operational Feasibility.....	131
Figure 41.	Maintenance Objective Hierarchy.....	135
Figure 42.	Top-level Functions and Objectives for the FPS.....	137

Figure 43.	Predicting Threat Objectives Hierarchy.....	138
Figure 44.	Deterrence Objectives Hierarchy	139
Figure 45.	Denial Objectives Hierarchy.....	141
Figure 46.	FPS System Suitability	143
Figure 47.	NECC Functions and Capabilities	155
Figure 48.	NECC Support of the JFMCC Environment	156
Figure 49.	Forward Operating Base Configuration.....	160
Figure 50.	Lockheed Martin LCS.....	164
Figure 51.	General Dynamics LCS.	165
Figure 52.	HSV.....	166
Figure 53.	Logistic Support Vessel (LSV).....	167
Figure 54.	The RCSS.....	168
Figure 55.	APB-39 Mercer in support of Mobile Riverine Forces.	169
Figure 56.	The Nobriza	170
Figure 57.	RSS-207 Endurance	171
Figure 58.	LST-839 Iredell County.....	172
Figure 59.	LST-1192 Spartanburg County.....	173
Figure 60.	GFS Alternative the Wasp Class (LHD-1)	180
Figure 61.	Delivery Service Options of the RF.....	191
Figure 62.	Return Service Options of the RF.....	192
Figure 63.	Landing Craft Air Cushion (LCAC).....	193
Figure 64.	Landing Craft Utility (LCU) 1610 Class	195
Figure 65.	Landing Craft Mechanized (LCM-8).....	197
Figure 66.	Landing Craft Utility (LCU) 2000 Class	198
Figure 67.	MiniSupply Jim G by SEACOR Marine.	200
Figure 68.	Crew/Fast Support Vessel Sharon F by SEACOR Marine.....	201
Figure 69.	SH-60 Seahawk.....	203
Figure 70.	H-53E.....	204
Figure 71.	MV-22.....	205
Figure 72.	2006 SURC RMA Report Percent of Failures by System	213
Figure 73.	SensorFence	220
Figure 74.	ThermoVision Sentry II	222
Figure 75.	FLIR’s SeaFLIR III.....	222
Figure 76.	Mk 46 MOD 1.....	223
Figure 77.	The AN/SPS-67 Radar.....	224
Figure 78.	The Lightweight Counter-Mortar Radar (LCMR).....	225
Figure 79.	M120 120 mm Mortar.....	227
Figure 80.	Precision Guided Mortar Munition (PGMM).....	228
Figure 81.	Triple Concertina Wire Fence.....	229
Figure 82.	Berm Configuration	229
Figure 83.	Configurations of enhanced Whisper Wave Models	230
Figure 84.	The Rapid Deployment Fortification Wall	231
Figure 85.	Light Patrol Boat.....	232
Figure 86.	The Sea Fox USV	233
Figure 87.	Silver Fox UAV	234

Figure 88.	Mk49 MOD 0/ROSAM with M2HB Bushmaster .50 caliber machine gun	234
Figure 89.	Mortar Threat FPS Architectures	235
Figure 90.	Commando Raid FPS	236
Figure 91.	Boat Attack on FOB FPS	237
Figure 92.	RCSS Boat Attack FPS	238
Figure 93.	Nobriza and Barge Boat Attack FPS	239
Figure 94.	Event Graph for SeaSupplyCraftCreator Object	264
Figure 95.	Event Graph for SeaSupplyScheduler Object	265
Figure 96.	Event Graph for SeaSupplyCraftDepot Object	266
Figure 97.	Event Graph for SupplyStation Object	267
Figure 98.	Event Graph for TravelManager Object	268
Figure 99.	Event Graph for OperatingBase Object	269
Figure 100.	Extend hierarchical blocks	289
Figure 101.	RF Maintenance Function Model Block Diagram	291
Figure 102.	SURC Preventive Maintenance Example	292
Figure 103.	2006 SURC RMA Report Percent of Failures by System	293
Figure 104.	Typical failure-rate curve relationships	294
Figure 105.	Mortar Attack Diagram	301
Figure 106.	Raid on FOB Diagram	305
Figure 107.	Boat Attack on FOB Diagram	310
Figure 108.	Boat Attack on MOB Diagram	313
Figure 109.	Procurement and Five Year O&S Cost of Supply Connectors	333
Figure 110.	Procurement and Five Year O&S Costs of MOB Alternatives	346
Figure 111.	FOB – Supply Ship Presence Duration	354
Figure 112.	FOB – Supply Ship Presence Duration	355
Figure 113.	FOB – Operating Base Supply Level	357
Figure 114.	FOB – Operating Base Supply Level	358
Figure 115.	Connector Alternatives Cost Performance Curve for FOB 4-7 Days	360
Figure 116.	Connector Alternatives Cost Performance Curve for FOB 8-9 Days	361
Figure 117.	MOB1 – Supply Ship Presence Duration	363
Figure 118.	MOB1 – Supply Ship Presence Duration	364
Figure 119.	MOB1 – Operating Base Supply Level	366
Figure 120.	MOB1 – Operating Base Supply Level	367
Figure 121.	Connector Alternatives Cost Performance Curve for MOB1 4-7 Days	370
Figure 122.	Connector Alternatives Cost Performance Curve for MOB1 8-9 Days	371
Figure 123.	MOB2 – Supply Ship Presence Duration	373
Figure 124.	MOB2 - Supply Ship Presence Duration	374
Figure 125.	MOB2 – Operating Base Supply Level	376
Figure 126.	MOB2 – Operating Base Supply Level	377
Figure 127.	Connector Alternatives Cost Performance Curve for MOB2 4-7 Days	379
Figure 128.	Connector Alternatives Cost Performance Curve for MOB2 8-9 Days	380
Figure 129.	$A_{o \text{ fuel}}$ SURC for FOB and LCU-2000	383
Figure 130.	$A_{o \text{ fuel}}$ SURC for FOB and SEACOR “Jim G”	384
Figure 131.	$A_{o \text{ fuel}}$ SURC for MOB and LCU-2000	385
Figure 132.	$A_{o \text{ fuel}}$ SURC for MOB and SEACOR “Jim G”	386

Figure 133.	$A_{o \text{ food \& Water}}$ Base for FOB and LCU-2000.	388
Figure 134.	$A_{o \text{ food \& Water}}$ Base for FOB and SEACOR “Jim G”	389
Figure 135.	$A_{o \text{ food \& Water}}$ Base for MOB and LCU-2000	390
Figure 136.	$A_{o \text{ food \& Water}}$ Base for MOB and SEACOR “Jim G”	391
Figure 137.	Lost Connectors using FOB and LCU-2000 configuration as a function of supply ship cycle time.	393
Figure 138.	Lost connectors using the FOB and SEACOR “Jim G” configuration as a function of supply ship cycle time.	394
Figure 139.	Lost connectors using the MOB and LCU-2000 configuration as a function of supply ship cycle time.	395
Figure 140.	Lost connectors using the MOB and SEACOR “Jim G” configuration as a function of supply ship cycle time.	396
Figure 141.	Lost Cost for each configuration of the FOB.	397
Figure 142.	Lost Cost for each configuration of the FOB.	398
Figure 143.	SURC Operational A_o versus MSRT	400
Figure 144.	Time of First Enemy Detection/Enemy Casualty	406
Figure 145.	Number of Hits on FOB.	407
Figure 146.	Force exchange ratio $(B \text{ killed} / B_0) / (R \text{ killed} / R_0)$.	408
Figure 147.	Number of Red Penetrations	409
Figure 148.	Mean distance of Red Casualties	411
Figure 149.	Number of Blue casualties, Excluding SURC’s	412
Figure 150.	Number of SURC’s Destroyed	414
Figure 151.	Mean Distance of Red Casualties	415
Figure 152.	Number of Blue Casualties, excluding SURC’s	416
Figure 153.	Number of SURC’s destroyed	417
Figure 154.	MATLAB Combat Stage Results	425
Figure 155.	Value of IR Sensors	426
Figure 156.	Mortar Defense Cost Performance Curve	427
Figure 157.	Commando Raid Alternatives Cost Performance Curve	428
Figure 158.	FOB Boat Attack Cost Performance Curve	429
Figure 159.	MOB Boat Attack Defense Cost Performance Curve	430

LIST OF TABLES

Table 1.	Classes of Supplies	4
Table 2.	Threat Levels	38
Table 3.	Typical Regional Ship Characteristics.....	49
Table 4.	MOB Feasibility Matrix.....	175
Table 5.	Feasible MOB Information.	176
Table 6.	U.S. Amphibious Ship Capacities.....	181
Table 7.	Most Likely Number of Personnel at Each Basing Alternative.....	182
Table 8.	Minimum, Most Likely, and Maximum Number of Personnel at Each Basing Alternative.	182
Table 9.	15 Day Food Supply for FOB.....	183
Table 10.	Total Amount of Food for 15 Days at MOB1 and MOB2.....	184
Table 11.	Storage at Each of the Basing Alternatives.....	184
Table 12.	Fuel Storage for the Basing Alternatives.....	185
Table 13.	Daily Gallons of Water per Person Required in a Tropical Zone.....	186
Table 14.	Water Storage for Each Basing Alternative.....	187
Table 15.	Number of Armed Personnel at Each Basing Option Likely to Expend Ammunition.....	187
Table 16.	Number of Weapons, Expenditure Rates, and Storage for Each Basing Alternative.....	188
Table 17.	Summary of Repair Parts Needed at All Basing Alternatives.....	189
Table 18.	Amount of Waste Storage at Each Basing Alternative.....	190
Table 19.	Connector Feasibility Matrix.....	207
Table 20.	Summary of Feasible Connectors	207
Table 21.	Types of Risk for Logistic Connectors.....	208
Table 22.	Connector Configurations.....	209
Table 23.	Deny Mortar Threat	216
Table 24.	Denying Commando Raid Threat.....	217
Table 25.	Denying Boat Attack Threat.....	218
Table 26.	Weapon Parameters'.....	228
Table 27.	Types of Risk for the FPS.....	240
Table 28.	Operating Base Parameters.....	259
Table 29.	Supply Craft Parameters.....	259
Table 30.	Supply Connector Mix.....	260
Table 31.	Assumptions, stochastic, and deterministic parameters of model.....	286
Table 32.	Percentage of time effects occur and there effect on the logistic connectors.....	287
Table 33.	SURC Failure and Maintenance Report Excerpt.....	293
Table 34.	SURC Maintenance and Service Plan Excerpt.....	295
Table 35.	SURC Reliability	296
Table 36.	Scenario 1A Setup.....	302
Table 37.	Scenario 1B Setup.....	303
Table 38.	Scenario 1C Setup.....	304
Table 39.	Scenario 1D Setup.....	304

Table 40.	Scenario 2A Setup.....	307
Table 41.	Scenario 2B Setup.....	308
Table 42.	Scenario 2C Setup.....	309
Table 43.	Scenario 3A Setup.....	311
Table 44.	Scenario 3C Setup.....	312
Table 45.	Scenario 3D Setup.....	312
Table 46.	Scenario 4A Setup.....	315
Table 47.	Scenario 4B Setup.....	316
Table 48.	Scenario 4C Setup.....	316
Table 49.	Scenario 4D Setup.....	317
Table 50.	One Year O&S Cost for LCU-1610.....	331
Table 51.	One Year O&S Cost for LCU-2000	331
Table 52.	One Year O&S Cost for Jim G	332
Table 53.	One Year O&S Cost for CH-53E.....	332
Table 54.	Procurement and Five Year O&S Cost for Supply Connectors.....	333
Table 55.	Annual Military Salaries.....	334
Table 56.	Maintenance System Five Year O&S Cost.....	335
Table 57.	Five Year O&S Cost of Repair Alternatives.....	336
Table 58.	Mortar Alternatives Cost Estimation	337
Table 59.	Commando Raid Alternatives Cost Estimation	338
Table 60.	Cost Estimation for FOB Boat Attack Alternatives.....	340
Table 61.	Cost Estimation for MOB Boat Attack Alternatives	341
Table 62.	RCSS Conversion Cost.....	343
Table 63.	One Year O&S Cost for RCSS (LST-1179 Class)	343
Table 64.	One Year O&S Cost for RSS-207 Endurance Class (Estimated from LPD-4).....	344
Table 65.	One Year O&S Cost for a Barge (Estimated from ARL-1).....	345
Table 66.	One Year O&S Cost for Nobriza (Estimated from PC-1)	345
Table 67.	Procurement and Five Year O&S Costs for MOB Alternatives.....	346
Table 68.	Five Year O&S Cost for GFS (LSD-49)	347
Table 69.	Configurations for Supply Connector.....	352
Table 70.	FOB – Supply Ship Presence Duration.....	353
Table 71.	FOB – Operating Base Supply Level.....	356
Table 72.	FOB Supply Level Utility Score for Configurations	359
Table 73.	MOB1 – Supply Ship Presence Duration	362
Table 74.	MOB1 – Operating Base Supply Level	365
Table 75.	MOB1 Supply Level Utility Score for Configurations.....	369
Table 76.	MOB2 – Supply Ship Presence Duration	372
Table 77.	MOB2 – Operating Base Supply Level	375
Table 78.	MOB2 Supply Level Utility Score for Configurations.....	378
Table 79.	$A_{O \text{ fuel}}$ SURC for All Configurations.	382
Table 80.	$A_{O \text{ food \& Water}}$ Base for all configurations.	387
Table 81.	Number of Lost Connectors for each configuration.	392
Table 82.	Repair Raw Data Matrix	399
Table 83.	Force Protection MOP Revisions.....	401

Table 84.	Raw Data Matrix for Mortar Defense Architectures	419
Table 85.	Normalized Data Matrix for Mortar Defense	419
Table 86.	Mortar Defense Utility Scores	420
Table 87.	Raw Data Matrix for Commando Raid Architectures	420
Table 88.	Normalized Data Matrix for Commando Raid Alternatives.....	421
Table 89.	Commando Raid Utility Scores	421
Table 90.	Raw Data Matrix for FOB Boat Attack Architectures.....	422
Table 91.	Normalized Data Matrix for FOB Boat attack.....	422
Table 92.	Utility Score for FOB Boat Attack	423
Table 93.	Raw Data Matrix for MOB Boat Attack Architectures	423
Table 94.	Normalized Data Matrix for MOB Boat attack	423
Table 95.	Utility Score for MOB Boat Attack.....	424

ACKNOWLEDGEMENTS

The students of Systems Engineering and Analysis Cohort Eleven would like to thank the faculty and staff of the Systems Engineering and Analysis Curriculum and the Wayne E. Meyer Institute for their instruction and dedication to excellence in preparing our cohort to complete this technical project.

Captain Evan H. Thompson (USN)

LCDR Frank E. Okata (USN)

Professor Gary Langford

Professor Eugene Paulo

Professor R. Mitchell Brown III

Professor Michael T. McMasters

Professor Mark Stevens

Professor Edouard Kujawski

Mr. Andy Ulak

Additionally, we would like to thank our families for their support and encouragement over the past eighteen months. Without their support, none of this would have been possible.

EXECUTIVE SUMMARY

(See Appendix C for an explanation of acronyms)

A river is any natural stream of water that flows in a channel with defined banks. There are 113 major river system basins in the world. They carry on average over 15% of the world's commerce. "Approximately 80% of the world's population (4.8 billion people) lives within 100 kilometers of the world's major river basins."¹ Control of the river ways is vital to commerce and national security. In the aftermath of the 9/11 atrocities perpetrated against the United States, the US began the Global War on Terrorism (GWOT). The riparian environments are strategically important in support of GWOT. They can be used for shipment of weapons, contraband, and illegal drugs to support terrorist and insurgent operations.

Over the past several years it has become apparent that the US Navy needed a brown water capability to better combat today's threats. "The Chief of Naval Operations Strategic Studies Group 24 recommended expanding the Navy's green and brown water capability to rebalance the force so the United States Navy can better combat today's green and brown water threat."² Addressing the National Defense Industry Association Expeditionary Warfare Conference in October 2005, the Chief of Naval Operations (CNO), Admiral Mike Mullen emphasized the new landward push. "There are great opportunities for the global security environment. Maritime Domain Awareness -- that is where we are really going in respect to operations in green water and brown water as we evolve that over time."³ The CNO followed his comment a few months later when he established the Naval Expeditionary Combat Command in Little Creek, Virginia.

"The U.S. Navy established the Navy Expeditionary Combat Command (NECC) in January 2006 to serve as a single functional command to centrally manage current/future readiness, resources, manning, training and equipping of the Navy's expeditionary forces."⁴ The NECC's mission is to integrate all war fighting requirements for expeditionary combat and combat support elements. In May of 2006 the NECC established Riverine Group One to serve as administrative command over three riverine squadrons. According to Rear Admiral Donald Bullard, NECC's commander,

”we know there are many areas around the world where rivers are the main lines of communication. We, the Navy, need to expand in order to go into that brown water environment, to be able to train and work with our combined allies and neighbors and make those lines of communication secure.”⁵

The focus of the Navy’s riverine group will be on conducting maritime security operations (MSO) and theater security cooperation (TSC) in riparian areas of operations or other suitable areas. This might entail protecting critical infrastructure, securing the area for military operations or commerce, preventing the flow of contraband, enabling power projection operations, joint, bi-lateral or multi-lateral exercises, personnel exchanges, and humanitarian assistance.⁶ MSO entails policing the maritime domain to prevent and/or disrupt terrorism, drug trafficking, piracy, environmental destruction and human trafficking. Conducting exercises with other navies and providing Humanitarian Assistance/Disaster Relief (HADR) typify cooperative TSC operations. The Riverine Force (RF) will be capable of deploying world-wide within 96 hours in support of MSO and TSC missions.

The 2007 Naval Postgraduate School (NPS) Systems Engineering and Analysis (SEA) Integrated Project titled “Riverine Sustainment 2012” was a joint product developed by eight NPS SEA students and 17 National University of Singapore (NUS) Temasek Defense Systems Institute (TDSI) students. The two cohorts combined students from various professional and academic backgrounds to form the Riverine Sustainment Team (RST). The purpose of the RST was to define, analyze, and recommend alternatives for supply, repair, and force protection that increase sustainability of the riverine force in the riparian environment utilizing technologies currently in use or available for use by 2012.” Additionally, a study was conducted into the potential for use of developing commercial technologies which could advance the riverine force communications capacity to handle the multiple types and high volumes of information necessary in modern tactical environments.

Systems engineering is a top-down, problem solving process that captures stakeholders’ needs, analyzes alternatives and advocates a solution. “Systems engineering is a management technology to assist and support policy making, planning,

decision making, and associated resource allocation or action deployment. Systems engineers accomplish this by quantitative and qualitative formulation, analysis, and interpretation of the impacts of action alternatives upon the needs perspectives, the institutional perspectives, and the value perspectives of their clients or customers.”⁷

The RST started with the RF’s operational concept and utilized a combination of the physical and functional architectures to develop the operation architecture. Modeling and simulation enabled the RST to measure physical architecture alternatives that achieved RF sustainment functional objectives. The RST utilized both deterministic and stochastic models for analyzing the riverine sustainment problem. During the analysis models were developed Extend, SIMKIT, MATLAB, Excel and MANA to evaluate the performance and effectiveness of the various alternatives.

The key findings of the functional groups are described as follows:

Supply Group

- Key factors of riverine sustainment supply success are supply ship cycle time, basing alternative, logistics connector survivability, operational availability of the SURC’s and cost. Given the supply ship cycle time, basing alternative, and number of assets used, the RST was able to determine the most effective configuration of connectors.
- Helicopters add very little to the overall performance of the configuration of connectors, but they increase the cost significantly. If the RF operates from a FOB with a supply ship cycle time between 4-7 days, then the most effective connector is the LCU-2000. This is because the LCU-2000 can carry the entire supply load in one run. When the supply ship cycle time increases to 8-9 days, then the LCU-2000 can no longer carry the entire supply load in one run. Instead, the Jim G becomes the most effective connector. This is assuming that the RF would have to procure an LCU-1610 and LCU-2000. If the procurement of the two crafts is not necessary, then the LCU-2000 with an LCU-1610 would be the most cost effective configuration. If only one vessel is used, then the Jim G will allow the maximum supply ship cycle time to maintain a 95% operational availability of SURC’s due to fuel if the supply ship cycle time is not specified.
- If the RF operates from a Nobriza+Barge MOB with a supply ship cycle time between 4-7 days, then the most cost effective connector is the LCU-2000. Similar to the FOB, the Nobriza+Barge requires a seven day supply load that

can fit in the LCU-2000. When the supply ship cycle time increases to 8-9 days, then the LCU-2000 with an LCU-1610 is the most effective configuration. Unlike the FOB, the Nobriza+Barge requires a slightly greater supply load that would require a LCU-2000 and a Jim G to do multiple runs. If only one vessel is used, then the Jim G will allow the maximum supply ship cycle time to maintain a 95% operational availability of SURC's due to fuel if the supply ship cycle time is not specified.

- If the RF operates from the RCSS, Endurance, or Sri Inderapura MOB with a supply ship cycle time between 4-7 days, then the most effective configuration of connectors is a Jim G with an LCU-1610. The increase in supply load compared to the other basing alternatives requires multiple runs when a single Jim G or two LCU-1610's are used. When a Jim G and an LCU-1610 are combined, they can re-supply the MOB in one run. When the ship cycle time increases to 8-9 days, then two Jim G's is the most effective configuration. If only one vessel is used, then the Jim G will allow the maximum supply ship cycle time to maintain a 95% operational availability of SURC's due to fuel if the supply ship cycle time is not specified.
- For a single connector, the Jim G supported the best supply ship cycle time.

Repair Group

- Increasing personnel, maintenance bays, or SURC did not have a significant effect on improving operational availability in the repair model, and with this in mind it is recommended that the status quo remain in place. However, when considering the RST scenario constraint of maintaining at least 9 mission ready SURC's at all times, the alternative of increasing both personnel and maintenance bays was cheaper than procuring additional SURC's. Also, the model indicated that MSRT was the biggest factor that affected SURC operational availability. MSRT's exceeding 24-hours drove operational availabilities below 80%. Given a logistically barren environment as presented in the RST scenario, it is vital that an exhaustive PUK is developed for the RF. This PUK must not only contain high failure rate items, but also items that fail at moderate rates.
- The model developed by the Repair Group can serve as a planning tool for a wide variety of future riverine warfare operations. As key parametric changes can be easily implemented within the model, such as environmental concerns, Commander's discretion, medical problems, and so forth, the Repair Group's model has established a foundation upon which such studies can be made. Since every alternative, including the status quo, is very sensitive to MSRT,

the repair model may serve as a tool for repair re-supply planning and evaluation of logistics alternatives that involve faster connectors such as airlift.

Force Protection Group

- Current mortar defenses proposed by the RF are insufficient. The analysis conducted in this study was with the aide of a host nation providing security beyond the FOB's perimeters out to the expected mortar range. Even though the best alternative improved on the baseline by severely decreasing the number of mortar rounds that hit the base, the modeling showed that three mortar rounds still struck the base. This means that even with the mortar defenses proposed in this study, the FOB could expect to be hit by mortar rounds each time they are attacked. If the RF is based at the a FOB ashore, then the host nation needs to provide robust perimeter defense. For the decision maker deciding which basing alternative to consider, this is a major consideration because a MOB can move and prove less susceptible to mortar fire, especially with as wide a river as the Kampar.
- The analysis also revealed that the ROSAMs were an excellent resource for force protection in two different scenarios. The ROSAMs provide a reduction in manpower, which decreased the RF footprint and also promoted greater RF survivability when the FOB was attacked.
- The MOB boat attack scenarios revealed that the Nobriza and Barge were the most cost effective means to defend the RF when they were operating from a MOB. The Nobriza provided excellent firepower without added exposure of personnel, which was discovered to be a draw back for a patrol boat.
- For perimeter defenses, IR illuminators coupled with the NVG's are very valuable assets. The RF should also consider using acquiring RDFW units for the creation of bunkers.

Communications Technology

- Communications equipment in use by riverine forces requires modernization and increased capacity.

- Worldwide Interoperability for Microwave Access (WiMAX) technology showed the greatest potential for addressing riverine force communications needs utilizing commercially available equipment currently in use in industry.

Because of the short duration of this study there were numerous areas that were not examined. Chapter 10 has a complete list of areas for further study.

¹ Naval Expeditionary Combat Command, *U. S. Navy Riverine Group, Concept of Operations* (Little Creek, VA: GPO, 2006), 22.

² James Beaver and others, “Systems Analysis of Alternative Architectures for Riverine Warfare in 2010” (MS diss., Naval Postgraduate School, 2006), 19.

³ Chief of Naval Operations remarks as delivered at the National Defense Industry Association Expeditionary Warfare Conference, Panama City, Fla., 26 Oct. 2005, <http://www.navy.mil/navydata/leadership/mist.asp?x=S>.

⁴ Naval Expeditionary Combat Command, “About Us,” *Naval Expeditionary Combat Command*, <http://www.necc.navy.mil/>

⁵ Navy Newsstand. “Navy Establishes First Riverine Group”, *Navy.mil*, http://www.navy.mil/search/display.asp?story_id=23854.

⁶ Naval Expeditionary Combat Command, *U. S. Navy Riverine Group, Concept of Operations*, (Little Creek, VA: GPO, 2006), 7.

⁷ Andrew P. Sage and James E. Armstrong Jr., *Introduction to Systems Engineering* (New York: John Wiley & Sons, 2000), 8-9.

1. INTRODUCTION

1.1 BACKGROUND

A river is any natural stream of water that flows in a channel with defined banks. There are 113 major river system basins in the world. They carry on average over 15% of the world's commerce. "Approximately 80% of the world's population (4.8 billion people) lives within 100 kilometers of the world's major river basins."⁸ Control of the river ways is vital to commerce and national security. In the aftermath of the 9/11 atrocities perpetrated against the United States, the U.S. began the Global War on Terrorism (GWOT). The riparian environments are strategically important in support of GWOT. They can be used for shipment of weapons, contraband, and illegal drugs to support terrorist and insurgent operations.

Over the past several years it has become apparent that the U.S. Navy needed to develop a brown water capability to better combat today's threats. "The Chief of Naval Operations Strategic Studies Group 24 recommended expanding the Navy's green and brown water capability to rebalance the force so the at the United States Navy can better combat today's green and brown water threat."⁹ Addressing the National Defense Industry Association Expeditionary Warfare Conference in October 2005, the Chief of Naval Operations (CNO), Admiral Mike Mullen emphasized the new landward push. "There are great opportunities for the global security environment. Maritime Domain Awareness -- that is where we are really going in respect to operations in green water and brown water as we evolve that over time."¹⁰ The CNO followed his comment a few months later when he established the Naval Expeditionary Combat Command in Little Creek, Virginia.

"The U.S. Navy established the Navy Expeditionary Combat Command (NECC) in January 2006 to serve as a single functional command to centrally manage current/future readiness, resources, manning, training and equipping of the Navy's expeditionary forces."¹¹ The NECC's mission is to integrate all war fighting requirements for expeditionary combat and combat support elements. In May of 2006 the NECC established Riverine Group One to serve as administrative command over three riverine

squadrons. According to Rear Admiral Donald Bullard, NECC's commander, "we know there are many areas around the world where rivers are the main lines of communication. We, the Navy, need to expand in order to go into that brown water environment, to be able to train and work with our combined allies and neighbors and make those lines of communication secure."¹²

The focus of the Navy's Riverine Group will be on conducting maritime security operations (MSO) and theater security cooperation (TSC) in riparian areas of operations or other suitable regions. This may entail protecting critical infrastructure, securing the area for military operations or commerce, preventing the flow of contraband, enabling power projection operations, joint, bi-lateral or multi-lateral exercises, personnel exchanges, and humanitarian assistance.¹³ MSO entails policing the maritime domain to prevent and/or disrupt terrorism, drug trafficking, piracy, environmental destruction and human trafficking. Conducting exercises with other navies and providing Humanitarian Assistance/Disaster Relief (HADR) typify cooperative TSC operations. The Riverine Force (RF) will be capable of deploying world-wide within 96 hours in support of MSO and TSC missions.

The Riverine Sustainment Team (RST) examined RF Logistics, Force Protection (FP), and Repair in support of MSO in a riparian environment. RST analyzed current RF baselines, technologies, force structures and assets and compared them with feasible alternative that could be fielded by 2012. The study utilized agent-based and queuing models to support alternative analysis, feasibility screening, and recommendations.

1.1.1 Countering the New Threat

During the Cold War Era the U.S. Navy built an impressive blue water war-fighting capability to counter Soviet Union ships, aircraft, and submarines. In the late 1980's, the Soviet Union and its military power dissolved after sweeping political change. The U.S. Navy no longer had a potential adversary that could challenge them on the high seas. "When the United States was attacked on September 11, 2001, its people began to fully realize that it had entered into a new type of warfare, not against a

conventional army from a single hostile state, but rather against an unconventional enemy operating world wide in states that failed or were teetering on the brink of collapse.”¹⁴

The U.S. military and especially its Navy were ill-equipped to be effectively utilized in the GWOT. The previous two CNO’s made positive strides in moving the Navy from the deep blue water into the littorals. In his speech to students and faculty at the Naval War College in August 2005, the CNO, Admiral Mike Mullen reiterated the landward objective.

We cannot sit out in the deep blue, waiting for the enemy to come to us. He will not. We must go to him. We need a green-water capability and a brown-water capability. I want the ability to go close in and stay there. I believe our Navy is missing a great opportunity to influence events by not having a riverine force. We’re going to have one.¹⁵

In March 2007 that push continued as the NECC deployed Riverine Squadron One to conduct security operations at the Haditha Dam on the Euphrates River in Iraq. This event marked the first U.S. Navy Riverine deployment since the Vietnam Conflict.

1.1.2 Sustainment Definition

Sustainment is the provision of logistics and personnel services necessary to maintain and prolong operations until mission accomplishment. The focus of sustainment in joint operations is to provide the Joint Force Commander (JFC) with the means to enable freedom of action and endurance and extend operational reach. Effective sustainment determines the depth to which the joint force can conduct decisive operations; allowing the JFC to seize, retain and exploit the initiative.¹⁶

The RST focused on how best to support a Riverine Squadron in a logistically barren environment. Logistically barren environment is defined as an operating area that is not serviced by an adequate airport or port facility. These areas are typical unimproved areas with dense vegetation making them unsuitable for fixed-wing operations. The RST decomposed sustainment into three distinct functional areas: supply, repair, and force protection.

The Joint Chiefs of Staff (JCS) describe supply as “the procurement, distribution, maintenance while in storage, and salvage of supplies, including the determination of

kind and quantity of supplies”¹⁷ The U.S. military relies heavily on an extensive supply chain network to sustain its unit’s world wide. Continental United States (CONUS) ports, strategic lift, forward logistic sites (FLS), intra-theater support, and shuttle lift are primary components of the U.S. military logistics system. This collection of ports, connectors and transfers are responsible for moving a vast array of supplies anywhere in the world.

The supplies that are transported by strategic lift and intra-theater shuttles can carry a multitude of products for the combatant commander. Those supplies are separated into ten different classes which are illustrated in Table 1.

CLASSES		SUBCLASSES
Class I - Subsistence		A - Nonperishable C - Combat Rations R - Refrigerated S - Other Nonrefrigerated W - Water
Class II - Clothing, Individual Equipment, Tools, Admin. Supplies		A - Air B - Ground Support Materiel T - Industrial Supplies E - General Supplies G - Electronics M - Weapons F - Clothing
Class III - Petroleum, Oils, Lubricants		A - POL for Aircraft W - POL for Surface Vehicles P - Packaged POL
Class IV - Construction Materials		A - Construction B - Barrier
Class V - Ammunition		A - Air Delivery W - Ground
Class VI - Personal Demand Items		
Class VII - Major End Items: Racks, Pylons, Tracked Vehicles, Etc.		A - Air B - Ground Support Materiel D - Admin. Vehicles J - Racks, Adaptors, Pylons K - Tactical Vehicles G - Electronics L - Missiles M - Weapons N - Special Weapons X - Aircraft Engines
Class VIII - Medical Materials		A - Medical Materiel B - Blood / Fluids
Class IX - Repair Parts		A - Air B - Ground Support Materiel D - Admin. Vehicles G - Electronics K - Tactical Vehicles L - Missiles M - Weapons N - Special Weapons X - Aircraft Engines
Class X - Material For Nonmilitary Programs		

Table 1. Classes of Supplies¹⁸

Classes 1 (subsistence), 3 (petroleum, oils, and lubricants), 5 (ammunition) comprised a large majority of the overall supply demand. The RST concentrated on the transfer of these classes and class 9 (repair parts) within the area of operation (AO) to sustain the RF.

Another pivotal function of RF sustainment is repair. Joint Publication 1-02 defines repair as “the restoration of an item to serviceable condition through correction of a specific failure of unserviceable condition.”¹⁹ Proper preventive and corrective maintenance (repair) is vital to operational readiness. Preventive maintenance includes routine inspections, testing, and service to keep equipment in the highest states of readiness. When non-routine malfunctions occur, corrective maintenance must be conducted to return the equipment to good working order. The RST looked primarily at the repair of the RF’s 12 small unit riverine craft (SURC), and 65 pieces of rolling gear. The goal of the study was to find the optimal number of maintainers with the right mix of skill-sets to deliver the highest availability rates.

The SURC was introduced in 2004 to replace the aging Riverine Assault Craft (RAC) and rigid raiding craft (RRC). It provides “mobility, speed, endurance, firepower, payload, survivability, and command and control capabilities to support sustained operations in a riparian environment.”²⁰ With its twin 440-horsepower engines, the SURC can accelerate from zero to 25 knots in 15 seconds and achieve a top speed of 40 knots. This boat is designed to operate in shallow river environments (2 foot draft), supports crew-served weapon systems from three gun mounts, and transports boarding teams of ten or less.

The RF deploys with 65 pieces of rolling-gear. Rolling-gear consists of SURC trailers, medium tactical vehicle replacements (MTVR’s), high mobility multi-purpose wheeled vehicles (HMMWV’s), 5-ton wreckers and various forklifts. This support gear is vital to deploying and sustaining the RF.

The third critical sustainment function is force protection.

Force protection includes preventive measures taken to mitigate hostile actions against DOD personnel, resources, facilities, and critical information. These actions conserve the force’s fighting potential so it can

be applied at the decisive time and place and incorporates the integrated and synchronized offensive and defensive measures to enable the effective employment of the joint force while degrading opportunities for the adversary. Force protection is achieved through the tailored selection and application of multilayered active and passive measures, with the air, land, maritime, and space domains and the information environment across the range of military operations with an acceptable level of risk. Intelligence sources provide information regarding an adversary's capabilities against personnel and resources, as well as providing timely information to decision makers regarding force protection considerations.²¹

The RST examined force protection measures for the forward operating base (FOB) in the riparian environment. The FOB is an ashore, support base that requires a secured perimeter and actionable intelligence for force protection. The overarching goal of the force protection system (FPS) was to deter, predict, and deny the enemy. Deter employs a system of warnings and show of force to ward off enemy and non-combatants alike. Predict utilizes the RF's intelligence resources (unmanned aerial vehicles, non-organic and organic intelligence systems) to observe and forecast the enemy's movements, intentions and actions. And deny combines the RF base's self-defense capabilities to engage hostile elements and block their entry. Any FPS would be useless without effective communication.

“Fighting with a large army under your command is nowise different from fighting with a small one; it is merely a question of instituting signs and signals.”²² Command, Control and Communications (C3) are vital to any military operations. “Command and control is the exercise of authority and direction by a properly designated commander over assigned and attached forces in the accomplishment of the mission.”²³

No single activity in military operations is more important than C2. Alone C2 will not destroy a single adversary target or affect a single emergency re-supply. Yet, none of these essential joint force activities, or any others, would be possible without effective C2. A superior communications system helps commanders to maintain the unity of effort to their forces' capabilities at the critical times and places to win.²⁴

The RST communications effort focuses on enabling this connectivity in a coalition environment that includes not only joint forces, but also governmental, non-governmental, and foreign military units.

1.1.3 Historical Analysis

U.S. Navy Riverine Warfare is definitely not a term uttered or considered in many years. However, with the emerging Global War on Terrorism (GWOT) and the Navy's vision of effectively increasing its capabilities to combat this new threat, the U.S. Navy has established the Naval Expeditionary Combat Command (NECC). This new command will essentially fill the capability gap in this new effort by increasing the Navy's power projection capability.

Riverine Warfare has always played a major role in every major conflict or campaign throughout the U.S. Military's long and distinguished history. This section will not detail the history of the U.S. Riverine Forces and campaigns. However, this section will summarize lessons learned from these past historical events. An important part of history is being able to draw conclusion from it and applying the lessons learned in order to make more informed decisions and not repeat the same mistakes over again.

The U.S. military has historically maintained an "on again, off again" relationship with riverine forces. During every major conflict throughout U.S. history there has arisen the need for a riverine capability. This riverine capability was developed and deployed to meet the current needs and threats of the period. However, once the conflicts were over, the riverine forces were disbanded. There are several reasons for this occurrence though time. Changes in political policies, budgetary constraints, and the primary focus of the U.S. Navy have all played major roles in the demise of a long standing U.S. Riverine Force and capability.

From the Revolutionary War through the Vietnam Conflict, the Riverine force was developed and deployed within a year's time.²⁵ This war fighting capability gap was hastily fielded with ad hoc vessels and personnel to meet the requirements of those periods. Tactics, training, craft concepts, and personnel experience had to be developed from scratch in order to field these forces.

In every U.S. conflict, the U.S. riverine forces were developed with a large variety of riverine craft. Each craft played various and vital roles.

Operations on or projected from inland waters have come to be called "riverine warfare." Here fighting craft, tailored as necessary to the environment, bring combined operations the unique advantages of power based afloat--greater mobility, ease of concentration, swift shift of objectives, speed, flexibility, versatility, and surprise. If water permits, large ships like cruisers and destroyers blast aside opposition. For shallower depths many types of small warcraft develop to fit the need. We have seen this occur throughout United States history since riverine operations on small or large scale have entered into most of the limited or world wars that seem our fate²⁶

Attempts have been made to develop a single craft for riverine use, but all have fallen short of their objectives. This is probably due to the large numbers of various missions and roles that a riverine force has to perform as well as the different operating environments these craft are subjected to.

In summary, the U.S. needs to develop a permanent riverine war fighting capability and develop policies to ensure its longevity. This riverine capability has proven itself again and again and by dismantling this force as soon as a major conflict is over is detrimental because the lessons learned, tactics, and personnel experiences are all lost in the sands of time. An Inland Water Force must be thoroughly developed using proven engineering techniques and analysis in order to be effective, which takes time to do effectively. Fielding ad hoc forces in a short period of time is essentially placing personnel in a heightened risk of danger due to inadequate training and ineffective, unproven equipment. Using the systems engineering approach with detailed analysis will also prove that no one riverine craft is suited to effectively fill all the capabilities required for the numerous missions and environments that these craft will be subjected to. An informed, decisive effort must be put forth in order to properly develop, train, and deploy these forces that can effectively and safely complete the required missions.

1.2 PURPOSE

This collaborative study will serve as Systems Engineering and Analysis (SEA) Cohort 11 Integrated Project. Biannually the Wayne E. Meyer Institute of Systems Engineering sponsors this campus-wide effort at the Naval Postgraduate School. On

December 12, 2006, the project team received the SEA-11 Capstone Project Objectives Memorandum from the institute with the following guidance:

Collaborate with the Naval Expeditionary Combat Command (NECC) to design a system of systems for performing emerging Navy missions associated with coalition operations in littoral and riverine environments. Potential Focus Areas: capability gaps and potential options for enabling future multi-national operations; joint, interagency, and intergovernmental command and control and information exchange; and CONOPS for joint, interagency, and international operations.²⁷

The study was directed to assume a cooperative, international, environment, which echoed the U. S. Navy's "1,000 Ship Navy" concept.

All maritime nations are affected by these challenges and all must bear a hand in taken them on. There is no one nation that can provide a solution alone. A global maritime partnership is required that unites maritime forces, port operators, commercial shippers, and international, governmental and nongovernmental agencies to address mutual concerns. The concept is not actually about having 1,000 international ships at sea. Rather, it is more about capabilities, such as speed, agility and adaptability. Membership in this navy is purely voluntary and has no legal or encumbering ties. It is a free-form, self-organizing network of maritime partners –good neighbors interested in using the power of the sea to unite, rather than divide.²⁸

This initiative challenged the Navy to leverage its current partnerships and forge new ones to create a more secure maritime domain.

SEA 11 was tasked to fully integrate international students from the Temasek Defence Systems Institute (TDSI) into the study.

TDSI is a strategic alliance between two eminent institutions: the U.S. Naval Postgraduate School (NPS) and the National University of Singapore (NUS).TDSI was established on 11 July 2001 to provide the platform to bring together military staff and defence technologists in an education and research environment. TDSI aims to produce graduates who understand the complexities of a military force, so as to be able to create maximum leverage by the integration of operations and technology.²⁹

The TDSI students came from several different academic backgrounds that included Operations Research, Weapon Systems, Communications, Information Assurance, and Modeling, Virtual Environments, and Simulation (MOVES). To leverage

the diverse talents of both groups, the SEA 11 Cohort and TDSI students formed the RST and developed four integrated project teams (IPT's): supply, repair, force protection, and communications. The four IPT's addressed the critical operational issues and delivered the system engineering products within their functional area.

The newly formed RST was given further instruction to seek out additional expertise within NPS.

You will be expected to identify and integrate students and faculty from across the campus to participate in your projects. This participation could include students who would join your groups, students doing related individual thesis topics, and faculty inside or outside NPS who have expertise related to your projects. It will be your responsibility to integrate the efforts of outside participants in your projects.³⁰

In addition to the TDSI students and faculty, the project team collaborated with the Coalition Operating Area Surveillance and Targeting System (COASTS) and Tactical Network Topography (TNT) programs to gain additional insights. The COASTS and TNT programs are bottom-up efforts which seek to provide timely situational awareness using commercial off-the-shelf wireless networking technologies.

1.3 SCOPE

The RST consisted of eight students from NPS and 17 from TDSI. All NPS personnel were from the systems engineering and analysis curriculum, but their operational experiences were diverse: three U.S. Naval Surface Warfare Officers (one with special boat training), a U.S. Army Artillery Officer, a U.S. Naval Submariner (former U.S. Marine), a U.S. Naval Flight Officer, and two recent graduates from the Naval Academy. The SEA-11 Cohort began work on the campus-wide project in November 2006, with a completion date of June 2007. In mid-November, the SEA-11 and TDSI students shared their project ideas by way of video teleconference. The final project tasking from the Wayne E. Meyer Institute was received in mid-December.

In January 2007, the TDSI students arrived at NPS to begin their one year of instruction. TDSI students were enrolled in several different curriculums at NPS: operations research (OR), information assurance (IA), communications, weapon systems,

sensor systems, and MOVES. The TDSI student hailed from several different backgrounds: four defense contractors from Singapore Technologies, three Singaporean government employees from the Defence Science and Technology Agency, one scientist from the Defence Science Organisation National Laboratory, six Singaporean Army Officers, a Singaporean Naval Officer, a U.S. Naval Submariner, and an Israeli Army Officer.

The RST gathered and organized information from students, professors, experts, and stakeholders from NPS, Massachusetts Institute of Technology (MIT), Naval Expeditionary Combat Command (NECC), Naval Special Warfare Group Four, Naval Special Warfare Group One, Logistics Support Group One, Naval Small Craft Instruction and Technical Training School (NAVSCIATTS), Special Boat Team Twenty-Two, and Naval Sea Systems Command's (NAVSEA) Operations Logistics Group.

The guidance from the Meyer's Institute to the RST was to develop a system that addresses Maritime Security Operations (MSO) in the riparian and littoral environment (Appendix B). Given the CNO's recent comments, "there are great opportunities for the global security environment. Maritime Domain Awareness -- that is where we are really going in respect to operations in green water and brown water as we evolve that over time.³¹", the RST decided to focus on the landward areas that are referred to as brown water. Within the brown water environment the RF has been tasked with the MSO mission.

MSO is the principle mission for the riverine group. MSO help maintain security on the seas, or in this case the rivers and inland waterways that the riverine squadrons will expected to operate. They are one of the most important Navy efforts used to combat sea-based terrorism and other illegal activities, such as transporting components of weapons of mass destruction, hijacking, piracy, and slavery, also known as human trafficking. In this case maritime security operations would be primarily involved in the rivers, lakes, harbors and deltas within the Joint Force Maritime Component Commander's (JFMCC) battlespace. To conduct these operations, the riverine group will be involved in patrol and interdiction, anti-piracy, and Maritime Interdiction Operations/Extended Maritime Interdiction Operations (MIO/EMIO) with their area of operations.³²

Once the problem was refined to MSO in the riverine environment, further bounding was required to support the project deadlines.

To bound a project means to understand the limitations associated with the project, the changes that can be made to achieve desired objectives, and the important quantities that are likely to change as a result of the project. In systems terms, this means identifying the constraints, parameters, and variables for the project. Constraints are the limits that must be observed for the project. Constraints include realistic considerations related to things such as money, time, people, organizations, and society. For example, most projects have budget time deadlines, and environmental impact constraints.³³

The RST initially bounded the problem to the area of operations (AO) which simplified the logistics considerations considerably. Both the movement of the RF and supplies to sustain the RF to the AO were intentional left out to enable the timely delivery of this report.

Based on functional areas the RST was divided into four integrated project teams (IPT's): Supply; Repair; Communications, and Force Protection. Each group had one or two system engineering students and several TDSI students. To the best extent possible, the TDSI students were placed in IPT's that would support their individual curriculum tracks. This organizational IPT structure is illustrated in Figure 1.

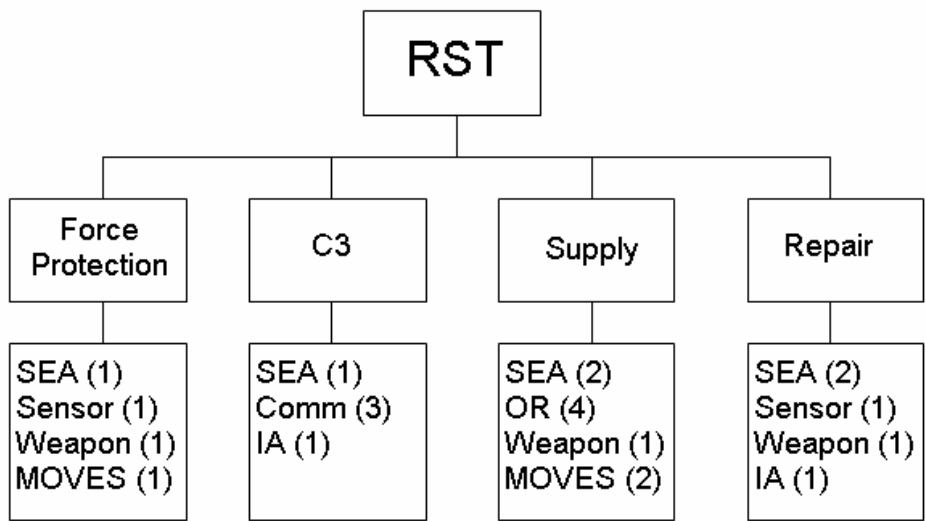

Figure 1. RST Breakdown

The Force Protection IPT was tasked with defining the FOB footprint and designing alternative architectures for FOB force protection. . Developing a coalition command and control network was the responsibility of the Communications' IPT. Due to the overall vision of this project focusing on the sustainment of the RF, the Communications aspect did not develop along this functional area. However, Communications of the RF is developed and discussed in Appendix E. The Repair IPT focused on the man-hour requirement and critical skills need for the upkeep on the forces' riverine craft and support equipment. And comparing several throughput systems to support the FOB and MOB physical architectures was the goal of the Supply IPT.

1.4 REGIONAL CHARACTERISTICS

1.4.1 Economy

Indonesia, a vast polyglot nation, has struggled to overcome the Asian financial crisis, and still grapples with persistent poverty and unemployment, inadequate infrastructure, endemic corruption, a fragile banking sector, a poor investment climate, and unequal resource distribution among regions. The country continues the slow work of rebuilding from the devastating December 2004 tsunami and from an earthquake in central Java in May 2006 that caused over \$3 billion in damage and losses. Declining oil production and lack of new exploration investment turned Indonesia into a net oil importer in 2004. The cost of subsidizing domestic fuel placed increasing strain on the budget in 2005, and combined with indecisive monetary policy, contributed to a run on the currency in August, prompting the government to enact a 126% average fuel price hike in October. The resulting inflation and interest rate hikes dampened growth through mid-2006, while large increases in rice prices pushed millions more people under the national poverty line. Economic reformers introduced three policy packages in 2006 to improve the investment climate, infrastructure, and the financial sector, but translating them into reality has not been easy. Keys to future growth remain internal reform, building up the confidence of international and domestic investors, and strong global economic growth. Significant progress has been made in rebuilding Aceh after the devastating December 2004 tsunami, and the province now shows more economic activity than before the disaster. Unfortunately, Indonesia suffered new disasters in 2006 and early 2007 including: a major earthquake near Yogyakarta, an industrial accident in Sidoarjo, East Java that created a "mud volcano," a tsunami in South Java, and major flooding in Jakarta, all of which caused additional damages in

the billions of dollars. Donors are assisting Indonesia with its disaster mitigation and early warning efforts.³⁴

1.4.2 Geography

Indonesia is the largest archipelago in the world. It consists of five major islands and about 30 smaller groups. The figure for the total number of islands is 17,508 according to the Indonesian Naval Hydro-Oceanographic office. The archipelago is on a crossroad between two oceans, the Pacific and the Indian, and bridges two continents, Asia and Australia. This strategic position has always influenced the cultural, social, political, and economic life of the country. The five main islands are: Sumatra, which is about 473,606 sq km in size; the most fertile and densely populated islands, Java/Madura, 132,107 sq km; Kalimantan, which comprises two-thirds of the island of Borneo and measures 539,460 sq km; Sulawesi, 189,216 sq km; and Irian Jaya, 421,981 sq km, which is part of the world's second largest island, New Guinea. Indonesia's other islands are smaller in size. The archipelago is divided into three groups. The islands of Java, Sumatra, and Kalimantan, and the small islands in-between, lie on the Sunda Shelf which begin on the coasts of Malaysia and Indo China, where the sea depth does not exceed 700 feet. Irian Jaya which is part of the island of New Guinea, and the Aru Islands lie on the Sahul Shelf, which stretches north wards from the Australia coast. Here the sea depth is similar to that of the Sunda Shelf. The land area is generally covered by thick tropical rain forests, where fertile soils are continuously replenished by volcanic eruptions like those on the island of Java. The country is predominantly mountainous with some 400 volcanoes of which 100 are active. Mountains higher than 9000 feet are found on the islands of Sumatra (Mt. Leuser and Mt. Kerinci); Java (Mt Gede; Mt. Tangkubanperahu, Mt. Ciremai, Mt. Kawi, Mt. Kelud, Mt. Semeru and Mt. Raung), Sulawesi (Mt. Lompobatang and Mt. Rantekombala), Bali (Mt. Batur and Mt. Agung), Lombok (Mt. Rinjani) and Sumbawa (Mt. Tambora). The highest mountain is the perpetually snow-capped Mandala Top (15,300 feet) in the Jaya Wijaya mountain range of Irian Jaya. Many rivers flow throughout the country. They serve as useful transportation routes on certain islands, for example, the Musi, Batanghari, Indragiri and Kampar rivers in Sumatra; the Kapuas, Barito, Mahakam and Rejang rivers in Kalimantan; and the Memberamo and Digul rivers in Irian Jaya. On Java rivers are important for irrigation purposes, i.e., the Bengawan Solo, Citarum and Brantas rivers.³⁵

Due to the large number of islands, Indonesia has about 54,716 km (about 33,999 mi) of coastline, much more than most countries. The country claims all waters surrounding its islands to 12 nautical miles (22 km/14 mi) from the coastline. Indonesia's exclusive economic zone, an area of

the ocean in which the country controls fishing and other rights, extends 200 nautical miles (370 km/230 mi) from its shore.³⁶

1.4.3 Climate and Weather

The climate and weather of Indonesia is characterized by two tropical seasons, which vary with the equatorial air circulation and the meridian air circulation. The displacement of the latter follows the north-south movement of the sun and its relative position from the earth, in particular from the continents of Asia and Australia, at certain periods of the year. These factors contribute to the displacement and intensity of the Inter-Tropical Convergence Zone (ITCZ) which is an equatorial trough of low pressure that produces rain. Thus, the west and east monsoons, or the rainy and dry seasons, are a prevalent feature of the tropical climate. The climate changes every six months. The dry season (June to September) is influenced by the Australian continental air masses; while the rainy season (December to March) is the result of the Asian and Pacific Ocean air masses. The air contains vapor which precipitates and produces rain in the country. Tropical areas have rains almost the whole year through. However, the climate of Central Maluku is an exception. The rainy season is from June to September and the dry season from December to March. The transitional periods between the two seasons are April to May and October to November. Due to the large number of islands and mountains in the country, average coastal plain temperatures are 28 degrees Centigrade with an average relative humidity between 70% and 90%.³⁷

Average rainfall in the lowlands varies from 1,780 to 3,175 mm (70 to 125 in) per year, and in some mountain regions rainfall reaches 6,100 mm (240 in) per year. The regions with the highest rainfall include the mountainous western coast of Sumatra and the upland areas of western Java, Kalimantan, Sulawesi, and Papua.³⁸

1.5 PHYSICAL BASING ALTERNATIVES

Riverine forces often operate in remote locations and may not be collocated with existing support facilities. A Riverine Support Base should be established to provide operational and logistic support to the riverine forces. Base sites should balance the ability to support riverine forces with force protection concerns while maximizing accessibility to land, water, and air re-supply and communications lines. The Riverine Support Base functions must be tailored to the mission and expected deployment length.³⁹

The RST envisioned three RF support base options: forward operating base (FOB), mobile operating base (MOB) and global fleet station (GFS).

“The riverine support base functions must be tailored to the mission and expected deployment length. Support functions include:

- Operational Support. C4I and operational planning and evaluation support are essential. Communications with all attached joint forces special attention
- Medical Support. Emergency medical services must be provided. Medical supply stocks, inventory control, and shelf life require special consideration.
- Logistics. Supplies flow to the riverine support base for further distribution to the supported units. Supplies include ordinance, fuel, food repair parts, and medical.
- Helicopter Support. The employment of forces to remote and disperse areas makes it difficult to ensure lines of supply and communications. To provide for emergency supply, MEDIVAC, and reinforcement support, a helicopter unit should be provided to the base.
- Maintenance. Facilities must be provided for weapons, ordinance, and riverine craft maintenance. The scope of the maintenance support provided will depend on the expected combat damage along mission tempo and duration. Contingency stocking and ready for issue spares.
- Administration. The riverine operating environment and the limited clerical manpower make conducting administrative tasks difficult for operating forces. Administrative task should be accomplished by support base personnel and, where possible, maintain service, pay, medical, and dental records.
- Salvage. The base or other supporting units can provide salvage support.⁴⁰

In addition, the support base maintained storage for the RF's POL, water, ammunition, and food stores. Finally, the support base provided force adequate protection and hotel services for the RF.

1.5.1 Forward Operating Base (FOB)

For the purpose of this study the FOB was a support base that is located ashore along the river. This support base contains space for command and control, intelligence, supply, warehousing, storage, docking, maintenance, administration, berthing, dining, shower and head facilities and hotel services. “Ideally the base should be accessible by air, road, and water in order to facilitate rapid and reliable lines of communication.”⁴¹ The FOB had an area that was cleared out to facilitate helicopters and unmanned aerial vehicle (UAV) operations. Also, a security perimeter with guard towers and fence lines was established to support force protection measures. On the river adjoining the base, netting and other force protection measures were implemented to impede hostiles. The riverbank’s ground composition is firm enough to support the launching and landing of patrol craft and logistic connectors. The FOB acts as the ashore mission and logistics center hub for the RF. Figure 2 depicts a FOB in Iraq.



Figure 2. FOB in Iraq⁴²

1.5.2 Mobile Operating Base (MOB)

The MOB has all the capabilities of the FOB, but it is afloat on the river. Unlike the GFS that operates in permissive environments in international waters, the MOB operates in a non-permissive environment. The MOB heavy armor protects against small

arms and crew-served weapons. In addition to the heavy armor, the FOB has a robust direct fire capability to defeat level one and two ambushes. Figure 3 is the Colombian built MOB, the Nobriza.



Figure 3. Colombian MOB, Nobriza⁴³

1.5.3 Global Fleet Station (GFS)

The CNO is currently developing a concept known as the Global Fleet Station. GFS addresses the steady-state forward presence basing requirement critical to shaping and stability operations that enable persistent interaction with foreign navies and populations. A GFS is a self-sustain home base from which to conduct regional shaping and deterrence operations. It is a base from which tailored, adaptive force packages can be launched in response to natural disasters and actionable intelligence. It affords a small force the ability to engage terrorist or terrorist networks. A GFS is envisioned to have the ability to sustain and employ riverine units throughout a region in support of phase 0 operations or to conduct direct support of GWOT (e.g., surveillance, MIO, and combat insertion)⁴⁴

For the Riverine Sustainment study the GFS would operate in a permissive environment approximately 20 miles from the river mouth. Figure 4 is the San Antonio Class (LPD-17), an alternative GFS for the RF.



Figure 4. The San Antonio Class (LPD-17)⁴⁵

1.6 METHODOLOGY

The methodology section elaborates on the process the RST used to conduct its riverine sustainment analysis.

Methodology is an open set of procedures for problem solving. Consequently, a methodology involves a set of methods, a set of activities, and a set of relations between the methods and the activities. Generally, these include a variety of qualitative and quantitative approaches from a number of disciplines that enable formulation, analysis, and interpretation of the phased efforts that re associated with the definition, development, and deployment of both an appropriate process and the product the results from use of this process. Associated with a methodology is a structured framework into which particular methods are associated for the solution of a specific issue.⁴⁶

1.6.1 System Engineering

Systems engineering is a top-down, problem solving process that captures stakeholders' needs, analyzes alternatives and advocates a solution.

Systems engineering is a management technology to assist and support policy making, planning, decision making, and associated resource allocation or action deployment. Systems engineers accomplish this by quantitative and qualitative formulation, analysis, and interpretation of the impacts of action alternatives upon the needs perspectives, the institutional perspectives, and the value perspectives of their clients or customers.⁴⁷

System Engineering is not a new concept; it has been around since the early 1900's.

The term systems engineering dates back to Bell Telephone Laboratories in the early 1940's. The RAND Corporation was founded in 1946 by the United States Air Force and created systems analysis, which is certainly an important part of systems engineering. The Department of Defense entered the world of systems engineering in the late 1940's with the initial development of missiles and missile-defense systems. The first attempt to teach systems engineering as we know it today came in 1950 at MIT.⁴⁸

Today, as projects become more complex and the margin of error shrinks, proper systems engineering is increasingly important.

The systems engineering process as an organized approach to creativity. It is not a pointless and unstructured free-for-all, nor is it a strict regimen for formulation, analysis and interpretations of large issues associated with the definition, development, and deployment of systems. Often, one of the hardest points for many systems engineering students to understand is that, for most systems engineering problems, there is no single solution, and often no single best solution. There are alternatives, some of which are better than others from some perspectives. The student of systems engineering should not look forward to problems that are well-defined and that can be solved simply by finding the right tool.⁴⁹

According to Sage and Armstrong there are “three fundamental steps for a systems engineering activity:

- Issue formulation
- Issue analysis
- Issue interpretation

These are each conducted at each of the life-cycle phases that have been chosen for the definition, development, and deployment efforts that lead to the engineering of a system. Regardless of the way in which the systems engineering life-cycle process is characterized and regardless of the type of product or system or service that is being designed, all characteristics of the phases of the systems engineering life cycles will necessarily involve:

- Formulation of the Problem – in which the needs and objectives of a client group are identified, and potentially acceptable design alternatives, or options, are identified or generated.

- Analysis of the Alternatives – in which the impacts of the identified design options are identified and evaluated.
- Interpretation and Selection – in which the options, or alternative courses of action, are compared by means of a n evaluation of the impacts of the alternatives and how these are valued by the client group. The needs and objectives of the client group are necessarily used as a basis for evaluation. The most acceptable alternative is selected for implementation or further study in a subsequent phase of systems engineering.

The RST model of the steps of the logic structure of the systems process, shown in Figure 5, is based upon this conceptualization.⁵⁰ The solid lines flowing downward indicate the primary information flow and the dotted lines flowing upward depict the flow of feedback.

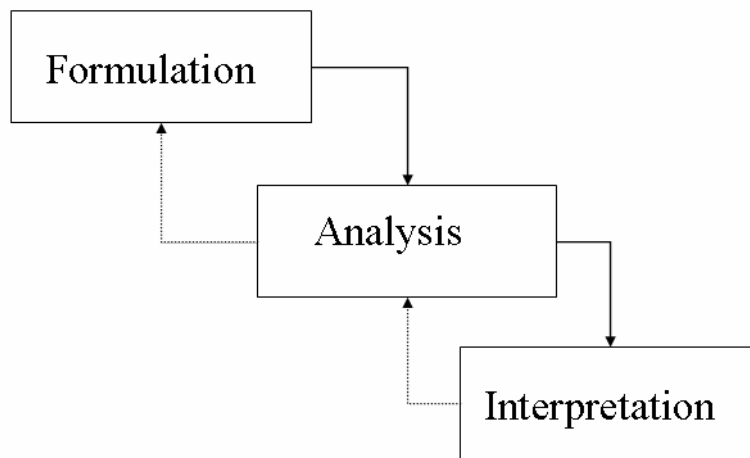

Figure 5. An Analytical Framework Used Throughout the Systems Engineering and Analysis Process.⁵¹

1.6.2 Systems Architecture

“Architecture as the scheme of arrangements of the components of a system, and it describes features that are repeated throughout the design and explains the relationship among the system’s parts.”⁵²

Systems architecture begins with the system's operational concept and includes the development of three separate architectures (functional, physical, and operational) as part of this decomposition. The functional architecture defines what the system must do, that is, the system's functions and the data that flows between them. The physical architecture represents the portioning of physical resources available to perform the system's functions. Figure 6 suggests that the functional and physical architectures are developed independently of each other and then combined to form the operational architecture. This suggestion is inaccurate, rather the two architectures are developed in parallel, but with close interaction to ensure that the operational architecture is meaningful when the functional and physical architectures are combined.⁵³

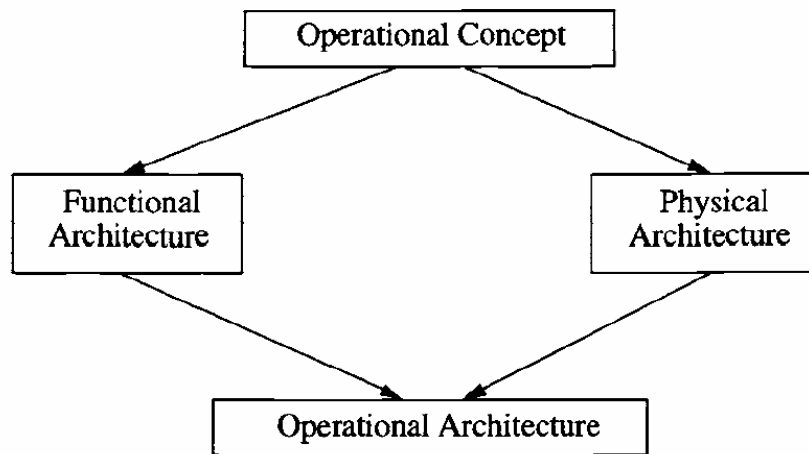

Figure 6. Systems Architecture⁵⁴

An operational concept is a vision for what the system is (in general terms), a statement of mission requirements, and a description of how the system will be used. The shared vision is from the perspective of the system's stakeholders, addressing how the system will be developed, produced, deployed, trained, operated and maintained, refined, and retired to overcome some operational problem and achieve the stakeholders' operational needs and objectives. Figure 7 shows the primary choices that were considered by the National Aeronautics and Space Administration (NASA) engineers in determining an operational concept for landing on the moon during the 1960s.⁵⁵

In section two of this technical report the RST has developed an in-depth riverine sustainment operational concept.

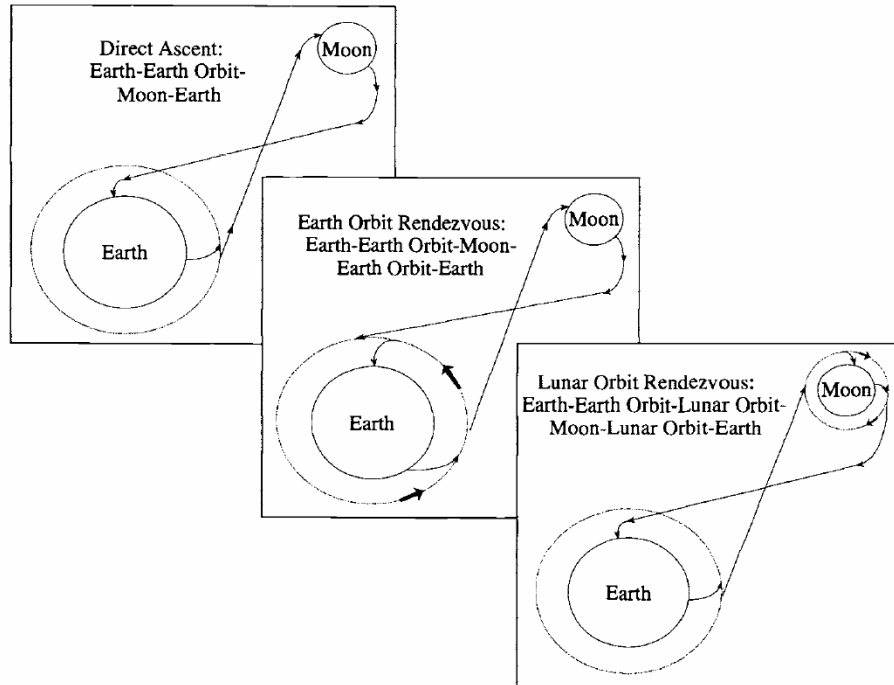

Figure 7. Alternate operational concepts for Apollo's moon landing.⁵⁶

Time-tested engineering of systems has shown that the design process for a system has to consider more than the physical side of the system; the functions or activities that the system has to perform are a critical element for the design process to be successful on a consistent basis. This is not to say that the designs of functions and physical resources for the system proceed independently; they cannot. However, for success these two design elements must be equal partners in the design process, providing checks on each other and complementing each other's progress. The functional architecture of a system contains a hierarchical model of the functions performed by the system, the system's components, and the system's configuration items (CI's); the flow of informational and physical items from outside the system through the transformational processes of the system's functions and on to the system's items; and a tracing of input/output requirements to both the system's functions and items.⁵⁷

The physical architecture of a system is a hierarchical description of the resources that comprise the system. This hierarchy begins with the system and the system's top-level components and progresses down to the CI's that comprise each intermediate component. The CI's can be hardware or software elements or combinations of hardware and software, people, facilities, procedures, and documents (e.g., user's manuals).⁵⁸

There are two kinds of physical architectures: generic and instantiated.

The generic physical architecture defines the hierarchy in general terms, for example, two processors with associated software, a person, and a building. The instantiated physical architecture lays out the specifics of the processors, software, person, and building in enough detail to permit performance modeling of the system related to the requirements being addressed. The intent of systems engineers should not be to design these components but rather to state representative instantiations for the generic components that are sufficient to model the performance of the system and ensure that the requirements decomposition process makes sense.

The exit criterion for the development of the physical architecture is the provision of a single physical architecture that is satisfactory in terms of detail, quantity, and quality for development of the operational architecture. This satisfaction of detail, quantity, and quality is typically preceded by the creation of several alternate physical architectures for consideration during the development and refinement of the operational architecture.⁵⁹

The development process for the operational architecture is the activity during which the entire design comes together. The operational architecture integrates the requirements decomposition with functional and physical architectures. The process of developing the operational architecture provides the raw materials for the definition of the system's external and internal interfaces and is the only activity in the design process that contains the material needed to model the system's performance and enable trade-off decisions. The design process is like peeling onion; each of these activities in the design process should be completed at a high level of abstraction (low level of detail), culminating in an operational architecture at this high level of abstraction for a set of sub-systems that comprise the system. Then the entire process is repeated at lower levels of abstraction (greater detail) for the next tier of components (peel of the onion). This repetition at lower and lower levels of abstraction (greater and greater detail) is continued as long as useful to the design process. As details determine problems with the design, decisions are reviewed and changes are implemented at the higher levels of abstraction as needed.⁶⁰

1.6.3 Joint Capabilities Integration and Development System

The Joint Capabilities Integration and Development System (JCIDS) is a joint-concepts-centric capabilities identification process that allows joint forces to meet future military challenges. The Joint Capabilities Integration and Development System process assesses existing and

proposed capabilities in light of their contribution to future joint concepts. JCIDS, supported by robust analytic processes, identifies capability gaps and potential solutions. While JCIDS considers the full range of doctrine, organization, training, materiel, leadership and education, personnel and facilities (DOTMLPF) solutions, for purposes of this Guidebook, the focus remains on the pursuit of materiel solutions.⁶¹

1.6.4 RST Systems Engineering Design Process

Systems engineering is rooted in problem solving and seeks to apply an organized, analytical process to the development of solutions to complex problems. The process begins with identification of a want or desire for something and is based on a real or perceived deficiency.⁶²

The RST utilized proven systems engineering principles and architectures to define, analyze, and interpret riverine sustainment in 2012. The RST also incorporated the DOTMLPF process to develop feasible alternatives for RF sustainment. Finally, the RST used Buede's functional, physical, and operational architectures as a blueprint for the analysis.

1.6.5 Project Management Plan

The Project Management Institute (PMI), the leading certification body for project management, defines project management as: the application of knowledge, skills, tools, and techniques to project activities to meet project requirements. Seasoned project teams view managing requirements and the project scope as the most critical elements of managing the project. The Project and its requirements start with expressed needs and end only those needs are satisfied as evidenced by successful user validation.⁶³

The needs are met for the RST when the revised problem statement is addressed completely.

Once technical and business requirements are established as consistent, the balance needs to be maintained. The budget and schedule must enable achievement of the technical requirements. Conversely, the technical requirements must be achievable with the budget and schedule. Projects without congruency at the outset are usually doomed and unrecoverable unless the inconsistencies are resolved early. In some industries, projects of this type are known as a suicide run. Throughout a project's duration, there is continual pressure to change the established agreements.

Schedules are compressed, available resources decreased, and technical features added. The project team must be able to recognize and respond to serious inconsistencies. When implementing schedule, budget, and technical changes, congruency must be reestablished or the project will fail.⁶⁴

Communication problems are the root cause of many project failures. Miscommunication routinely leads to conflict that can destroy teamwork. Communicating is difficult enough in familiar work, social, and family settings. The project environment can be particularly challenging. Due to their temporary nature, projects often bring together people who were previously unknown to each other, which is reason enough for miscommunication, especially in the early project phases.⁶⁵

At the beginning of the riverine sustainment project, not only was the RST divided by several thousand miles of ocean, there were cultural and language barriers as well. The RST mitigated some of the barriers with a video teleconference (VTC) in mid-November 2006. During VTC both SEA-11 and TDSI students were able to share project concerns and ideas. Afterward the students continued to discuss the study via email. Upon arrival of the TDSI students on the NPS campus in early January 2007, the RST met to share personal expertise, preferences, and expectations. From that very first meeting the entire RST knew their role and what was expected of them.

Teamwork, so essential to effective project performance, receives considerable attention today. We want our project staffs to become empowered teams – perhaps even self-directed teams.⁶⁶

The RST organized its member into functional IPT's (that addressed certain facets of the riverine sustainment problem) that would build on their personnel strengths and preferences.

An appropriate project cycle contributes significantly to doing the right project right the first time. The project cycle as an orderly sequence of integrated activities, performed in phases leading to success.⁶⁷

As depicted in Figure 8, the RST broke the project into three phases: definition, development, and modeling/analysis.

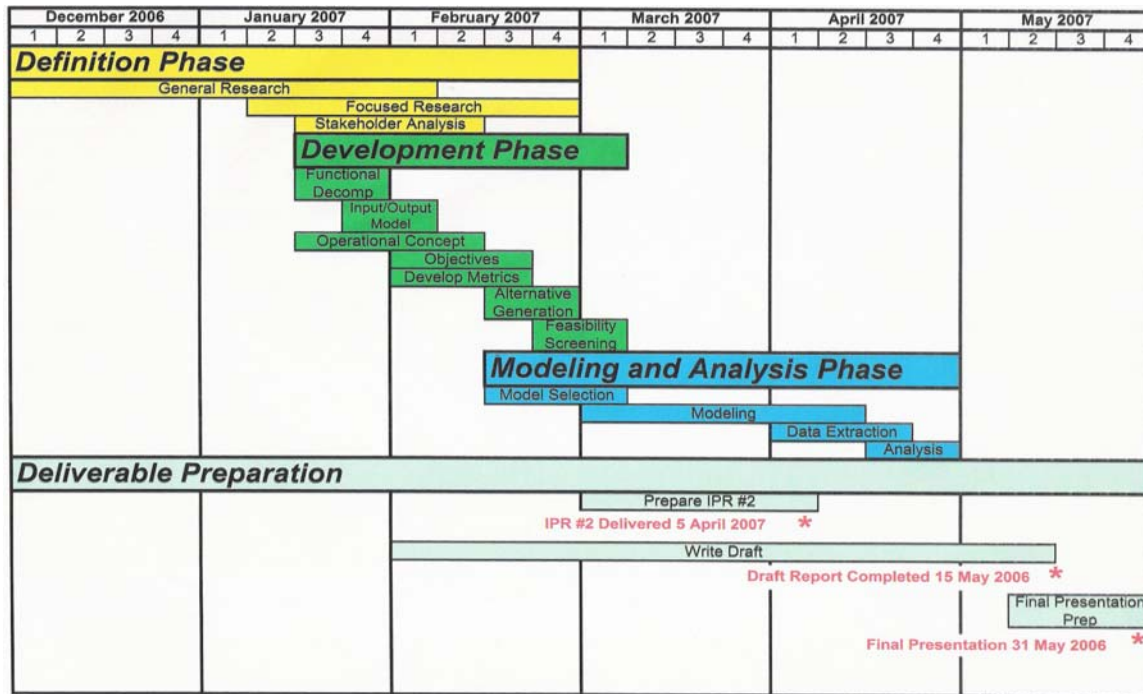

Figure 8. RST Project Cycle

The project cycle clearly articulated where the RST should be with respect to time. In addition to the project cycle, the RST developed work break-down structures (WBS's) for each IPT and for the overall project. The WBS's established what needed to be accomplished by which party and by when, significantly increasing accountability.

1.7 ASSUMPTIONS

- Current Operations in Iraq are an anomaly and MSO and TSC operations are pivotal mission for the RF.
- Future areas of interest are the Africa, South America, and Southeast Asia
- Minus POL, the RF must be capable of sustaining itself for 15 days prior to re-supply.
- Kampar River is representative of many, but not all, riverine operating environments.
- Area of Operation on the Kampar River is logistically barren.

- RF will encounter level II threats that are small unconventional warfare forces armed with small arms and crew-served weapons.
- An abundance of crude oil exists in the AO, Diesel Fuel-Marine (DFM) is in high demand and is a target of insurgent forces
- The riparian environment has relatively large numbers of indigenous population and insurgency operations distributed among the local people and urban areas.

⁸ Naval Expeditionary Combat Command, *U. S. Navy Riverine Group, Concept of Operations*, 28 September 2006 (Little Creek, VA: GPO, 2006), 22.

⁹ James W. Beaver and others, “Systems Analysis of Alternative Architectures for Riverine Warfare in 2010” (MS diss., Naval Postgraduate School, 2006), 1.

¹⁰ Chief of Naval Operations remarks as delivered at the National Defense Industry Association Expeditionary Warfare Conference, Panama City, FL., 26 Oct. 2005, <http://www.navy.mil/navydata/leadership/quotes.asp?q=11&c=6>.

¹¹ Naval Expeditionary Combat Command, “About Us,” *Naval Expeditionary Combat Command*, <http://www.necc.navy.mil/>.

¹² Mandy McLaurin, “Navy Establishes First Riverine Group,” *Navy newsstand*, May 26, 2006, http://www.navy.mil/search/display.asp?story_id=23854.

¹³ Naval Expeditionary Combat Command, *U. S. Navy Riverine Group, Concept of Operations*, 28 September 2006 (Little Creek, VA: GPO, 2006), 7.

¹⁴ Center for Naval Analyses, *Renewal of Navy’s Riverine Capability: Resource Implications for Combat Support/Combat Service Support and TSC*, January 2006 (Alexandria, VA: GPO, 2006), 11.

¹⁵ Chief of Naval Operations remarks as delivered at the Naval War College, Newport, RI, 31 August 2005, <http://www.navy.mil/navydata/leadership/quotes.asp?q=11&c=6>.

¹⁶ U.S. Department of Defense, *Joint Publication 3-0: Joint Operations*, 17 September 2006 (Washington D.C.: GPO, 2006), 28.

¹⁷ U.S. Department of Defense, *Joint Publication 1-02: Department of Defense Dictionary of Military and Associated Terms*, 1 March 2007 (Washington, D.C.: GPO, 12 April 2001), 517.

¹⁸ Global Security, “Classes and Subclasses of Supply,” *Global Security.org* <http://www.globalsecurity.org/military/intro/supclass.htm>.

¹⁹ U.S. Department of Defense, *Joint Publication 1-02: Department of Defense Dictionary of Military and Associated Terms*, 1 March 2007 (Washington, D.C.: GPO, 12 April 2001), 457.

²⁰ Global Security, “Small Unit Riverine Craft (SURC),” *Global Security.org* <http://www.globalsecurity.org/military/systems/ship/surc.htm>.

-
- ²¹ U.S. Department of Defense, *Joint Publication 3-0: Joint Operations*, 17 September 2006 (Washington D.C.: GPO, 2006), 24.
- ²² Sun Tzu, *The Art of War*, trans. and ed. Ralph D. Sawyer (Boulder, CO, Westview Press, 1994), 57.
- ²³ U.S. Department of Defense, *Joint Publication 1-02: Department of Defense Dictionary of Military and Associated Terms*, 1 March 2007 (Washington, D.C.: GPO, 12 April 2001), 101.
- ²⁴ U.S. Department of Defense, *Joint Publication 3-0: Joint Operations*, 17 September 2006 (Washington D.C.: GPO, 2006), I-1.
- ²⁵ U.S. Department of the Navy – Naval Historical Center, *Riverine Warfare: The U.S. Navy's Operations on Inland Waters* (Washington, DC: GPO, 1965).
- ²⁶ E.M. Eller, introduction to *Riverine Warfare: The U.S. Navy's Operations on Inland Waters* by U.S. Department of the Navy – Naval Historical Center (Washington, DC: GPO, 2006).
- ²⁷ Wayne E Meyer Institute, Memorandum sent to the authors, 6 December 2006.
- ²⁸ U.S. Department of the Navy, *Highlights of the Department of Navy FY2008 Budget* (Washington DC: GPO, 2007), 1-9.
- ²⁹ Temasek Defence Systems Institute, "Strategic Alliance," *Temasek Defence Systems Institute*, http://www.tdsi.nus.edu.sg/about_strategic_alliance.html.
- ³⁰ Wayne E Meyer Institute, Memorandum sent to authors, 6 December 2006.
- ³¹ Chief of Naval Operations remarks as delivered at the National Defense Industry Association Expeditionary Warfare Conference, Panama City, FL, 26 Oct. 2005, <http://www.navy.mil/navydata/leadership/mist.asp?x=S>.
- ³² Naval Expeditionary Combat Command, *U. S. Navy Riverine Group, Concept of Operations*, 28 September 2006 (Little Creek, VA: GPO, 2006), 9.
- ³³ Andrew P. Sage and James E. Armstrong Jr., *Introduction to Systems Engineering* (New York: John Wiley & Sons, 2000), 98.
- ³⁴ Central Intelligence Agency, "Indonesia," *CIA – The World Factbook*, <https://www.cia.gov/cia/publications/factbook/geos/id.html>.

³⁵ United Nations, “Land Geography,” *The Republic of Indonesia*, <http://www.un.int/indonesia/Indonesia/Indonesia/indoninfo.html>.

³⁶ *MSN Encarta*, s.v. “The Republic of Indonesia - Coastline,” http://encarta.msn.com/encyclopedia_761573214_2/Republic_of_Indonesia.html (accessed January 24, 2007).

³⁷ United Nations, “Climate and Weather,” *The Republic of Indonesia*, <http://www.un.int/indonesia/Indonesia/Indonesia/indoninfo.html>.

³⁸ *MSN Encarta*, s.v. “The Republic of Indonesia - Climate,” http://encarta.msn.com/encyclopedia_761573214_2/Republic_of_Indonesia.html (accessed January 24, 2007).

³⁹ Naval Expeditionary Combat Command, *U. S. Navy Riverine Group, Concept of Operations*, 28 September 2006 (Little Creek, VA: GPO, 2006), 13.

⁴⁰ Naval Expeditionary Combat Command, *U. S. Navy Riverine Group, Concept of Operations*, 28 September 2006 (Little Creek, VA: GPO, 2006), 45-46.

⁴¹ Center for Naval Analyses, *Renewal of Navy’s Riverine Capability: Resource Implications for Combat Support/Combat Service Support and TSC*, January 2006 (Alexandria, VA: GPO, 2006), 43.

⁴² Karin Mast, “Temporary Forward Operating Base Site Opens With Medical Task Force Training,” *Triad Online*, <http://www.mccoys.army.mil/readingroom/triad/04222005/TemporaryFOBase.htm>.

⁴³ Elmer L. Roman, “Trip Report for the Office of Naval Research Global – Latin America Office visit to the Columbian Navy R&D Institutions, 28-30 June 2006,” (report presentation, Washington, DC, 28-30 June 2006).

⁴⁴ Center for Naval Analyses, *Renewal of Navy’s Riverine Capability: Resource Implications for Combat Support/Combat Service Support and TSC*, January 2006 (Alexandria, VA: GPO, 2006), 8.

⁴⁵ Naval-Technology.com, “Cut Away View of an LPD-17,” *LPD 17 (San Antonio Class) Landing Platform Dock, USA*, <http://www.naval-technology.com/projects/lpd17/lpd1710.html>.

⁴⁶ Andrew P. Sage and James E. Armstrong Jr., *Introduction to Systems Engineering* (New York: John Wiley & Sons, 2000), 53.

-
- ⁴⁷ Andrew P. Sage and James E. Armstrong Jr., *Introduction to Systems Engineering* (New York: John Wiley & Sons, 2000), 8-9.
- ⁴⁸ Dennis M. Buede, *Engineering Design of Systems: Models and Methods* (New York: John Wiley & Sons, 2000), 6.
- ⁴⁹ Andrew P. Sage and James E. Armstrong Jr., *Introduction to Systems Engineering* (New York: John Wiley & Sons, 2000), 32-33.
- ⁵⁰ Andrew P. Sage and James E. Armstrong Jr., *Introduction to Systems Engineering* (New York: John Wiley & Sons, 2000), 50.
- ⁵¹ Andrew P. Sage and James E. Armstrong Jr., *Introduction to Systems Engineering* (New York: John Wiley & Sons, 2000), 51.
- ⁵² Andrew P. Sage and James E. Armstrong Jr., *Introduction to Systems Engineering* (New York: John Wiley & Sons, 2000), 168.
- ⁵³ Dennis M. Buede, *Engineering Design of Systems: Models and Methods* (New York: John Wiley & Sons, 2000), 19-20.
- ⁵⁴ Dennis M. Buede, *Engineering Design of Systems: Models and Methods* (New York: John Wiley & Sons, 2000), 20.
- ⁵⁵ Dennis M. Buede, *Engineering Design of Systems: Models and Methods* (New York: John Wiley & Sons, 2000), 139.
- ⁵⁶ Dennis M. Buede, *Engineering Design of Systems: Models and Methods* (New York: John Wiley & Sons, 2000), 139.
- ⁵⁷ Dennis M. Buede, *Engineering Design of Systems: Models and Methods* (New York: John Wiley & Sons, 2000), 175.
- ⁵⁸ Dennis M. Buede, *Engineering Design of Systems: Models and Methods* (New York: John Wiley & Sons, 2000), 215.
- ⁵⁹ Dennis M. Buede, *Engineering Design of Systems: Models and Methods* (New York: John Wiley & Sons, 2000), 216.
- ⁶⁰ Dennis M. Buede, *The Engineering Design of Systems: Models and Methods* (New York: John Wiley & Sons, 2000), 245.

⁶¹ Defense Acquisition University, “Joint Capabilities Integration and Development System,” *Defense Acquisition University*, http://akss.dau.mil/dag/DoD5000.asp?view=document&rf=GuideBook\IG_c1.3.asp.

⁶² Benjamin S. Blanchard and Wolter J. Fabrycky, *Systems Engineering and Analysis*, 4th ed. (Upper Saddle River, NJ: Pearson Education, 2006), 55-56.

⁶³ Kevin Forsberg, Hal Mooz, and Howard Cotterman, *Visualizing Project Management: Models and Frameworks for Mastering Complex Systems*, 3rd ed. (Hoboken, NJ: John Wiley & Sons, 2005), 5.

⁶⁴ Kevin Forsberg, Hal Mooz, and Howard Cotterman, *Visualizing Project Management: Models and Frameworks for Mastering Complex Systems*, 3rd ed. (Hoboken, NJ: John Wiley & Sons, 2005), 5-6.

⁶⁵ Kevin Forsberg, Hal Mooz, and Howard Cotterman, *Visualizing Project Management: Models and Frameworks for Mastering Complex Systems*, 3rd ed. (Hoboken, NJ: John Wiley & Sons, 2005), 48.

⁶⁶ Kevin Forsberg, Hal Mooz, and Howard Cotterman, *Visualizing Project Management: Models and Frameworks for Mastering Complex Systems*, 3rd ed. (Hoboken, NJ: John Wiley & Sons, 2005), 70.

⁶⁷ Kevin Forsberg, Hal Mooz, and Howard Cotterman, *Visualizing Project Management: Models and Frameworks for Mastering Complex Systems*, 3rd ed. (Hoboken, NJ: John Wiley & Sons, 2005), 84.



THIS PAGE INTENTIONALLY LEFT BLANK

2. OPERATIONAL CONCEPT

2.1 OVERVIEW

The Joint Chiefs of Staff state that an operational concept:

Is how the commander plans to accomplish the mission, including the forces involved; the phasing of operations; the general nature and purpose of operations to be conducted; and the interrelated or cross-Service support. They should be sufficiently developed to include an estimate of the level and duration of conflict to provide supporting and subordinate commanders a basis for preparing adequate support plans.⁶⁸

Buede elaborates:

The developments of the operational concept serves the purpose of obtaining consensus in the written language of the stakeholders about what needs the system will satisfy and the ways in which the system will be used. By describing how the system will be used, the operational concept is providing substantial (but incomplete) information about the system's interaction with other systems and the context of the system.⁶⁹

The operational concept includes a collection of scenarios, one or more for each group of stakeholders in each relevant phase of the system's life cycle. Each scenario addresses one way that a particular stakeholder will want to use, deploy, and fix the system; the scenario defines how the system will respond to inputs from other systems in order to produce a desired output. Included in each scenario are the relevant inputs to and outputs from the system and the other systems that are responsible for those inputs and outputs. The scenario should not describe how the system is processing inputs to produce outputs; rather the scenario focuses on the exchange of inputs and outputs by the system with other systems. It is critical that this shared vision be consistent with the collection of scenarios comprising the operational concept.⁷⁰

The RST operational concept serves as a roadmap for short notice RF operations in the 2012 time frame. Emphasis is on short notice RF deployment to logistically barren environments.

The RF group will be both inter- and intra-theater deployable. Effectiveness in the identified mission areas demands these units be quickly packaged and deployed from cases in the U.S. This force will be ready to deploy within 96 hours from notification. This will be

accomplished by ensuring most equipment is airmobile and all equipment is sea transportable⁷¹

The RF is well suited to perform Maritime Security Operation missions, but not direct combat versus a large organized armed force. The RF has a very limited capability to conduct high tempo/high intensity missions.⁷²

Given the RF's limitations, they are better suited for operation in a lower threat level environment as depicted in Figure 9.

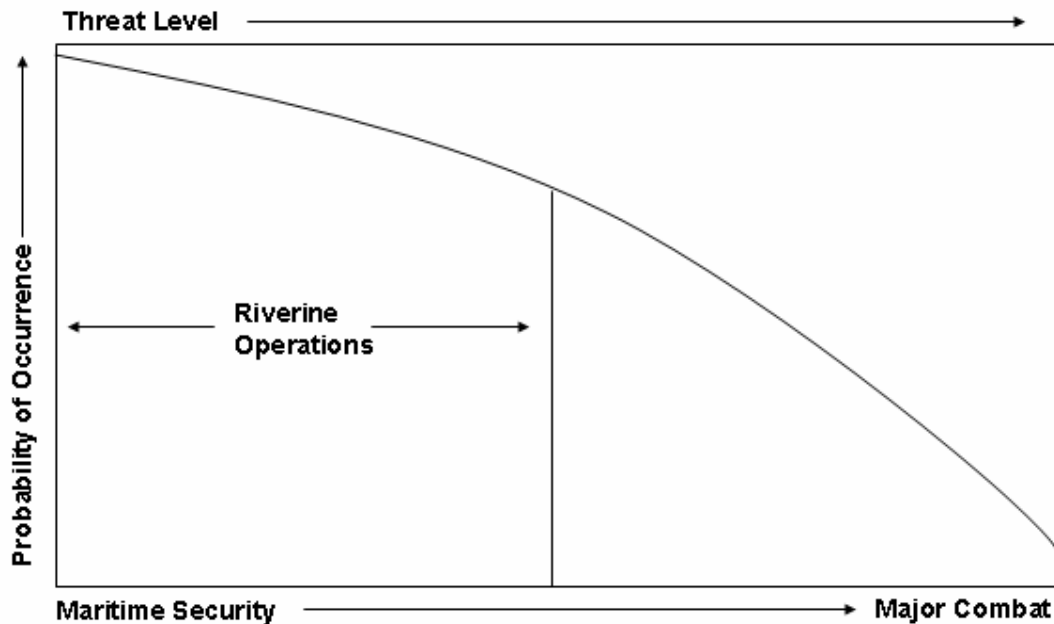

Figure 9. US Military Operations Spectrum

The Kampar River in the coastal wetland of western Sumatra, Indonesia, was used to represent a logistically barren AO. The Kampar river has the fourth highest ship density in Indonesia, but its river banks are lightly populated. Isolated, densely vegetated terrain and cultivated land characterize the land masses on either side of the Kampar. The RF deployed for six months to the island of Sumatra to conduct phase 0 shaping operations (as depicted in Figure 10) to stem the tide of insurgent activity.

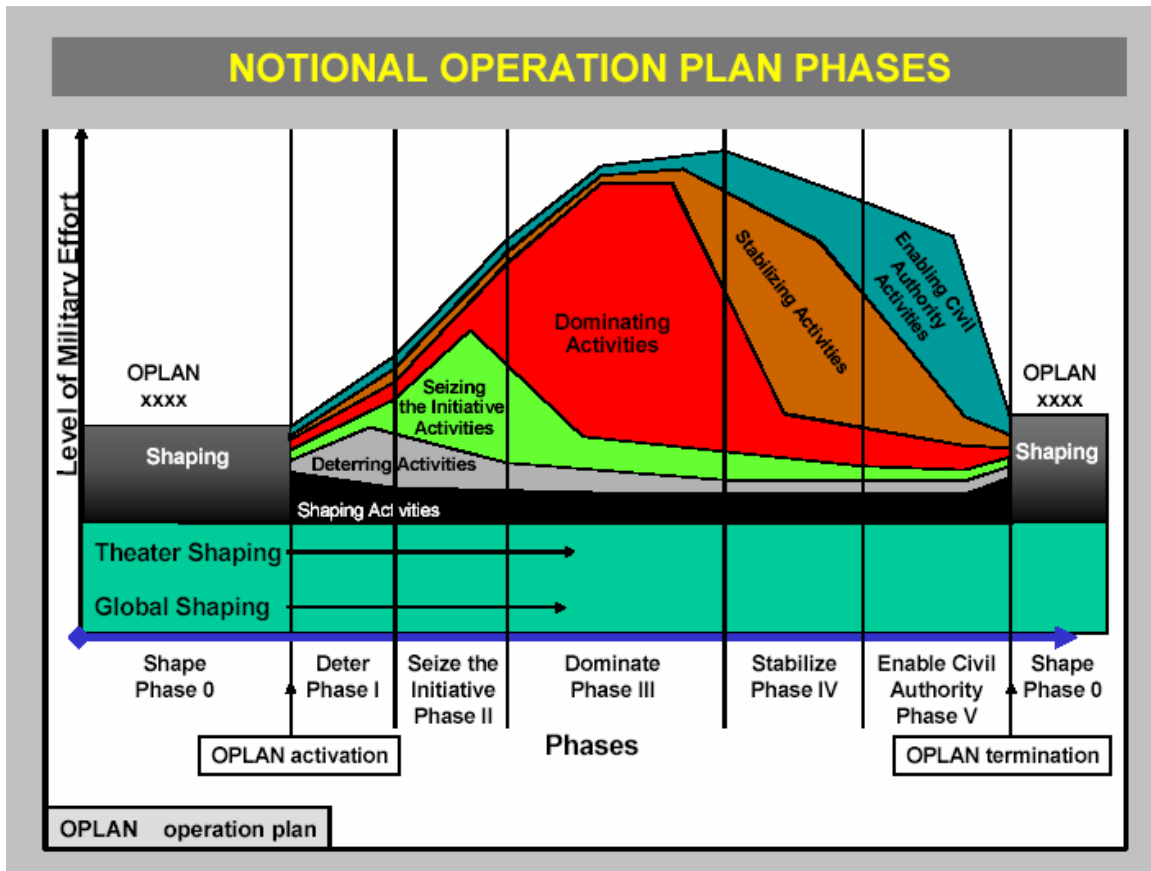

Figure 10. U.S. Operating Phases⁷³

“A phase is a definitive stage of an operation or campaign during which a large portion of the forces and capabilities are involved in similar or mutually supporting activities for a common purpose.”⁷⁴

Phasing is a helpful method for defining requirement for an entire operation or campaign. It assists the war-planners in identifying such requirements in terms of forces, resources, time, space, and purpose. There are six distinct phases: shaping, deter, seize the initiative, dominate, stabilize, and enable civil authority. Phase 0 or shaping operations (RF domain), are conducted to shape or influence perceptions of friend and foe alike.⁷⁵

For the RF these engagements fall under either MSO or TSC operations. Shaping the strategic environment is vital to our national defense.

Specifically, the RF performed patrol and interdiction operations on the Kampar River to intercept and deter arms shipments into the region. Classified as a Level II

Threat (Table 2), the insurgents employed guerrilla tactics and utilized small arms, crew-served weapons, and mortars. The goal was to thwart terrorist activity and assist the Indonesian Government in stabilizing the region.

Levels of Threat	
Threat Level	Examples
Level I	Agents, saboteurs, sympathizers, terrorist, civil disturbances
Level II	Small tactical units, unconventional warfare forces, guerrillas, may include significant stand-off weapons threats
Level III	Large tactical force operations, including airborne, <u>heliborne</u> , amphibious, infiltration, and major air operations

Table 2. Threat Levels⁷⁶

Desiring a long-term effect, a mobile training team (MTT), consisting of six instructors, was deployed as a part of the RF. For the duration of the operation, the MTT trained Indonesian military and paramilitary forces in riverine warfare tactics and operations. Enabled by the hands-on training the Indonesian forces assumed patrol and interdiction operations of the Kampar River at the conclusion of the RF deployment.

2.2 OPERATIONAL PHASES

Four phases were identified for RF planning purposes: pre-deployment, deployment, and withdrawal. Pre-deployment phase activities prepare the AO for the arrival of the RF.

Deployment encompasses the movement of forces and their sustainment resources from their original locations to a specific destination to conduct joint operations. Employment encompasses the use of military forces and capabilities within an operational AO. Sustainment is the provision of logistics and personnel services required to maintain and prolong operations until successful mission accomplishment. The focus of sustainment is to provide the force with the means to enable freedom of action and endurance and extend operational reach.⁷⁷

At the completion of operations, withdrawal of forces and resources to their origination is executed.

2.2.1 Pre-Deployment Phase

The pre-deployment phase consisted of battlespace preparation. Battle-space preparation activities included intelligence and environmental assessments of the AO and FOB construction (when the FOB is selected as the base alternative). “Deployment planning and execution, like all operations, are guided by joint intelligence preparation of the battlespace for the full range of military operations. The impact of the operational environment and the adversary must be assessed in relation to the assigned mission.”⁷⁸

Environmental (hydrographic/topographic) surveys were conducted in parallel to the intelligence assessment to reveal geographic constraints and assist in locating appropriate sites for the FOB and MOB. In choosing a site for the FOB, force protection and logistic feasibility were considered. An area approximately 10 miles east of the city of Telukmeranti was selected for the location of the FOB. The NECC rapidly deployed a detachment from the Naval Construction Division (SeaBees) with equipment and construction materials to the site to construct the FOB. Modifying an existing tent camp model, the Seabees constructed a tailor-made FOB that supported the various RF requirements. First a security perimeter was established and remote force protection sensors were deployed. Next the TOC, latrine, messing, and SURC maintenance facilities were built. Designated SURC and helicopter re-fueling areas were reinforced with dirt and sand bag walls for additional protection. Finally, personnel tents and storage areas were erected.

2.2.2 Deployment Phase

During deployment, units are echeloned, configured and scheduled for movement based on time-phased force and deployment data that synchronizes arriving personnel, equipment, and materiel with mission needs. Time phasing allows for rapid theater reception and onward movement of arriving personnel, equipment, and materiel.⁷⁹

The most critical nodes supporting most deployment operations are the air and seaports of embarkation and debarkation. Port efficiency or throughput is a function of the operational environment, capability of the port workforce, and level of port modernization. In some instances, the existence of no port facilities (e.g., bare beach or austere landing strip)

will significantly hinder deployment and sustainment operations until temporary or fixed infrastructure can be considered.⁸⁰

The Kampar River area is logistically barren with no port facilities or suitable airports.

Lines of Communications (LOC's) are the land, water, and air routes which connect an operating military force with a base of operations and along which supplies and military forces move to support operations. LOC's must be identified early in the planning process because the associated links (e.g., land, sea, or air routes) and nodes (e.g., home station, ports, staging areas, and destination) impact every aspect of deployment planning.⁸¹

The AO has very few improved roadways and during the rainy season most of its roads are impassable (RF deployed during the rainy season), thus eliminating land routes for deployment and sustainment considerations.

“A river squadron can be transported to a theater of operations by air, amphibious ship, or merchant vessel.”⁸² Airlift was by far most expeditious way of moving the RF, however the AO was not serviced by an adequate airport. Even if a regional airport did exist the majority of the regional roadway would be impassable due to torrential rains. “Amphibious ships have sufficient billeting and vehicle square footage to accommodate the RF”⁸³ Amphibious assault ships (LHA/LHD's), amphibious transport docks (LPD's), and tank landing ships (LST's) are all desirable for RF transportation due to their large cargo capacities, berthing and well-decks.

The RF minus the pre-deployment compliment of Seabees and security personnel were staged in Little Creek, Virginia for inter-theater transport aboard an amphibious ship.

Staging is the process of concentrating troop units, transient personnel, and materiel between movements over LOC's for mission-related purposes. Purposes for staging may include, but are not limited to, any of the following mission related activities: operational pause for rest, reorganization, or reconstitution of the force; reconfiguration of the unit loads or movement echelons for employment; pre-deployment training; rehearsal of unit missions; marshalling of forces; or to change the mode of transportation.⁸⁴

Figure 11 demonstrates deployment of a landing craft from the well-deck of an amphibious ship.



Figure 11. Amphibious Deployment Operations⁸⁵

Successful deployments were characterized by careful planning and flexible execution. Careful and detailed planning ensures that only required personnel, equipment, and materiel are scheduled for movement, unit movement changes were minimized, and the flow of personnel, equipment, and materiel into theater does not exceed lift availability and the theater reception capability.⁸⁶

2.2.3 Employment Phase

“Employment was the strategic, operational, or tactical use of forces”⁸⁷
Employment spans the phases of operation and incorporates all the activities required to complete the assigned mission. The employment phase is by far the longest phase and is not completed until the mission is completed.⁸⁸ Once in the AO, the RF was employed from one of three basing alternatives: FOB, MOB, or GFS. The FOB was ashore approximately 30 miles up the Kampar River along the riverbank and had ample space

for the RF and its materiel. The MOB was also 30 miles up river, but it is afloat in the Kampar River. The GFS was afloat as well, but it is 10 miles off the coast of Sumatra in a more permissive environment. From their support base the RF was capable of conducting operations. There are five categories that Navy riverine operations will likely fall into: river control, riverine lines of communication interdiction, fire support, insertion/extraction, and theater security cooperation. These five operation categories have distinct characteristics that have an affect force employment.⁸⁹

To be effective in the riverine environment, near continuous presence was required for river control. The overarching goal of river control is to not only control, but also to monitor the flow of traffic and goods on the river way. The RF utilized a division of SURC's (four) for coordination, flexibility and mutual support to patrol the river for insurgent activity. Protecting critical infrastructure, providing a secure area for the conducting of military operations and commerce, and supporting civil affairs efforts along the river were the objectives of river control. RF requirements are:

- Conduct patrols
- Conduct Visit, Board, Search and Seizure (VBSS)
- Engage hostile forces on the river up to a level II threat
- Coordinate and cooperate with joint forces or other coalition partners.

Interdiction of riverine lines of communication involves impeding, disrupting or eliminating the means of movement of enemy personnel or supplies on the rivers or waterways accomplishes. Interdiction denies the enemy secure areas in which to operate and affords a secure area for friendly forces to maneuver and operate. Diligent battlespace intelligence preparation, careful planning, and persistent intelligence, surveillance and reconnaissance are vital to this operation⁹⁰

The third and fourth RF mission areas are fire support and insertion/extraction mission. Close coordination with joint and host nation forces are paramount in any fire support activity. The SURC's gun systems (MK-43, MK-19, and M-2) are capable of providing fire support for ground elements. With its armament, maneuverability, range,

and speed the SURC is an excellent platform is an excellent platform for insertion and extraction of ground forces.

The final primary mission area for the RF is TSC which vital in shaping the strategic environment. The host nation must trust the RF's intentions order to gain access to a country's territorial waters.⁹¹ These missions primarily focus on providing training or disaster relief to coalition partner nations. The footprint for TSC operations is typically small over short durations and is well suited for GFS basing. TSC missions assure allies, dissuade adversaries, and deter aggression.

2.2.4 Withdrawal Phase

At the end of the operation the RF transitions from the employment phase to the withdrawal phase. The RF in its entirety is transferred from the AO back to their homeport in Little Creek, Virginia. The withdrawal phase demands the same in-depth planning that the other phases require.

Withdrawal is not merely reversing the deployment process. Withdrawals are planned and executed as discrete, mission-based operations within the overall context of the joint force mission. Force protection is as important during withdrawal as during any other stage of the joint operation. During this transition period, the withdrawal unit may not be able to fully sustain or defend itself because some or all of its elements are configured for movement and may not have full mission capability. Equally important in the withdrawal process is a complete review of the environmental considerations applicable in the host nation environment. Failure to take the host nation requirements for environmental compliance into account may cause delays and dissatisfaction⁹²



Figure 12. Troop Withdrawal⁹³

2.3 RIVERINE SCENARIO

The purpose of this scenario was to set the stage for a riverine maritime interdiction operation in order to model and analyze alternative basing, sustainment, force protection, and repair architectures for the RF in a logistically barren environment. Aspects of this mission were developed to serve as a baseline to perform analysis and modeling on this operation to extract logistics, force protection, and repair requirements in determine how each of these requirements affected the various basing alternatives.

This particular area was chosen specifically for its geographical and hydrographical features. The political situation and scenario have been fictionalized and do not represent the current state of affairs in Indonesia.

2.3.1 Mission

In support of a request from the Government of Indonesia the U.S. Riverine Squadron One was tasked to conduct Riverine Maritime Interdiction Operations (MIO) along the Kampar River in the Riau Province in Indonesia in order to stem the tide of insurgent weapons and materiel traveling up the Kampar River that are supporting insurgent efforts to seize the city of Telukmeranti. The Riverine force was to patrol and

conduct MIO along a fifteen mile area downstream of the city of Telukmeranti (Figure 13) in a coalition effort with Indonesian forces. As requested by the Indonesian Government, this operation is to be conducted for a period of six months.

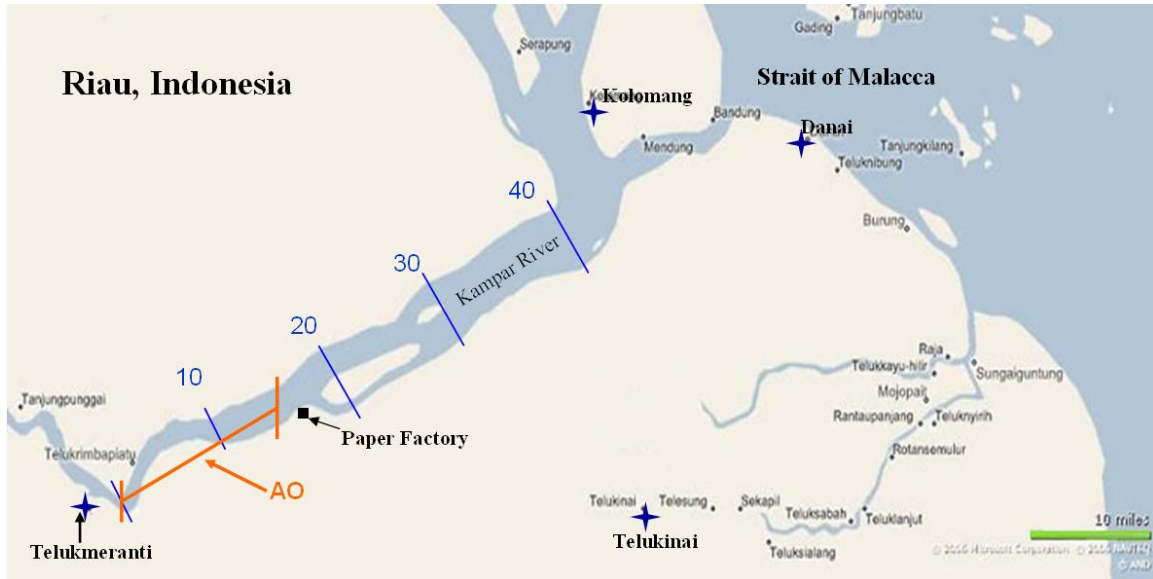

Figure 13. U.S. Riverine Force Area of Operations

As a coalition effort and a show of support for Indonesia, the U.S. deployed a Mobile Training Team (MTT) in order to train Indonesian forces on riverine operations. These Indonesian forces will be trained and deployed in the conduct of the MIO and will serve as interpreters and crewmembers on these missions. The U.S. forces will have a contingent of Indonesian military liaisons as a supplement to the Operation Center in order to expedite and coordinate U.S. and Indonesian military efforts.

2.3.2 Situation

Due to a weak economy, insurgent groups were attempting to overthrow the government of Indonesia. Small skirmishes have erupted in several of the major cities between the local law enforcement organizations and the insurgents. Indonesia declared a state of martial law and has dispatched its military and civil defense forces to these cities in order to restore peace. The Indonesian Government was not successful in thwarting insurgent actions, due to their inability to stop the flow of insurgent weapons and materiel throughout the country along its inland waterways. The insurgent weapons

and materiel were being transported into Indonesia from numerous points of origin. Since Indonesia had limited resources and poor diplomatic ties to most of these points of origins, Indonesia was seemingly left with one remaining option, stop the ingress and flow of insurgent weapons and materiel within their own borders.

Intelligence reports suggested that the insurgents have increased their efforts at moving weapons and materiel along the Kampar River in order to seize the city of Telukmeranti. The Mosque of Riau, located in Telukmeranti, is considered the Muslim religious center of Indonesia. It was felt that if Telukmeranti were to fall to the insurgents, that faith in the Indonesian Government would falter and increase insurgent sentiment and support in Indonesia that could possibly lead to the demise of the Indonesian Government.

In trying to stabilize the country and bolster support of the government, Indonesia requested the United States for assistance in helping them stop these insurgent shipments. The U.S. agreed to aid Indonesia in order to strengthen U.S. and Indonesian relations and show support for the Indonesian Government. However, the Indonesian government expressed concerns that it desires to limit the number of U.S. forces on Indonesian soil and limit U.S. Military action to MIO along the Kampar River. With the U.S. Military performing this specific task, the government of Indonesia felt that their own military and civil defense force could successfully restore peace to the region and maintain the local populations' confidence in the Indonesian Government.

The Indonesian Government also expressed concern that the U.S. efforts along the Kampar River should minimally impact commerce and traffic that would potentially weaken the Indonesian economy further. Due to this concern, the U.S. and Indonesia agreed that the U.S. would conduct MIO along the 15 nautical miles to the east of Telukmeranti. This particular patrol area was chosen for several reasons. In this area along the Kampar River, there is much less maritime traffic density, therefore fewer vessels to search and less impact on the local commerce and economy due to delays in searching additional vessels. This section of the river was also much narrower than other portions of the Kampar River. The Kampar River is over five nautical miles wide when it flows into the Strait of Malacca, however in this area, the river was on average 1.5

nautical miles wide making it more manageable to patrol and perform MIO. A tactical concern was that if the insurgents were on vessels that the likelihood of escape was greater the closer these vessels were to the Strait of Malacca due to the large traffic density of the Strait. Performing MIO up river away from the Strait of Malacca would give the U.S. forces increased time to overtake and contain evading insurgent vessels. This area was also chosen because there are no roads that lead into Telukmeranti past this region. If the base were closer to the Strait of Malacca, the insurgents might possibly bypass the U.S. efforts upon the river utilizing roads in the region and then use the river upstream to enter Telukmeranti. With the patrol area located near Telukmeranti, insurgents had only two options for transporting their weapons and materiel into Telukmeranti. These options were to try to evade the U.S. Riverine Force patrolling the river or move their weapons by land into Telukmeranti and contend with the Indonesian Army patrolling the region surrounding the city.

2.3.3 Considerations Affecting Possible Courses of Action

2.3.3.1 Terrain and Geography

The Riau Province in Indonesia is mostly coastal lowlands with the interior of the island having densely vegetated, tropical, mountainous terrain. The Kampar River region is densely vegetated coastal lowland with several small cities and cultivated areas along most of its banks. Elevation in the region is predominantly less than 100 feet above sea level. As depicted in Figure 14, the region north of the Kampar River is undeveloped forests and south of the Kampar River is undeveloped forest, a large lumber farm, and agricultural land.

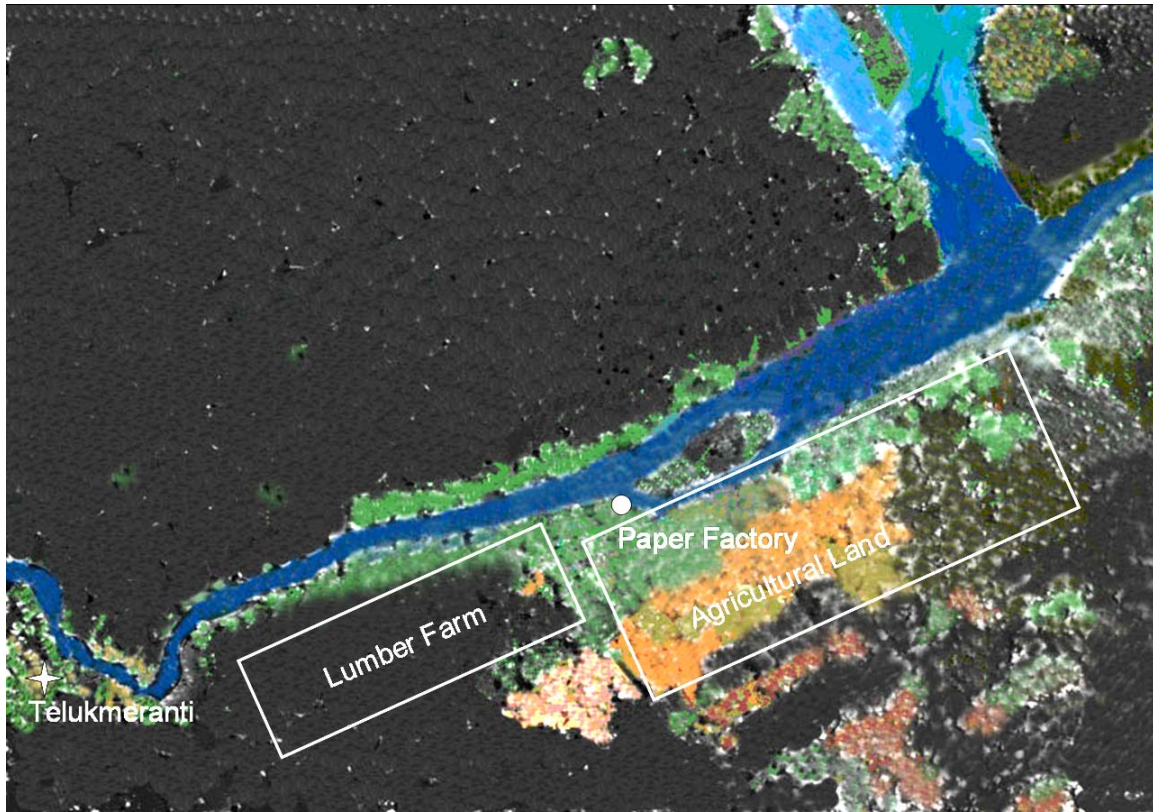

Figure 14. Kampar Region Terrain Features

2.3.3.2 Hydrography

The Kampar River is one of the four busiest inland waterways in Indonesia. The waterway is primarily used for the transportation of agricultural goods, logging, and textiles, namely paper. The Kampar River is navigatable to a large variety of ships for over 50 miles inland from the Strait of Malacca with an average depth of 4 to 5 fathoms.

2.3.3.3 Transportation

The Kampar River region ground transportation was limited to a few un-improved roads. Cross-country movement of vehicles is difficult due to the dense vegetation in the region; however wheeled vehicles can transverse on un-improved road throughout the few cultivated regions and lumber fields along the southern banks of the Kampar River. During the rainy season, in which region gets on average 80 to 120 inches of rainfall, the un-improved roads in this region were impassable due to the flooding and erosion.

Transportation in this region was primarily conducted upon the Kampar River. Fishing along the Kampar River was once the mainstay of the local economies in the regions. However, in the past few years, fishing in the region has become non-existent due to the pollution of the Kampar River by the paper mills along its southern banks. Maritime traffic upon the Kampar River consists of local merchant boats and small cargo boats and is summarized in the Table 3.

	Length (ft)	Draft (ft)	Gross Registered Tonnage	Max Speed (kts)	Average Ship Density per Day in Region
Local Merchant Ship	20-30	2-3 ft	<1	<10	100
Small Cargo Ship	85-120	6-14 ft	150-220	15	12

Table 3. Typical Regional Ship Characteristics

The local merchant ships were used for the transportation of local goods and personnel within the region. These small wooden boats had small crew cabins and have the capacity to embark up to 30 standing personnel. These vessels were powered by small outboard motors or push poles and transit in the shallow waters near the shores of the Kampar River. A typical Local Merchant ship is shown in Figure 15.

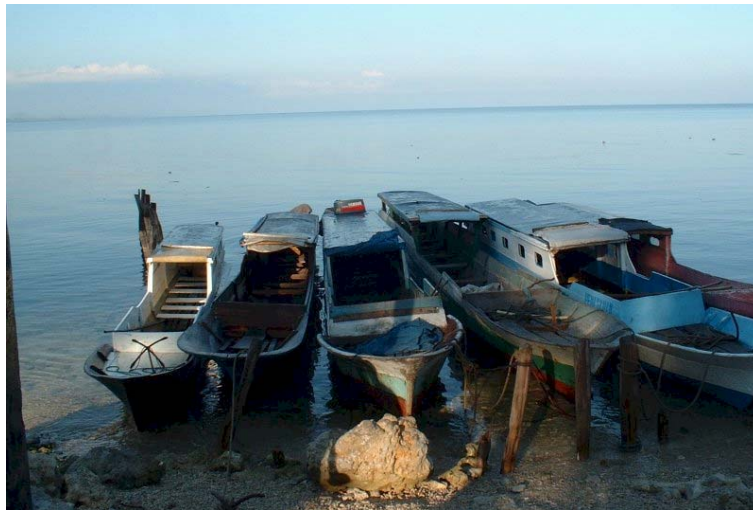

Figure 15. Typical Local Merchant Ships

The regional cargo ships were used for the transportation of commercial goods, such as paper and rubber, from the local industrial facilities to international ports along the Strait of Malacca. These steel vessels were characterized by small crew cabins and either one or two masts. A typical small regional cargo ship is shown in Figure 16.

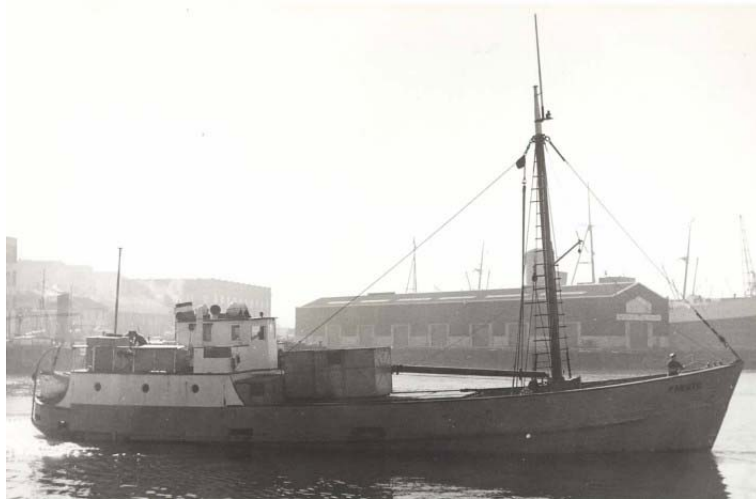

Figure 16. Typical Small Cargo Ship

2.3.3.4 Enemy Relative Combat Power

The Indonesian insurgents have limited capacity to conduct large offensive operations against standing forces. Insurgent weapons are currently limited to small arms (AK-74's), crew served weapons (RPG's), improvised explosive devices (IED's), and mortars (M-60's). Recent intelligence reports estimate insurgent strength to be approximately 500 personnel in the Kampar River region. These insurgents were dispersed among several cells. Insurgent areas of activity and estimated sizes are listed in the Figure 17.

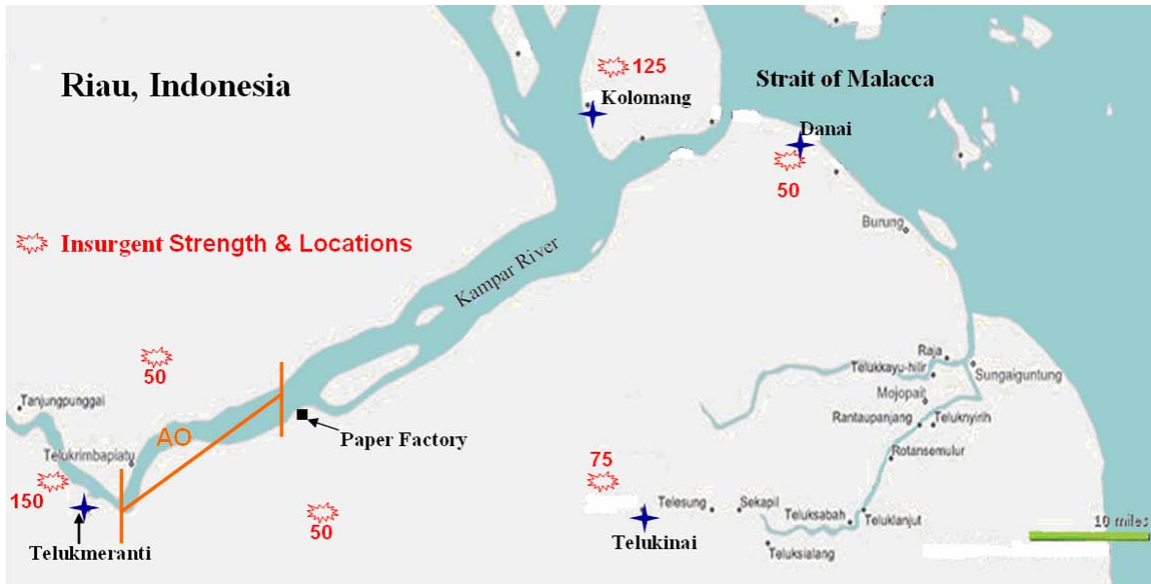

Figure 17. Approximate Insurgent Strength and Locations

2.3.3.5 Friendly Relative Combat Power

The Indonesian Military is approximately 200,000 personnel serving in the Army, Air Force, or Navy. Indonesia also employs a Universal People’s Defense which is approximately 100,000 civilians trained as territorial militia personnel. The Indonesian Navy, Customs Service, and Maritime Police have approximately 180 small craft which are utilized solely for coastal defense and port security. Indonesia has no dedicated riverine force.

Due to the importance of the Mosque of Riau in Telukmeranti, the Government of Indonesia has dispatched three thousand ground troops and a dedicated helicopter detachment to the Telukmeranti region. These troops are tasked with securing the city and protecting the Mosque of Riau. Indonesian forces were to patrol the rainforest/un-improved regions surrounding the city in an effort to stop the flow of insurgent weapons into the city from landward approaches. Indonesia established an outpost with approximately 200 military personnel within the U.S. area of operations in order to facilitate timely turnover of prisoners and render military assistance to U.S. Riverine Forces in the area.

The Indonesian Helicopter detachment consists of 6 Mi-2 helicopters located in the City of Telukmeranti and is tasked with providing direct air support and MEDIVAC/CASEVAC capabilities for both the Indonesian and U.S. forces. Three Mi-2 helicopters are configured to provide direct fire support while the remaining helicopters are configured to provide CASEVAC and lift functions. Through coordination with Indonesian liaison officers, upon request these helicopters can respond and be on station within 20 minutes.

2.3.3.6 Assumptions, Constraints, and Other Considerations

- Indonesia will allow the introduction of U.S. military into the region to perform MIO.
- The U.S. Area of Operations is currently a Threat Level II. Level II threats are defined as “Small tactical unit, unconventional forces, guerrillas, may include significant stand-off weapon threats.”⁹⁴
- Operation is conducted during the Indonesian rain season, therefore all unimproved road in the region are impassible by wheeled vehicles.
- Indonesia has limited the use of force for U.S. riverine forces. Use of force is allowed for self defense of the U.S. riverine force only and cannot conduct direct action/offensive operations. Use of force for self protection of the U.S. forces outside predetermined engagement zones must be coordinated with Indonesian forces.
- Limited airfields and airfield capacities in the region may restrict support to the U.S. Riverine forces. The only airfields in this region are in the cities of Telukmeranti and Kolomang and are small, unimproved facilities that can accommodate helicopter and small civilian aircraft only.
- Indonesian forces have the ability to communicate through various methods with U.S. forces in the region.
- Due to the weak Indonesian economy and rural area of operations, logistics support from host nation and region is limited.

- Medical care will be provided by host nation of Indonesia in the city of Kolomang, if required.
- All suspect personnel detained by the U.S. military operations will be turned over to the host nation of Indonesia within 90 minutes.

2.3.4 Basic Conduct of Maritime Interdiction Operations

A riverine squadron consisted of three detachments. Each detachment was comprised of 4 SURC's, and each SURC was manned by two alternating boat crews. A boat crew consisted of five personnel. There was an eight man boarding team assigned to each detachment which was comprised of U.S. and Indonesian personnel. Each MIO was performed by one detachment but on occasion was supplemented with additional craft as required by the situation. One SURC and boat crew was on standby for various contingencies that arose during the course of a mission. These contingencies included but were not limited to: transport of prisoners within the AO, relieving a disabled SURC on patrol, and rendering additional assistance as required to operational boats.

Each MIO mission was eight hours in duration after transit and turnover. The MIO was conducted at various, random sites within the AO, but was limited to a minimum of one nautical mile away from the basing alternative in order to minimize possible friendly fire and fratricide should an insurgent attack occur. Randomization of these search sites was an effort to provide the most force protection measures for these forces so that the insurgent forces could not foresee a pattern and mount an effective attack against these forces.

The forces employed the technique of beaching two SURC's, establishing a search site in which to conduct operations within, while one SURC serves as an escort for contacts of interest and the remaining SURC provides a sweeper/force protection function. Contacts of Interest were determined by two methods. The first method was any suspicious vessel was searched and the second was a random draw method. The detachment lead would determine which vessels to search through communications with each boat crew or intelligence reports from the TOC, UAV's, USV's, or from non-organic sensors. Once a vessel was considered a contact of interest, the escort SURC

would approach, and through the use of Indonesian interpreters onboard, would then escort the contact of interest to the search site and beach them. Once the contact of interest was beached, the escort SURC would fall back and provide protection for the search site and thwart any attempt of the contact of interest to escape. The beached contact of interest would then be searched by the boarding team, any suspicious personnel would be detained and weapons confiscated. If there were no weapons or suspicious personnel onboard, the contact of interest would be allowed to get underway. The average search time per vessel for the conduct of this operation was 10-15 minutes. Figure 18 depicts a generic search site set up for this operation.

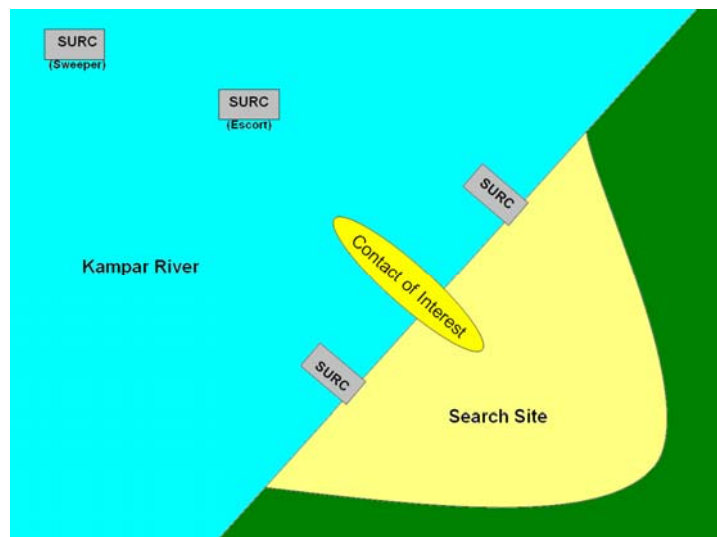

Figure 18. MIO Search Site

When suspicious personnel and or weapons were confiscated during a search, it was the detachment leaders' decision to either transport these personnel and materiel to the Indonesian outpost by using an on-station asset or call for the standby SURC to perform this task. This decision process also held for any casualty or unforeseen situation that occurred during the course of the mission. Due to the dense forestation of the region, if a casualty situation occurred, the injured personnel had to be transported back via boat to the base of operations in order to be picked up by the Indonesian helicopters for transport to the medical facilities in Kolomang.

If during the course of the mission the search site came under insurgent fire from landward position, it was the detachment leaders' decision on the appropriate course of

action. The search sites were previously coordinated with Indonesian forces; therefore self defense return fire was authorized. However, the decision on whether to hold ground and engage the enemy or withdraw from the site was the detachment leaders' responsibility.

2.3.4 Enemy Courses of Action (ECO A)

2.3.4.1 ECO A 1 Cease or Reroute Operations

With U.S. military forces conducting operations upon the Kampar River, the insurgents may cease operations in this region, or cease operations upon the Kampar River and reroute their shipments to Telukmeranti via landward routes. This course of action would slow the transport of insurgent weapons and materiel into the region due to the increased time required to transport this materiel over land during the rainy season. This materiel would have to be carried in by personnel on foot due to the impassable nature of the roads and terrain during this time.

2.3.4.2 ECO A 2 Employ Decoys and Harassment

Through observations of U.S. operations upon the Kampar River, the insurgents may find alternatives that may be feasible in order to try to sneak their weapons and materiel's past the U.S. Riverine Forces. Through the use of decoy vessels and just playing the odds of getting randomly searched by U.S. forces may be acceptable risks that the insurgents are willing to accept in order to continue their operations in Telukmeranti. Harassment of U.S. forces may be an acceptable risk the insurgents are willing to take. Through the use of insurgent land and water assets, engaging the U.S. forces in small skirmishes upon the river and search sites may draw attention from vessels upon the river and allow these vessels through the area relatively unnoticed.

2.3.4.3 ECO A 3 Engagement of Forces

The insurgents may assess that direct attacks upon the U.S. forces may be effective at causing a large number of U.S. casualties and damaging equipment. These attacks may significantly degrade the Riverine Forces abilities at conducting MIO upon

the Kampar River and due to strong U.S. public opinion may cause the U.S. to withdraw from the region.

⁶⁸ U.S. Department of Defense, *Joint Publication 5-0: Joint Operation Planning*, 26 December 2006 (Washington, DC: GPO, 2006), C-5.

⁶⁹ Dennis. M. Buede, *Engineering Design of Systems: Models and Methods* (New York: John Wiley & Sons, 2000), 139.

⁷⁰ Dennis. M. Buede, *Engineering Design of Systems: Models and Methods* (New York: John Wiley & Sons, 2000), 140.

⁷¹ Naval Expeditionary Combat Command, *U. S. Navy Riverine Group, Concept of Operations*, 28 September 2006 (Little Creek, VA: GPO, 2006), 17.

⁷² Naval Expeditionary Combat Command, *U. S. Navy Riverine Group, Concept of Operations*, 28 September 2006 (Little Creek, VA: GPO, 2006), 21.

⁷³ U.S. Department of Defense, *Joint Publication 5-0: Joint Operation Planning*, 26 December 2006 (Washington, DC: GPO, 2006), 4-34.

⁷⁴ U.S. Department of Defense, *Joint Publication 5-0: Joint Operation Planning*, 26 December 2006 (Washington, DC: GPO, 2006), 4-32.

⁷⁵ U.S. Department of Defense, *Joint Publication 5-0: Joint Operation Planning*, 26 December 2006 (Washington, DC: GPO, 2006), 4 -32 – 4 -36.

⁷⁶ U.S. Naval Surface Warfare Center, Dahlgren Division, *Operational Logistics: Navy Expeditionary Small Boat Units Draft* (Dahlgren, VA: GPO, 2007), 11.

⁷⁷ U.S. Department of Defense, *Joint Publication 5-0: Joint Operation Planning*, 26 December 2006 (Washington, DC: GPO, 2006), 1-5.

⁷⁸ U.S. Department of Defense, *Joint Publication 3-35: Joint Deployment and Redeployment Operations*, 7 September 1999 (Washington, DC: GPO, 1999), 3-15.

⁷⁹ U.S. Department of Defense, *Joint Publication 3-35: Joint Deployment and Redeployment Operations*, 7 September 1999 (Washington, DC: GPO, 1999), 1-15.

⁸⁰ U.S. Department of Defense, *Joint Publication 3-35: Joint Deployment and Redeployment Operations*, 7 September 1999 (Washington, DC: GPO, 1999), 3-9.

⁸¹ U.S. Department of Defense, *Joint Publication 3-35: Joint Deployment and Redeployment Operations*, 7 September 1999 (Washington, DC: GPO, 1999), 3-9.

⁸² Center for Naval Analyses, *Renewal of Navy's Riverine Capability: Resource Implications for Combat Support/Combat Service Support and TSC*, January 2006 (Alexandria, VA: GPO, 2006), 27.

⁸³ Center for Naval Analyses, *Renewal of Navy's Riverine Capability: Resource Implications for Combat Support/Combat Service Support and TSC*, January 2006 (Alexandria, VA: GPO, 2006), 30.

⁸⁴ U.S. Department of Defense, *Joint Publication 3-35: Joint Deployment and Redeployment Operations*, 7 September 1999 (Washington, DC: GPO, 1999), 3-12.

⁸⁵ U.S. Department of Defense, *Joint Publication 3-02: Joint Doctrine for Amphibious Operations*, 19 September 2001 (Washington, DC: GPO, 2001), 15-2.

⁸⁶ U.S. Department of Defense, *Joint Publication 3-35: Joint Deployment and Redeployment Operations*, 7 September 1999 (Washington, DC: GPO, 1999), 1-16.

⁸⁷ U.S. Department of Defense, *Joint Publication 1-02: Department of Defense Dictionary of Military and Associated Terms*, 1 March 2007 (Washington, DC: GPO, 12 April 2007), 187.

⁸⁸ U.S. Department of Defense, *Joint Publication 5-0: Joint Operation Planning*, 26 December 2006 (Washington, DC: GPO, 2006), 1-17.

⁸⁹ Naval Expeditionary Combat Command, *U. S. Navy Riverine Group, Concept of Operations*, 28 September 2006 (Little Creek, VA: GPO, 2006), 11.

⁹⁰ Naval Expeditionary Combat Command, *U. S. Navy Riverine Group, Concept of Operations*, 28 September 2006 (Little Creek, VA: GPO, 2006), 11.

⁹¹ Naval Expeditionary Combat Command, *U. S. Navy Riverine Group, Concept of Operations*, 28 September 2006 (Little Creek, VA: GPO, 2006), 12.

⁹² U.S. Department of Defense, *Joint Publication 3-35: Joint Deployment and Redeployment Operations*, 7 September 1999 (Washington, DC: GPO, 1999), 1-17, 1-18.

⁹³ U.S. Department of Defense, *Joint Publication 3-35: Joint Deployment and Redeployment Operations*, 7 September 1999 (Washington, DC: GPO, 1999), 1-18.

⁹⁴ U.S. Naval Surface Warfare Center, Dahlgren Division, *Operational Logistics: Navy Expeditionary Small Boat Units Draft* (Dahlgren, VA: GPO, 2007), 11.

3. FUNCTIONAL ARCHITECTURE

3.1 FUNCTIONAL ARCHITECTURE COMPONENTS AND PURPOSE

“Architecture is the scheme of arrangements of the components of a system, and it describes features that are repeated throughout the design and explains the relationship among the system’s parts.”⁹⁵ In system engineering the functional architecture describes what the system must do, its interfaces, and flows. The RST developed the functional architecture in parallel with the physical architecture for the study. The RST began the functional analysis by performing stakeholder analysis, which involved identifying and interviewing pertinent stakeholder. After conducting stakeholder analysis, the RST developed system decompositions, functional flow block diagrams, input/output models and objective hierarchies for their functional architecture.

System decomposition is technique used to better understand a system by breaking its attributes into smaller blocks. A system can be decomposed by its functions, states, components and hierarchical structure. Functions simply describe what the system is intended to do by taking a particular set of inputs and producing a set of outputs. States utilize a collection of variables to identify system condition. Components are a logical break-down of the system’s parts; they are further categorized by structure, flow and operation. Finally, hierarchical structure considers the physical and functional relationship between the system’s components.⁹⁶

A functional flow block diagram (FFBD) is used to illustrate a system in its functional terms. A FFBD consists of functional blocks connected by and/or connectors and arrows to depict the system’s functional flow. Using a hierarchical approach the FFBD reflects activities as they occur during the system’s life cycle. The FFBD should cover all applicable functions and inherent sequences. Functional blocks in the FFBD follow a progressive numbering scheme that preserves proper sequence and continuity.⁹⁷ The FFBD is a powerful tool in functional analysis execution.

The input/output model is a very useful apparatus for analyzing the needs and constraints of a system. The input/output model specifically describes how inputs

(controllable and uncontrollable) are put through a system process and outputs (intended and by-products) are derived. Controllable inputs are the inputs that can be controlled such as resources, procedures, or organization structure. Uncontrollable inputs are rarely controlled and include weather, demand, and governmental interference. Intended outputs are the desired products of the system and should be maximized. They are the primary reason for having the system in the first place. By-products are usually unintended and can have positive or negative effects. In most cases by-products, such as pollution, have a negative impact and should be minimized. The input/output model is beneficial in defining a system's boundaries and boundary conditions.⁹⁸

The objectives hierarchy is a top-down process that starts with the client's ends and creates a logical progression down through ways and means to metrics. Effective need, functions, sub-functions, objectives and evaluation measures comprise the objectives hierarchy. The client's effective need is discovered after conducting stakeholder analysis. Functions and subsequent sub-functions are processes that transform inputs into outputs that are mutual exclusive and collectively exhaustive. Objectives refer to the system's goals and those goals are measured by evaluation measures. Good evaluation measures, MOP's and MOE's, are measurable, quantifiable, and directly related to the objective.⁹⁹ The objectives hierarchy takes considerable effort, but when done correctly it yields powerful results.

3.1.1 Initial Problem Statement

System engineering is an organized approach to complex problem solving. It combines engineering know how with sound business judgment to create viable solutions. The first step in system engineering is identifying the stakeholders' primitive need, which is a want or desire based on a real or perceived shortfall.¹⁰⁰ From the Wayne E Meyer's Institute Integrated Project Tasking, "Collaborate with the Naval Expeditionary Combat Command (NECC) to design a system of systems for performing emerging Navy missions associated with coalition operations in littoral and riverine environments."¹⁰¹, the RST constructed an initial problem statement: "Define, analyze, and recommend alternatives that increase sustainability and connectivity of cooperative,

adaptive force packages in the riparian environment utilizing technologies currently in use or available for use by 2012.” The initial problem statement served as a starting point to decompose the riverine sustainment system.

3.2 STAKEHOLDER ANALYSIS

3.2.1 Stakeholders

The RST visited several stakeholders in order to gain insight and determine which issues were most relevant in order to focus the project and develop alternatives which would be beneficial to these stakeholders. Figure 19 depicts the RST stakeholder locations.



Figure 19. RST Stakeholder Map

The Primary Stakeholders of the SEA-11 Riverine Sustainment project were NECC, River Group One (RIVGRU ONE), and River Squadron One. Other stakeholders that had valuable insights into this project and would benefit from this study are: SBT-22, NAVSCIATT, LOGSU-1, NCW-1, and NSWC. These primary and secondary stakeholders missions, operations, and organizations all have common aspects that were analyzed in this study.

3.2.2 Stakeholder Input

Stakeholder input and feedback are an essential part of the systems engineering and design process in that stakeholder needs are developed into operational requirements and ensures that the developed outputs of the alternative designs are validated by the stakeholder feedback.¹⁰² Once the scope of the project was focused on riverine operations, the RST made several trips to discuss relevant issues and RST goals in order to attain stakeholder buy-in and inputs for developing the project. This initial contact and input from the stakeholders was invaluable. The largest takeaway from these discussions was that the NECC and River Group One had been focused on taking over the Marine Corps Small Combatant Craft Company's role in Iraq, primarily the guarding of the Haditha Dam in Baghdad. This narrow focus was due to the short amount of time that the NECC and River Group One had to stand up, develop operational capabilities and deploy forces within a year's time. The full capability of the riverine forces was currently in development and there were many aspects to conducting the myriad of operations that these forces were tasked with that had not been explored in depth.

3.2.3 Core Documentation

As no member of the RST had operational knowledge of the riverine squadrons, numerous core documents were reviewed to gain valuable insights and knowledge about riverine operations and force structure. For historical references the RST reviewed The Center for Naval Analysis' *Renewal of Navy's Riverine Force Capability: A Preliminary Examination of the Past, Current, and Future Capabilities*, the Marine Corps Center for Lessons Learned *Small Craft Company's Deployment in Support of Operational Iraqi Freedom II: A summary of lessons and Observations*, the Naval Historical Divisions *The U.S. Navy's Operations on Inland Waters*, and *Brown Water, Black Berets* by LCDR Thomas J. Cutler. The RST was able to determine capability gaps from these documents and increase the teams' knowledge of the problems with riverine operations and lessons learned from past operations. In order to understand the current riverine force structure and operations the RST studied the U.S. Navy Riverine Force Concept of Operations. Reviewing and understanding these core documents allowed the RST to explore

capability gaps within the current riverine force structure and apply lessons learned from past experiences in developing feasible alternatives for filling these gaps.

3.3 SYSTEM DECOMPOSITION

A system is defined as “an assemblage or combination of elements or parts forming a complex or unitary whole.”¹⁰³ The purpose of system decomposition is to analyze the current system and its elements in order to have an increased understanding of the system. Systems are comprised of functions, components, hierarchical structure, and states.¹⁰⁴ After researching the history of riverine warfare and present day concepts, RST analyzed the systems of the existing RF supply, command and control, repair, and force protection.

A function is a definite, purposeful action that a system must accomplish to achieve one of the system’s objectives.¹⁰⁵ The components affect and influence the system. There are structural, operating, and flow components. Structural components are the physical aspects of the system, operating components are the entities required to perform system processing, and flow components are the material, energy, or information being altered.¹⁰⁶ The hierarchical structure, which is broken down to super system, lateral system, and sub system, helps show where the functions and components exist. Finally, the states of the system are the different variables used to reflect the condition of the system at a specific time.¹⁰⁷

3.3.1 Supply Group

The decomposition of riverine supply, based on the U.S. Navy Riverine Force Concept of Operations prepared by NECC, is shown in Figure 20.

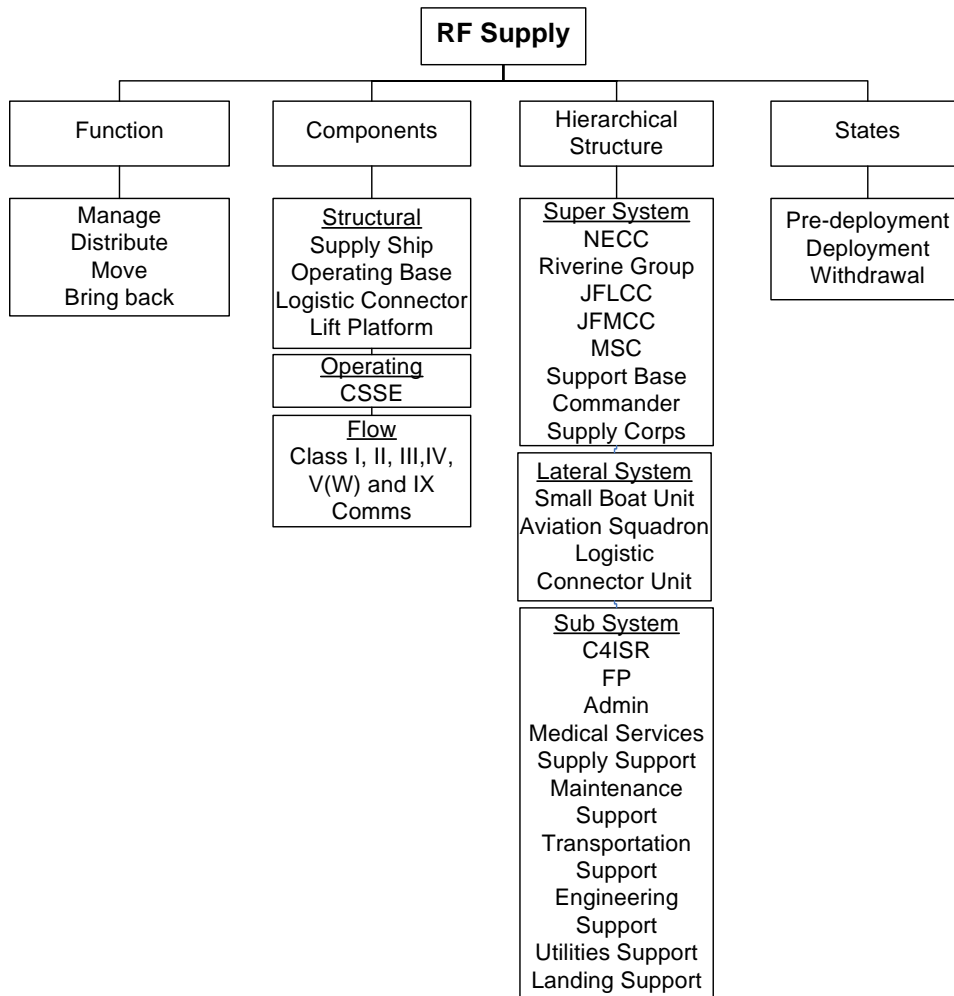

Figure 20. Riverine Force Decomposition

3.3.1.1 Functions

The functions of supply are to manage, distribute, move, and to bring back. Supplies are first controlled and organized. After a request has been made, the supplies are prepared for shipment. Then, supplies are transported to the destination of the requestor. Certain unused materials are returned supply for redistribution.

3.3.1.2 Components

Structural components comprise the physical aspects of RF Supply. These include the supply ship, operating base, and logistic connector. The operating component is the Combat Service Support Element (CSSE), which is the entity that provides many of

the logistic services and support. Flow components include Supply Classes I, II, III, IV, V (W), and IX that are distributed to the RF.¹⁰⁸

3.3.1.3 Hierarchical Structure

Super systems for RF Supply are the top-level organizations. These include NECC, Support Base Commander, and Supply Corps. Lateral systems indirectly support or perform the functions of the RF Supply. Lateral systems include the small boat unit, logistic connectors, and CSSE. Sub systems directly support the RF Supply. Sub-systems include C4ISR, FP, supply support, maintenance support, utilities support, and landing support.¹⁰⁹

3.3.1.4 States

States are the operational phases that reflect the condition of the RF logistics. The different phases are pre-deployment, deployment, and withdrawal. The RF assembles the allotted initial pack out supplies in the pre-deployment phase. During the deployment phase, the RF is re-supplied through logistic channels in the area of operations. The RF during the withdrawal phase packs up and transports the un-used supplies out of the current operational area.

3.3.2 Repair Group

Currently, many aspects of riverine maintenance are conducted in an informal manner through the use of contractors. In order to formalize this process, the RST began with a systems decomposition of the current system, detailed in Figure 21.

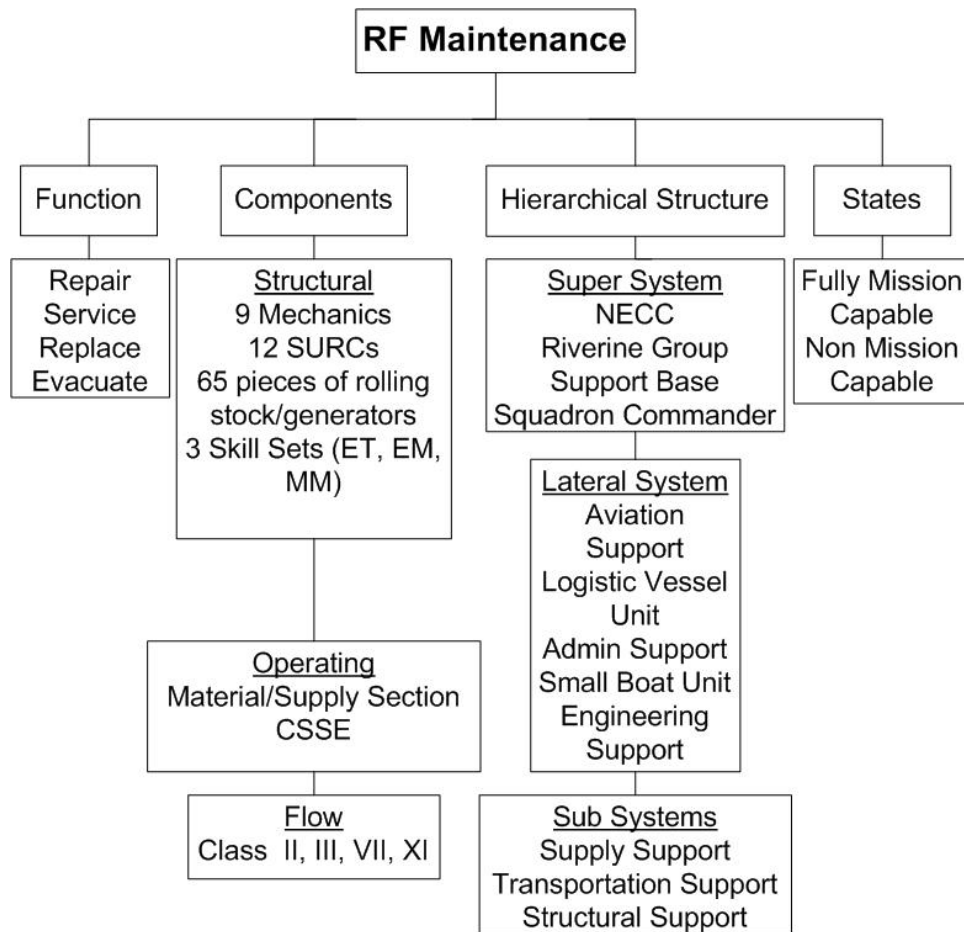

Figure 21. Maintenance System Decomposition

3.3.2.1 Functions

The functions of the maintenance system were derived from U.S. Army¹¹⁰ and Marine Corps¹¹¹ maintenance doctrine, and were tailored to fit our concept of operations. In order to conduct maintenance in a Level II threat environment, this study determined that the following maintenance functions had to be accomplished: Service, Repair, Replace, and Evacuate. Service was defined as the process of identifying faults through preventive maintenance in order to maintain the operational readiness of the boat. Repair represented the act of fixing a damaged boat in this study. Replace allowed for the substitution of serviceable parts or end items for those that are damaged, and evacuation represented the removal of an end item out of the area of operation for depot level maintenance.

3.3.2.2 Components

Components represented the physical constructs of the riverine maintenance system and are split into three categories: structural, operating, and flow. Structural represented the physical make up of the system which included the nine mechanics and 12 SURC craft. Operating represented the entities required to carry out the maintenance function which included the maintenance/supply section as a subordinate part of the CSSE, but also required support from other CSSE's in order to function. Flow represented the maintenance system's interaction with other elements within the logistics system and was comprised of Class II and Class XI parts, Class III POL, and Class VII major end items.

3.3.2.3 Hierarchical Structure

Within the hierarchical structure, super systems for RF maintenance system were the top-level organizations. These included the NECC, the Riverine Group, Support Base, and Squadron Commander. Lateral systems provided indirect support to the maintenance system, such as the logistic vessel unit, and engineering support. Sub systems directly supported the maintenance system through include supply support, transportation support, and structural support.

3.3.2.4 States

States were the operational phases that reflected the condition of parts and equipment, as they flowed through the maintenance system. In this study, the 12 SURC's and the 65 pieces of rolling gear were bounded such that they were either fully mission capable (FMC) or non-mission capable (NMC). If a piece of equipment was NMC, it was categorized into the following sub states: awaiting parts, awaiting repair, being serviced, or evacuated for depot level maintenance.

3.3.3 Force Protection Group

The systems decomposition model for the Force Protection System (FPS) (Figure 22) represented an overview of the functions, physical composition, and relationship of

the FPS to other systems. The model improved the RST's understanding of how the FPS operates and the assets available to the FPS.

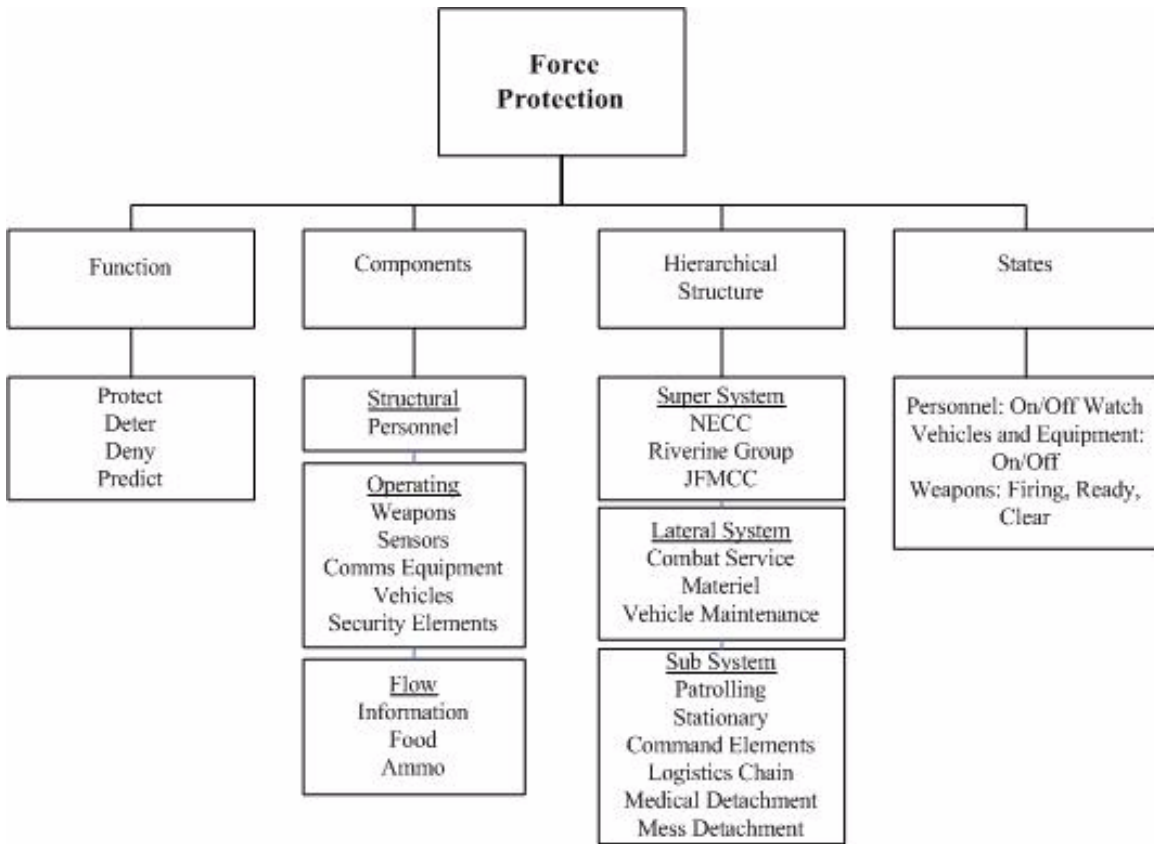

Figure 22. FP Decomposition

3.3.3.1 Functions

The overarching function for the Force Protection System (FPS) of the riverine FOB is to protect the RF, and other detachments, while operating within and in close proximity to the FOB. The functions that comprise protection are deterring, denying, and predicting the threat. Deterrence is defined as “the prevention from action by fear of the consequences. Deterrence is a state of mind brought about by the existence of a credible threat of unacceptable counteraction.”¹¹² In the context of protecting the FOB, the FPS hopes to deter civilians from entering the immediate perimeter of the FOB to decrease the amount of contacts, and of course, dissuade attacks by hostile forces. A denial measure is defined as “to withhold the possession, use, or enjoyment of.”¹¹³ For protection of the FOB, the FPS is denying enemy forces a successful attack by destroying

enemy personnel, weapons, and the means to assemble personnel and weapons. Predicting the threat is the ability of the FPS to have the correct force for the correct threat, primarily through the use of intelligence. The addition and use of intelligence for force protection is what separates force protection from self defense,¹¹⁴ creating a more proactive, efficient force.

3.3.3.2 Components

The structural component of the FPS is the personnel the RF would assign to security, as well as other security detachments provided by the NECC. The operational component consists of the weapons, sensors, communication equipment, vehicles, and various security elements required of the FPS to accomplish the mission. The security elements that are generally required in security are the command element, patrolling elements, and stationary or guard elements. The FPS flow component enables interaction with other parts of the RF. The entities that flow through the FPS are information and logistics. Information could take the form of communications and other data to provide situational awareness for the FPS. Logistics could take the form of food, ammunition, fuel, and other necessities the FPS requires to maintain operations.

3.3.3.3 Hierarchical Structure

The FPS of the RF is considered part of the support element.¹¹⁵ As such, the super system of the FPS consists of the RF, NECC, and the JFMCC. The lateral systems of the FPS include the other members of the RF support element such as: combat service, materiel, and vehicle maintenance. Given the coalition environment the RF can operate in, various lateral systems include other FPS's provided by coalition partners. The subsystems of the FPS include patrolling, stationary, and command elements and the equipment utilized by the FPS. The subsystems also include the logistics chain, medical detachment, and messing detachment that contribute to the FPS fulfilling its mission.

3.3.3.4 States

The states of the FPS are the conditions the components of the FPS can be in as they pertain to FP. For the security personnel, these states include on and off of watch. The vehicles and electronics equipment that comprises the FPS, such as the sensors and communications gear, can be on or off. Finally, the weapons used in the FPS can be in the firing, ready, or clear mode. Firing mode is when the weapon is engaging the enemy. The ready mode is when the weapon has ammunition loaded and, but has some type of safety mechanism that must be turned off to fire. The clear mode is the weapon has no ammunition in the chamber and is unloaded with the safety on.

3.4 INPUT-OUTPUT MODEL

An Input-Output model is a very useful tool for “thinking about the needs and constraints” of a proposed system.¹¹⁶ Each group developed an input-output model. When developing the model, each group analyzed which inputs are necessary to achieve the desired outputs. Inputs are classified as either controllable or uncontrollable. Controllable inputs can be classified as physical, human, informational, and economic. Uncontrollable inputs can be classified as environmental characteristics and existing conditions.¹¹⁷ In essence, controlled inputs are elements that can be manipulated and changed while uncontrollable inputs cannot. These inputs in the different systems resulted in intended outputs and by-products. Intended outputs justify the existence of the system, while by-products often suggest constraints that the new system must meet.¹¹⁸

3.4.1 Supply Group

The input-output model for RF Supply is shown in Figure 23.

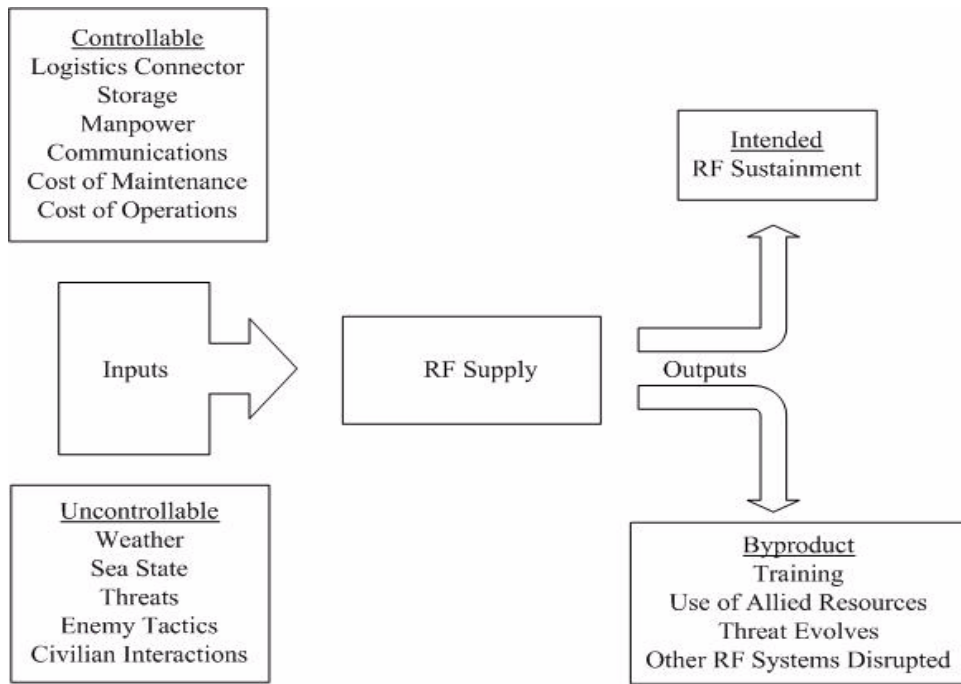

Figure 23. RF Supply Input-Output Model

The controllable inputs of RF Supply include the logistic connector, storage, manpower, communications, and cost of maintenance and operations. Supply of the RF up river will be accomplished by the logistic connectors. Logistic connectors may be one or more vessels or aircrafts that transfer the supplies to the RF. Once the supplies are delivered to the operating base, they must be stored in order to be readily available for the RF. Whether storage is on land or ship, the storage area must be an optimal size. Depending on supply requirements and the logistic connectors used, there are certain amounts of manpower required to distribute the supplies to the RF. Adequate lines of communication must also be established between the RF, operating base, and supply ship. The entire operation will require certain costs. The costs include time and money to utilize the logistic connectors as well as maintain them.

The uncontrollable inputs of RF Supply include weather, sea state, threats, enemy tactics, and civilian interactions. Sea state is “a scale that categorizes the force of

progressively higher seas by wave height.”¹¹⁹ Weather and sea state can affect how often the RF will be re-supplied. In extreme weather conditions, the RF may go several days without re-supply. In sea state zero, re-supplying the RF may be easier. Threats and enemy tactics can also affect re-supply of the RF. The enemy can attempt to disrupt the flow of supplies to the RF, and enemy tactics will adapt and change throughout the duration of an operation. Finally, civilian interactions along the river will affect the RF and logistic connectors due to varying traffic density and the enemies’ ability to blend in with the local civilian population.

The intended output of RF Supply is sustainment. Sustainment can be achieved by performing timely re-supply of the RF. Supplying the RF with adequate resources, by providing the proper logistic connectors and storage facilities, enables it to be operational for as long as possible.

Byproducts of RF logistics include unit training, the use of Allied resources, evolving threat, and disrupting other RF systems. While performing their missions, the RF and personnel re-supplying them will gain experience. Their experience will enable them to be more proficient in future operations. A negative byproduct, however, is the use of Allied resources. Requesting the use of certain vessels or aircrafts means that they cannot be used in other parts of the world. Using certain resources, such as manpower and communication assets, may also disrupt other operations that may need the same resources. Finally, the threat may also learn from the actions of the RF and find other ways to disrupt the flow of supplies.

3.4.2 Repair Group

The input-output matrix “is a useful device for thinking about the needs and constraints for a proposed system.”¹²⁰ Figure 24 represents the input output model for the RF maintenance system.

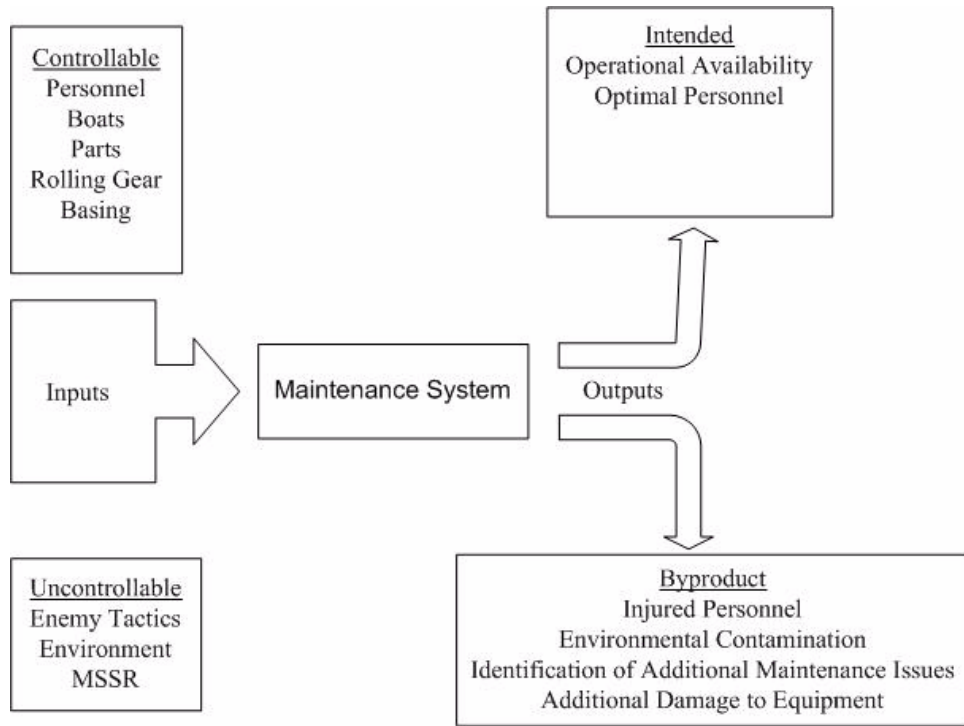

Figure 24. Repair Input-Output Model

After examining the U.S. Army and Marine Corps maintenance systems, the RST developed the following controllable inputs: personnel, parts on-hand, boats, and rolling-gear. Personnel represented the nine highly-qualified maintenance technicians in each squadron’s maintenance section. For this study, there were 12 SURC patrol crafts and 65 pieces of rolling-gear that were to be maintained by the RF maintenance section. Parts on-hand consisted of service items that were to be maintained by the RF in their pack-up kit (PUK). Parts that were mission critical, or had a high failure rate, were placed in the PUK. However, any effort to return an item to serviceable condition was met with two key environmental challenges: geographic location and weather. Furthermore, supporting operations from a MOB introduced new challenges in repairs rendered while afloat. Simple engine changes conducted ashore at the FOB became major logistical challenges at the MOB. Uncontrollable inputs included operational availability, which was calculated as:

$$A_o = \frac{MTBF}{MTBF + MCRT + MPRT + MSRT}$$

Operational Availability¹²¹

In this study, Operational Availability (A_o) was defined as “the probability that a system or product will be available to perform its intended mission or function when called upon to so at any point in time.”¹²² MTBF was the mean time between maintenance actions (including both preventive and corrective maintenance). What has been referred to as the mean time to repair (MTTR) was broken down into the mean time to perform corrective maintenance (MCRT) and the mean time to perform preventive maintenance (MPRT). Mean supply response team (MSRT) was based upon the RST scenario parameters which varied from 24 to 144 hours. Mean administrative delay time (MADT) was built into the MCRT and MPRT functions within model and is further discussed in Chapter 5. It is important to note that these maintenance actions did not occur in a vacuum, as enemy tactics influenced the number of maintenance personnel available to perform maintenance. Furthermore, enemy actions and weather limited the use of supply routes, which hindered the RF’s ability to receive and move replacement parts in a timely manner.

The intended outputs were increased operational readiness rates due to lower MTTR rates, optimal manning and optimal maintenance facilities. Specifically, lower MTTR rates led to higher availability rates. Facing a multitude of threats, the RF required a highly effective maintenance system that minimized MTTR times with the optimum mix of personnel. To accomplish this optimization, this study “searched the cost/availability trade space to find the lowest cost and highest availability inventory solution.”¹²³ The by-products of this model were injured personnel, environmental contamination from spills, the identification of additional maintenance issues, and additional damage resulting from the repair. Maintenance is an inherently hazardous operation, as performing repairs on SURC’s and rolling-gear can be both hazardous to personnel and the surrounding environment. For these reasons, every measure must be implemented to safeguard RF personnel and the habitat they are operating in. Occasionally, repair parts and tools are damaged in the performance of preventive and corrective maintenance. Also, during maintenance actions, additional equipment defects are discovered and rectified prior to major system failures.

3.4.3 Force Protection Group

The input-output model for the RF Force Protection System (FPS) is shown in Figure 25.

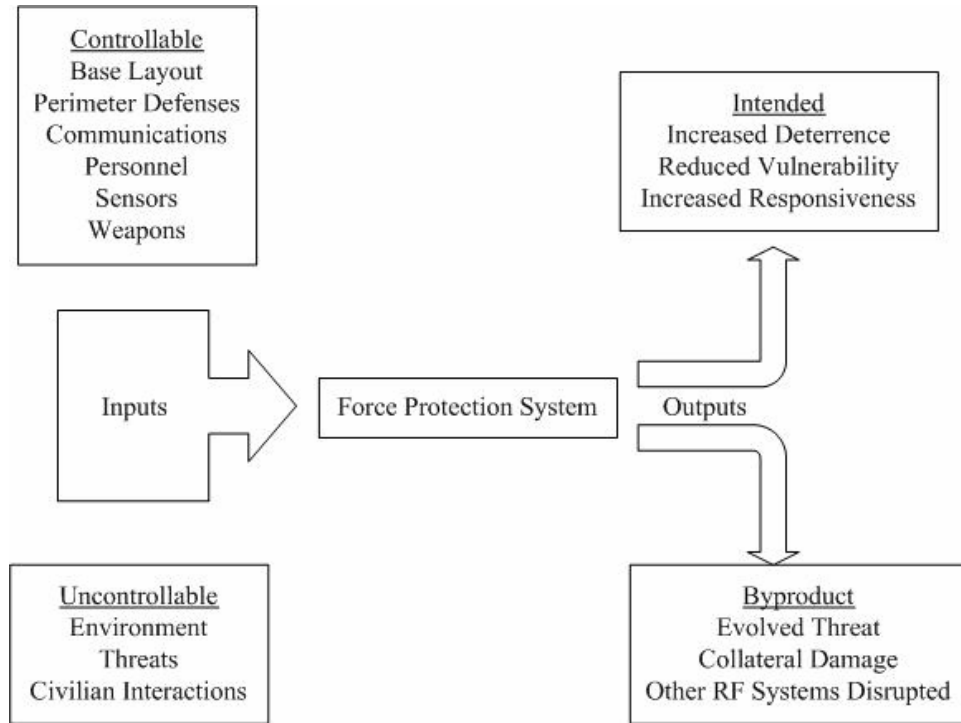

Figure 25. Force Protection System Input Output Model

The controllable inputs of the RF FPS include the base layout, perimeter defenses, communications, personnel, sensors, weapons, and barriers. The base layout consists of base facilities and locations such as troop housing, mess halls, fuel storage, and showering facilities. For force protection, base layout is an important consideration so that high value or volatile facilities are not overly vulnerable. Perimeter defenses include the types and locations of the barriers and bunkers and may include the locations of sensors, signs, and other detection systems. When the RF is forward based, the perimeter defenses are layered in a variety of ways to optimize detection of contacts and provide effective security measures from possible enemy assaults. Communications consists of the facilities, procedures, and equipment used for communications by the security forces.

All of these communication elements are controlled to ensure expedient information flow while maintaining security. The number of personnel assigned to the FPS is also controlled to maintain the highest protection posture while providing adequate personnel rest. The types of sensors and sensor layout will be controlled to ensure the greatest capability given the operating environment. Finally, weapon types will be controlled in their usage and placement to supply the necessary firepower and effective fields of fire for the envisioned threat while maintaining high states of readiness.

The uncontrollable inputs include the environment, threats, and civilian interactions. The weather and water level of the river make up the environment. Threat comprises the size and type of enemy forces as well as enemy weapons, vehicles, and tactics. For this study, the FPS faced a Threat Level II threat that included at most 150 people with AK-47's, crew served weapons, and improvised explosive devices. The final uncontrollable input is the civilian interactions with the FPS. Civilians can positively provide indications of threats and negatively disguise threats based on traffic and activity near the RF.

The intended outputs of the FPS are increased deterrence, reduced vulnerability, and increased responsiveness. Increased deterrence is desired against enemies to prevent attack, but also to prevent civilians from entering areas requiring a response by the FPS. Increased deterrence is difficult to achieve for the small RF footprint desired because in its nature increasing deterrence requires a demonstration of capability and force size. The FPS must also demonstrate capabilities without revealing relevant tactics to enemy forces. Reduced vulnerability consists of a reduction in the possibility of a security breach, damage to the basing facility and/or injury to personnel should an attack occur. Increased responsiveness, essentially the ability to respond to enemy threats rapidly, is critical in successfully defending the base against enemy attacks and other events requiring an increase in force protection posture.

The by-products of the FPS are an evolved threat, collateral damage, and other RF systems disrupted. An evolved threat defined as the enemy has discovered sufficient means to bypass or overcome the FPS. This could be in the weapons and tactics the enemy employs against the RF. If the enemy evolves and becomes more capable, more

effective enemy attacks may place the RF and its coalition partners at a greater risk. Collateral damage could take the form of injured civilians or damaged equipment as a result of the FPS’s actions. Finally, other RF systems, such as maintenance or logistics, could be disrupted because of the operations being conducted by the FPS. For example, if the FPS results in the slowing of traffic around the FOB, or creates many false alarms, the movement of supplies into the FOB could potentially decrease.

3.5 FUNCTIONAL HIERARCHY

The completion of System Decomposition and the Input-Output model lead into defining the problem in terms of functions performed by the RF. RST bounded the problem by using a MIO scenario on the Kampar River in Indonesia. By defining the exact scenario, a list of global functions could be developed that focused on areas for the RST to research. This “decomposition, often referred to as top-down structuring, begins with the top level system function and partitions that function into several sub-functions.”¹²⁴ The RST composed the functional hierarchy into four global functions: engage, deploy, C4ISR operations, and sustainment as shown in Figure 26. Each one of these global functions was used as insight to determine potential solutions in terms of hardware, manpower, data, or software. Then each global function was decomposed into sub-functions to scope and further define the problem. Each function was defined using standard military definitions from Joint Pub 1-02.

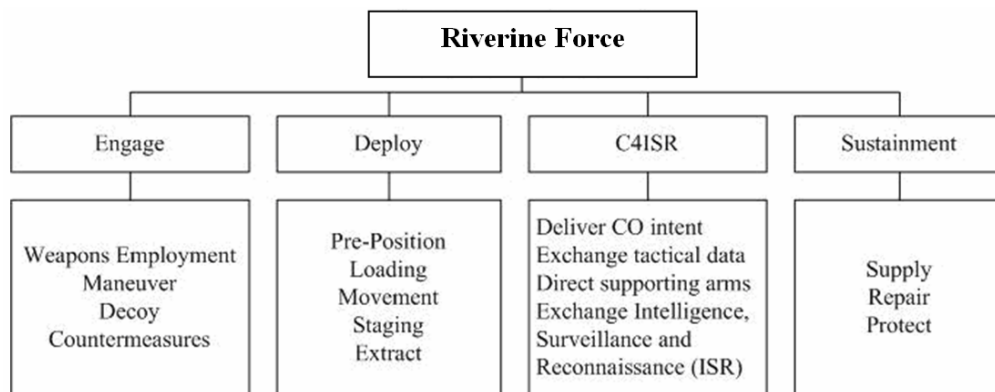

Figure 26. Riverine Force Functional Hierarchy

Engage is to bring the enemy under fire.¹²⁵ A series of related major operations aimed at achieving strategic and operational objectives within a given time and space.¹²⁶

Sub-functions of engage include:

- Weapons Employment
- Maneuver
- Decoy
- Countermeasures

Deploy is the relocation of forces and materiel to desired operational areas. Deployment encompasses all activities from origin or home station through destination, specifically including intra-continental U.S., inter-theater, and intra-theater movement legs, staging, and holding areas.¹²⁷ Sub-functions of deploy include:

- Pre-Position
- Loading
- Movement
- Staging
- Extract

C4ISR is the exercise of authority and direction by a designated commander over assigned and attached forces in accomplishment of the mission. C4ISR is performed through an arrangement of personnel, equipment, communications, facilities, and procedures employed by a commander in planning, directing, coordinating, and controlling forces and operations in the accomplishment of the mission.¹²⁸ Sub-Functions of C4ISR include:

- Deliver the commander's intent
- Exchange tactical data
- Direct supporting arms
- Exchange Intelligence, Surveillance and Reconnaissance (ISR)

Sustainment is the provision of logistics and personnel services required to maintain and prolong operations until successful mission accomplishment.¹²⁹ Sub-functions of sustain include:

- Supply
- Repair
- Protect

Interaction with stakeholders and the needs analysis showed a capabilities gap in two major functions. The first gap identified was the communication interaction with allied forces. A common operating picture that would be able to connect older legacy technology with newer technology employed by the RF was needed in order to effectively use host nation forces in current RF missions.

The second gap identified is an assumed lack of support for creating large basing options in host countries. Therefore a logistic system needs to be developed to sustain a small operating force in any terrain that is located upstream away from the littorals, with waterways being the primary mode of transportation.

The need to improve the supply chain and develop a solution to replace the “Iron Mountain” approach became the research focus after system decomposition and initial stakeholder feedback. With this need in mind, the functions of sustain and C4ISR were analyzed by looking at the supply, repair, communication, and protection functional hierarchies.

3.5.1 Supply Group

The supply functional hierarchy shown in Figure 27 illustrates four major sub-functions. The supply sub-functions are: management, maintain, movement, and bringing back of supplies. While management is more of an enabler than a true function, the RST included the function at this level of the hierarchy because of its significance. However, the RST primary focus was on the sub-functions of maintain, movement, and bring back to determine mechanisms that would increase overall performance of the RF. The function of management is further explored in Appendix F.

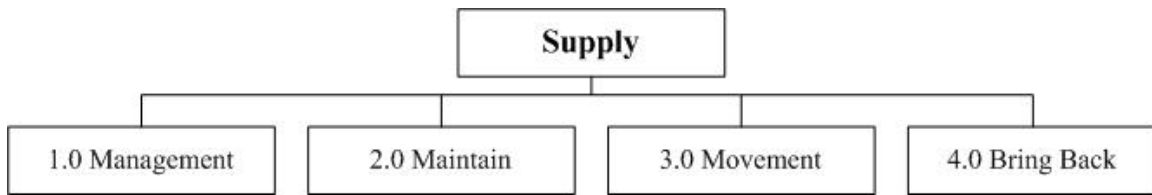

Figure 27. Supply Functional Hierarchy

3.5.1.1 Maintain

Maintain is the operational physical process synchronizing elements of the logistic system to deliver the “right thing” to the “right place” at the “right time” in order to support the operational commander.¹³⁰ Sub-functions of maintain are shown in Figure 28.

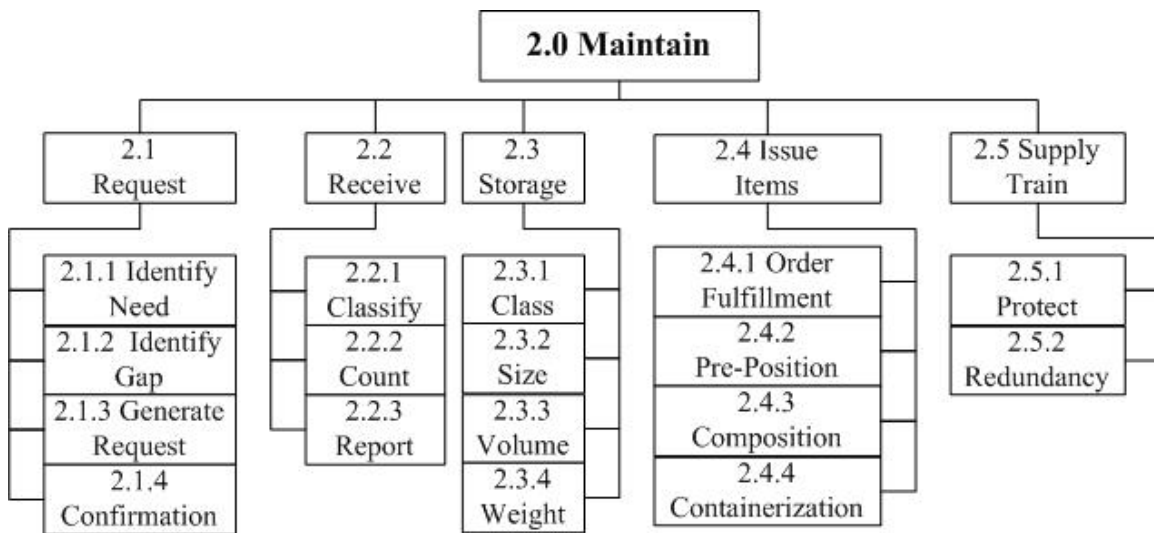

Figure 28. Maintain Functional Hierarchy

Request is the function of asking to fill a need, by first identifying the gap between actual and desired amounts, generating a request to submit through proper channels, and ensuring confirmation of request and arrival of materiel.

- Identify Need – act of defining criterion that requires supply personnel to react in order to ensure that supply levels remain able to accomplish the mission.¹³¹
- Identify Gap – act of recognizing minimum supply requirements and comparing to actual status in order to obtain minimum specified overlap.¹³²
- Generate Request – perform the physical act of notifying the supply chain via message or voice.
- Confirmation – perform the physical act of ensuring request is received and confirming arrival of materiel.

Receive is the function of classifying, accounting, and reporting of personnel or materiel from the intra-theater deployment phase to a sea, air, or surface transportation point of debarkation to the marshalling area.¹³³

- Classify – act of recognizing composition of received supplies and labeling according to Department of Defense standard ten classes of supplies.¹³⁴
- Count – accurate counting of materiel received.
- Report – transmission of data or a report from the originating terminal to the end receiver to acknowledge receipt and quantity of supplies.¹³⁵

Storage is the act of placing materiel onboard a vessel or in a facility. Storage relates to the act of securing those items stored in regard to class, size, volume, and weight in a manner that they do not shift or move during at-sea periods, using methods and equipment as approved by higher authority.¹³⁶

- Class – act of storing supplies segregated by the Department of Defense ten supply classes in order to facilitate handling¹³⁷.
- Size – act of storing supplies segregated by class into further parcels in order to accommodate square foot restrictions on board conveyances.

- Volume – act of storing supplies segregated by class into further parcels in order to accommodate cubic foot restrictions on board conveyances.
- Weight – act of storing supplies segregated by class into further parcels in order to accommodate weight (lbs/tons) restrictions on board conveyances.

The issue items process consists of order fulfillment, pre-positioning, composition, and packaging of materiel and/or equipment in preparation for movement to staging and loading areas, in an operation.¹³⁸

- Order Fulfillment – reconciliation of the consumers request for supplies and verify correct supplies are pre-positioned.
- Pre-Position – place supplies at a designated location to reduce reaction time and ensure timely loading.¹³⁹
- Composition – act of arranging pre-positioned supplies having a specific function in order to be packaged as an entity for ease of movement.¹⁴⁰
- Containerization – use of containers to utilize cargo for transportation and storage. Containerization incorporates cargo packaging, storage, transportation to loading area, and security together with visibility of container and its contents into a distribution system from source to consumer.¹⁴¹

The supply train function encompasses activities associated with delivering products and services to customers via a route, either land, water, and/or air that connects an operating force with a base of operations and along which supplies and forces move.¹⁴² Supply train is also the control of routes to include redundancy to ensure throughput as well as protection to prevent interruption of delivery.

- Protect – preservation of the effectiveness and survivability of supply mission related personnel, equipment, and infrastructure deployed or located within a given operational area.¹⁴³
- Redundancy – shifting of mutually supporting supply routes designed to absorb throughput if main route is cut. Also, prevents initial observations of the whole supply train by the enemy and gives the commander options to move supplies.¹⁴⁴

3.5.1.2 Movement

Movement is the routing of personnel and cargo over lines of communications.¹⁴⁵ Sub-functions of movement are shown in Figure 29.

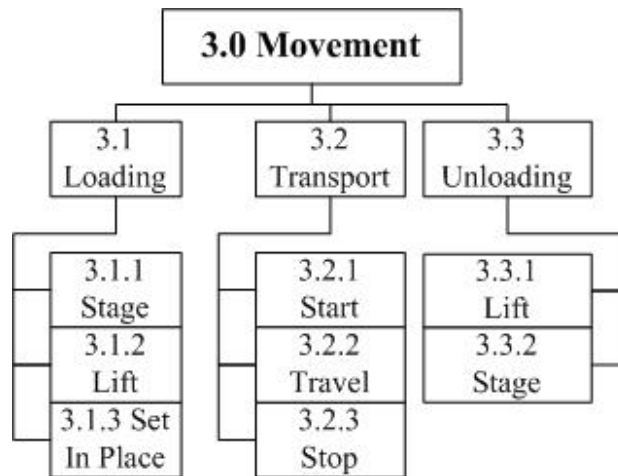

Figure 29. Movement Functional Hierarchy

The loading function is defined as the process of staging, lifting, and setting in place personnel, and materiel on board ships, aircraft, trains, road vehicles, or other means of conveyance not to exceed the total weight of passengers and/or materiel carried on board a ship, aircraft, train, road vehicle, or other means of conveyance.¹⁴⁶

- Stage – organizing and preparation for movement of materiel at designated areas to meet the operational commander’s requirements.¹⁴⁷

- Lift – act of placing materiel on board a vessel using any means available to the unloading entity.¹⁴⁸
- Set in Place – act of properly ordering, organizing and securing materiel on board a vessel in a manner that they do not shift or move during transit.¹⁴⁹

Transport is the start of conveyance along an established supply route, travel along that route and stopping at the desired debarkation point for the materiel carried.

- Start – act of removing any attaching entities and beginning travel to destination.
- Travel – act of moving from starting point to stopping point.
- Stop – act of navigating vessel to desired position and attaching any entities needed to end travel.

Unloading of troops, equipment, or supplies from a conveyance includes the functions of lifting the cargo, and staging for the next phase of movement whether to store or load onto another form of conveyance.

- Lift – act of removing materiel on board a vessel using any means available to the unloading entity.¹⁵⁰
- Stage – organizing and preparation for movement of materiel at designated areas to meet the operational commander's requirements.¹⁵¹

3.5.1.3 Bring Back

Bring Back is the return of personnel or materiel from the area of operations whether by CASEVAC or disposition. Sub-functions of bring back are shown in Figure 30.

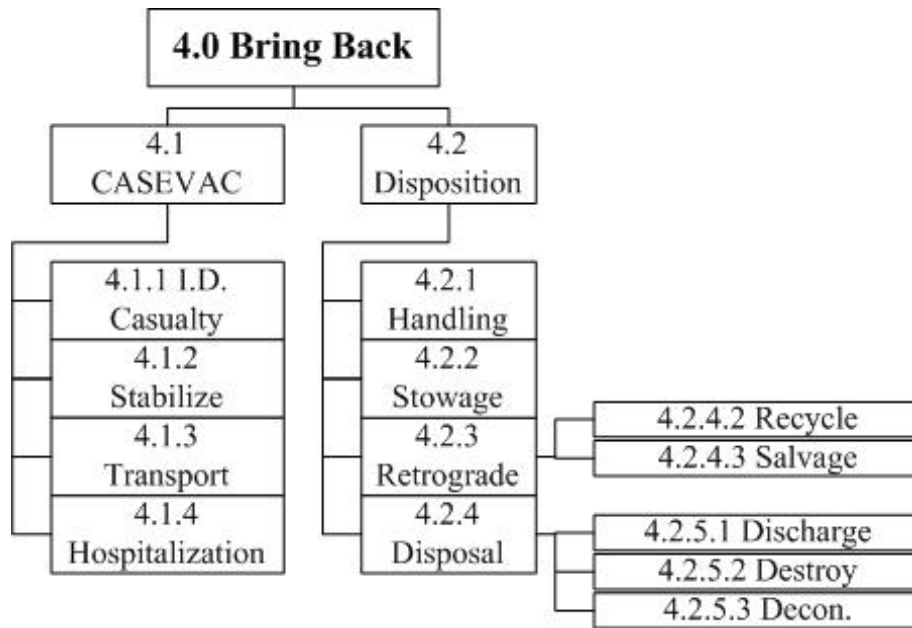

Figure 30. Bring Back Functional Hierarchy

Casualty evacuation (CASEVAC) is the unregulated movement of casualties that can include transport both to and between medical treatment facilities. Functions of CASEVAC also used to specifically identify a casualty for reporting purposes based upon the casualty type and the casualty status.¹⁵²

- Identify Casualty – recognizing a casualty for reporting purposes in order to call for evacuation and begin stabilization.¹⁵³
- Stabilize – act of securing airway, controlling hemorrhage, treating shock, immobilizing fractures, and preparing casualty for evacuation.¹⁵⁴
- Transport – removal of a casualty by any of a variety of transport means (air, ground, rail, or sea) from a theater of military operation to health service center to include en route medical care.¹⁵⁵
- Hospitalization – admitting the casualty to a medical treatment facility capable of providing inpatient care.¹⁵⁶

Disposition is the act of preparing to remove waste from operational areas by proper handling, and stowage. All waste will then undergo either retrograde which

entails recycling and salvage, or disposal which covers discharging, destroying, or decontamination of waste.

- Handling – following proper procedures for the retrieval, storage, or repositioning of non-hazardous, potentially hazardous, and hazardous waste.
- Stowage – placing materiel into a hold or compartment to prevent leaks and prepare for retrograde or disposal.¹⁵⁷
- Retrograde – evacuation of waste from area of operations in preparation for recycling or salvage.¹⁵⁸
- Disposal – discharge, destruction, or decontamination of waste on location if permissible or evacuation of waste from area of operations in preparation for discharge, destruction, or decontamination.

3.5.2 Repair Group

After completion of the systems decomposition and input-output analysis, this study focused on the functions necessary to accomplish the maintenance task in a riverine squadron within the scenario bounds, primarily patrol and interdiction. In order to sustain the force, from a maintenance perspective, the two functions of preventive and corrective maintenance would have to be accomplished with the following sub-functions: repair, replace, adjust, evacuate, and ignore. The repair functional hierarchy is shown in Figure 31.

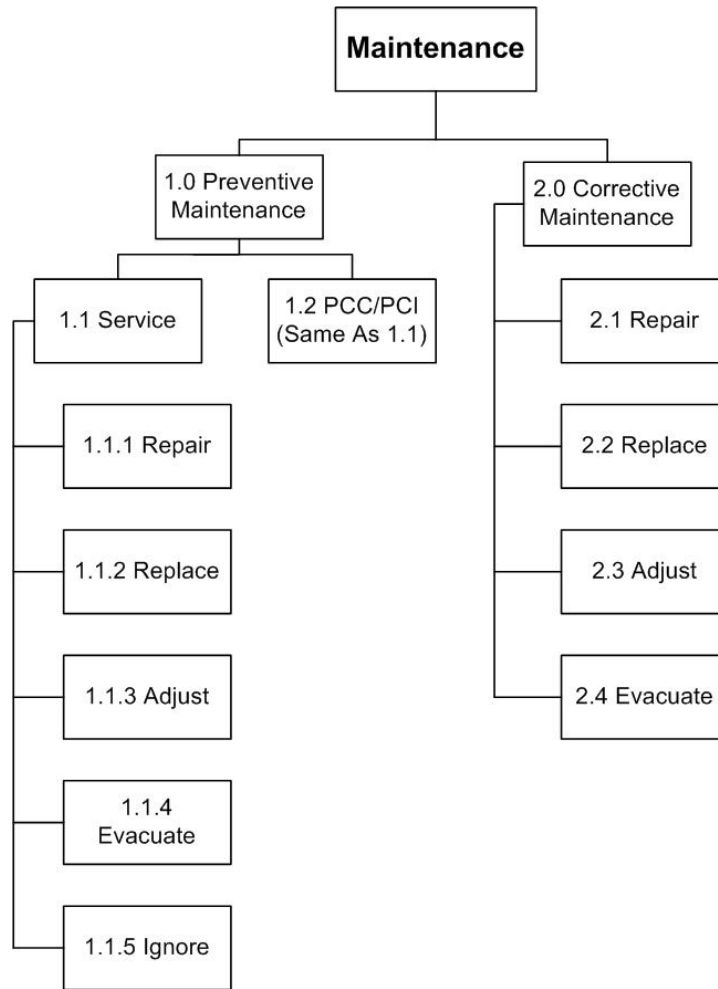

Figure 31. Repair Group Functional Hierarchy.

The sub-function preventive maintenance represents the tests, measurements, adjustments (calibration), and parts replacement, performed specifically to prevent faults from occurring. This sub-function allows for the systemic inspections, malfunction detection, and correction of incipient failures either before faults occur or before they develop into major defects. This sub-function differs from corrective maintenance in that it is executed according to a schedule determined by the manufacturer. Notional examples of preventive maintenance include the replacement of the air filter upon 1000 hours of use, or a monthly fire extinguisher check.

The corrective maintenance sub-function represents those actions carried out to restore a defective item to a specified condition in which the item is fully mission cable

and can successfully complete its mission. According to Marine Corps, “the detection of the defective equipment may occur during routine preventive maintenance checks and services or through operational failure of equipment.”¹⁵⁹ It includes the same functions as preventive maintenance; however, the phases of corrective maintenance are not governed by a discrete schedule, and can be very time consuming due to the inherent nature of corrective maintenance. Phase I involved problem isolation, Phase II required repair parts are obtained, and Phase III entailed correcting the faulty equipment.

The core of the preventive maintenance sub-function is service. Service represents operations performed periodically to keep the item in proper operating conditions; i.e., clean, preserve, drain, paint, and replenish fuel levels, lubricants, and hydraulic fluids. Scheduled inspections of various parts and components of the equipment are checked for malfunctions and replaced or repaired as necessary.

Pre-Combat Checks and Inspections (PCC/PCI) are included under the preventive maintenance sub-function, as they occur according to a time schedule based on mission timelines. PCC/PCI’s are necessary checks and inspections of equipment prior to executing a combat mission or before the routine use of equipment. Commanders normally specify PCC/PCI’s in operations orders or through memorandum and require a back brief in regards to the status of critical items of equipment prior to executing the mission or routine use of the equipment.

The service and PCC/PCI sub-functions represent different ways in which faults are detected. However, after identification of a malfunction, the faults are corrected in the same manner through repairing, replacing, ignoring, adjusting or evacuating. In corrective maintenance the types of malfunctions under consideration would have a detrimental effect on the mission and thus cannot be ignored, hence the ignore function is not included under this function.

The repair, replace, adjust, evacuate and ignore sub-functions were developed using U.S. Army and Marine Corps doctrine and are now described. Repair represents restoring the item to a serviceable condition by replacing unserviceable parts or by any other action required, using available tools, equipment, and skills including welding,

grinding, riveting, straightening, adjusting, facing, etc. Replace is ordering serviceable components, assemblies, and sub assemblies for unserviceable parts. It also represents, when necessary, the replacement of the entire end item, i.e. boat or truck, when necessary. Adjust represents the necessary calibrations made periodically to optimize system performance. Evacuation represents two processes, first moving by towing or lifting a SURC back to the FOB or MOB for repairs performed by the squadron's maintenance team. Second, it represents evacuating the item out of theater for depot level maintenance, outside the capability of the riverine squadron. Ignore is the action of not doing anything when a defect is found. This can occur when operational engagements preclude maintenance, or when dictated by the unit commander. This study focused on malfunctions that would cause mission failure so this action is not considered in the study, but it is mentioned as it was considered in our analysis.

3.5.3 Force Protection Group

The first three tiers of the functional hierarchy for the FPS are shown in Figure 32.

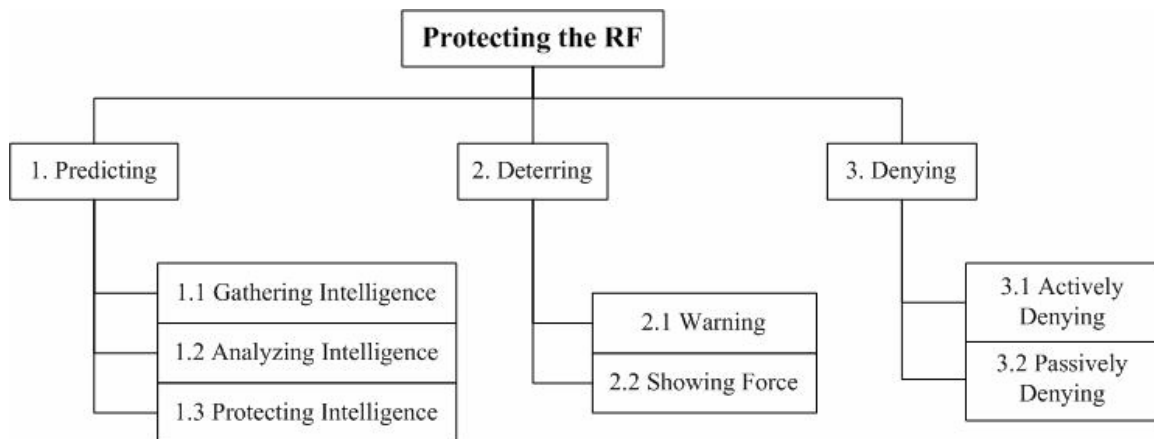

Figure 32. Force Protection System Functional Hierarchy

As described in the system decomposition of force protection, the sub-functions of protecting the RF were predicting, deterring, and denying the threat. Although predicting the threat is not intrinsic to protecting the RF, the degree of success in this area served as an amplifying or reducing factor for the other two functions. Successful

predictions allowed the FPS to accurately scale defenses and consider tactics in preparation of an attack by insurgents, thus increasing denial and deterrence. Likewise, misused or uncollected intelligence decreased deterrence and denial. The sub-functions of predicting the threat were gathering intelligence, analyzing intelligence, and protecting intelligence. Gathering intelligence meant the collection of intelligence from people and equipment comprising the FPS. Analyzing intelligence meant filtering intelligence to extract useful information. Finally, protecting intelligence meant securing friendly intelligence from the enemy.

The next sub-function of protecting the RF was deterring the threat. The sub-functions of deterring were warning and showing force. Warning and showing force comprised the mechanisms through which deterrence was accomplished because both elements were ways of indicating to the enemy that any threatening actions may not succeed. The RST defined warnings as the actions intended to inform civilians and deter hostile forces. The sub-functions of warnings were visual and audible queuing, as they comprised how warnings were accomplished. Visual queuing meant that warnings were transmitted to people through their visual senses, and audible queuing with an equivalent definition. Showing force by the FPS was defined as the combination of actions that demonstrated the capability of the RF and coalition forces which would effectively deter enemy aggression. Although showing force may be considered as a manifestation of visual and audible warnings, it defers from these concepts in the RST's definition because a show of force may not be directly intended as a warning. Showing force was often used as a means to prepare the RF for possible enemy actions. Showing force included the sub-functions of conducting operations and fortifying structures. Conducting operations were the practiced assaults and changes in posture designed to intimidate possible attackers. In the operational environment, these operations were called random anti-terrorist measures. Fortifying structures meant additions to structures to make them less susceptible to attacks, thereby discouraging enemy actions.

The final sub-function of protecting the RF was denying the threat. Denying the enemy a successful attack was accomplished by actively and passively denying the enemy. The RST defined actively denying as denying the enemy a successful attack

through action directed at the enemy. The sub-functions of actively denying were the functions of the detect to engage sequence. There are several different constructs of the particular functions involved in this sequence, but for the purposes of this study, the RST used a construct that was comprised of the functions detect, locate, track, identify, and engage. Detection was defined as “the perception of an object of possible military interest but unconfirmed by recognition.”¹⁶⁰ The RST defined locate as simply locating the object. Track meant “to display or record the successive positions of a moving object.”¹⁶¹ Identify was defined as “The process of determining the friendly or hostile character of an unknown detected contact.”¹⁶² Finally, engage meant “to bring the enemy under fire.”¹⁶³

The RST defined passive denial as denying the enemy a successful attack through inaction or actions not directed at the enemy. The sub-functions of passively denying were blocking, concealing, and moving. The RST defined blocking as physically obstructing the enemy’s weapons from affecting intended targets. Concealing meant masking critical facilities, weapons, and equipment from the enemy. Moving meant simply moving away from a threatening area.

3.6 FUNCTIONAL FLOW DIAGRAM AND CONTEXT MODEL

A Functional Flow Block Diagram (FFBD) is a tool describing the system and its elements in functional terms.¹⁶⁴ FFBD’s should include coverage of all activities in a systems life cycle and show proper activity sequences and interface interrelationships.¹⁶⁵ The RST compiled FFBD’s for each of the three overarching functions of sustain and one for communications. Each FFBD’s starts with top layer functions and then decomposes these functions into second and third layer functions. This decomposition allows for the RST to describe the system in functional terms and shows what is required of each function rather than how each function should be accomplished.¹⁶⁶

3.6.1 Supply Group

The supply enhanced FFBD used control structures such as iteration and looping in order to add simplicity to a complex flow of functions. Looping was a control

structure that was a repetition of a unique set of functions until exit criterion was satisfied. A loop control structure began and ended with a loop (LP) node. An iteration control structure was a repetition of a unique set of functions until a domain set was satisfied. An iteration control structure began and ended with an iteration (IT) node.¹⁶⁷ The FFBD also used AND nodes to show that all functions occurred simultaneously and the flow could not continue on until the process was complete. An OR node showed a decision based on certain criteria. The RST supply FFBD is shown in Figure 33. The overall FFBD began with issue items (to base) which started the FFBD of materiel from the delivery vehicle to the RF. The output of the FFBD was the bringing back of waste as needed and a feedback loop to send the request for needed materiel.

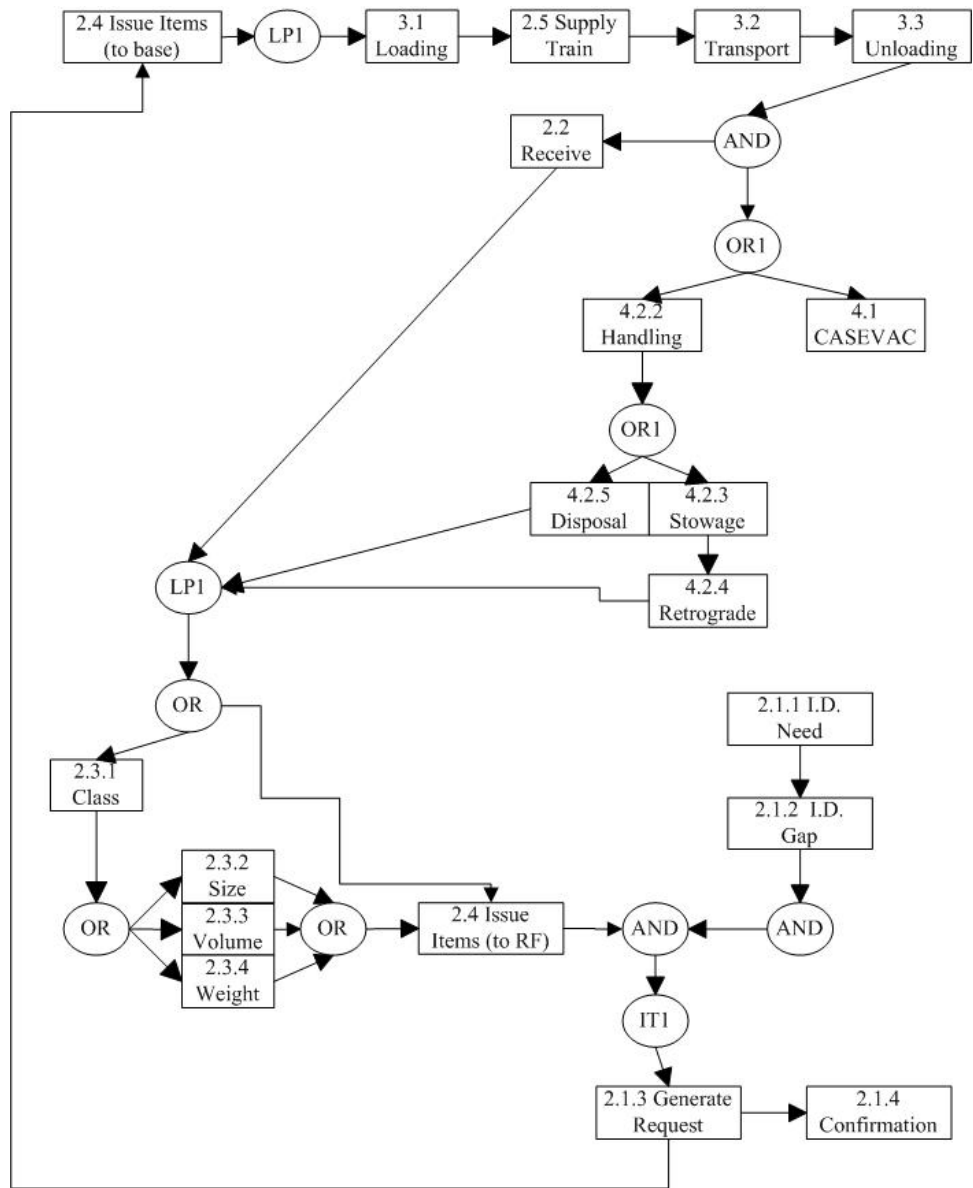

Figure 33. RST Supply Functional Flow Block Diagram

The first fidelity test of the FFBD was to send a bullet to the RF. The bullet was issued to the base (function 2.4) and loaded (function 3.1) onto the logistic connector. Upon loading completion, the supply train (function 2.5) dictated which route to follow and if additional protection was needed. The logistic connector started, traveled, and stopped (function 3.2) at the basing alternative of the RF.

The bullet was then unloaded (function 3.3) and the RF began the receiving process (function 2.2) as well as the retrograde and disposition processes (functions 4.2.4

and 4.2.5). This loop (LP1) was repeated until all bullets were removed from the delivery ship and accounted for by the RF and all waste transported out of the operational area. Upon receipt completion, the issue of items to RF (function 2.2) began or the bullets were placed into storage by class (function 2.3.1), size (function 2.3.2), volume (function 2.3.3), and weight (function 2.3.4) for later issue to the RF.

Accounting for the items issued (function 2.4), identifying the gap (function 2.1.2), and identifying the need (function 2.1.1) all fed into the request generation (function 2.1.3) and confirmed (function 2.1.4). This request was a direct feedback into the issue items to base (function 2.4) to ensure the correct amount of materiel continued to flow.

The second set-up to test the response of the FFBD was to cause an interruption in sending a bullet to the RF. The bullet was issued to the base (function 2.4) and loaded (function 3.1) onto the logistic connector. Upon loading completion, the supply train (function 2.5) dictated which route to follow and if additional protection was needed. The logistic connector started, traveled, and while traveling was lost due to enemy hostility. The bullet was never received (function 2.2) and retrograde and disposition (functions 4.2.4 and 4.2.5) never occurred. The loop (LP1) was repeated until all bullets were removed from the delivery ship but due to enemy action, all bullets have been lost. Therefore the loop ends, however issuance of items to RF (function 2.2) continued.

Accounting for the items issued (function 2.4), identifying the gap (function 2.1.2), and identifying the need (function 2.1.1) all fed into the request generation (function 2.1.3). However, the gap identified (function 2.1.2) was much larger. The request was generated (function 2.1.3) and confirmed (function 2.1.4). The request was a direct feedback into the issue items to base (function 2.4) to ensure the correct amount of materiel continued to flow.

3.6.2 Repair Group

The following assumptions were considering when developing the preliminary Maintenance Flow Diagram (MFD):

- All malfunctions detected in the process were mission critical.
- They degraded the operational readiness of the troops in the Area of Operations if no actions were taken to rectify them.
- Although all of the maintenance personnel were well-trained, such that there was a reasonable expectation that they could perform all maintenance tasks within their Level of Repair, some malfunctions fell beyond the skill level of the nine maintenance personnel.

These assumptions were met with the following constraints in the further development of the MFD: operational readiness, level of repair, time, and parts availability. Operational readiness was the overarching factor that determined how the maintenance procedures were designed and implemented. As a function of the SURC reliability and its subcomponents, operational readiness calculations were used to determine how often there would be a critical failure. Operational readiness is also a function of re-supply times, repair times and the availability of maintenance personnel to conduct repairs. The level of repair limited the types of malfunctions that could be rectified by operators under operational environments and conditions. For the purposes of this study, the Level of repair was limited to the first and second echelons of organizational maintenance, and the third echelon of intermediate maintenance. At the lowest echelon, repairs consist of cleaning and greasing, and other such tasks. The second echelon is where scheduled maintenance and fault isolation takes place and is performed by skilled personnel. The third echelon involves tasks that may include minor hull/structural (welding) repair and installing external parts. In all three of these levels, “Plug and Play” modularity in SURC maintenance and strong parts support are vital to decreasing the amount of time it takes to return a faulty system to the desired level of readiness, thereby allowing the commander maintain a high level of operational reliability. In this case, time refers to the total amount of delay between the identification of malfunctions to the instant the equipment is ready for deployment.

Upon identification of a malfunction, the commander had four options: repair, replace, ignore or evacuate, which he had to decide so as to fulfill the minimal operational readiness required for mission accomplishment. The functional flow diagram, Figure 34, shows how each SURC, and its associated parts, flowed through the maintenance system, both for preventive and corrective maintenance. That is, malfunctions were identified during preventive maintenance, pre-combat inspection, or through operator diagnosis which required corrective maintenance.

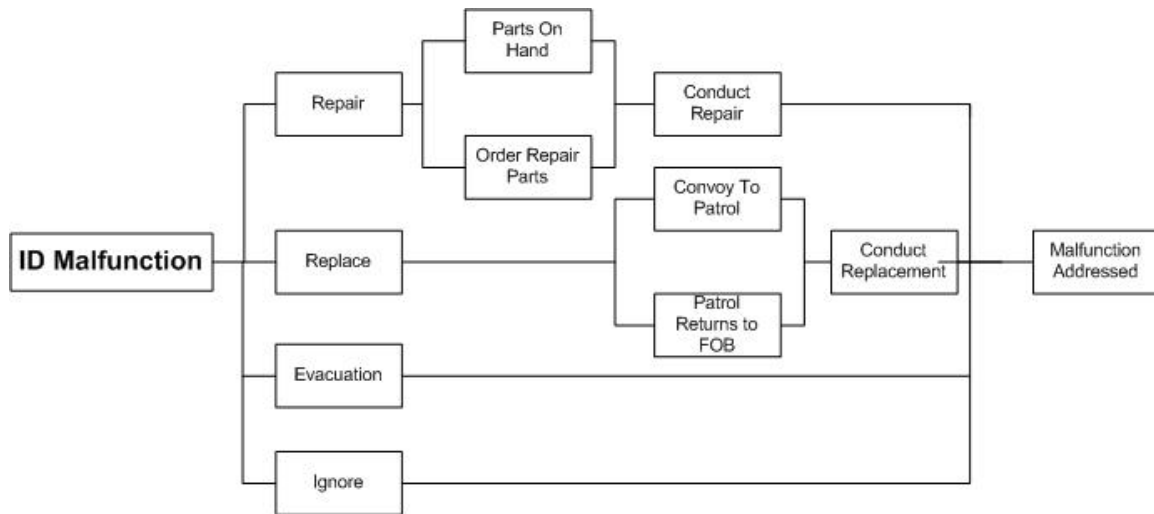

Figure 34. Maintenance Functional Flow Block Diagram

If repair is selected, then flow involved the time to order and replace parts, and return the SURC to normal operation. If the commander decided to replace the boat, a replacement was sent forward to the patrol area, and the defective boat was towed to the FOB for repairs. For malfunctions that did not affect the patrol's mission, the commander chose to ignore the fault. Malfunctions requiring level four echelon intermediate maintenance, which involves heavy body, hull turret, and frame repair, or depot level maintenance (e.g., overhaul, fabrication, machining, etc.), an evacuation of the damaged SURC was coordinated and a replacement was brought forward into the AO. Replacement in this study refers to the replacement of the entire boat and not just the malfunctioned parts. The RST looked at three possible scenarios where the replacement option was selected. First, the malfunction identified was beyond the skill level of the operators, and if the boat was essential for mission accomplishment it had to

be replaced. Second, the malfunction identified was within the skill level of the operators, but the total time required for repair was greater than that of a replacement, based upon the availability of replacement parts at the FOB. The third situation involved a boat that was damaged beyond immediate repair, away from the FOB, and the commander had to decide whether or not to tow the damaged boat back to the FOB and send in a replacement. This decision was primarily based on how far the boat is into its eight hour mission. If the commander chose to ignore the malfunction, the boat continued on patrol. Evacuation represented the instance when the equipment needed to be moved to a depot level maintenance facility, either ashore or afloat, and is no longer a responsibility of the squadron's maintenance system except for accountability (i.e., the overall calculation of the percentage of the squadron's boats which are fully mission capable).

3.6.3 Force Protection Group

The FPS functional flow demonstrated the functional order of the FPS as it would appear in any scenario. Figure 35 shows the second and third level functional flow.

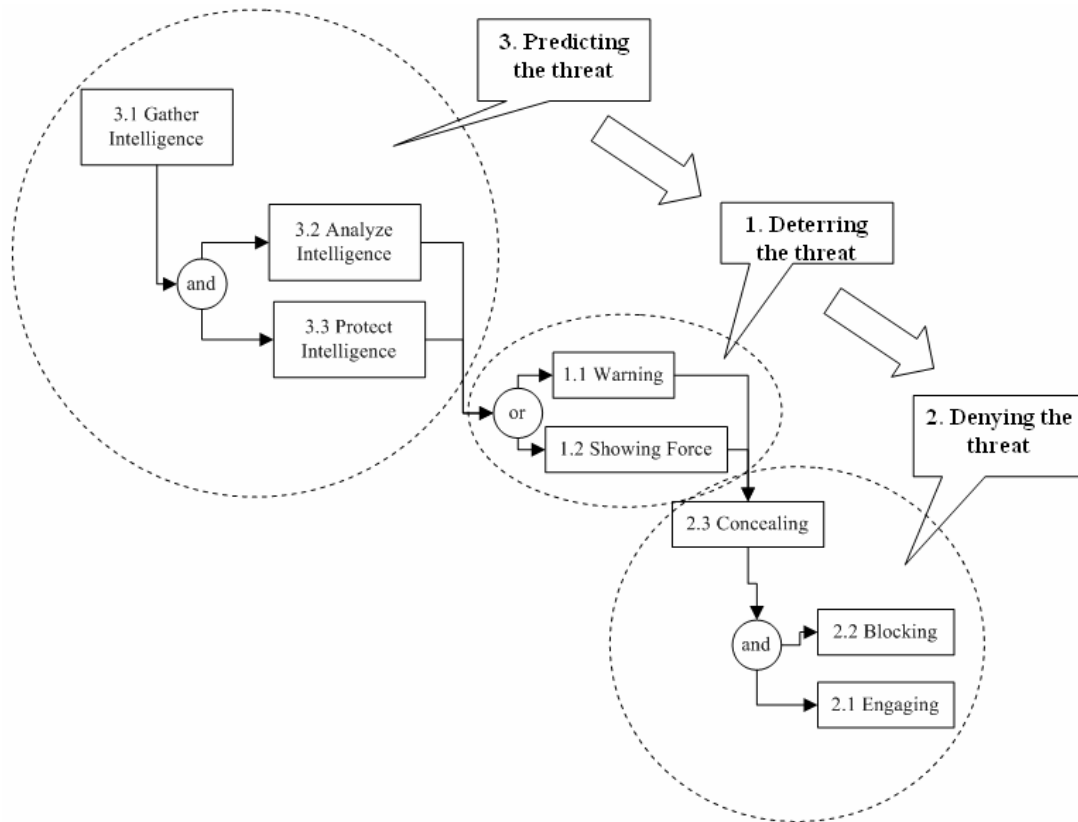

Figure 35. Force Protection Functional Flow Block Diagram

From the Force Protection Functional Hierarchy, gathering intelligence, analyzing intelligence, and protecting intelligence were the sub-functions of predicting the threat. Before attempting to deter or deny the threat, the FPS tried to predict the threat to effectively coordinate defensive activities based on the threat. Gathering intelligence was the first sub-function of predicting the threat because no predictions could be made without intelligence. Intelligence could be gathered by the FPS or from other sources. For example, coalition partners may notice some unusual traffic activity and would seek follow up observations by the personnel of the FPS. This gathered intelligence would then flow into the next two sub-functions of predicting the threat, analyzing and protecting intelligence. In the previous example, the FPS would take observations of the traffic and check against historical data or past observations to deduce if there was something unusual. In the meantime, analyzed data and analysis conclusions would be secured from enemy forces.

The next function that occurred during protection is deterring the threat. Deterrence occurs to avoid being attacked and, likewise, avoid having to deny the enemy a successful attack, so this function occurred before denying. The sub-functions for deterring the threat were warning and showing force. Warnings and showing force were independent methods of achieving deterrence, so the “or” block was used between the two.

The final group of functions that occurred in the process of protection was the sub-functions of denying: engaging, blocking, and concealing. Concealing was the first function that would occur in these sub-functions because critical facilities should be masked in the initial construction of the base, so concealing would occur prior to an attack by the enemy. As intelligence on possible attacks became more available, changes in concealment may occur. The next two functions, engaging and blocking, would occur simultaneously, so the “and” block was used between these two functions. The construction process to increase blocking might occur long before an enemy attack, but the act of blocking the enemy’s weapons does not occur until the enemy attacks. The enemy may be engaged before the enemy is able to fire a weapon, but if the enemy is able to make the first strike on our forces, the two engaging and block would occur simultaneously.

3.7 REVISED PROBLEM STATEMENT

Often a design team will plunge into a project without thoroughly investigating what the top level objectives of the project are or should be. Even as the needs analysis progresses, needs and problem statements may have to be "adjusted" to incorporate new information. What was first thought to be a bona fide need may suddenly be transformed into another one. However, the goal of the project should remain the same; the apparent need simply becomes different as the designer understands it better.¹⁶⁸

After completing most of the functional architecture, the RST adjusted the problem statement: “Define, analyze, and recommend alternatives for supply, repair, and force protection that increase sustainability of the riverine force in the riparian environment utilizing technologies currently in use or available for use by 2012.”

3.8 OBJECTIVES HIERARCHY AND METRICS

Purpose of the hierarchy of objectives is to find what is important to the system's stakeholders in a value sense; that is, the stakeholders would (should) be willing to pay to obtain increased performance (or decreased cost) in any one of these objectives.¹⁶⁹ Using the revised problem statement as the top level objective to be achieved an objectives hierarchy was built using the functional hierarchy as a guide to account for all functions have a purpose in the system. If any functions objective is deemed unnecessary the function would then not be an integral part of the system. Therefore, the function could be eliminated or rolled into a similar function to fit the stakeholder objectives.

The RST broke the riverine systems of systems into four functional areas: engage, deploy, C4ISR, and sustainment. The sustainment function was further narrowed down to supply, repair, and protect. Each one of these top level functions were further decomposed into a functional hierarchy which was used to create an objective hierarchy for each function of supply, repair, and protect.

3.8.1 Supply Group

The objective of supply was to ensure that the customer receives “what they want”, “when they want it”, “where they want it”. Ensuring that the customer has the ability to do the task at hand was the major objective of the logistics team. If the customer lacks the materiel to complete the job then supply was not performing correctly. The key evaluation measure (EM) for supply was percent of time that the MIO mission was halted due to lack of materiel, such as fuel, water, food, repair parts, or ammunition.

The effective need was to design a supply system to move materiel to a forward base (ashore or afloat) in a logistically barren area. Specifically, the system must transport, store, and distribute materiel, as well as return waste as efficiently and effectively as possible. Using the effective need as the top level objective the RST was able to create a top level objective hierarchy based upon the functional hierarchy and adding in the attributes of the system. The top level objective hierarchy is shown in Figure 36.

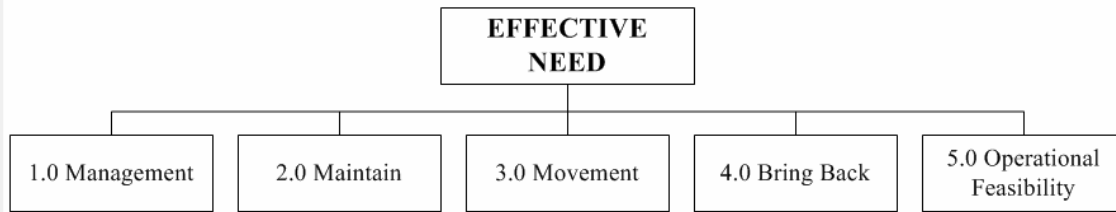

Figure 36. Top Level Supply Objectives Hierarchy.

The RST took each of the top level functions in the objective hierarchy and decomposed the functions to include an objective statement and an EM. Further breaking down each of the sub-functions to also include an objective statement and an evaluation measure created a lower level objective hierarchy in which metrics could be determined. The metrics could then be grouped into lower level evaluation measures to quantify the results for certain functions of the system. The lower level evaluation measures were then combined to create overarching evaluation measures in order to have a quality to compare each of the basing alternatives and logistic connector alternatives.

The first function of management was considered to be integral to this system however, our primary focus was on the functions of maintain, movement, and bring back. Therefore management was explained in detail as a part of Appendix F. Every EM has factors that are either time based, percent based, or effect based. Effects are multipliers that either raise or lower the quantity. For example a learning effect of 0.9 lowered the load time of a logistics connector while a learning effect of 1.1 raised the load time of a logistics connector. All of the factors under each objective were what the RST consider to be the most influential. The RST realizes there are many factors that are not included due to limitations in time and modeling but recommend each of these objectives for further study to explore the trade space of each factor.

3.8.1.1 Maintain

The second function of supply was maintain as shown in Figure 37. The function of Maintain had four sub-functions of request, receive, storage, and issue items.

The objective of 2.0 Maintain was to ensure flow of materiel. Every logistics connector event dealing with the logistics train had a maintain entity.

EM2.0: Accurate Flow of Materiel

Factors:

- EM2.1 Accurate Relay of Need (%)
- EM2.2 Accuracy of Receipt (%)
- EM2.3 Accuracy of Storage (%)
- EM2.4 Performance of Issue Items (%)
- EM2.5 Supply Train Performance (%)

Supply Accuracy Equation:

$$Accuracy = Request * Receive * Storage * Issue * SupplyTrain$$

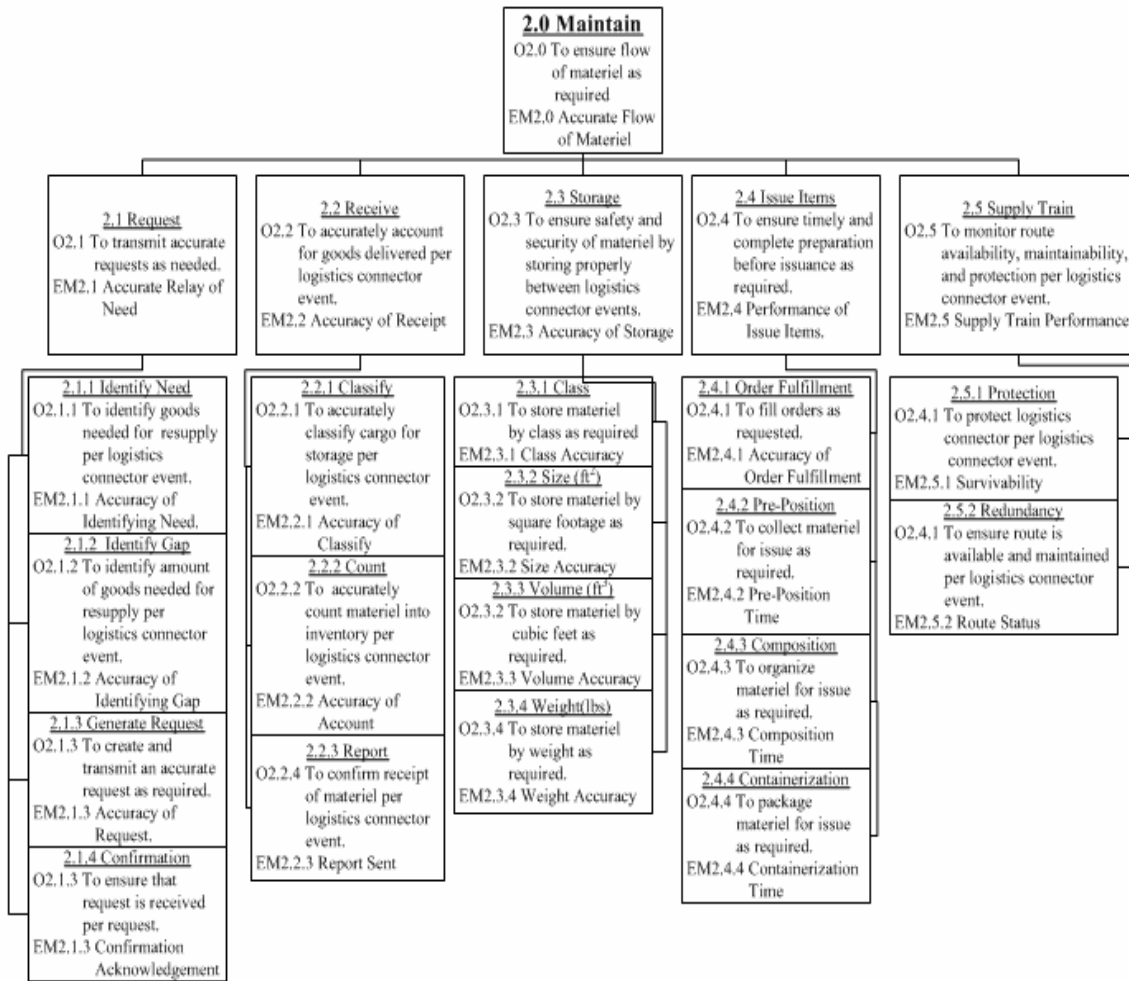

Figure 37. Maintain Objectives Hierarchy

The objective of 2.1 Request was to transmit accurate requests as needed.

EM2.1: Accurate Relay of Need

Factors:

- EM2.1.1 Identifying Need (%)
- EM2.1.2 Identifying Gap (amount of materiel)
- EM2.1.3 Request Generation
- EM2.1.4 Confirmation Acknowledge

Accurate Need Equation:

$$\text{AccurateNeed} = \text{Need} * \text{Gap} * \text{Request} * \text{Confirmation}$$

The objective of 2.1.1 Identify Need was to correctly identify goods needed for supply per logistics connector event. This EM quantifies the percentage of time that the personnel correctly record the material needed and do not identify materiel needed as food when in actuality it is fuel.

EM2.1.1: Identifying Need

Factors:

- Learning Effect (due to competency, knowledge, experience, training)
- Storage Accessibility (percentage of time the storage area was accessible to physically view materiel on hand to determine need)
- Following Procedure (percentage of time that the personnel identify the needed materiel correctly following procedures)

Identify Need Equation:

$$\text{Need} = \text{Procedures} * \text{Accessibility} * \text{Learning}$$

The objective of 2.1.2 Identify Gap was to correctly identify amount of materiel needed for supply per logistics connector event.

EM2.1.2: Identifying Gap

Factors:

- Current Level (amount of materiel at base)
- Max Storage Level (amount of storage for materiel at base)
- Historical Consumption Rate
- EM3.0 Total Movement Time

Identify Gap Equation:

$$Gap = MaxStorage - Currentlevel + (HistoricalRate * EM 3.0)$$

The objective of 2.1.3 Generate Request was to create & transmit an accurate request as required. Further study into the system has shown that without a request no materiel will be sent. Therefore the RST decided that EM2.1.3 Request Generation was done on time, and accurate, 100% of the time.

EM2.1.3: Request Generation

Factors:

- Request Generated

The objective of 2.1.4 Confirmation was to ensure that request is received per request. The RST considered this to be a requirement of the system. Therefore the EM2.1.4 Confirmation Acknowledgment was done efficiently and correctly 100% of the time.

EM2.1.4: Confirmation Acknowledgement

Factors:

- Confirmation Acknowledgement

The objective of 2.2 Receive was to accurately count materiel delivered per logistics connector event.

EM2.2: Accuracy of Receipt

Factors:

- EM2.2.1 Accuracy of Classify (%)
- EM2.2.2 Accuracy of Count (%)

- EM2.2.3 Report Sent

Receive Accuracy Equation:

$$\textit{Accuracy} = \textit{Classify} * \textit{Account} * \textit{Report}$$

The objective of 2.2.1 Classify was to accurately classify cargo for storage per logistics connector event. This EM is the percentage of time that personnel correctly classify food as food and fuel as fuel.

EM2.2.1: Accuracy of Classify

Factors:

- Learning Effect (due to competency, knowledge, experience, training)
- Following Procedure (percentage of time personnel follow procedure and correctly classify materiel)

Classify Accuracy Equation:

$$\textit{Classify} = \textit{Procedure} * \textit{Learning}$$

The objective of 2.2.2 Count was to accurately count materiel into inventory per logistics connector event. This EM is the percentage of time personnel are correct when counting the materiel brought into inventory.

EM2.2.2: Accuracy of Count

Factors:

- Learning Effect (due to competency, knowledge, experience, training)
- Following Procedure (percentage of time personnel follow procedure and correctly count materiel)

Count Accuracy Equation:

$$\text{Count} = \text{Procedure} * \text{Learning}$$

The objective of 2.2.3 Report was to confirm receipt of materiel per logistics connector event. The RST considered this to be a requirement of the system. Therefore the EM2.2.3 Report was done efficiently and correctly 100% of the time.

EM2.2.3: Report Sent

Factors:

- Report Sent

The objective of 2.3 Storage was to ensure safety and security of materiel by storing properly between logistics connector events.

EM2.3: Accuracy of Storage

Factors:

- EM2.3.1 Class Accuracy (%)
- EM2.3.2 Size Accuracy (%)
- EM2.3.3 Volume Accuracy (%)
- EM2.3.4 Weight Accuracy (%)

Storage Accuracy Equation:

$$\text{Accuracy} = \text{Class} * \text{Size} * \text{Volume} * \text{Weight}$$

The objective of 2.3.1 Class was to store materiel by class as required. This EM is the percentage of time that the materiel received is stored in the proper place.

EM2.3.1: Class Accuracy

Factors:

- Correct Location (percentage of time materiel is correctly stored in the right location)
- Correct Labeling (percentage of time that the materiel was labeled correctly upon receipt)
- Learning Effect (due to competency, knowledge, experience, training)

Class Accuracy Equation:

$$\textit{Class} = \textit{Location} * \textit{Labeling} * \textit{Learning}$$

The objective of 2.3.2 Size (ft²) was to store materiel by square footage as required. This EM is the percentage of time that materiel required to be stored by square footage is actually stored by square footage.

EM2.3.2: Size Accuracy

Factors:

- Matching Cargo to location by square footage (percentage of time materiel is correctly stored by square footage)
- Learning Effect (due to competency, knowledge, experience, training)

Size Accuracy Equation:

$$\textit{Size Accuracy} = \textit{Matching cargo to ft}^2 * \textit{Learning}$$

The objective of 2.3.3 Volume (ft³) was to store materiel by cubic feet as required. This EM is the percentage of time that materiel required to be stored by volume is actually stored by volume.

EM2.3.3: Volume Accuracy

Factors:

- Matching Cargo to location by cubic feet (percentage of time materiel is correctly stored by volume)
- Learning Effect (due to competency, knowledge, experience, training)

Volume Accuracy Equation:

$$\text{Volume Accuracy} = \text{Matching cargo to ft}^3 * \text{Learning}$$

The objective of 2.3.4 Weight (lbs) was to store materiel by weight as required. This EM is the percentage of time that materiel required to be stored by weight is actually stored by weight.

EM2.3.4: Weight Accuracy

Factors:

- Overloading Logistic Connector (percentage of time logistics connector is overloaded with materiel)
- Learning Effect (due to competency, knowledge, experience, training)

Weight Accuracy Equation:

$$\text{Weight Accuracy} = (1 - \text{Overload}) * \text{Learning}$$

The objective of 2.4 Issue Items was to ensure timely and complete preparation before issuance as required per request. This EM is the performance rating of

how well the RF personnel issue items based on time. The longer the time to issue items the poorer the performance.

EM2.4: Performance of Issue Items

Factors:

- Accuracy of Correct Fulfillment (percentage of time personnel issue an item correctly)
- Preparation Time for issue (time in minutes to prepare items for issuance)

Issue Items Performance Equation:

$$Issue\ Items = Time(1 + (1 - Accuracy))$$

EM2.4A: Accuracy of correct fulfillment

Factors:

- EM2.4.1 Accuracy of Order Fulfillment
- EM2.4.3.1 Accuracy of Composition

Correct Fulfillment Accuracy Equation:

$$Accuracy = Fulfillment * Composition$$

EM2.4B: Preparation Time for issue

Factors:

- EM2.4.2 Pre-Position Time for Issuance
- EM2.4.3 Composition Time
- EM2.4.4 Containerization Time

Issue Preparation Time Equation:

$$\text{Time} = \text{Pre - Position} + \text{Composition} + \text{Containerization}$$

The objective of 2.4.1 Order Fulfillment was to fill orders as requested. This EM is the percentage of time personnel issue items and that item was desired by the requesting party.

EM2.4.1: Accuracy of Order Fulfillment

Factors:

- Learning Effect (due to competency, knowledge, experience, training)
- Accuracy of Order Fulfillment (percentage of time personnel issue items and that item was desired)

Order Fulfillment Accuracy Equation:

$$\text{Accuracy} = \text{Fulfillment} * \text{Learning}$$

The objective of 2.4.2 Pre-Position was to collect items for issue as required. This EM is the amount of time to locate, retrieve, and move items to stage for issuance.

EM2.4.2: Pre-Position Time

Factors:

- Movement for pre-position time (time in minutes to lift, transport, set in place items requested)
- Materiel Search Time (time in minutes to locate and retrieve items requested)
- Learning Effect (due to competency, knowledge, experience, training)

Pre-Position Time Equation:

$$Time = (Pre - Position + Search) * Learning$$

The objective of 2.4.3 Composition was to organize items for issue as required. This EM has a time based component as well as an accuracy component. The accuracy component is the percentage of time personnel issue the correct number of items requested.

EM2.4.3.2: Composition Time

Factors:

- Organization Time (time in minutes to organize items requested for containerization)
- Learning Effect (due to competency, knowledge, experience, training)

Composition Time Equation:

$$Time = Organization * Learning$$

EM2.4.3.1: Composition Accuracy

Factors:

- Learning Effect (due to competency, knowledge, experience, training)
- Composition Accuracy (percentage of time personnel issue the correct number of items)

Composition Accuracy Equation:

$$Accuracy = Composition * Learning$$

The objective of 2.4.4 Containerization was to package materiel for issue as required. This EM is the amount of time in minutes to package all items requested as necessary.

EM2.4.4: Containerization Time

Factors:

- Packaging Retrieval Time (time in minutes to retrieve packing material)
- Organizing Materiel for packaging time (time in minutes to organize packing material)
- Packaging Time (time in minutes to physically prepare the item for issue)
- Issue Time (time in minutes to transfer the items to the requesting personnel)
- Learning Effect (due to competency, knowledge, experience, training)

Containerization Time Equation:

$$Time = (Retrieval + Organizing + Packaging + Issue) * Learning$$

The objective of 2.5 Supply Train was to monitor route availability, maintainability, and protection per logistics connector event.

EM2.5 Supply Train Performance

Factors:

- Route Availability (%)
- Route Maintainability (%)
- Connector Protection (%)

Supply Train Performance Equation:

$$\text{SupplyTrainPerformance} = \text{Availability} * \text{Maintainability} * \text{Protection}$$

The objective of 2.5.1 Protection was to protect logistics connector per logistics connector event. This EM was the percentage of time the logistics connector survives one transport event up the river to deliver materiel and then returning to the supply ship for the next delivery.

EM2.5.1 Survivability

Factors:

- Susceptibility (percentage of time the logistics connector is open to an effective attack)
- Vulnerability (percentage of time the logistics connector is destroyed due to an effective attack)

Survivability Equation:

$$\text{Survivability} = \text{Susceptibility} * \text{Vulnerability}$$

The objective of 2.5.2 Redundancy was to ensure route was available and maintained per logistics connector event. This EM was the percentage of time the logistics connector route can be used for one transport event up the river to deliver materiel and then returning to the supply ship for the next delivery.

EM2.5.2: Route Status

Factors:

- Route Availability (percentage of time the route was open for transit when called for at an unknown point in time)
- Route Maintainability (percentage of time the route was retained in a transit state by personnel)

Route Status Equation:

$$\text{Status} = \text{Availability} * \text{Maintainability}$$

EM2.5.2.1: Route Availability

Factors:

- Weather Effect
- Water Terrain Effect (due to flooding, drought, dams, or debris)
- Route Knowledge – Predictive (intelligence on route)
- Route Certainty (percentage of faith by commander route is available)
- Resource Effect (personnel and equipment to clear river)
- Political Constraints (host nation agreement)
- Hostility Effect (due to enemy fire or massing of troops)

Route Availability Equation:

$$\text{Availability} = f(\text{Weather}, \text{Water Terrain}, \text{Knowledge}, \text{Certainty}, \text{Resources}, \text{Politics}, \text{Hostility})$$

EM2.5.2.2: Route Maintainability

Factors:

- Hostility Effect (due to enemy fire or massing of troops)
- Route Knowledge – Predictive (intelligence on route)
- Resource Effect (personnel and equipment to clear river)
- Learning Effect (due to competency, knowledge, experience, training)

Route Maintainability Equation:

$$\text{Maintainability} = f(\text{Hostility}, \text{Knowledge}, \text{Resources}, \text{Learning})$$

3.8.1.2 Movement

The third function of supply was movement as shown in Figure 38. The function of movement had three sub-functions of loading, transport, and unloading. The objective of 3.0 Movement was to minimize the time per logistics connector event. Every logistics connector event dealing with the logistics train had a movement entity that affected the amount of time needed to transfer materiel.

EM3.0: Total Movement Time

Factors:

- EM3.1 Loading Time (hours)
- EM3.2 Transport Time (hours)
- EM3.3 Unloading Time (hours)
- Transport Event

Total Movement Time Equation:

$$TotalTime = \frac{Loading + Transport + Unloading}{Transport Event}$$

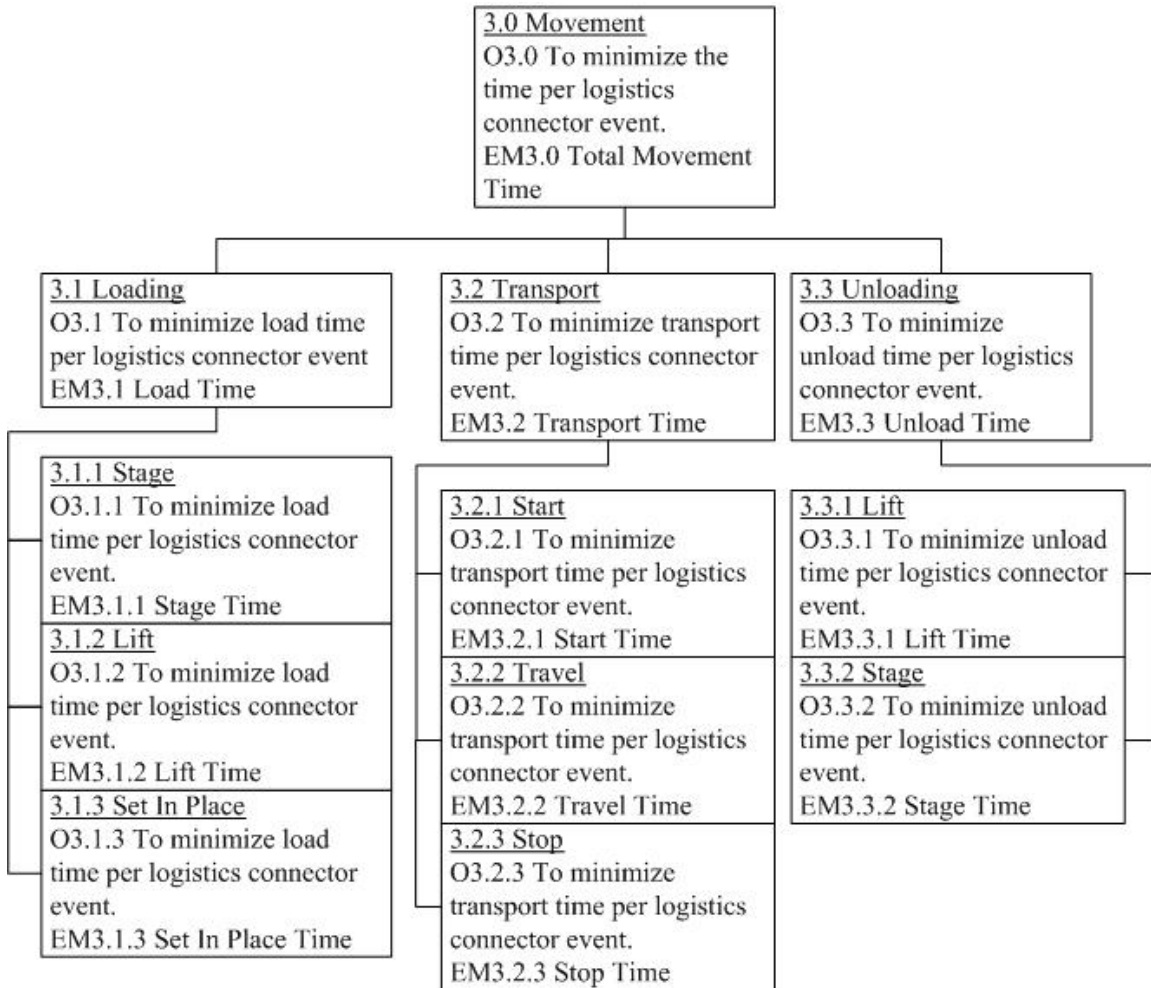

Figure 38. Movement Objectives Hierarchy

The objective of 3.1 Loading was to minimize load time per logistics connector event.

EM3.1: Load Time

Factors:

- EM3.1.1 Stage Time (hours)
- EM3.1.2 Lift Time (hours)
- EM3.1.3 Set in Place Time (hours)

Load Time Equation:

$$LoadTime = Stage + Lift + SetinPlace$$

The objective of 3.1.1 Stage was to minimize the load time per logistics connector event.

EM3.1.1: Stage Time

Factors:

- Travel to Supply Hub Time (hours)
- Maneuvering Time (hours)
- Mooring Time (hours)
- Delay due to Supply Preparation (hours)
- Safety Effect (due to human limits and protecting people)
- Weather Effect
- Learning Effect (due to competency, knowledge, experience, training)
- Illumination Effect (due to natural lighting)

Stage Time Equation:

$$StageTime = (Weather * Learning)((Travel) + (Maneuver + Moor) * Safety * Illum) + (Delay)$$

The objective of 3.1.2 Lift was to minimize load time per logistics connector event.

EM3.1.2: Lift Time

Factors:

- Rigging Time (hours)
- Transfer Time (hours)
- Safety Effect (due to human limits and protecting people)
- Weather Effect
- Learning Effect (due to competency, knowledge, experience, training)

- Illumination Effect (due to natural lighting)

Load Lift Time Equation:

$$LiftTime = (Safety * Weather) * ((Transfer) * Learning * Illum + (Rigging))$$

The objective of 3.1.3 Set In Place was to minimize load time per logistics connector event.

EM3.1.3: Set In Place Time

Factors:

- Placing Time (hours)
- Securing for Sea Time (hours)
- Ballasting Time (hours)
- Safety Effect (due to human limits and protecting people)
- Weather Effect
- Learning Effect (due to competency, knowledge, experience, training)
- Illumination Effect (due to natural lighting)

Set in Place Time Equation:

$$SetInPlaceTime = (Placing + Securing) * Safety * Weather * Learning * Illum + Ballasting$$

The objective of 3.2 Transport was to minimize transport time per logistics connector event.

EM3.2: Transport Time

Factors:

- EM3.2.1 Start Time (hours)
- EM3.2.2 Travel Time (hours)

- EM3.2.3 Stop Time (hours)

Transport Time Equation:

$$TransportTime = Start + Travel + Stop$$

The objective of 3.2.1 Start was to minimize transport time per logistics connector event.

EM3.2.1: Start Time

Factors:

- Casting Off Time (hours)
- Maneuvering Time (hours)
- Equipment Check Time (hours)
- Safety Effect (due to human limits and protecting people)
- Weather Effect
- Learning Effect (due to competency, knowledge, experience, training)
- Illumination Effect (due to natural lighting)

Start Time Equation:

$$StartTime = (Casting + Maneuvering + Equipment) * Safety * Weather * Learning * Illum$$

The objective of 3.2.2 Travel was to minimize transport time per logistics connector event.

EM3.2.2: Travel Time

Factors:

- Weather Effect
- Illumination Effect (due to natural lighting)

- Obscurant Effect (due to smoke, fog, rain, dust, or visual impairment)
- Distance (nautical miles)
- Speed (knots)
- Hostility Effect (due to enemy fire or massing of troops)
- Navigation Effect (due to traffic density)
- Sand Effect (due to dust or sand damaging equipment)
- Ice Effect (due to cold or ice damaging equipment)
- Learning Effect (due to competency, knowledge, experience, training)

Travel Time Equation:

$$TravelTime = \frac{(Distance)}{(Speed * Weather * Illum * Obscurant * Hostility * Navigation * Sand * Ice)}$$

The objective of 3.2.3 Stop was to minimize transport time per logistics connector event.

EM3.2.3: Stop Time

Factors:

- Maneuvering Time (hours)
- Mooring or Beaching Time (hours)
- Equipment Rigging for unload Time (hours)
- Weather Effect
- Safety Effect (due to human limits and protecting people)
- Illumination Effect (due to natural lighting)
- Learning Effect (due to competency, knowledge, experience, training)

Stop Time Equation:

$$StopTime = (Safety)((Maneuvering + Mooring) * Weather * Illum * Learning + (Rigging))$$

The objective of 3.3 Unloading was to minimize unload time per logistics connector event.

EM3.3: Unload Time

Factors:

- EM3.3.1 Lift Time (hours)
- EM3.3.2 Stage Time (hours)

Unload Time Equation:

$$\text{UnloadTime} = \text{Lift} + \text{Stage}$$

The objective of 3.3.1 Lift was to minimize unload time per logistics connector event.

EM3.3.1: Lift Time

Factors:

- Rigging Time (hours)
- Transfer Time (hours)
- Safety Effect (due to human limits and protecting people)
- Weather Effect
- Learning Effect (due to competency, knowledge, experience, training)
- Illumination Effect (due to natural lighting)

Unload Lift Time Equation:

$$\text{LiftTime} = (\text{Safety} * \text{Weather})((\text{Transfer}) * \text{Learning} * \text{Illum} + (\text{Rigging}))$$

The objective of 3.3.2 Stage was to minimize unload time per logistics connector event.

EM3.3.2: Stage Time

Factors:

- Delay due to Supply Receive Preparation (hours)
- Storing Time on Base (hours)
- Safety Effect (due to human limits and protecting people)
- Weather Effect
- Learning Effect (due to competency, knowledge, experience, training)

Stage Time Equation:

$$\text{StageTime} = (\text{Delay} + \text{Storing}) * \text{Safety} * \text{Weather} * \text{Learning}$$

3.8.1.3 Bring Back

The fourth function of supply was bring back as shown in Figure 39. The function of bring back has two sub-functions of CASEVAC and disposition. The objective of 4.0 Bring Back was to return personnel or equipment effectively as required. Every logistics connector event dealing with the logistics train has a bring back entity that affected the amount of time needed to transfer materiel.

EM4.0: Recovery Time Personnel, Disposition Time Materiel

Factors:

- EM4.1 Recovery Time (minutes)
- EM4.2 Disposition Safety (minutes)

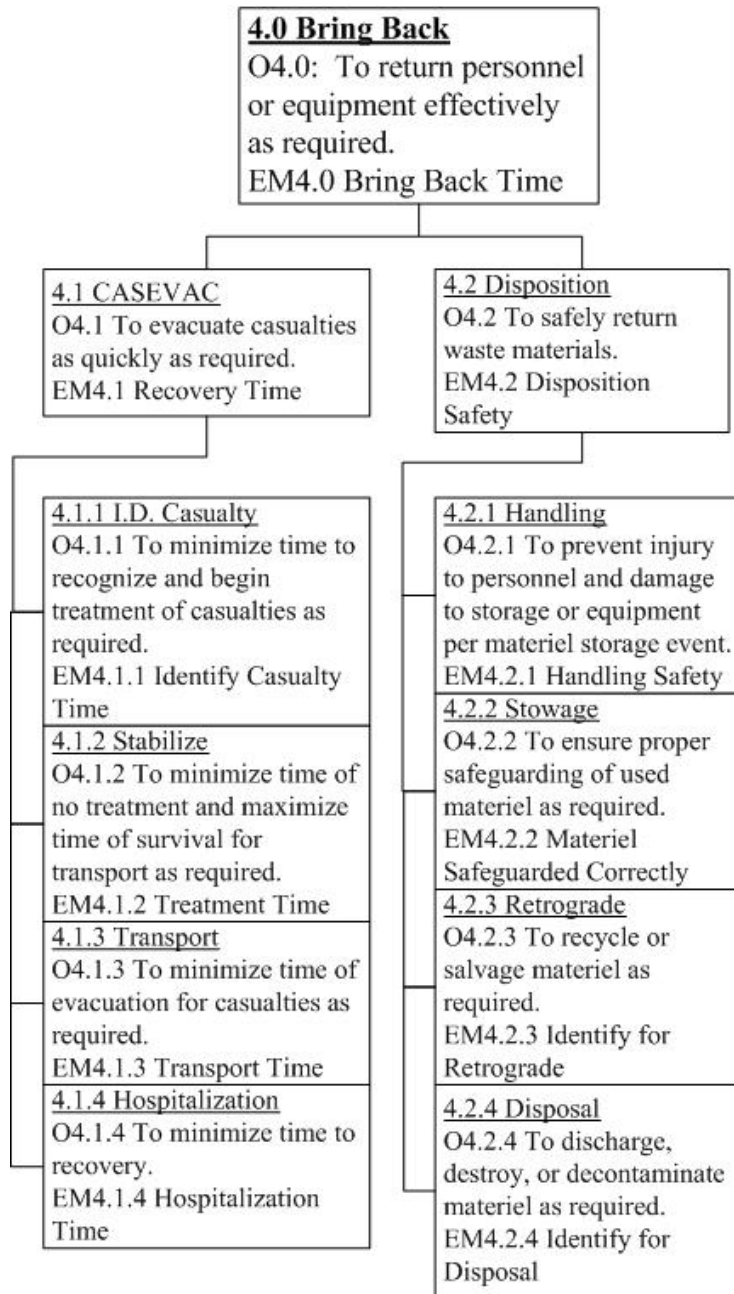

Figure 39. Bring Back Objectives Hierarchy

The objective of 4.1 CASEVAC was to evacuate casualties as quickly as required.

EM4.1: Recovery Time

Factors:

- EM4.1.1 Casualty Identification Time (minutes)
- EM4.1.2 Stabilization Time (minutes)
- EM4.1.3 Transport Time (minutes)
- EM4.1.4 Hospitalization Time (minutes)

Casualty Recovery Time Equation:

$$\text{RecoveryTime} = \text{Casualty} + \text{Stabilization} + \text{Transport} + \text{Hospitalization}$$

The objective of 4.1.1 Identify Casualty was to minimize time to recognize and begin treatment of casualties as required.

EM4.1.1: Identify Casualty Time

Factors:

- Recognize Time (minutes)
- Hostility Effect (due to enemy fire or massing of troops)
- Illumination Effect (due to natural lighting)
- Weather Effect
- Terrain Effect (due to dense jungle and heavy forest)

Identify Casualty Time Equation:

$$\text{IdentifyTime} = (\text{Recognize}) * \text{Hostility} * \text{Illum} * \text{Weather} * \text{Terrain}$$

The objective of 4.1.2 Stabilize was to minimize time of no treatment and maximize time of survival for transport as required.

EM4.1.2: Treatment Time

Factors:

- Retrieval Time (minutes)
- Field Treatment Time (minutes)
- Hostility Effect (due to enemy fire or massing of troops)
- Weather Effect
- Illumination Effect (due to natural lighting)

Casualty Treatment Time Equation:

$$TreatmentTime = (Retrieval + Field) * Hostility * Weather * Illum$$

EM4.1.2.1: Stabilization Time

Factors:

- Treatment Time (minutes)
- Time Factor (hours)

Casualty Stabilization Time Equation:

$$StabilizationTime \propto \left(\frac{1}{TreatmentTime} \right) * TimeFactor$$

The objective of 4.1.3 Transport was to minimize time of evacuation for casualties as required.

EM4.1.3: Transport Time

Factors:

- Distance (nautical miles)
- Speed (knots)
- Number of conveyances (# available)
- Weather Effect
- Illumination Effect (due to natural lighting)

- Terrain Effect (due to dense jungle or forest)
- Hostility Effect (due to enemy fire or massing of troops)
- Learning Effect (due to competency, knowledge, experience, training)
- Navigation Effect (due to traffic density)
- Ice Effect (due to ice or cold damage to equipment)
- Obscurant Effect (due to smoke, fog, rain, dust, or visual impairment)

Casualty Transport Time Equation:

$$TransportTime = \frac{(Distance)}{((Speed * \#Conveyances) * Effects)}$$

The objective of 4.1.4 Hospitalization was to minimize time to recovery.

EM4.1.4: Hospitalization Time

Factors:

- Transport Unload Time (minutes)
- Hospital Readiness Time (minutes)
- Surgeon Availability Time (minutes)
- Following Procedures (probability procedures followed, %)
- Following Doctors Orders (probability doctors orders followed, %)

Hospitalization Time Equation:

$$HospitalizationTime = (Transport + Readiness + Surgeon) * Procedures * DocOrders$$

The objective of 4.2 Disposition was to safely return waste materiel.

EM4.2: Disposition Safety

Factors:

- EM4.2.1 Handling Safety (%)
- EM4.2.2 Materiel Safeguarded Correctly (%)

Disposition Safety Equation:

$$\text{Safety} = \text{Handling} * \text{Safeguarding}$$

The objective of 4.2.1 Handling was to prevent injury to personnel and damage to storage or equipment per materiel storage event. This EM was the percentage of time that waste was properly handled and personnel follow procedures to ensure safety of the basing alternative and personnel assigned.

EM4.2.1: Handling Safety

Factors:

- Correct Retrieval (percentage of time waste was retrieved properly)
- Safely Received (percentage of time that there was no personnel injured in receiving waste materials)
- Correct Packaging (percentage of time the waste material was properly packaged for storage)
- Following Procedures (percentage of time personnel follow procedures while dealing with waste material)

Handling Safety Equation:

$$\text{Safety} = \text{Retrieval} * \text{Receive} * \text{Packaging} * \text{Instructions}$$

The objective of 4.2.2 Stowage was to ensure proper safeguarding of waste material as required. This EM was the percentage of time that waste is correctly safeguarded until retrograded or disposed.

EM4.2.2: Materiel Safeguarded Correctly

Factors:

- Correct Control (percentage of time waste material was correctly controlled)
- Correct Isolation (percentage of time waste material was correctly isolated as required)

Material Safeguard Equation:

$$\textit{Safeguarded} = \textit{Control} * \textit{Isolation}$$

The objective of 4.2.3 Retrograde was to recycle or salvage materiel as required. This EM is the percentage of time that waste is correctly identified for retrograde.

EM4.2.3: Identify for Retrograde

Factors:

- Learning Effect (due to competency, knowledge, experience, training)
- Accurate Identification (percentage of time waste material is correctly identified for retrograde)
- Following Procedures (percentage of time personnel follow procedure to identify waste material for retrograde)

Retrograde Identification Equation:

$$\textit{Retrograde} = \textit{Identification} * \textit{Procedures} * \textit{Learning}$$

The objective of 4.2.4 Disposal was to discharge, destroy, or decontaminate material as required. This EM was the percentage of time that waste is correctly identified for disposal.

EM4.2.4: Identify for Disposal

Factors:

- Learning Effect (due to competency, knowledge, experience, training)
- Accurate Identification (percentage of time waste material was correctly identified for disposal)
- Following Procedures (percentage of time personnel follow procedure to identify waste material for disposal)

Disposal Identification Equation:

$$\text{Disposal} = \text{Identification} * \text{Procedures} * \text{Learning}$$

3.8.1.4 Operational Feasibility

The attributes of the logistic connector operational feasibility are shown in Figure 40. Operational Feasibility was the capability of a system to be satisfactorily integrated and employed for field use. The RST examined many attributes of the logistic connectors and determine that operational feasibility had five sub-attributes of reliability, availability, maintainability, transportability, and manpower supportability. The objective of 5.0 Operational Feasibility was to ensure logistic connectors are feasible for the supply mission as required. Every logistics connector event dealing with the logistics train had an operational feasibility entity that affects the performance of the logistic connector.

EM5.0: Operational Feasibility

Factors:

- EM5.1 Reliability
- EM5.2 Availability
- EM5.3 Maintainability
- EM5.4 Transportability
- EM5.5 Manpower Supportability

Operational Feasibility Equation:

$$Feasibility = f(Reliability, Availability, Maintainability, Transportability, Manpower)$$

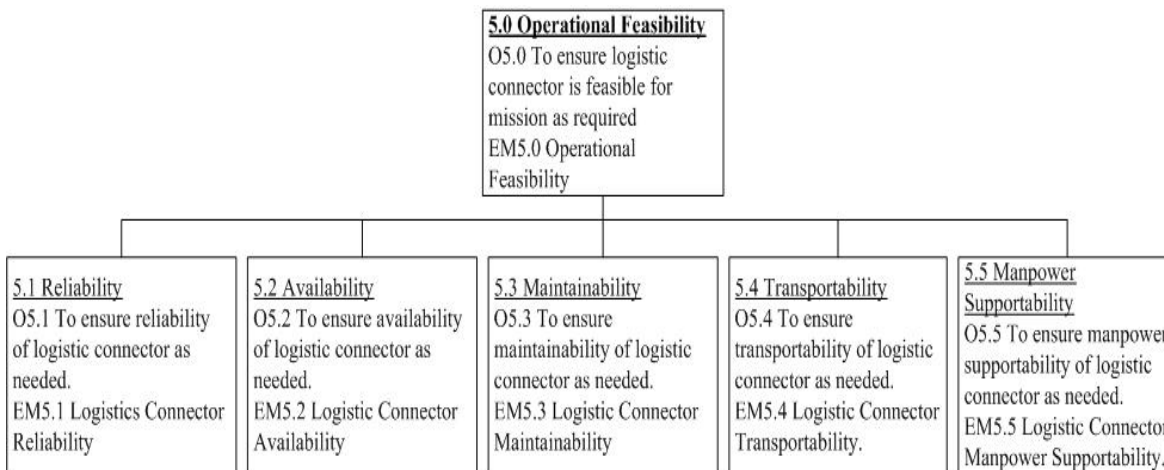

Figure 40. Logistics Connector Operational Feasibility

The objective of 5.1 Reliability was to ensure reliability of logistic connector as needed. The RST determined that the logistics connector must be reliable 100% of the time. The problem in calculating the amount of time for each transport event and the amount of materiel to be moved was considered to be highest priority therefore reliability was assumed to be 100%.

The objective of 5.2 Availability was to ensure availability of logistic connector as needed. The RST determined that the logistics connector must be available 100% of the time. The problem to calculate the amount of time for each transport event and the amount of materiel to be moved was considered to be highest priority therefore availability was assumed to be 100%.

The objective of 5.3 Maintainability was to ensure maintainability of logistic connector as needed. The RST determined that the logistics connector must be maintainable 100% of the time. The problem to calculate the amount of time for each

transport event and the amount of materiel to be moved was considered to be highest priority therefore maintainability was assumed to be 100%.

The objective of 5.4 Transportability was to ensure transportability of logistic connector as needed. The RST determined that the logistics connector was transported and in theater before the supply operation began. The concern was whether the logistics connector was carried by the supply ship and performed its transport runs or the basing option kept control of the logistics connector and met the supply ship at the beginning of every supply cycle. The RST determined the logistics connector would be kept as a part of each basing option and if a logistics connector was lost due to enemy hostility another logistic connector would be delivered before the next cycle time. Therefore, the transportability of the logistics connectors was considered but left to be an area of further study.

The objective of 5.5 Manpower Supportability was to ensure manpower supportability of logistic connector as needed. The RST determined that each logistics connector was capable of operating with the same amount of crew. However the amount of manning on each logistics connector was influenced by weather, hostility, safety, and RAM (reliability, availability, maintainability) effects. Each of these areas was considered by the RST, but because the main metric was time for each transport event and the amount of materiel to be moved, the manpower supportability was assumed to be constant and feasible for all logistic connector alternatives.

3.8.1.5 Overall Supply Evaluation Measures

Based on a completed objective hierarchy the RST was able to create overall evaluation measures that are of grave importance to stakeholders. For the supply objective hierarchy the most important measure was Operational Availability of the SURC due to fuel. This measure was a function of factors including:

- EM2.1 Request
- EM2.5 Supply Train
- EM3.0 Total Movement Time

- EM4.2 Disposition Safety
- Supply Ship Cycle Time

SURC Operational Availability (Fuel) Equation:

$$A_{\text{ofUEL}}^{\text{SURC}} = f(EM2.1, EM2.5, EM3.0, EM4.2, CycleTime)$$

Another measure of vital importance was the Operational Habitability of the basing alternative and logistic connector combination. This measure takes into account the storage level of food and water in order to ensure the RF subsistence. Operational Habitability was a function of:

- EM2.1 Request
- EM2.5 Supply Train
- EM3.0 Total Movement Time
- EM4.2 Disposition Safety
- Supply Ship Cycle Time

Operational Habitability (Food and Water) Equation:

$$H_{\text{ofOOD \& WATER}}^{\text{BASE}} = f(EM2.1, EM2.5, EM3.0, EM4.2, CycleTime)$$

The third overall evaluation measure for supply was throughput. Throughput is defined as the amount of materiel per unit time. This measure was useful in determining which logistics connector performed the best. Throughput was a function of:

- EM2.1.2 Identify Gap
- EM2.5 Supply Train
- EM3.0 Total Movement Time
- Number of Transport Events

Throughput Equation:

$$\textit{Throughput} = \frac{(EM 2.1.2)}{(EM 3.0)(\#TransportEvents)} * (EM 2.5)$$

3.8.2 Repair Group

The elements of this study's objectives hierarchy were comprised of the subject, the objective (O), and the evaluation measure (EM). Objectives were related back to the repair and replacement functions of the functional hierarchy with the additional objective of involving personnel. In order to develop a maintenance system that was both efficient and feasible, the RST sought to minimize the number of personnel and maximize the operational readiness rate (percentage of FMC craft) throughout the squadron. Figure 41 delineates the Maintenance Objectives Hierarch within the RF system.

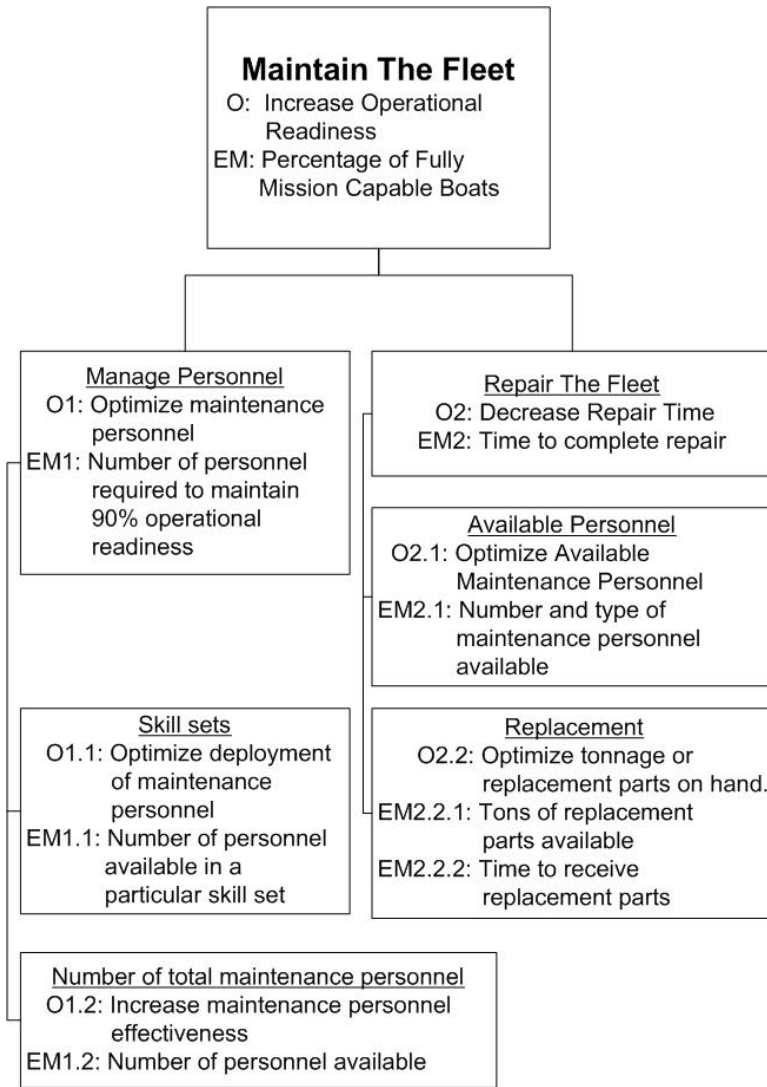

Figure 41. Maintenance Objective Hierarchy

At the time of this study, the maintenance officer from Riverine Group One expressed a concern that there may not be enough dedicated maintenance personnel throughout the squadron to accomplish the riverine mission. One of goals of the RST was to develop a contingent of various types of maintenance personnel and maintenance facility configurations, and evaluate their effect on the time it would take to complete repairs given the availability of replacement parts--the results of which directly influences RF operational readiness.

3.8.2.1 Managing Personnel

The RST determined that two objectives had to be achieved in order to increase operational readiness. The first was to optimize the number and type of personnel available to conduct maintenance. It would be possible but infeasible to increase the total number of personnel and number of personnel in each skill set without limit, so we sought to find that maximum number of personnel and maximum number of personnel in each skill set that would allow the maintenance section to achieve a 90% or better availability rate for the squadron (the inherent availability, or A_i , of SURC's reported by Raytheon in the March 26, 2007 SURC FRACAS indicated an A_i of 98.45%).¹⁷⁰ The type of skill set versus the likelihood of a particular failure is discussed in the following chapter.

3.8.2.2 Repairing the Fleet

The second objective which must be met in order to increase the operational readiness rate was to decrease the mean time to repair (MTTR). In order to decrease the repair time, the RST had to find the optimum amount of available personnel and the optimum tonnage of replacement parts. Optimizing the available personnel pertains to the mathematical efficiency of the number of personnel available to conduct maintenance at any given time. That is, the study's goal was to prove that there was such a thing as too few and too many maintenance personnel with regard to ensuring maximum operational availability of SURC's. Optimizing the tonnage of repair parts represent was defined as having the maximum amount of parts available for repair while at the same time avoiding the mountain of materials on a beach concept. In both cases of personnel and replacement parts onsite was limited by space, as a RF system requirement was a small footprint¹⁷¹ in theatre. Therefore, the numbers of personnel and the tonnage of repair parts had to remain in check.

3.8.3 Force Protection Group

The objectives hierarchy for the FPS was a construct to measure the effectiveness and efficiency of competing architectures for the FPS. The RST traced the objectives

into the functional hierarchy to increase traceability and cohesion of objectives. The objectives and evaluation measures tied into the functions of the FPS provide the analysis of the system's effectiveness. The construct for measuring the efficiency of the system was developed in the operational suitability of the system, which was an independent objectives hierarchy that considered the suitability of a system's architecture.

Each function presented in the functional hierarchy was given a corresponding objective, designated by the "O", but only the lowest level functions were assigned EM's or measures of performance (MOP). With each group of related MOP's, there was an independent measure, or measures, of effectiveness (MOE) designed to provide a higher level of understanding on the performance of the group of MOP's.

The highest level objective for the FPS was to efficiently protect the riverine force at the base of operations by predicting enemy courses of actions and deterring and denying those actions. Figure 42 is the top two levels of functions and their corresponding objectives.

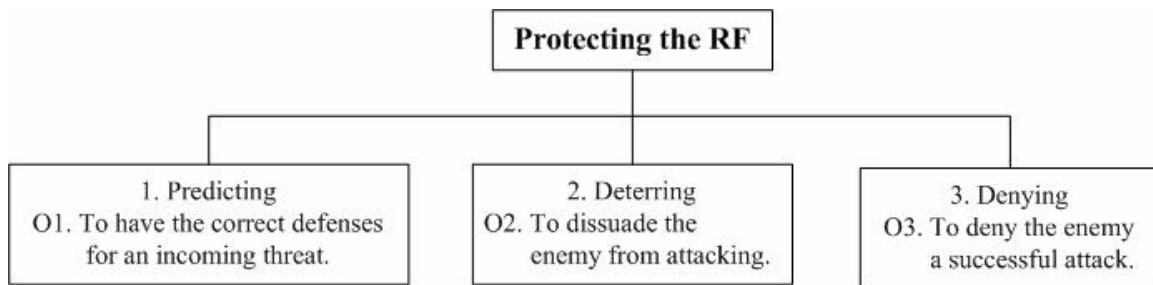

Figure 42. Top-level Functions and Objectives for the FPS

As was stated earlier in the functional hierarchy for the FPS, predicting was the first of the sub-functions that comprised protecting. Figure 43 is the objectives hierarchy corresponding to the functional decomposition of predicting.

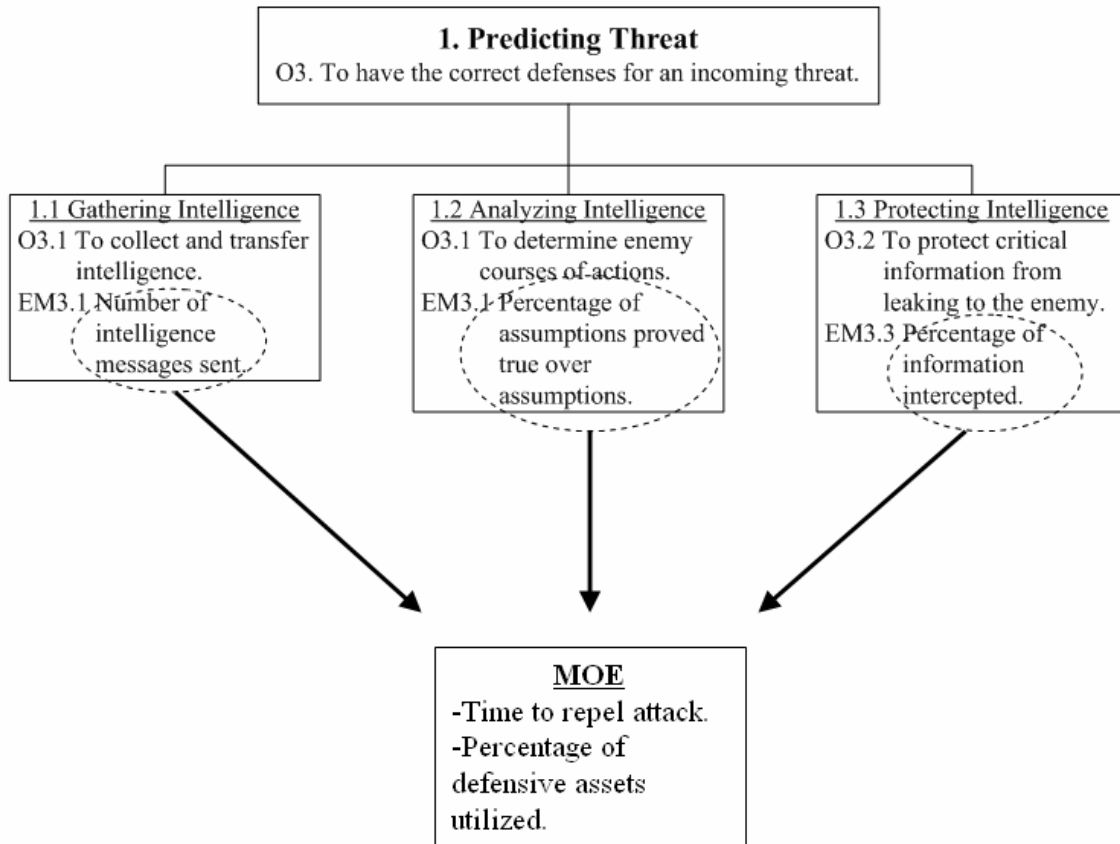

Figure 43. Predicting Threat Objectives Hierarchy

The sub-functions of predicting the threat described in the functional hierarchy were gathering intelligence, analyzing intelligence, and protecting intelligence. The objective of gathering intelligence was to collect and transfer intelligence. The MOP for gathering intelligence was number of intelligence messages sent as this would be representative of the gathering process. In terms of FP, the objective of analyzing the threat was to determine the enemy courses of action. The MOP for analyzed intelligence was percentage of assumptions proved true over assumptions. For protecting intelligence, the objective was to protect critical information from leaking to the enemy with the MOP as percentage of information intercepted.

The MOE for these MOP were time to repel attack and percentages of defensive assets utilized were used. If the FPS was successful at predicting the threat then the time required to repel an enemy attack was minimized. Percentage of defensive assets utilized

was also considered as an MOE to prevent selecting an unnecessarily large FPS. The next sub-function of protecting the RF was deterring the threat. Figure 44 shows the objective hierarchy for deterrence.

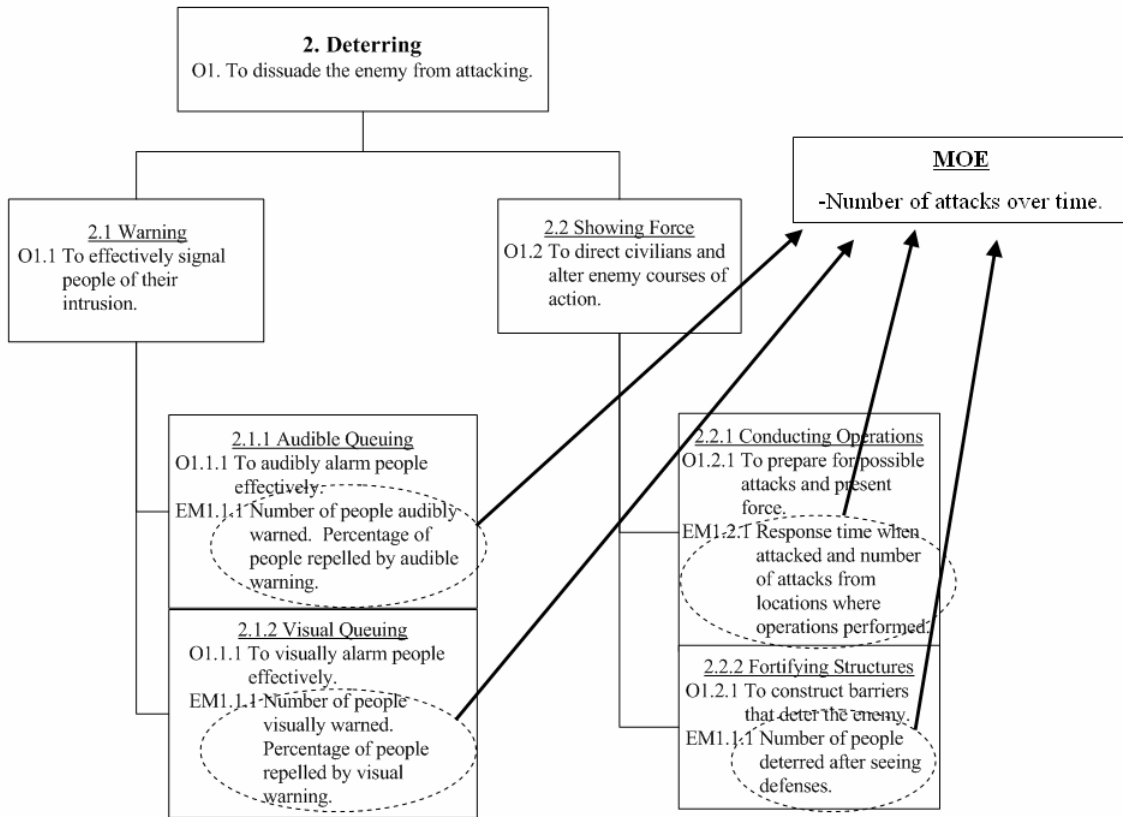

Figure 44. Deterrence Objectives Hierarchy

The objective of deterring was to dissuade the enemy from attacking because no attack translates to zero damage to the RF. The sub-functions for deterring were warning and showing force. The objective of warning was to effectively warn people of their intrusion. The RST defined an effective warning as one that is early, accurate, and results in a desired action. This way the warnings served as a filtering device between civilians and the enemy due to the assumption that civilians would not normally enter areas where they would potentially be harmed. The MOP for warning were the number of people warned and the percentage of people repelled by the warning, as applied to a visual or auditory queues. Number of people warned reflected the clarity of the warning signal

and how easily a person or group identified the warning. Percentage of people repelled measured the success of the warning at creating the desired affect. For example, the desired affect were for civilians to leave the area and for the enemy to possibly cease an attack attempt.

The next sub-function of deterring was showing force. The objective of showing force was to deter people by showing defensive capability. Although showing force was primarily directed at would-be attackers, the general civilian population was used in the objective because showing force also aims to stop civilians from entering restricted areas, in a similar fashion as the use of warnings. The sub-functions of showing force were conducting operations and fortifying structures. The objectives of conducting operations were to prepare for attacks and present force. The corresponding MOP for these objectives were: time to repel attack and number of attacks from areas where operations were conducted. Conducting operations was interpreted as the change in posture that demonstrates a certain defensive capability with the goal of altering enemy courses of action, giving the enemy less avenues to attack. The objective of fortifying structures was to prepare for attacks and demonstrate greater defensive capability. The corresponding MOP for these objectives was number of attacks on defensive positions that were increasingly fortified.

The MOE for these MOP's was number of attacks over time. The more successful the FPS was at deterrence, the less enemy attacks would occur over time. The final sub-function of protecting the RF was denying the threat. Figure 45 shows the objective hierarchy for denying.

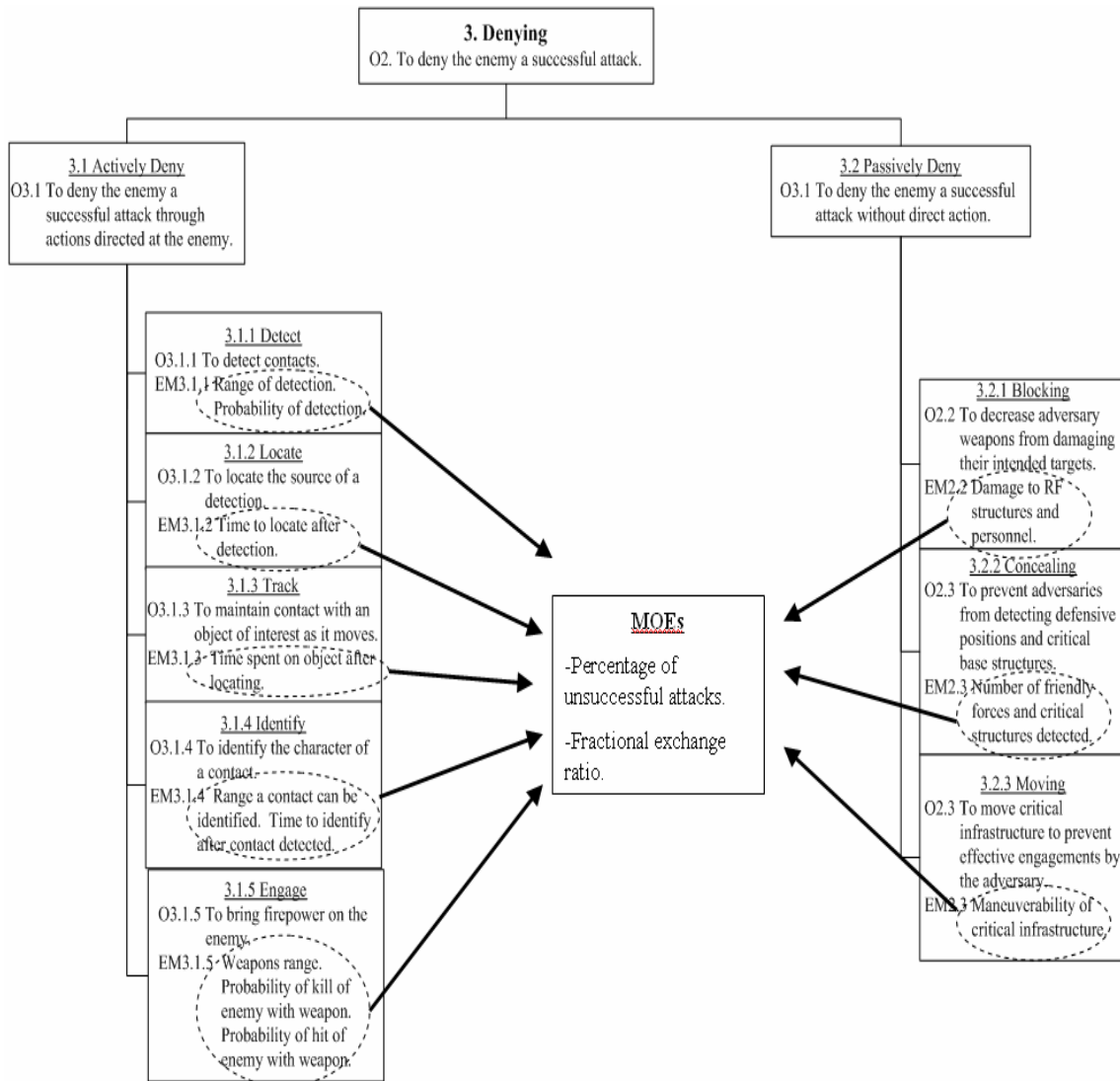

Figure 45. Denial Objectives Hierarchy

The main objective under denial was to deny the enemy a successful attack. The sub-functions of denial explained in the functional hierarchy for the FPS were actively denying and passively denying. The objective of actively denying was to deny the enemy a successful attack through actions directed at the enemy. The sub-functions of actively denying consisted of detect, locate, track, identify, and engage. The objective of detect was to detect contacts with the MOP of range of detection and probability of detection. The objective of locate was to locate the source of detection. The MOP for this objective was time to locate after detection. The objective of track was to maintain contact with an

object of interest as it moves with time spent on object after locating as the MOP. The objective of identify was to identify the character of a contact as hostile or friendly with the MOP's range a contact can be identified and time to identify after contact detected. The objective of engage was to bring firepower on the enemy with the MOP's of weapon range, probability of kill, and probability of hit.

The next sub-function of denying was passively denying. The objective of passively denying was to deny the enemy a successful attack without direct action. The sub-functions for passively denying were blocking, concealing, and moving. The objective of blocking was to decrease the adversary's weapons from damaging their intended targets. The MOP for this objective was the damage to RF structures and personnel when attacked. Number of personnel killed and injured quantified the damage to personnel while the damage to facilities can be qualitatively determined as operational or non-operational. The objective of concealing was to prevent adversaries from detecting defensive positions and critical base structures. The MOP for this objective was the number of defensive positions and critical structures detected by adversaries. The final sub-function of passively denying was moving. The objective of moving was to move critical infrastructure to prevent effective engagements by the adversary. The MOP for this objective was the maneuverability of critical infrastructure which could be measured in speed of the platform for a MOB.

The selected MOE's for the various MOP's associated with denial were the number of failed attacks and the fractional exchange ratio. The number of failed attacks was qualitatively determined based on the severity of damage proportional to the size and complexity of the enemy attack. The fractional exchange ratio, or loss of RF versus enemy forces, was used to see how well each FPS protected its most important asset, people.

Aside from the objectives, MOP's, and MOE's that relate to functions, the RST also evaluated the FPS in terms of operational suitability, or how efficient the FPS was in the operating environment. Figure 46 shows the operational suitability of the FPS.

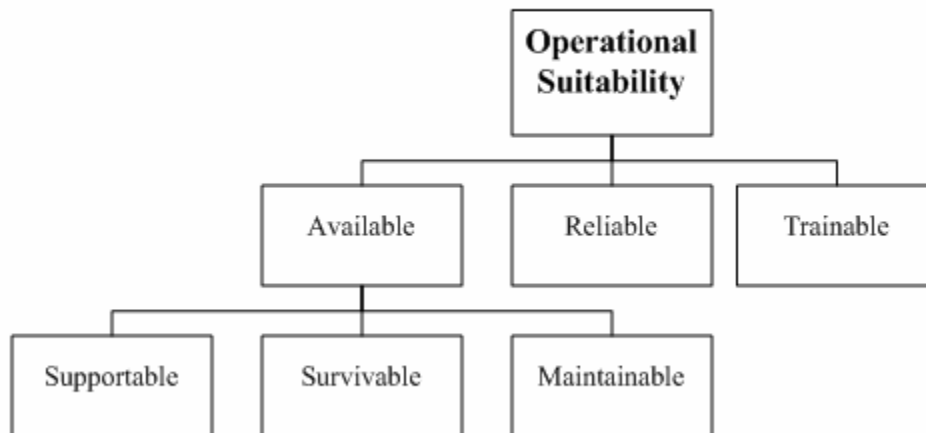

Figure 46. FPS System Suitability

Availability meant how available the various assets were for the FPS in terms of their operational readiness. The metric for availability was percentage of time a given system was operationally available. Supportability, survivability, and maintainability all played a role in overall system operational availability. The supportability considerations for the FPS related to the logistical demands of the various components. For example, people require food, water, shelter, and other materials whereas a sensor package requires some type of power source. The ease in obtaining supplies or storing supplies for these systems, measured in time to obtain supplies and shelf life, determined the supportability of a system. Survivability considered how robust the competing architectures were in the operational environment. This was measured in the number of times the system breaks as a result of the elements or enemy courses of action. Maintainability of the FPS applied to how well the sensor and weapon systems were maintained in the operating environment. Some of the higher technology sensor and weapon systems that are currently being developed, and will be deployed by 2012, might provide great capability, but also create significant maintenance challenges. The metric for maintainability was time spent in maintenance, or off-line. Reliability described how often the system performed as intended. Reliability related to weapon systems in how often they would jam, sensors in how often they failed or provided false alarms, and barriers in how often they failed or the levels of firepower different barrier systems could take. The percentage of times the

system failed performing its intended function was used as the metric for reliability. This way the reliability could apply across the different components in a FPS, such as, the percentage a weapon jams, or a sensor system breaks. Trainability considered the ease of which the RF personnel could perform the required activities to make a FPS architecture successful. The metric for trainability is time.

The suitability of the FPS was considered when the RST constructed the operational architecture, but the FPS did not conduct an analysis of the system's suitability because there are currently no requirements on how well a FPS must meet these objectives. The RST did, however, conclude that a suitable system must possess these characteristics.

This construct for the FPS also ties into the overarching analysis for the alternatives for sustainment of the RF. As it relates to the overall analysis conducted by the RST, the success of the FPS in the basing alternatives will provide a qualitative analysis of the survivability for the basing alternatives.

⁹⁵ Andrew P. Sage and James E. Armstrong Jr., *Introduction to Systems Engineering* (New York: John Wiley & Sons, 2000), 168.

⁹⁶ Eugene P. Paulo, SI4001 Systems Engineering and Architecture Course Notes; Needs Analysis, (Naval Postgraduate School, 10 July 2006), slides.

⁹⁷ Benjamin S. Blanchard and Wolter J. Fabrycky, *Systems Engineering and Analysis*, 4th ed. (Upper Saddle River, NJ: Pearson Education, 2006), 716-717.

⁹⁸ Andrew P. Sage and James E. Armstrong Jr., *Introduction to Systems Engineering* (New York: John Wiley & Sons, 2000), 101-102.

⁹⁹ Eugene P. Paulo, SI4001 Systems Engineering and Architecture Course Notes; Value System Design, (Naval Postgraduate School, 21 July 2006), slides.

¹⁰⁰ Benjamin S. Blanchard and Wolter J. Fabrycky, *Systems Engineering and Analysis*, 4th ed. (Upper Saddle River, NJ: Pearson Education, 2006), 55-56.

¹⁰¹ Wayne E Meyer Institute, Memorandum sent to authors, December 6, 2006.

¹⁰² Dennis M. Buede, *The Engineering Design of Systems: Models and Methods* (New York: John Wiley & Sons, 2000), 128-9.

¹⁰³ Benjamin S. Blanchard and Wolter J. Fabrycky, *Systems Engineering and Analysis*, 4th ed. (Upper Saddle River, NJ: Pearson Education, 2006), 3.

¹⁰⁴ Eugene P. Paulo, *SI4001 Systems Engineering and Architecture Course Notes; Needs Analysis*, (Naval Postgraduate School, 10 July 2006), slides.

¹⁰⁵ Andrew P. Sage and James E. Armstrong Jr., *Introduction to Systems Engineering* (New York: John Wiley & Sons, 2000), 128.

¹⁰⁶ Benjamin S. Blanchard and Wolter J. Fabrycky, *Systems Engineering and Analysis*, 4th ed. (Upper Saddle River, NJ: Pearson Education, 2006), 4.

¹⁰⁷ Eugene P. Paulo, *SI4001 Systems Engineering and Architecture Course Notes; Needs Analysis*, (Naval Postgraduate School, 10 July 2006), slides.

¹⁰⁸ Naval Expeditionary Combat Command, *U. S. Navy Riverine Group, Concept of Operations*, 28 September 2006 (Little Creek, VA: GPO, 2006), 17.

¹⁰⁹ Naval Expeditionary Combat Command, *U. S. Navy Riverine Group, Concept of Operations*, 28 September 2006 (Little Creek, VA: GPO, 17).

¹¹⁰ U.S. Department of the Army, *Logistics Manual (ALM) 43-4302-C Overview of Army Maintenance Management*, 2004 (Washington, DC: GPO, 2004), 199-210.

¹¹¹ U.S. Department of the Navy, *Marine Corps Warfighting Publication (MCWP) 4-11.4 Maintenance Operations*, 24 April 1998 (Washington, DC: GPO, 1998), 1-14.

¹¹² U.S. Department of Defense, *Joint Publication 1-02: Department of Defense Dictionary of Military and Associated Terms*, 1 March 2007 (Washington, D.C.: GPO, 12 April 2001), 157.

¹¹³ *Dictionary.com*, s.v. “deny,” <http://dictionary.reference.com/browse/deny> (accessed: 02 April 2007).

¹¹⁴ Captain David Balk, in discussion with the authors, 29 March 2007.

¹¹⁵ CWO3 Rod Smith, Riverine One Command Brief, (18th Navy Counselor Symposium, July 12, 2006), slides.

¹¹⁶ Andrew P. Sage and James E. Armstrong Jr., *Introduction to Systems Engineering* (New York: John Wiley & Sons, 2000), 101.

¹¹⁷ Eugene P. Paulo, *SI4001 Systems Engineering and Architecture Course Notes; Needs Analysis*, (Naval Postgraduate School, 10 July 2006), slides.

¹¹⁸ Andrew P. Sage and James E. Armstrong Jr., *Introduction to Systems Engineering* (New York: John Wiley & Sons, 2000), 102-103.

¹¹⁹ U.S. Department of Defense, *Joint Publication 1-02: Department of Defense Dictionary of Military and Associated Term*, 1 March 2007 (Washington, DC: GPO, 12 April 2001), 477.

¹²⁰ Andrew P. Sage and James E. Armstrong, Jr., *Introduction to Systems Engineering* (New York: Wiley, 2000)

¹²¹ Christopher M. Adams, “Inventory Optimization Techniques, System vs. Item Level Inventory Analysis.” Reliability and Maintainability Symposium (RAMS), (2004): 55-60.

¹²² Department of the Army, Technical Manual (TM) 5-698-2, *Reliability-Centered Maintenance (RCM) for Command, Control, Communications, Computer, Intelligence, Surveillance and Reconnaissance (C4ISR) Facilities*, 2003 (Washington, DC). 1-1.

¹²³ Christopher M. Adams, “Inventory Optimization Techniques, System vs. Item Level Inventory Analysis.” Reliability and Maintainability Symposium (RAMS), (2004): 55-60.

¹²⁴ Dennis M. Buede, *The Engineering Design of Systems: Models and Methods* (New York: John Wiley & Sons, 2000), 182.

¹²⁵ U.S. Department of Defense, *Joint Publication 1-02: Department of Defense Dictionary of Military and Associated Terms*, 1 March 2007 (Washington, D.C.: GPO, 12 April 2001), 184.

¹²⁶ U.S. Department of Defense, *Joint Publication 1-02: Department of Defense Dictionary of Military and Associated Terms*, 1 March 2007 (Washington, D.C.: GPO, 12 April 2001), 76.

¹²⁷ U.S. Department of Defense, *Joint Publication 1-02: Department of Defense Dictionary of Military and Associated Terms*, 1 March 2007 (Washington, D.C.: GPO, 12 April 2001), 154.

¹²⁸ U.S. Department of Defense, *Joint Publication 1-02: Department of Defense Dictionary of Military and Associated Terms*, 1 March 2007 (Washington, D.C.: GPO, 12 April 2001), 101.

¹²⁹ U.S. Department of Defense, *Joint Publication 1-02: Department of Defense Dictionary of Military and Associated Terms*, 1 March 2007 (Washington, D.C.: GPO, 12 April 2001), 522.

¹³⁰ U.S. Department of Defense, *Joint Publication 1-02: Department of Defense Dictionary of Military and Associated Terms*, 1 March 2007 (Washington, D.C.: GPO, 12 April 2001), 164.

¹³¹ U.S. Department of Defense, *Joint Publication 1-02: Department of Defense Dictionary of Military and Associated Terms*, 1 March 2007 (Washington, D.C.: GPO, 12 April 2001), 370.

¹³² U.S. Department of Defense, *Joint Publication 1-02: Department of Defense Dictionary of Military and Associated Terms*, 1 March 2007 (Washington, D.C.: GPO, 12 April 2001), 221.

¹³³ U.S. Department of Defense, *Joint Publication 1-02: Department of Defense Dictionary of Military and Associated Terms*, 1 March 2007 (Washington, D.C.: GPO, 12 April 2001), 448.

¹³⁴ U.S. Department of Defense, *Joint Publication 1-02: Department of Defense Dictionary of Military and Associated Terms*, 1 March 2007 (Washington, D.C.: GPO, 12 April 2001), 89.

¹³⁵ U.S. Department of Defense, *Joint Publication 1-02: Department of Defense Dictionary of Military and Associated Terms*, 1 March 2007 (Washington, D.C.: GPO, 12 April 2001), 458.

¹³⁶ U.S. Department of Defense, *Joint Publication 1-02: Department of Defense Dictionary of Military and Associated Terms*, 1 March 2007 (Washington, D.C.: GPO, 12 April 2001), 510.

¹³⁷ U.S. Department of Defense, *Joint Publication 1-02: Department of Defense Dictionary of Military and Associated Terms*, 1 March 2007 (Washington, D.C.: GPO, 12 April 2001), 89.

¹³⁸ U.S. Department of Defense, *Joint Publication 1-02: Department of Defense Dictionary of Military and Associated Terms*, 1 March 2007 (Washington, D.C.: GPO, 12 April 2001), 279 and 505.

¹³⁹ U.S. Department of Defense, *Joint Publication 1-02: Department of Defense Dictionary of Military and Associated Terms*, 1 March 2007 (Washington, D.C.: GPO, 12 April 2001), 421.

¹⁴⁰ U.S. Department of Defense, *Joint Publication 1-02: Department of Defense Dictionary of Military and Associated Terms*, 1 March 2007 (Washington, D.C.: GPO, 12 April 2001), 109.

¹⁴¹ U.S. Department of Defense, *Joint Publication 1-02: Department of Defense Dictionary of Military and Associated Terms*, 1 March 2007 (Washington, D.C.: GPO, 12 April 2001), 115.

¹⁴² U.S. Department of Defense, *Joint Publication 1-02: Department of Defense Dictionary of Military and Associated Terms*, 1 March 2007 (Washington, D.C.: GPO, 12 April 2001), 517 and 312.

¹⁴³ U.S. Department of Defense, *Joint Publication 1-02: Department of Defense Dictionary of Military and Associated Terms*, 1 March 2007 (Washington, D.C.: GPO, 12 April 2001), 431.

¹⁴⁴ U.S. Department of Defense, *Joint Publication 1-02: Department of Defense Dictionary of Military and Associated Terms*, 1 March 2007 (Washington, D.C.: GPO, 12 April 2001), 146.

¹⁴⁵ U.S. Department of Defense, *Joint Publication 1-02: Department of Defense Dictionary of Military and Associated Terms*, 1 March 2007 (Washington, D.C.: GPO, 12 April 2001), 354.

¹⁴⁶ U.S. Department of Defense, *Joint Publication 1-02: Department of Defense Dictionary of Military and Associated Terms*, 1 March 2007 (Washington, D.C.: GPO, 12 April 2001), 313 and 179.

¹⁴⁷ U.S. Department of Defense, *Joint Publication 1-02: Department of Defense Dictionary of Military and Associated Terms*, 1 March 2007 (Washington, D.C.: GPO, 12 April 2001), 505.

¹⁴⁸ U.S. Department of Defense, *Joint Publication 1-02: Department of Defense Dictionary of Military and Associated Terms*, 1 March 2007 (Washington, D.C.: GPO, 12 April 2001), 510

¹⁴⁹ U.S. Department of Defense, *Joint Publication 1-02: Department of Defense Dictionary of Military and Associated Terms*, 1 March 2007 (Washington, D.C.: GPO, 12 April 2001), 510.

¹⁵⁰ U.S. Department of Defense, *Joint Publication 1-02: Department of Defense Dictionary of Military and Associated Terms*, 1 March 2007 (Washington, D.C.: GPO, 12 April 2001), 510.

¹⁵¹ U.S. Department of Defense, *Joint Publication 1-02: Department of Defense Dictionary of Military and Associated Terms*, 1 March 2007 (Washington, D.C.: GPO, 12 April 2001), 505.

¹⁵² U.S. Department of Defense, *Joint Publication 1-02: Department of Defense Dictionary of Military and Associated Terms*, 1 March 2007 (Washington, D.C.: GPO, 12 April 2001), 79 and 78.

¹⁵³ U.S. Department of Defense, *Joint Publication 1-02: Department of Defense Dictionary of Military and Associated Terms*, 1 March 2007 (Washington, D.C.: GPO, 12 April 2001), 79.

¹⁵⁴ U.S. Department of Defense, *Joint Publication 1-02: Department of Defense Dictionary of Military and Associated Terms*, 1 March 2007 (Washington, D.C.: GPO, 12 April 2001), 503.

¹⁵⁵ U.S. Department of Defense, *Joint Publication 1-02: Department of Defense Dictionary of Military and Associated Terms*, 1 March 2007 (Washington, D.C.: GPO, 12 April 2001), 404 and 187.

¹⁵⁶ U.S. Department of Defense, *Joint Publication 1-02: Department of Defense Dictionary of Military and Associated Terms*, 1 March 2007 (Washington, D.C.: GPO, 12 April 2001), 243.

¹⁵⁷ U.S. Department of Defense, *Joint Publication 1-02: Department of Defense Dictionary of Military and Associated Terms*, 1 March 2007 (Washington, D.C.: GPO, 12 April 2001), 510.

¹⁵⁸ U.S. Department of Defense, *Joint Publication 1-02: Department of Defense Dictionary of Military and Associated Terms*, 1 March 2007 (Washington, D.C.: GPO, 12 April 2001), 463.

¹⁵⁹ U.S. Department of the Navy, *Marine Corps Warfighting Publication (MCWP) 4-11.4 Maintenance Operations*, 24 April 1998 (Washington, DC: GPO, 1998), 2-10.

¹⁶⁰ U.S. Department of Defense, *Joint Publication 1-02: Department of Defense Dictionary of Military and Associated Terms*, 1 March 2007 (Washington, D.C.: GPO, 12 April 2001), 157.

¹⁶¹ U.S. Department of Defense, *Joint Publication 1-02: Department of Defense Dictionary of Military and Associated Terms*, 1 March 2007 (Washington, D.C.: GPO, 12 April 2001), 549.

¹⁶² U.S. Department of Defense, *Joint Publication 1-02: Department of Defense Dictionary of Military and Associated Terms*, 1 March 2007 (Washington, D.C.: GPO, 12 April 2001), 249.

¹⁶³ U.S. Department of Defense, *Joint Publication 1-02: Department of Defense Dictionary of Military and Associated Terms*, 1 March 2007 (Washington, D.C.: GPO, 12 April 2001), 184.

¹⁶⁴ Benjamin S. Blanchard and Wolter J. Fabrycky, *Systems Engineering and Analysis*, 4th ed. (Upper Saddle River, NJ: Pearson Education, 2006), 716.

¹⁶⁵ Benjamin S. Blanchard and Wolter J. Fabrycky, *Systems Engineering and Analysis*, 4th ed. (Upper Saddle River, NJ: Pearson Education, 2006), 717.

¹⁶⁶ Benjamin S. Blanchard and Wolter J. Fabrycky, *Systems Engineering and Analysis*, 4th ed. (Upper Saddle River, NJ: Pearson Education, 2006), 717.

¹⁶⁷ Dennis M. Buede, *The Engineering Design of Systems: Models and Methods* (New York: John Wiley & Sons, 2000), 341.

¹⁶⁸ James E. Gibson, “How to Do Systems Analysis” (paper, University of Virginia: Charlottesville, Virginia, 1991), 55-58.

¹⁶⁹ Dennis M. Buede, *The Engineering Design of Systems: Models and Methods*, (New York, NY: John Wiley & Sons, Inc., 2000), 147.

¹⁷⁰ “SURC Failure Reporting Analysis and Corrective Action System (FRACAS) Information,” *Raytheon Technical Services, Customer Logistics Support (CLS) Quarterly Report*, (26 March 2007).

¹⁷¹ U.S. Department of Defense, *Joint Publication 1-02: Department of Defense Dictionary of Military and Associated Terms*, 1 March 2007 (Washington, D.C.: GPO, 12 April 2001), 208.

THIS PAGE INTENTIONALLY LEFT BLANK

4. PHYSICAL ARCHITECTURE

4.1 PHYSICAL ARCHITECTURE COMPONENTS AND PURPOSE

The physical architecture of a system is a hierarchical description of the resources that comprise the system. This hierarchy begins with the system and the system's top-level components and progresses down to the configuration items (CIs) that comprise each intermediate component. The CIs can be hardware or software elements or combinations of hardware and software, people, facilities, procedures, and documents (e.g. user's manuals).¹⁷²

The purpose of developing a physical architecture is a "belief that the operational architecture development is predicated on having a variety of interesting physical architectures to match with the functional architecture. Therefore, the primary product of this function for designing the physical architecture is a reasonable number of interesting physical architectures that can be combined with the functional architecture and evaluated to determine their effectiveness in meeting the objectives established in the requirements."¹⁷³

These "interesting physical architectures" were developed in parallel with the functional architectures discussed in Chapter Three of this report. This chapter is therefore focused on developing and analyzing the alternatives that enable the functional and physical architectures of the various systems examined by the RST and are summarized in a morphological chart. "A complete and all-inclusive alternative rarely emerges in its final state. It begins as a hazy but interesting idea."¹⁷⁴ The RST generated a list of possible alternatives that may be able to perform the functions and objectives for overall RF sustainment. Although some alternatives had little likelihood of being feasible, the "idea is that it is better to consider many alternatives than to overlook one that might be preferred."¹⁷⁵ These alternatives were subjected to a feasibility analyses and risk analyses.

Feasibility analysis is essentially narrowing down the number of alternatives to a few feasible ones, consistent with the schedule requirements and available resources.¹⁷⁶ "All proposed alternatives are not necessarily attainable."¹⁷⁷ They are considered in

order to prevent overlooking alternatives that might be preferred.¹⁷⁸ After generating a list of alternatives, the RST did further research and eliminated alternatives that were deemed infeasible due to specific capabilities and requirements. Further analysis was only conducted on the feasible alternatives that performed the required functions and met the overall system requirements.

Risk is the “probability and severity of loss linked to hazards.”¹⁷⁹ “Risk analysis is accomplished to determine the way(s) in which the risk can be eliminated, or minimized if not eliminated altogether.”¹⁸⁰ The different alternatives that the RST generated each had risk. The RST examined these risks in order to be aware of possible limitations of each alternative. The RST also sought ways to mitigate these risks. Risk analysis included technical risk, cost risk, schedule risk, and programmatic risk. Technical risk is “the possibility that a technical requirement of the system will not be achieved.”¹⁸¹ Cost risk is “the possibility that a specified allocated budget will be exceeded”¹⁸² and was examined and used in this study as a means of comparison between alternative architectures. Schedule risk is “the possibility that a project will fail to meet the scheduled milestones”¹⁸³ which in this study was limited to systems that could be deployed by 2012. Programmatic risks are “the occurrence of events, imposed on the program/project which are the result of external influences.”¹⁸⁴ Programmatic risks are not discussed in this report.

4.2 NAVAL EXPEDITIONARY COMMAND ELEMENTS

The Navy established NECC in January 2006 to serve as a single functional command to centrally manage the current and future readiness, resources, manning, training, and equipping of the Navy Expeditionary Force. NECC’s primary role is to provide combat-ready units across the full range of joint and service specific expeditionary missions to the JFMCC/Navy Component Commanders (NCC’s). These expeditionary capabilities provided by the NECC Force includes Naval Coastal Warfare (NCW), Explosive Ordnance Disposal (EOD), Mobile Diving and Salvage (MDS), expeditionary logistics, expeditionary engineering and construction, riverine, maritime expeditionary security, maritime civil affairs, expeditionary training, and Expeditionary Combat Readiness Center (ECRC).

Based on operational requirements, NECC will deploy mission-specific units or multi-mission integrated adaptive force packages to fulfill JFMCC/NCC demands by using an existing solid foundation of core capabilities in the Navy Expeditionary Force and emerging new mission capabilities. Combining these forces under a unified command structure increases the overall readiness and responsiveness of the Navy to support existing and evolving irregular warfare missions in major combat operations (MCO), MSO, or maritime homeland security/defense.¹⁸⁵

In Figure 47, the basic functions and capabilities are broken out across the board for the NECC Force. The capabilities listed in black exist in today’s NECC and the ones in red are capabilities to be fielded in the near future.

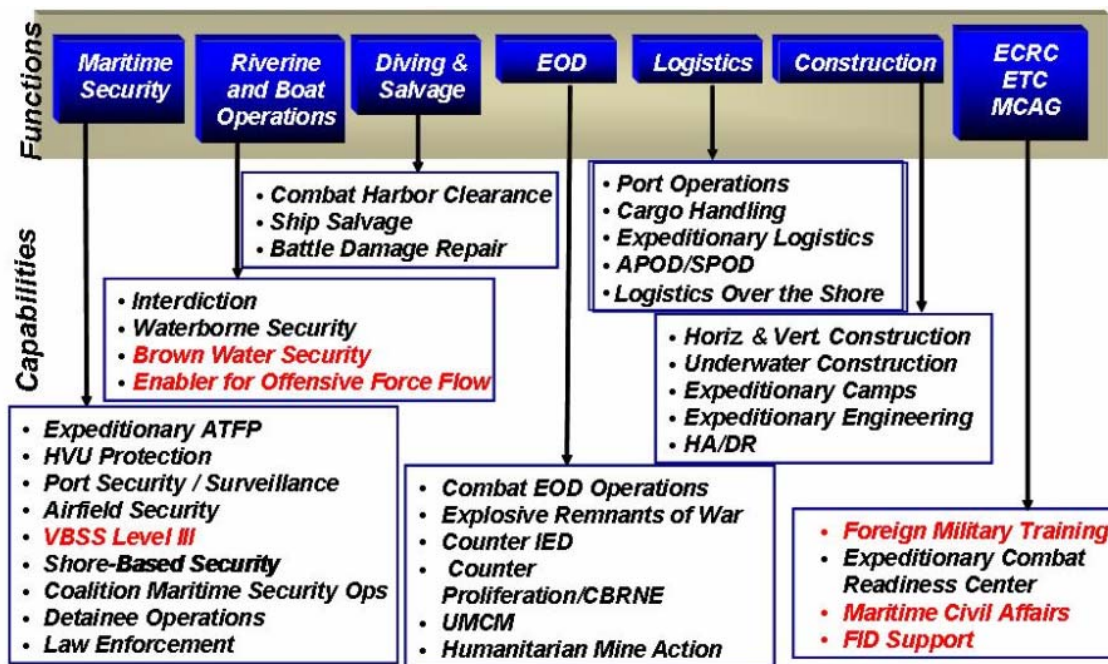

Figure 47. NECC Functions and Capabilities¹⁸⁶

“The NECC Force delivers unique skill sets to MSO to ensure access across the maritime operational environment. Expeditionary effects-based operations solidify access by influencing an enemy to perform in a desired way or by denying an enemy’s ability to use asymmetric engagements to disrupt naval and joint forces in an expeditionary environment. By supporting expeditionary effects-based operations, the NECC Force provides the following unique and essential contributions to MSO:

- Secures the assigned operational environment for the flow of the joint forces and logistics from the sea base to ashore.
- Expands the JFMCC/NCC area of influence and situational awareness in the green and brown water environments.
- Provides tools to enhance TSC activities.
- Support of the 1,000 ship Navy concept improves relationships with and access for countries that lack traditional navies.
- Improves the ability of the United States and partner nations to deny terrorist activity, stem piracy, and interdict the flow of illegal arms, drugs, and human trafficking.
- Optimizes the interdependency with Naval Special Warfare, U. S. Coast Guard, and U. S. Marine Corps in the shared expeditionary environment.”¹⁸⁷

Figure 48 illustrates how a NECC full-spectrum adaptive force package would lay-out in a JFMCC environment.



Figure 48. NECC Support of the JFMCC Environment¹⁸⁸

The following list comprises the NECC Elements represented in Figure 48 and what types of mission they perform in the green/brown water environment.

- EOD forces detect, locate, and dispose of unexploded ordnance.
- Diving and salvage operations are done by MDS teams.
- The MESF provide expeditionary security ashore and afloat.
- Expeditionary Engineering is conducted by the NCF.
- Expeditionary Logistics Support (cargo handling, support and customs) is handled by the Navy Expeditionary Logistics Support Forces (NELSF).
- The RF conducts MSO and TSC operations in the riparian environment.
- Maritime Civil Affairs Group (MCAG) conducts the hearts and minds campaign
- Expeditionary Training Command (ETC) trains foreign partners in any of the aforementioned disciplines.

These commands and several other smaller support elements comprise the NECC Fore Structure.

4.3 RIVERINE SQUADRON ELEMENTS

The riverine squadron contains a variety of elements to provide a capable, baseline force. When this baseline force is not deemed capable enough to meet the various demands of the operational environment, the squadron is augmented with other elements from the NECC. Without any of these augments, the squadron is comprised of 224 personnel divided into three detachments.

The command element is in charge of the tactical operations center (TOC)/planning cell as well as carrying out the squadron's administrative duties. To accomplish both of these tasks, the command element has 23 personnel consisting of four administrative personnel, four intelligence personnel, six operations/planning personnel, six C4I personnel, and the commanding and executive officer.¹⁸⁹ Operating the TOC enables the command element to control the squadron and is the command element's

most important function. The TOC relays vital information in the form of voice and data transmissions throughout the RF, to coalition forces, and to higher headquarters.¹⁹⁰ The TOC also contains all the relevant information about the operational area including maps of the battlespace with the location of coalition units and displays current intelligence reports.¹⁹¹ Aside from the four administrative personnel, the 19 people assigned to the TOC must establish a watch schedule to operate the TOC 24 hours a day.

The mission element consists of 159 personnel and contains three detachments.¹⁹² Each detachment is comprised of a three person command team, a two person medical support team, an eight person boarding team, and four boats manned by two crews of five personnel. The mission element, therefore, has under its control twelve SURC's designed to carry out a vast array of missions.

The supporting element contains 42 personnel and is responsible for the maintenance, logistics, force protection, training, medical support, and combat service support for the squadron. For maintenance there are nine mechanics for the SURC's and rolling gear.¹⁹³ These mechanics must have the equipment and facilities "to conduct routine and combat related maintenance."¹⁹⁴ For logistics, there are four personnel responsible for restocking the squadron's supplies as well as monitoring the level of supplies. The squadron has 17 force protection personnel to provide security for the operating base and protection for the mission element when operating close to the base.¹⁹⁵ The training cell has three personnel assigned to ensure RS personnel have achieved the necessary training and qualifications. The medical support has eight corpsmen, two corpsmen responsible for the base of operations and two corpsmen deploying with each detachment within the mission element. Finally, there are seven personnel assigned to the combat service support element with the primary function of motor transport support.¹⁹⁶

4.4 ADAPTIVE FORCE PACKAGES

The adaptive force package concept is a new concept that has not been clearly defined. The RST developed a definition for adaptive force packages that will encompass and define this term to its fullest extent. Adaptive force packages are

“tailorable force modules”¹⁹⁷ which will allow for “rapid, land, sea, air and battlespace dominance”¹⁹⁸. Tailorable force modules enable the commander to tailor a force structure to meet the requirements of the operation while minimizing force size. This decrease in force size is offset by increased capabilities through the application of new technologies.¹⁹⁹ These smaller forces result in “reduced O&S cost, reduced logistics tail, and will allow for the faster application on new technology.”²⁰⁰ The RST defined adaptive force packages as the right size force with the correct mix of skill sets to effectively conduct an operation.

4.5 BASING ALTERNATIVES

4.5.1 Forward Operating Base

The RF may perform a multitude of missions which may require various adaptive force packages. Therefore, it is necessary the FOB be an easily scalable, rapidly deployable structure able to accommodate fluctuations in personnel, facilities, and equipment. In this scenario the RST recognized that the RF required additional capabilities from various detachments within the NECC including EOD, UAV, MESF, civil affairs, and linguists. A small element of host nation forces, in this case the Indonesian Army, would also be present with the RF to provide coordination and conduct training. The RST reasoned that the total additional personnel from these augments would be around 125 people, bringing the total number of personnel for the RF in this scenario to approximately 350. The RST also determined for this scenario that the RF would be best supported from a single base containing all of the riverine squadrons’ elements. The FOB, therefore, had to provide all of the functions of a squadrons’ support base such as “command oversight, planning, staging, logistics and maintenance”²⁰¹ in addition to the requirement for each detachment of the mission element and the augmented detachments.

The RST leveraged the existing Navy Construction Battalion (Seabees) automated tent camp architecture to design an FOB for the RST. The facilities that comprise the Seabee’s tent camps are already in use today and they can be constructed rapidly and are easily configurable with other augments within NECC. The Seabees designed four

camps for the RF. Three of the camps are identical and were created to support a detachment. The other camp was designed to support the command and supporting elements that comprise the RF, serving as the support base. This way, the RF could conduct distributed operations along a river if required. The four camps all contain identical facilities and can be configured in different combinations as desired. In addition to the riverine squadron, most of the other augments within the NECC also have tent camp designs. This made FOB planning from the entire RF easier because the augmented forces' structures are similar to the riverine squadron. Figure 49 is an illustration of how the tent camps were combined for the FOB in this scenario.

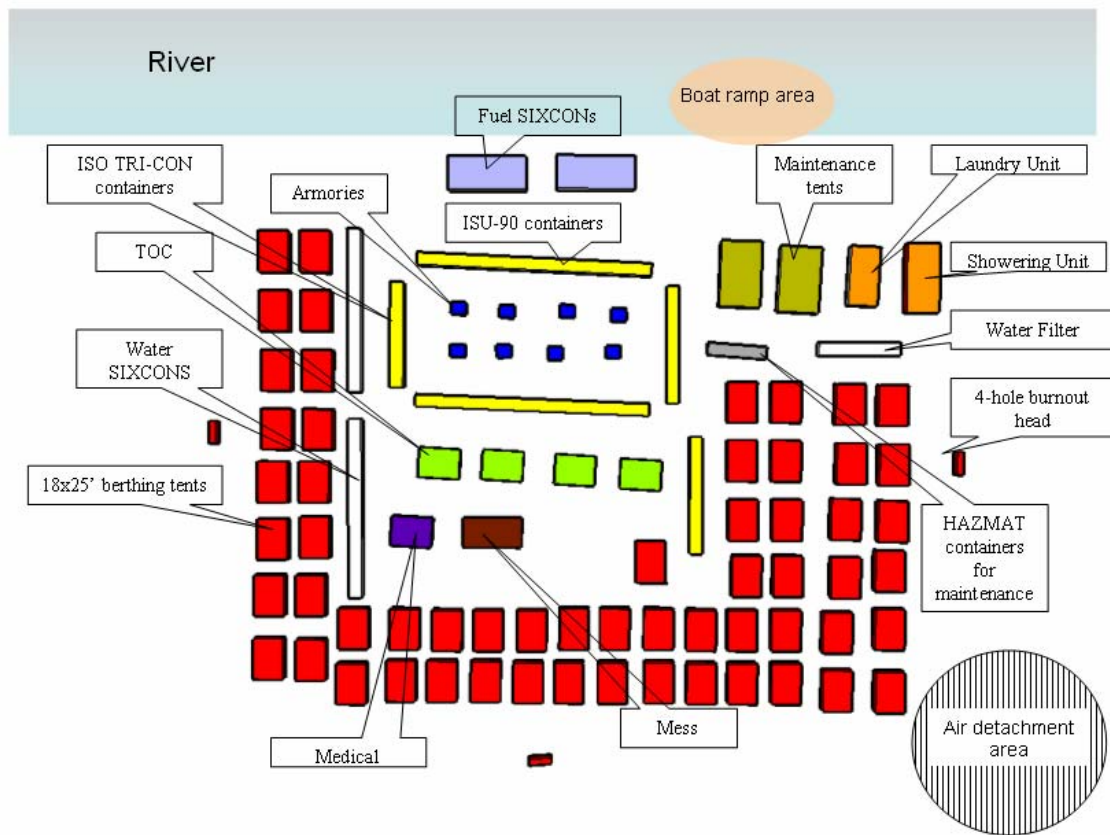

Figure 49. Forward Operating Base Configuration

This model was built using Google Sketch, so that every building could be drawn to scale and uploaded to the operational environment in Google Earth. This base is just one of many configurations possible, with the understanding that configuration changes are based on the preferences of a squadrons' commanding officer.²⁰²

The camp was configured with considerations for force protection and convenience of conducting operations. The majority of the structures located in the FOB are berthing tents for the RF personnel. These tents hold approximately six people each and are 18 feet wide and 25 feet long.²⁰³ The model here shows a configuration of 59 tents for a total of 354 people on the FOB. The berthing tents were placed in a horse shoe pattern around the perimeter of the base to conceal critical facilities and facilitate a faster response by the resting personnel to the perimeter if a major attack on the FOB occurred.

At the center of the FOB are the TOC's. These are the most critical structures to the RF and were placed in the center of the FOB to provide maximum concealment and protection. The TOC is constructed with the same tent used for berthing, but reinforced with sandbags to increase survivability. One of these tents would be designated as the TOC for the planning cell while the other three can serve as mission planning areas for the three detachments. The TOC is the major consumer of power for the RF. The current power source for the RF is a trailer of two 30 KW generators, however the RST decided that two 60 KW generators would provide the necessary power for the added facilities.

For the general storage of non-hazardous material such as food, clothing, and other supplies, the RF uses 10 ISO TRI- CON four-door containers and 48 ISU-90CS four-door containers. The ISU-90CS is nine feet wide, seven feet and four inches long, and seven feet and seven inches high²⁰⁴ while the ISO TRI-CON is eight feet wide, six feet and five and one-half inches long, and eight feet high. These structures were placed around the armories and to the right of the TOC's to conceal and protect these facilities. To protect the left side of the TOC, medical, and mess tents, the RST placed some of the water structures required for the RF. The two structures represent a configuration of 63 900 gallon SIXCON's to hold the water used for drinking, cooking, hygiene, and medical purposes. The SIXCON containers are generally configured in groups of six that are eight feet wide, twenty feet long, and eight feet high, the dimensions of one 900 gallon module is six feet, six inches wide, eight feet long, and 4 feet high.²⁰⁵

To decrease the amount of water shipped into the FOB, the RST also included the Tactical Water Purification System (TWPS) to provide water for maintenance, shower, and laundering purposes. The RST assumed filtered river water would be suitable for

these purposes, but did not want to risk using river water for the other purposes due to the agricultural and paper mill contamination that are located in close proximity to the FOB along the river. The TWPS can cycle through 1500 gallons of water per hour, and, through its use of reverse osmosis and micro-filtration technologies, can filter brackish water.²⁰⁶

The maintenance tents used by the squadron were located along the river and near the boat launching and recovery area to decrease the amount of time to transport the SURC's in and out of the water. These tents are 25 feet wide and 40 feet long²⁰⁷ and provide the space where maintenance can be conducted on the RF's rolling gear and SURC's. Space was provided between these tents and the shore line to ease the movement of rolling in and out of the maintenance tents. The five modified ISU-90 containers used to store lubricants and other hazardous material related to maintenance were also located near the maintenance tents for convenience.

The fuel for the RF is contained in 72 SIXCON containers which were located near the river to ease in the refueling of the SURC's. These containers were configured in modules of 36 SIXCON's and would be reinforced by berms to protect them from a potential attack from the river. The other sensitive storage structures are the armories, which were surrounded on all sides by the general storage container to protect them from assault, and the rest of the squadron if they were to detonate. The armories used by the RF are modified ISU-90 containers. Five of these containers are used to store the weapons and ammunition of the RF and the other three are outfitted for EOD material.

To increase the sanitation and quality of life at the FOB, the RST added a laundry and showering facility and three four stall heads. The laundry and showering facilities are located close to the maintenance facility because of their shared water supply while the heads were placed around the perimeter of the base for sanitation reasons.

The power for the FOB was supplied by 3 60 KW generators that could be distributed throughout the base. These generators are not depicted, but the main power consumers of the FOB are the TOC's and the TWPS, so these generators would be

located near these facilities. These generators would also be configured with a single SIXCON container to provide 900 gallons of fuel storage.

The perimeter defenses were not included in this model of the FOB because they will be analyzed as a part of the FPS.

4.5.2 Mobile Operating Base

The MOB has all the capabilities of the FOB, but is afloat on the river. As stated earlier, the support functions include operational support, medical support, logistics, helicopter support, maintenance, administration, and salvage.²⁰⁸ In order to determine what the MOB would be comprised of, the RST generated a list of possible alternatives. Afterwards, the RST performed research in order to decide which alternative was feasible for further analysis. Finally, the RST examined the risks that existed with each feasible alternative.

4.5.2.1 Analysis of Alternatives

The RST considered the functions of force protection, supply/logistics, and maintenance when generating a list of possible MOB's capable of supporting and sustaining the RF. The list of alternatives was compiled after discussions with stakeholders and research was performed in this area. The following is a list of possible platforms that have the potential of being a MOB or part of a MOB.

Littoral Combat Ship (LCS)

The LCS is “a focused mission ship designed to optimize warfighting in the Littoral Battlespace.”²⁰⁹ There are two designs for the LCS: a Lockheed Martin design and a General Dynamics design. Figure 50 is the LCS design by Lockheed Martin.



Figure 50. Lockheed Martin LCS²¹⁰

The Lockheed Martin LCS is a monohull vessel which has a length 378.3 ft, a beam of 57.4 ft, a 13.5 ft draft, and a max speed greater than 40 knots. It has both a stern ramp and side door to launch and recover small boats. It also has a universal 3-axis overhead crane system for positive control movement of off-board vehicles. The Lockheed Martin LCS has various defense systems such as a 3D air search radar, EO/IR gunfire control system, and decoy launching system. It can also launch Rolling Airframe Missiles, and it is equipped with medium caliber guns. The modular weapon zone in the Lockheed Martin LCS accommodates a variety of other offensive and defensive weapons. The Lockheed Martin LCS has a larger hangar and flight deck than current surface combatants, and it can carry two H-60 helicopters and multiple UAV's.²¹¹

The General Dynamics LCS has a completely different design than the Lockheed Martin LCS. It is a trimaran rather than a monohull. Figure 51 is the LCS by General Dynamics.

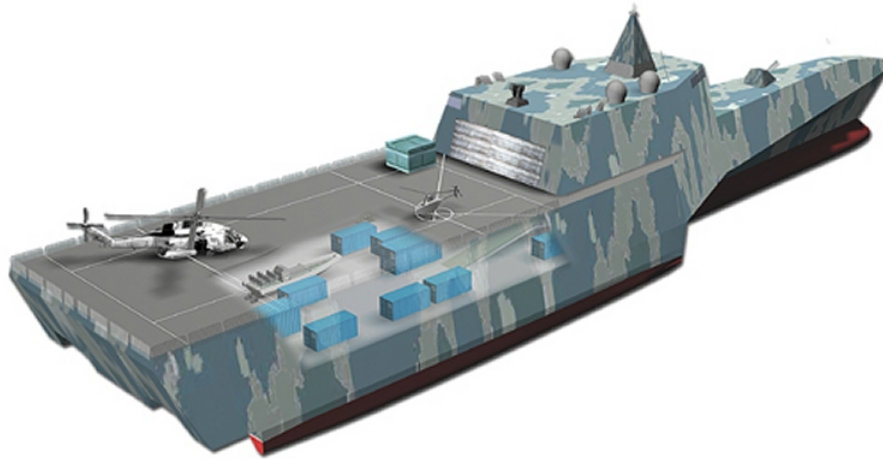

Figure 51. General Dynamics LCS.²¹²

The General Dynamics LCS has a length of 416 ft, a beam of 99 ft, a 14.4 ft draft, and a max speed greater than 40 knots. It has a stern door and crane to launch and recover small boats. The General Dynamics LCS is capable of carrying various offensive and defensive systems such as a multi-function phased array radar, towed array sonar, mine detection sonar, close-in weapon system, medium caliber guns, vertical launch system, anti-ship missile launchers, and anti-submarine torpedo tubes. Just like the Lockheed Martin LCS, the General Dynamics design has a larger hangar and flight deck than current surface combatants. It can carry two H-60 helicopters and multiple UAV's.²¹³

High Speed Vessel (HSV)

High Speed Vessel (HSV)-2 Swift is a high-speed catamaran that “will be used to develop concepts, capabilities and reconfigurable mission modules for multiple mission areas in support of LCS program development.”²¹⁴ Figure 52 is the HSV-2 Swift.



Figure 52. HSV²¹⁵

The HSV has a length of 321.5 ft, a beam of 88.6 ft, an 11.25 ft draft when loaded, and a max speed greater than 45 knots. It has a stern ramp and crane to launch and recover small boats. The large hangar can carry land and sea vehicles. The HSV is capable of carrying multiple armaments such as the MK 96 Stabilized Gun, MK 45 Snake Eyes, and MK19 Grenade Machine Gun. It also has an aft flight deck to launch and recover UAV's and helicopters.²¹⁶

Logistic Support Vessel (LSV)

Logistic Support Vessel (LSV)-1 Frank S. Besson Class is currently in service with the U.S. Army and the Philippine Navy. The LSV is capable of transporting cargo to shallow terminal areas, under-developed coastlines, and inland waterways. Figure 53 is the LSV.²¹⁷



Figure 53. Logistic Support Vessel (LSV)²¹⁸

The LSV has a length of 272 ft, a beam of 60 ft, a 12 ft draft, and a max speed of 11.6 knots. There are optional configurations to include the helicopter variant, semi-submersible variant, and the troop carrier variant. The helicopter capable variant deploys and retrieves helicopters and patrol boats. Helicopters are concealed below a modular flight deck while patrol boats are concealed behind the stern ramp. The semi-submersible variant takes on boats for transport, repair, and launch. Finally, the troop carrier variant provides berthing for 150 troops.²¹⁹

Riverine Combat Support Ship (RCSS)

The RCSS concept was developed by naval officers enrolled in the MIT Department of Mechanical Engineering. The plan was to convert an LST-1179 Newport Class tank landing ship to a craft that supports the RF. Changes were made to include providing greater fuel and ammunition capacities for small boats, providing Intermediate Maintenance Activity (IMA), establishing a Joint Operating Center (JOC), and increasing the combatant craft support capacity.²²⁰ Figure 54 is the RCSS.



Figure 54. The RCSS²²¹

The RCSS has a length of 522 ft, a beam of 69 ft, a 19.8 ft draft, and a max speed greater than 20 knots. The LST's original stern gate and causeway equipment provide enough moorage capacity for 20 combatant crafts. The RCSS will also have portside doors to access floating causeways. The RCSS has surface search and navigation radars as well as a MK46 Optical Sight System. There are two MK38 25 mm machine guns and eight universal mounts for .50 caliber machine guns and MK40 grenade launchers. The RCSS has the original aft flight deck as well as a forward flight deck to accommodate helicopter and UAV operations.²²²

Barges and Barracks Ships

There exist numerous types of barges and barrack ships in the USN inventory. Their troop capacities range from 100 to 1000 personnel. Vietnam RF's used self propelled barracks ships (APB) and non-self propelled barracks craft (APL) as part of their MOB.²²³ Figure 55 is an example of a former self propelled barracks ship used in Vietnam.

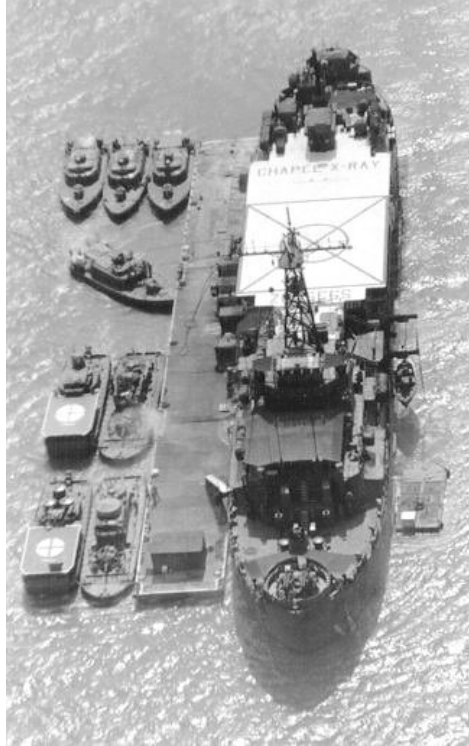

Figure 55. APB-39 Mercer in support of Mobile Riverine Forces.²²⁴

The APB-39 Mercer was reclassified as APL-39. For this particular barracks ship, the length is 328 ft, the beam is 50 ft, and the draft is 11 ft. Small boats can moor alongside on a floating causeway as shown in Figure 55. Also, the APL has multiple universal gun mounts for defense.

Nobriza

The Nobriza is a Colombian Navy Riverine Support Patrol Vessel. Figure 56 is the Nobriza.



Figure 56. The Nobriza²²⁵

The Nobriza has a length of 129 ft, a beam of 31 ft, a draft of less than 4 ft, and a max speed of 9 knots. The Nobriza has been modified with a crane to recover small boats for maintenance purposes. It is armored and has automatically controlled MK-19 40 mm grenade launchers, two double-barrel M2 .50 caliber machine guns, and numerous other crew served weapons. It also has a flight deck to launch and recover UAV's and helicopters.²²⁶ Although the Nobriza lacks the personnel capacity to accommodate an entire RF, several Nobriza's or a single Nobriza with another platform may provide an excellent alternative for a MOB in the riparian environment.

Endurance Class LST

The Republic of Singapore Ship (RSS) 207 Endurance Class LST replaced the ex-County class LST's of the Republic of Singapore Navy. One of the principal missions of this platform is to serve "as a multi-purpose Logistics Support and Command ship in support for naval operations."²²⁷ Figure 57 is the RSS-207 Endurance.



Figure 57. RSS-207 Endurance²²⁸

The Endurance has a length of 522 ft, a beam of 69 ft, a 16.4 ft draft, and a max speed greater than 15 knots. The Endurance has large well-deck capable of accommodating numerous landing craft and small boats. There are two 25 ton deck cranes to recover small boats. The Endurance has advanced surveillance radars and multiple anti-surface and anti-air weapon and sensor systems. This weapon system includes a gun fire control system, electro-optic director, 76 mm Oto Molera gun, two 0.5 inch machine guns, and two missile systems. The Endurance has a flight deck and hangar to accommodate two helicopters. Unlike older LST's, it has highly automated and integrated systems, which enable reduced manning for the ship.²²⁹

Teluk Bone LST

The Kapal Republik Indonesia (KRI), or Republic of Indonesia Ship, 511 Teluk Bone is the former USN LST-839 Iredell County. Decommissioned from the USN in 1970, the LST-839 was loaned to Indonesia and renamed Teluk Bone to serve as one of Indonesia's large landing ship.²³⁰ Figure 58 is the Teluk Bone.



Figure 58. LST-839 Iredell County²³¹

The Teluk Bone has a length of 328 ft, a beam of 50 ft, a 14 ft draft, and a max speed of 12 knots. The Teluk Bone has a large well deck to carry vehicles. Besides the well deck, it uses floating causeways to moor small boats alongside. Also, the Teluk Bone has multiple gun mounts and a flight deck

Sri Inderapura LST

The Kapal Di-Raja (KD), or Royal Ship, 1505 Sri Inderapura is the former USN LST-1192 Spartanburg County. Decommissioned from the USN in 1994, the LST-1992 was sold to Malaysia and renamed Sri Inderapura in 1995. The LST was one of the Newport LST class, which replaced the traditional bow door design LST. One major change is that amphibious vehicles can be launched from the ship's stern deck.²³² Figure 59 is the Sri Inderapura.



Figure 59. LST-1192 Spartanburg County²³³

The Sri Inderapura has a length of 522 ft, a beam of 69 ft, a 20.2 ft draft, and a max speed greater than 15 knots. The Sri Inderapura also has multiple gun mounts and a flight deck. The Sri Inderapura along with other MOB alternatives was further analyzed in order to determine whether or not they would be feasible as a MOB.

4.5.2.2 Feasibility Analysis

In order for a MOB alternative be feasible it must have adequate troop capacity, storage capacity, must be able to maneuver in the river, and must be able to perform maintenance and support on the SURC's with the added constraint that alternatives must be capable of being employed by 2012. Using these factors, the RST evaluated the different alternatives to determine their feasibility.

Troop capacity is an important factor. For the RST scenario, the RF and bolt on detachments consisted of approximately 250 to 300 personnel while operating from the MOB. As a result, the MOB must have sufficient berthing for the RF. At the very least, berthing for 150 personnel will suffice, but this results in most troops alternating the use of the racks, which is known as hot-racking.

The MOB must have enough storage capacity to sustain the crew and RF for at least 15 days. Storage capacity includes storage for food, ammunition, water, and

fuel. A 15 day supply of food will be approximately 100 pallets that are 46 cubic feet and 0.5 ton each. On average, each day the RF will require 2.5 lbs of ammunition per person and for 15 days, this will be about four tons of ammunition. The space needed for ammunition is almost 400 cubic feet. This figure does not include ammunition for the MOB's weapons. Personnel will need about six gallons of drinking and cooking water that cannot come from the river. Nearly 20 gallons per person must be purified from the river for the heads. This results in storage of approximately 50,000 gallons of drinking and feeding water plus nearly 6,000 gallons of purified water that is required each day. The SURC's will consume approximately 40,000 gallons of fuel in 15 days. The MOB will need fuel storage for the SURC as well as itself. Adequate storage tanks for water and fuel are ideal, but if the tanks are not big enough then separate storage containers such as SIXCON's must fit on the ship. Each SIXCON can carry 900 gallons of liquid. Its total volume is 208 cubic feet, and the overall weight will be close to five tons. The actual number for storage capacity depends on the total number of personnel in the MOB.

Operating mostly in confined river-ways, the MOB must be able to maneuver in small areas with shallow depths. For the RST's scenario, the AO has a minimum depth of eight meters and width of one mile. Maintaining and supporting the small boats is necessary. The MOB must be able to either store the SURC's inside the platform or have them moor alongside. Well decks can accommodate small boats, while floating causeways can moor boats alongside. The MOB must also have some area to perform maintenance on the boats.

The alternatives for the MOB could be a single platform or a combination of platforms. To summarize, the MOB, at a minimum, should have 150 extra racks for the RF. As far as storage, the MOB needs at least 5000 cubic feet of storage for food, 400 cubic feet of storage for ammunition, 50,000 gallon drinking and feeding water tanks, 6,000 gallons of purified water made each day, and 40,000 gallon fuel tanks just for the SURC's. If storage tanks for water and fuel are not big enough, then adequate storage for SIXCON's is necessary. The MOB must also have a draft less than 26 feet, and it should be able to store the SURC's and perform maintenance on the boats. Finally,

the MOB must be available by 2012. The feasibility matrix for the MOB can be seen in Table 4.

Alternative	Troop Capacity	Storage Capacity	Maneuverability	Maintenance & Support
LCS	NG	G	G	G
HSV	NG	G	G	G
LSV	NG	NG	G	G
RCSS	G	G	G	G
Barge	G	G	NG	G
Nobriza	NG	NG	G	NG
RSS-207 Endurance	G	G	G	G
KRI-511 Teluk Bone	NG	G	G	G
KD-1505 Sri Inderapura	G	G	G	G
Nobriza + Barge	G	G	G	G
Multiple Nobrizas	G	NG	G	NG

G: Go NG: No Go

Table 4. MOB Feasibility Matrix

Troop capacity was the driving factor for the MOB. Many of the alternatives were infeasible because they did not have enough berthing for the estimated RF. The LCS may be an excellent ship by itself, but when supporting an RF, it does not have enough space to berth all of the personnel. The total number of racks in the Lockheed Martin LCS is 75²³⁴ and the General Dynamics LCS is 110.²³⁵ The KRI-511 Teluk Bone, being a former USN LST, may have some of the capabilities we need to support the RF except for the troop capacity. The troop capacity is only 145.²³⁶

The LSV and the HSV are capable of having 150 racks, but they were deemed infeasible because extra berthing is either temporary or limits other capabilities.²³⁷ Using the troop carrier variant of the LSV limits what other capabilities the LSV has such as storing platforms and other supplies as well as launching and recovering helicopters and UAV's. The deck space that would normally be used for storage will be used for racks instead. The HSV normally has room for only 65 extra troops. It can temporarily be reconfigured to have 87 extra racks, but for the scenario, this type of living condition for six months is not ideal.²³⁸ A barge is another platform that was considered infeasible. Although a tug can move the barge to a specific location

on the river, the barge by itself is not maneuverable to meet with SURC's if necessary. Finally, the Nobriza may perform well in the riverine environment by itself, but it cannot support the entire RF. The troop capacity of the Nobriza is 43, the storage capacity is too small to handle supplies for the RF, and it is unable to support all of the SURC's by itself.²³⁹ Multiple Nobriza's can accommodate the troops and the SURC's. However, there still is not enough storage for fuel and water for the RF; each Nobriza can only make water and store fuel for its own crew.

The four feasible alternatives for the MOB are the RCSS, RSS-207 Endurance, KD-1505 Sri Inderapura, Nobriza + Barge. Table 5 provides more information on the MOB's.

Alternative	Self Defense	Crew	Troop Capacity	Storage Capacity	Maneuverability	Maintenance
RCSS	Surface Search Radar, MK46 Optical Sight System, (2) Mk- 38 25 mm Chain Guns, Mk-15 CIWS, (8) Universal Gun Mounts, Forward and Aft flight decks	248	352	253,570 gal for fuel, 42,808 gal for water, Well deck, Food storage for crew and troops for 30 days	Length 522.25 ft, Beam 69.75 ft, Draft 19.8 ft, Speed 20+ knots	Well Deck and Causeway, IMA with maintenance support facility shops based on LSD to include Hull Technician, Machinist, Engine, Electrical, Composite Repair, Gunsmith, and Electronic Shops
RSS-207 Endurance	Surveillance Radar, Anti-Surface/Air Sensor System, 76mm Oto Melara, (2) Mistral SAM, (2) .5 in machine gun, Gun Fire Control System, Aft flight deck for two helicopters.	65	350	Well Deck, Hangar, and Tank Deck for storage	Length 462.6 ft, Beam 68.9 ft, Draft 16.4 ft, Speed 15+ knots	Well Deck and Causeway, (2) 25 ton deck cranes
KD-1505 Sri Inderapura	Surface Search Radar, Mk-15 CIWS, (2) twin 3"/.50 cal, (2) .25mm chain guns, (6) .50 cal, Aft flight deck	248	307	150,000 gal for fuel, 42,808 gal for water, Well deck, Food storage for crew and troops for 30 days	Length 561.75 ft, Beam 69.75 ft, Draft 20.2 ft, Speed 20+ knots	Well Deck and Causeway, Ship's Force to include Hull Technicians, Machinery Repairmen, Electricians, and other maintenance related ratings part of the ship's crew
Nobriza + Barge	Nobriza: Mk-19 40 mm grenade launcher, (2) double-barrel M2 .50 caliber machine guns, multiple small arms, Aft flight deck Barge varies	31 in Nobriza + 30 in barge	39 in Nobriza + adequate berthing in barge	38,600 gal for fuel, 25,890 gal for water, Adequate storage in barge	Nobriza: Length 128.8 ft, Beam 31.2 ft, Draft 3.1 ft, Speed 9 knots Barge size varies approximately 300 ft by 50 ft	Causeway, Maintenance support on barge

Table 5. Feasible MOB Information.^{240 241 242 243 244 245}

The RCSS, Endurance, Sri Inderapura, and Nobriza + Barge are capable of supporting the RF as a MOB. They have adequate sensors, surveillance, and weapon systems for defensive and offensive measures. They have enough racks for the troops as well as storage capacity for the necessities, such as food, water, fuel, and ammunition. Their sizes are small enough for the AO. They are also fully capable of supporting and maintaining the SURC's, whether the boats are inside in a well deck or outside moored to a floating causeway. These alternatives were further analyzed to determine any potential risks in each platform.

4.5.2.3 Risk Analysis

There are many risks associated with the different alternatives for the MOB. Some of these risks include technology availability and change in the AO. The alternatives for the MOB belong to another country, do not exist yet, or are being used for other operations. So, there exists a possibility that the MOB will not be available. Also, the alternatives may be feasible in the RST's scenario, but hazards exist when the size of the AO decreases. For the risk analysis, the RST assumed that the number of troops will remain at approximately 224 personnel.

Certain risks exist with the RCSS. A major risk is that the RCSS is not available because funding, which is approximately \$160 million, was not allocated for the proposed LST-1179 Class conversion. Or, if the LST does get converted, the RCSS is used for a different mission other than the MIO for the RST's scenario. Possible ways to mitigate the risk is to convert multiple LST's to the RCSS or use another amphibious ship if the AO permits. However, if the AO becomes significantly smaller, a MOB as large as the RCSS will be infeasible. The RF may have to use a smaller MOB, a FOB, or a GFS.

Another way to mitigate the risk that the RCSS may not be available is to use a former USN LST-1179 Class ship that is currently used in other navies. For example, Malaysia's KD-1505 Sri Inderapura may be capable of replacing the RCSS even though it will not have the changes that the MIT report proposed. Other countries, such as Mexico, Brazil, Chile, Australia, Spain, and Morocco, have former USN LST-1179 Class ships.²⁴⁶ Depending on the location of the AO, these countries can play a role

in coalition operations. However, there still exists the possibility that these ships will not be available for the RF due to the use by the other countries for other operations. Again, this results in the RF having to use a smaller MOB, a FOB, or a GFS.

The RF is not limited to just LST-1179 Class ships from other countries. Singapore's RSS 207 Endurance Class ship has similar capabilities of the RCSS and is a feasible alternative for a MOB. However, the same risk that it may not be available exists. There are only four ships in the class, and they may already be in use by the Republic of Singapore Navy.

Like the other platforms, the Nobriza/Barge combination has the risk that they are not available for use for the same reasons. As a result, the RF will have to use a different basing option if the number of troops remains at 224.

The level of effectiveness and performance of each alternative can help determine more ways to mitigate the risk. For example, if one MOB performed extremely well, then having more ships in the inventory to prevent the risk of non-availability may be an easier decision to make.

4.5.3 Global Fleet Station

The RF will require a support base to conduct command oversight, planning, staging, logistics and maintenance. The support base may be afloat or shore. Its choice will be dependent on the mission and options available. The support base and associated systems must provide connection to theater logistics systems to ensure continuity of supply and support.²⁴⁷

A sea base is the likely choice if the area of operations supports. A variety of vessels can be used, including amphibious vessels such as the Dock Landing Ship, High Speed Vessels, logistics vessels, commercial vessels, or barges. Naval ships are optimal if available as they provide communications assets, hotel services, and logistics support. Amphibious ships have excess capacity for food, fuel, and ammunition. Sea Bases can re-supply quickly using standard Navy methods. They can be relocated to reduce vulnerability and have inherent defenses. They can also be relocated, as operations develop to extend the range of the riverine forces.²⁴⁸

The GFS is the current Navy sea base initiative. “The purpose of a GFS is to establish a persistent sea base of operations from which to aggregate, disaggregate and re-aggregate force packages tailored for a variety of missions within a regional area of interest, focusing primarily on Phase 0/Shaping and Stability operations, TSC, maritime domain awareness, and tasks associated specifically with the war on terror.”²⁴⁹

GFS is a direct application of the Naval Operations Concept, 2006, representing an adaptive force package that supports the 1000-Ship Navy concept within a regional area of interest. Each GFS is self-sustaining sea base from which to provide a persistent presence to conduct regional Phase 0 operations ranging from TSC activities to maritime interdiction and counter-piracy. It is a sea-station from which tailored and adaptive force packages are launched in response to humanitarian crises, natural disasters, and counter-terrorism tippers. It is a center for intelligence and information fusion in support of enhanced global maritime awareness, and when networked with other fleet stations, each GFS fusion center will serve as an intelligence feeder for global maritime intelligence integration. Most importantly, these information fusion centers offer increased regional maritime domain awareness to host nation partners provide timely queuing to interdict illegal transnational activities.²⁵⁰

At a minimum, each GFS include a modularly configurable ship (e.g. LPD, LSD, HSV, LCS) capable of serving as the primary station/command ship to transport a variety of riverine craft and helicopters/UAV's, mobile training teams, Seabees, materiel, medical teams, other innovative Navy and Marine Corps adaptive force packages, and a limited security force. This ship provides sufficient C4I, limited medical facilities, configurable classroom space, and containerized Intermediate/Depot Level maintenance shops (Expeditionary Maintenance Facilities) to sustain Phase 0 operations throughout the region. A helicopter detachment (and eventually a UAV detachment) provides air support for each GFS. As a persistent sea base, each GFS serves as a self contained head quarters for regional operations, and has the capacity to repair and service all ships, small craft, and aircraft assigned.²⁵¹

Figure 60 the Wasp Class (LHD-1), an alternative for the GFS.



Figure 60. GFS Alternative the Wasp Class (LHD-1)²⁵²

The GFS command ship must maintain robust and secure joint C4I capabilities. There should be a medical treatment facility onboard the GFS command ship able to provide medical support/humanitarian assistance as well as sufficient combat construction equipment and material to support Phase 0 operations in remote locations. The information fusion cell is equipped with sufficiently robust and secure communications to handle the fusion of open source information as well as tactical and operational intelligence. The GFS needs to have sufficient language expertise onboard to provide direct interaction with indigenous populations throughout the region.²⁵³

One of the major constraints for the RST's concept of GFS is that is operational by 2012. Given the current 10 – 20 year timeframe to develop and build a ship, the RST used existing fleet of U.S. Navy Ships for GFS alternatives. In Table 6, logistical capacities (vehicle, cargo, and personnel) are compared for several U.S. Amphibious Ship alternatives.

Characteristics	LHD	LHA	LPD-4	LPD-17	LSD-41	LSD-49
Vehicle square, feet	24,012	28,700	14,000	25,000	11,831	20,200
Cargo, cubic feet	145,000	156,000	51,000	35,000	8,970	67,600
Draft, feet	26.5	26.0	23.0	23.0	20.0	20
Officer accommodations, mission package	173	172	68	66	27	27
Enlisted accommodations, mission package	1720	1731	641	638	375	380

Table 6. U.S. Amphibious Ship Capacities²⁵⁴

“The GFS concept is based on the establishment of a network of sea based fleet stations worldwide, each one servicing a specific region and are of responsibility. Suggested locations for these initial sea based GFS’s include Southeast Asia, Eastern Africa, Arabian Gulf, South Asia, South and Central America.”²⁵⁵ The RST’s GFS was located in a permissive environment 10 to 20 miles from the Kampar River mouth in Sumatra, Indonesia.

4.5.4 Supply System

The amount of supply to keep the Riverine Force (RF) operating was based upon the demand for class I (subsistence), III (petroleum, oil, and lubricants), V (ammunition), and IX (repair parts) supplies. Each supply class demand rate was dependent upon the number of personnel on the support base and operational tempo of the force. For ease of labeling all tables and figures the RST designated the mobile operating base alternative as: a barge and Nobriza as Mobile Operating Base 1 (MOB1), and a RCSS type vessel as Mobile Operating Base 2 (MOB2). The most likely number of personnel at each of the basing alternatives is documented in Table 7. The maximum and minimum number of personnel expected at each basing alternative is in Table 8.

Personnel	FOB	MOB1	MOB2
Linguists	6	6	6
Civil Affairs	6	6	6
MESF	72	0	0
UAV	20	20	20
EOD	6	6	6
MTT	6	6	6
Inodnesian Forces	30	30	30
RF	224	224	224
Ship Crew	0	62	222
Connector Crew	10	10	10
Likely Personnel	380	370	530

Table 7. Most Likely Number of Personnel at Each Basing Alternative.

Number of Personnel at Basing Alternative			
	Minimum	Most Likely	Maximum
FOB	350	380	430
MOB1	340	370	520
MOB2	500	530	580

Table 8. Minimum, Most Likely, and Maximum Number of Personnel at Each Basing Alternative.

4.5.4.1 Feed Plan

Each basing alternative was a unique force assigned for mission accomplishment. All basing alternatives had a storage capacity for 15 days for food.²⁵⁶ The feed plan consisted of a triangular distribution with a minimum, maximum, and most likely number of people. Each person on the basing alternative eats at 0600, 1200, 1800 and a quarter eat at 2400.

On 21 June 1995, the Surgeon General released a revised policy on the use of the MRE (Meals Ready to Eat) as the sole source of subsistence. This revised policy allows MRE's to be consumed as the sole source of subsistence for up to 21 days.²⁵⁷

“Even though studies have concluded that individuals can subsist solely on MRE’s for up to 21 days, morale generally begins to suffer after two or three days.”²⁵⁸ Based on the fact that the RF cannot subsist solely on MRE’s for the entire operation, the RST determined that the meals served at the FOB were Utilized Group Rations Heat and Serve (UGR H&S) for breakfast and supper supplying two hot meals a day for all personnel. For lunch MRE’s (Meals Ready to Eat) were served. The UGR H&S meals were delivered by pallet with eight Unitized/Individuals (U/I’s) each containing 50 meals for a total of 400 servings per pallet.²⁵⁹ MRE’s were delivered by pallet with 48 U/I’s each containing 12 meals for a total of 576 servings per pallet.²⁶⁰

Each meal during the day was complimented with pouch bread and UHT milk. Pouch bread was delivered by pallet with 15 U/I’s each containing 96 servings for a total of 1440 servings per pallet.²⁶¹ UHT milk was delivered by pallet with 120 U/I’s each containing 27 servings for a total of 3240 servings per pallet.²⁶² Every breakfast was complimented with breakfast cereal delivered by pallet with 50 U/I’s each containing 72 servings for a total of 3600 servings per pallet.²⁶³ Table 9 summarizes the number of pallets needed for the FOB alternative.

Total amount of food for 15 days at the FOB								
	Max Personnel	Storage Capacity	UGR Servings/ person/day	MRE Servings/ day	Pouch Bread Servings/ person/day	UHT Milk Servings/ person/day	Cereal Servings/ person/day	Total Pallet Storage
FOB	430	15	2	765	3.25	2	1	
	Total Servings:		12900	11475	20963	12900	6450	
	Total Pallets:		32	20	15	4	2	73

Table 9. 15 Day Food Supply for FOB

The MOB planning factor for food was based on historical shipboard consumption of 5.62 lbs per person per day. Non-refrigerated food was 3.20 lbs per man per day and refrigerated food accounts for 2.42 lbs per man per day.²⁶⁴ MRE’s were included to account for the meals eaten by the RF personnel performing the MIO. Table 10 summarizes the number of pallets needed for MOB1 and MOB2 alternatives.

Total amount of food for 15 days at MOB1 and MOB2						
	Max Personnel	Storage Capacity	Lbs. Non-Refrigerated/ person/day	MRE Servings/ day	Lbs. Refrigerated/ person/day	Total Pallet Storage
MOB1	520	15	3.2	240	2.4	
	Total Lbs:		24960	3600	18720	
	Total Pallets:		25	6	19	50
MOB2	580	15	3.2	240	2.4	
	Total Lbs:		27840	3600	20880	
	Total Pallets:		28	6	21	55

Table 10. Total Amount of Food for 15 Days at MOB1 and MOB2

Based on Table 10 each basing alternative had a different storage capacity. The minimum storage capacity needed for 15 days was calculated in Table 11. Each of the pallet size, volume, and weights for the FOB was taken from the Defense Logistics Agency Ration website.²⁶⁵ Pallet sizes sent to the MOB's were based upon the standard Navy pallet of 13.33 square feet, average volume of 47.8 cubic feet, and an average weight of 1000 pounds.

Storage for 15 days of food at the FOB							
		UGR	MRE	Bread	Milk	Cereal	Total
FOB	Pallets	32	20	15	4	2	73
	Size (ft ²)	426.6	320	200	53.3	26.7	1026.5
	Volume (ft ³)	1529.6	1122	766.5	171.2	100.0	3689.3
	Weight (lbs)	34176	21960	4950	7880	920	69886
Storage for 15 days of food at MOB1 and MOB2							
		Non-Refrig	MRE	Refrig.	Total		
MOB1	Pallets	25	6	19	50		
	Size (ft ²)	332.7	96	249.5	678.3		
	Volume (ft ³)	1193.1	336.6	894.8	2424.5		
	Weight (lbs)	24960	6588	18720	50268		
MOB2	Pallets	28	6	21	55		
	Size (ft ²)	371.1	96	279.9	747		
	Volume (ft ³)	1330.8	336.6	1003.8	2671.2		
	Weight (lbs)	27840	6000	21000	54840		

Table 11. Storage at Each of the Basing Alternatives.

4.5.4.2 Fuel Plan

The fuel plan was determined from the results in Appendix G and the addition of fuel to operate each of the basing options. Each of the basing options had a minimum of 15 days of storage. The total storage requirements are shown in Table 12.

Total amount of fuel for 15 days at each basing alternative.										
	Storage	MIO gals. /day	Base Ops gals. /day	CONN. gals. /day	Patrol gals. /day	Total gals. /day	Total Gal. Storage	Total Weight (lbs)	Total Volume (cu.ft.)	Total Tons
FOB	15	1993.77	2288	0	385	4666.77	70001.55	469710.4	9358.5	234.86
MOB1	15	2153.88	2152	550	760	5615.88	84238.2	565238.32	11262	282.62
MOB2	15	2153.88	7200	550	760	10663.88	159958.2	1073319.5	21385	536.66

Table 12. Fuel Storage for the Basing Alternatives.

The FOB base fuel usage is a combination of three 60 KW generators at 106 gallons per hour plus 2000 gallons per day for tent heaters, messing, and other services around the base. MOB1 daily consumption of fuel is based upon the Nobriza using 48 gallons per hour²⁶⁶ to operate and the barge using 1000 gallons per day. MOB2 (converted LST 1179 class ship) has a much higher consumption. MOB2's daily consumption is based on operating two generators and two main engines 24 hours a day. The generators consumed 2400 gallons per day while the main engines consume 4800 gallons per day.²⁶⁷

The FOB use of the logistic connector would be only to move supplies from the supply vessel to the FOB. Therefore the need for fuel would be zero due the fact that the logistic connector would refuel its organic fuel tanks when taking on stores at the supply ship. The MOB's had a much higher use for the logistic connectors if liquid waste was not contracted to an outside service provider. If the MOB's logistical connector was used to transport liquid waste, then every day the blackwater and graywater was unloaded and transported out the sea. This involves a 10 hour trip to dump the waste water.

All three of the basing options had a need for patrol craft to perform a picket mission in the vicinity of the support base. For all the basing options there was

one SURC operating 24 hours a day to patrol the river area near the FOB and ward off any potential attackers. All of the basing options also had the requirement to provide one patrol craft to protect the logistic connectors when they made a supply run.

4.5.4.3 Water Plan

Due to advances in water purification, the RST determined that the majority of the water demand was provided through river water purification. According to the Marine Corps Reference Publication 4-11A Vol. 1 CSS Field Reference Guide personnel the FOB will consume 8.9 gallons of water per person per day to sustain the force. Table 13 summarizes the data.

<i>Tropical Zone</i>	<i>Daily GPM Requirements</i>	
Function	Sustaining	Minimum
Drinking	3	3
Hygiene	1.7	1
Field Feeding	2.8	0.8
Heat Casualty	0.2	0.2
Medical	0.4	0.4
Subtotal	8.1	5.4
+10%	0.8	0.5
Total	8.9	5.9

Table 13. Daily Gallons of Water per Person Required in a Tropical Zone.²⁶⁸

MOB1 and MOB2, since being waterborne use a much higher level of consumption to operate the ship. The rule of thumb for shipboard use is 30 gallons per person per day for all services²⁶⁹. The RST determined that of the 30 gallon usage per day only 8.9 gallons will be needed to be delivered for feeding and drinking. The other 21 gallons will be produced by shipboard water purification systems in order to supply the rest of the water needs onboard. Table 14 was the total water storage for each basing alternative.

Total amount of drinking/hygiene water for 15 days at each basing alternative.								
	Number of Personnel	Storage Capacity	Water gals/day	Total gals/day	Total Storage (gals)	Total Weight (lbs)	Total Volume (cu.ft.)	Total Tons
FOB	430	15	9	3870	58050	481815	7760.7	240.91
MOB1	520	15	9	4680	70200	582660	9385.03	291.33
MOB2	580	15	9	5220	78300	649890	10467.9	324.95

Table 14. Water Storage for Each Basing Alternative.

4.5.4.4 Ammunition Plan

The amount of ammunition needed at each of the basing alternatives was based upon a Marine Corps infantry battalion consumption. A Marine Corps infantry battalion consumes about 2.5 lbs of ammunition per person per day.²⁷⁰ Since the RF was not utilized for full combat operations the total consumption per person was less. To compensate for the differences the RST determined the number of personnel most likely to be involved in a fire fight. Table 15 summarizes the number of personnel most likely to expend ammunition.

Armed Personnel	FOB	MOB1	MOB2
Linguists	0	0	0
Civil Affairs	0	0	0
MESF	72	0	0
UAV	0	0	0
EOD	6	6	0
MTT	0	0	0
Inodnesian Forces	0	0	0
RF	170	170	170
Ship Crew	0	31	110
Connector Crew	10	10	10
Likely Personnel	258	217	290

Table 15. Number of Armed Personnel at Each Basing Option Likely to Expend Ammunition.

Based on the number of personnel who expend ammunition the RST was able to determine the amount of ammunition needed for a minimum of 15 days. Table 16

summarizes the storage needed for a minimum 15 days of ammunition. However, palletized ammunition comes in much greater quantities than what the RF will be expending. Therefore the amount of ammunition to be transferred up the river to the basing alternative will be no more than one or two pallets a week.

All Basing Alternatives								
Weapon	Number of Weapons	Ammo/DODIC	Sustain Rate /day /weapon	Rounds /day	Rounds /Pallet	Weight /Pallet	Total Pallets	Days of Sustainment
M16A3	224	CTG, 5.56mm Ball (A059)	3.88	869.12	80640	3356	1	93
M203	39	CTG, 40mm HEDP (B546)	1.14	44.46	2650	1372	1	60
12 GA 500A2	36	CTG, 12 GAGE (A011)	1.27	45.72	9000	3268	1	197
M9	224	CTG, 9mm Ball (A363)	0.79	176.96	92160	2860	1	521
M240B	33	CTG, 7.62mm Ball (A131)	7.65	252.45	38400	3769	1	152
MK43	29	CTG, 7.62mm Ball (A131)	7.65	221.85	38400	3769	1	173
M2	32	CTG, CAL .50 (576)	78.60	2515.20	9600	3700	1	4
MK19	19	CTG, 40mm HEDP (B542)	16.80	319.20	3816	1518	1	12
MK21	2	CTG, 7.62mm Ball (AA11)	21.40	42.80	38400	3652	1	897
MK67	--	Grenade Frag (G881)	1.00	1.00	1530	1324	1	1530
FOB Security Detachment								
M9	72	CTG, 9mm Ball (A363)	0.79	56.88	92160	2860	1	1620
M16A3	27	CTG, 5.56mm Ball (A059)	3.88	104.76	80640	3356	1	770
M203	36	CTG, 40mm HEDP (B546)	1.14	41.04	2650	1372	1	65
12 GA 500A2	13	CTG, 12 GAGE (A011)	1.27	16.51	9000	3268	1	545
MK21	2	CTG, 7.62mm Ball (AA11)	21.40	42.80	38400	3652	1	897
M2	9	CTG, CAL .50 (576)	78.60	707.40	9600	3700	1	14
M240B	10	CTG, 7.62mm Ball (A131)	7.65	76.50	38400	3769	1	502
MK19	5	CTG, 40mm HEDP (B542)	16.80	84.00	3816	1518	1	45
M252	3	CTG, 80mm HE (B868)	0.46	1.38	159	2008	1	115
MOB1 Security								
M9	50	CTG, 9mm Ball (A363)	0.79	39.50	92160	2860	1	2333
M16A3	25	CTG, 5.56mm Ball (A059)	3.88	97.00	80640	3356	1	831
M203	5	CTG, 40mm HEDP (B546)	1.14	5.70	2650	1372	1	465
12 GA 500A2	5	CTG, 12 GAGE (A011)	1.27	6.35	9000	3268	1	1417
MK21	0	CTG, 7.62mm Ball (AA11)	21.40	0.00	38400	3652	1	0
M2	4	CTG, CAL .50 (576)	78.60	314.40	9600	3700	1	31
M240B	5	CTG, 7.62mm Ball (A131)	7.65	38.25	38400	3769	1	1004
MK19	5	CTG, 40mm HEDP (B542)	16.80	84.00	3816	1518	1	45
M252	3	CTG, 80mm HE (B868)	0.46	1.38	159	2008	1	115
MOB2 Security								
M9	50	CTG, 9mm Ball (A363)	0.79	39.50	92160	2860	1	2333
M16A3	25	CTG, 5.56mm Ball (A059)	3.88	97.00	80640	3356	1	831
M203	5	CTG, 40mm HEDP (B546)	1.14	5.70	2650	1372	1	465
12 GA 500A2	5	CTG, 12 GAGE (A011)	1.27	6.35	9000	3268	1	1417
MK21	0	CTG, 7.62mm Ball (AA11)	21.40	0.00	38400	3652	1	0
M2	4	CTG, CAL .50 (576)	78.60	314.40	9600	3700	1	31
M240B	5	CTG, 7.62mm Ball (A131)	7.65	38.25	38400	3769	1	1004
MK19	5	CTG, 40mm HEDP (B542)	16.80	84.00	3816	1518	1	45
MK75	1	CTG, 76mm	1.38	1.38	30	2096	1	22

Table 16. Number of Weapons, Expenditure Rates, and Storage for Each Basing Alternative.

4.5.4.5 Repair Plan

All the basing alternatives have 12 SURC's attached to perform the MIO. Based on information given to the RST from NECC the repair parts consumption rate for a SURC is 46.67 lbs per day. Table 17 summarizes the amount of repair parts needed.

Total amount of repair parts for 15 days at each basing alternative.							
Number of SURC's	Storage Capacity	Repair lbs/SURC/day	Total lbs./day	Total Storage	Total Pallets	Total ft ²	Total Tons
12	15	46.7	560	8400	9	120	4
13	15	46.7	607	9100	10	133	5
14	15	46.7	653	9800	10	133	5
15	15	46.7	700	10500	11	147	5
16	15	46.7	747	11200	12	160	6

Table 17. Summary of Repair Parts Needed at All Basing Alternatives.

4.5.4.6 Waste Plan

Each of the basing alternatives generates waste whether human or from consumables. All of this waste needs to be disposed of properly. The FOB, being land based, disposed of human waste at the four hole head burn-out facilities on base. The mobile operating base alternatives, however, was not able to dispose of blackwater, graywater, or bilge water overboard. Therefore the MOB alternatives were forced to load all of the waste onto the logistic connector or contract services from the host nation in order to dispose of the waste.

The amount of waste generated at the FOB was based on the 5.6 lbs per person per day from consumables. The calculation for blackwater and graywater production at the MOB alternatives is based upon an amount equal to 125% of the total water consumption. Since each person on board a ship consumes about 30 gallons per day the amount of liquid waste to be brought back to the supply ship is summarized in Table 18. However, these amounts may be decreased by onboard waste processing centers.

Total amount of waste water for 15 days at each basing alternative.									
	Number of Personnel	Storage Capacity	Water gals./day	Waste Factor	Total gals./day	Total gal. Storage	Total Weight (lbs)	Total Volume (cu.ft.)	Total Tons
MOB1	520	15	30	1.25	19500	292500	2427750	39104	1214
MOB2	580	15	30	1.25	21750	326250	2707875	43616	1354
Total amount of solid waste for 15 days at each basing alternative.									
	Number of Personnel	Storage Capacity	Waste lbs/day	Total lbs/day	Total lbs Storage	Total Pallets	Total sq.ft.	Total Tons	
FOB	430	15	5.6	2408	36120	72	963	18	
MOB1	520	15	5.6	2912	43680	87	1165	22	
MOB2	580	15	5.6	3248	48720	97	1299	24	

Table 18. Amount of Waste Storage at Each Basing Alternative.

4.5.4.7 Physical Flow

The movement of materiel up the river was determined by the craft that is carrying it and the physical properties of the materiel. Repair parts, ammunition, and food were all palletized and stacked on the deck of the logistics connector in order to facilitate transfer. Liquids (fuel and water) were either transported by SIXCON containers or inside organic liquid tanks of the craft.

A SIXCON is a 77” wide, 96” long, by 48” high liquid shipping container that can be easily placed on the deck area of a logistic connector. The shipping mode weight of a SIXCON is 2,600 lbs. and the operational weight is 9,500 -10,500 lbs dependent on the density of the 900 gallons of liquid. Each SIXCON had a volume of 203.95 cubic feet and a deck area of 52 square feet. Each SIXCON was outfitted with components for inter-connecting to other SIXCON’s to create a large mobile liquid station. Normal configuration was six stacked and inter-connected to form an ISO/ANSI configured 8’ x 8’ x 20’ module. This configuration was useful since it fits inside the normal storage containers found at a FOB. However, this is not a requirement and many could be interconnected to form a large liquid tank.

Along with the liquid SIXCON’s would be an inter-connected pump. The pump sits in the same size structure as the SIXCON and weighs 2300 lbs. These pumps were part of the deck space loading in order to offload the liquids without actually moving SIXCON’s around. Since any number of SIXCON’s can be connected to a pump

only one would be necessary. However, the major concern was to ensure that pump head to the pump was maintained.

In order to move the materiel up the river the RST had to create a physical flow to understand the operational complexities. Figure 61 and Figure 62 detail the intricacies of the physical flow and the number of options available to the RF to move materiel. Once the physical flow was completed the RST was able to scope the area of study to a much smaller number of options in order to effectively evaluate those options. Entities highlighted in Figure 61 and Figure 62 show which options the RST focused on during the deliver phase and the return phase.

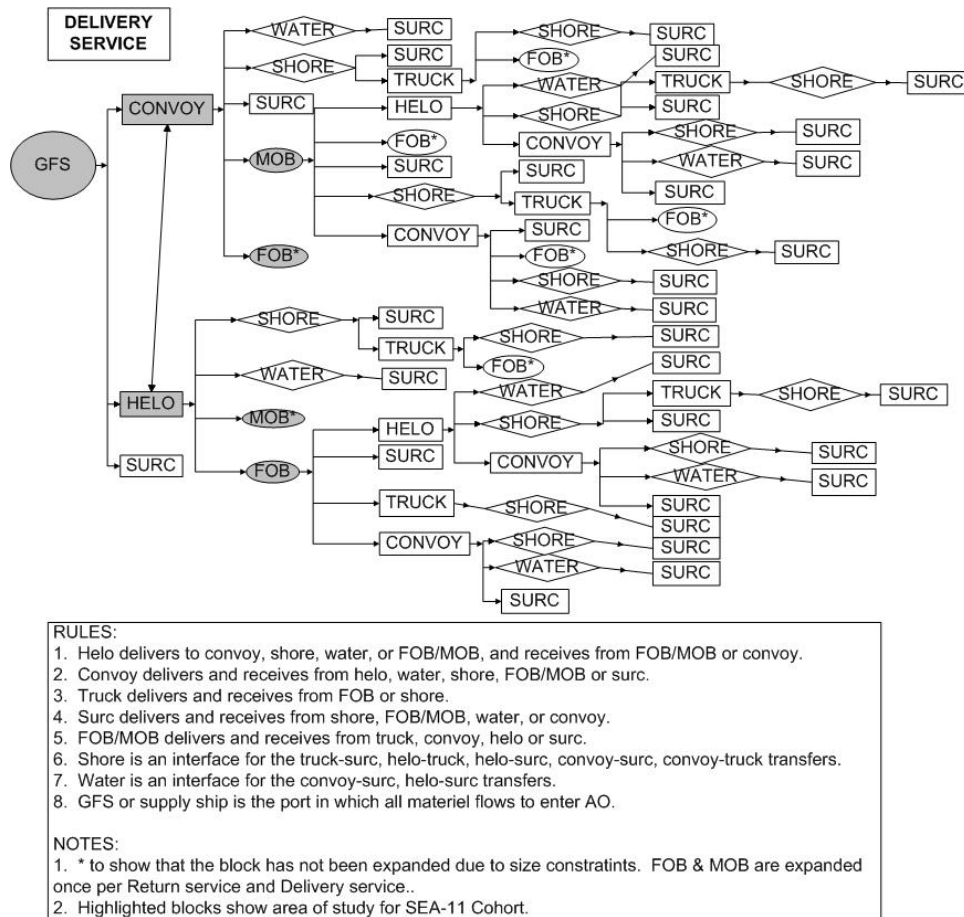

Figure 61. Delivery Service Options of the RF.

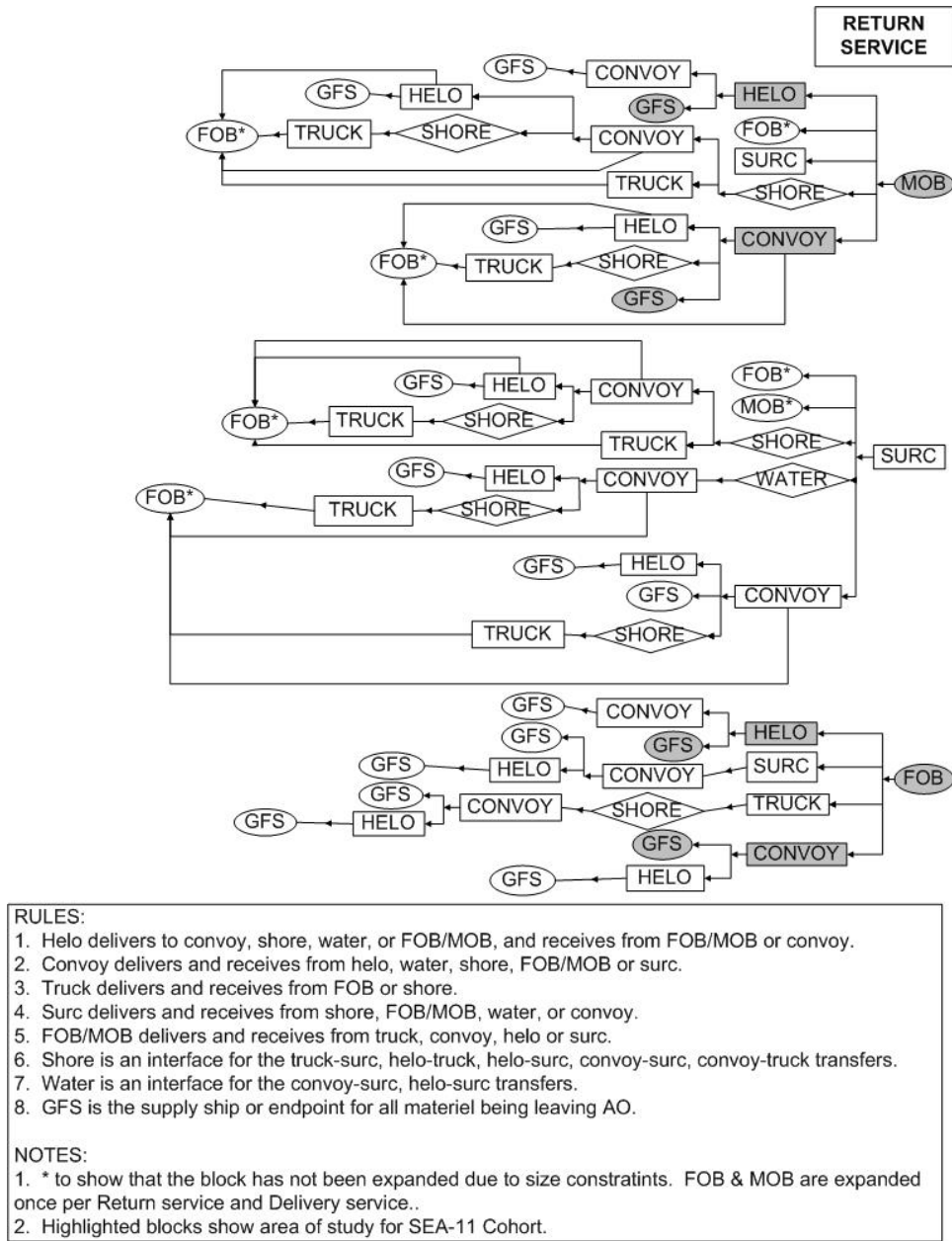

Figure 62. Return Service Options of the RF.

4.6 SUPPLY GROUP

4.6.1 Analysis of Alternatives

The logistics connector alternatives were based on the objectives hierarchy and metrics for supply. Specifically, the RST looked at throughput and loading/unloading time to determine possible for airborne and seaborne logistics connectors. Throughput was measured by cargo capacity in weight and volume versus the speed of the platform

empty and fully loaded. Seaborne logistics connectors loading time was dependent on method of loading and amount of supplies to be loaded. The RST examined three different methods of transfer from the supply ship to the logistics connector: well decks common to big deck amphibious ships, roll-on/roll-off ramps common to pre-positioned ships and crane systems common to most supply ships. Loading time for airborne logistics connectors depended solely on the amount of supplies that were transferred. The following list of logistic connector alternatives to be fielded by 2012 was developed after stakeholder interviews and focused research.

4.6.1.1 Landing Craft Air Cushion (LCAC)

“The LCAC’s mission is to land heavy vehicles, equipment, personnel, and cargo in amphibious assaults.”²⁷¹ It combines the heavy lift capacity of other surface vehicles with the high speeds of helicopters. It is also less affected by weather compared to other ship-to-shore delivery means.²⁷² Figure 63 is the LCAC.



Figure 63. Landing Craft Air Cushion (LCAC)²⁷³

LCAC Parameter Analysis²⁷⁴

- **Maneuverability:** The length of the LCAC is 88 ft. The overall beam is 47 ft. Its draft is 3 ft.
- **Speed:** 40+ knots unloaded. 25+ knots loaded.
- **Capacity:** LCAC cargo area dimension is 1,809 sq. ft. Weight capacity is 60 tons.
- **Food:** Based on an average pallet weight of 1040 lbs, an LCAC can carry 115 pallets of food, yielding 119,600 lbs or 59.8 tons. Based on an average pallet size of 13.75 sq. ft, an LCAC could carry 131 pallets if they did not weigh over 60 tons and were not stacked. This would result in 1801 sq. ft. When carrying food, the LCAC is limited by weight instead of area.
- **Water/Fuel:** Assuming one SIXCON weighs five tons, an LCAC can carry 12 SIXCON's, yielding 60 tons. The area of a SIXCON is 52 sq. ft. When combined to form a SIXCON system, three SIXCON's are stacked side-by-side with another SIXCON on top each of each SIXCON making an 8 ft x 8 ft x 20 ft system. The area of the system is 160 sq. ft. Based on this area, the LCAC could carry 11 SIXCON systems or 66 individual SIXCON's if they did not weigh over 60 tons. This would result in 1760 sq. ft. When carrying water or fuel, the LCAC is limited by weight instead of area.
- **Ammunition/Repair Parts:** Assuming one pallet of ammunition or repair parts weighs 1,000 lbs, an LCAC can carry 120 pallets of ammunition and repair parts, yielding 120,000 lbs or 60 tons. The area of the pallet is 13.33 sq. ft. An LCAC could carry 135 pallets of ammunition and repair parts if they did not weigh over 60 tons and were not stacked. This would result in 1800 sq. ft. When carrying ammunition or repair parts, the LCAC is limited by weight instead of area.

- **Throughput:** Based on a distance of 40 nm, the throughput of the LCAC going from the supply ship to the operating base is $(60 \text{ tons}) \cdot (25 \text{ nm/hr}) / (40 \text{ nm}) = 37.5 \text{ tons/hr}$. This value does not take into account the time to load, unload, and return to the supply ship to begin a new run if necessary. Taking into account the return trip to the supply ship, the throughput is $(60 \text{ tons}) / [(40 \text{ nm} / 25 \text{ nm/hr}) + (40 \text{ nm} / 40 \text{ nm/hr})] = 23 \text{ tons/hr}$.
- **Load/Unload:** The LCAC has a bow ramp to load and unload supplies. Its small size allows it to fit in USN amphibious ships. Not only can the LCAC beach itself, but, unlike other landing crafts, the LCAC has the capability of traveling over land.

4.6.1.2 Landing Craft Utility (LCU) 1610 Class

The LCU's mission is the same as the LCAC, but it is capable of carrying heavier supplies. "Its welded steel hull provides high durability with deck loads of 800 pounds per square foot."²⁷⁵ Figure 64 is the LCU-1610.



Figure 64. Landing Craft Utility (LCU) 1610 Class²⁷⁶

LCU-1610 Parameter Analysis²⁷⁷

- **Maneuverability:** The LCU-1610 has an overall length of 135 ft and a beam of 29.5 ft. Its aft draft is 6 ft 10 in, and its forward draft is 3 ft 6 in to enable beaching.
- **Speed:** 12 knots unloaded. 6 knots loaded.
- **Capacity:** The LCU-1610 cargo deck area is 1,850 square feet and capacity is 143 tons.
- **Food:** Based on weight, the LCU-1610 can carry 275 pallets of food, yielding 143 tons. Based on area, the LCU-1610 can carry 134 pallets that are not stacked. This results in 1842 sq. ft. Because the pallets are capable of being stacked, the capacity for food is limited by weight.
- **Water/Fuel:** Based on weight, the LCU-1610 can carry 28 SIXCON's, yielding 140 tons. Based on area, the LCU-1610 can carry 11 SIXCON systems or 66 SIXCON's, resulting in 1760 sq. ft. The capacity for water and fuel is limited by weight.
- **Ammunition/Repair Parts:** Based on weight, the LCU-1610 can carry 286 pallets of ammunition and repair parts, yielding 143 tons. Based on area, the LCU-1610 can carry 138 pallets that are not stacked. If the pallets are stacked, it can carry 276 pallets. These result in an area of 1839 sq. ft. The capacity for ammunition and repair parts is limited by area.
- **Throughput:** $(143 \text{ tons})(6\text{nm/hr})/(40\text{nm}) = 21.45 \text{ tons/hr}$. Both legs, $(143 \text{ tons})/[(40 \text{ nm}/6 \text{ nm/hr})+(40 \text{ nm}/12 \text{ nm/hr})] = 14.3 \text{ tons/hr}$.
- **Load/Unload:** Figure 64 shows the LCU-1610 loading troops in a roll on/roll off fashion, but its small size allows it to fit in USN amphibious ships.

4.6.1.3 Landing Craft Mechanized (LCM)

The LCM is smaller than the LCU and LCAC, but it is capable of carrying the same weight as the LCAC. “The LCM’s mission is to land personnel, supplies, and equipment in an amphibious assault or in direct support of maritime pre-positioning force operations.”²⁷⁸ Figure 65 is the LCM.



Figure 65. Landing Craft Mechanized (LCM-8)²⁷⁹

LCM Parameter Analysis²⁸⁰

- **Maneuverability:** The LCM has an overall length of 73 ft and a beam of 21 ft. Its aft draft is 4 ft 10 in, and its forward draft is 4 ft 5 in.
- **Speed:** 12 knots unloaded. 6 knots loaded.
- **Capacity:** The cargo deck area is 588 square feet, and the capacity is 60 tons.
- **Food:** Based on weight, the LCM can carry 115 pallets of food, yielding 119,600 lbs or 59.8 tons. Based on area, the LCM can carry 42 pallets of food if they are not stacked or 84 if they are stacked. This results in 577 sq ft. The capacity for food is limited by area.
- **Water/Fuel:** Based on weight, LCM can carry 12 SIXCON’s, yielding 60 tons. Based on area, the LCM can carry three SIXCON

systems or 18 SIXCON's, resulting in 480 sq. ft. The capacity for water and fuel is limited by weight.

- **Ammunition/Repair Parts:** Based on weight, the LCM can carry 120 pallets of ammunition and repair parts, yielding 60 tons. Based on area, the LCM can carry 44 pallets of ammunition and repair parts if they are not stacked or 88 if they are stacked. This results in 586 sq. ft. The capacity is limited by area.
- **Throughput:** $(60 \text{ tons})(6\text{nm/hr})/(40\text{nm}) = 9 \text{ tons/hr}$. Both legs, $(60 \text{ tons})/[(40 \text{ nm}/6 \text{ nm/hr})+(40 \text{ nm}/12 \text{ nm/hr})] = 5.3 \text{ tons/hr}$.
- **Load/Unload:** The LCM has a bow ramp and can beach itself. It also fits in USN amphibious ships.

4.6.1.4 Landing Craft Utility (LCU) 2000 Class

The LCU-2000 Class is a larger landing craft that replaced the older LCU-1466 Class. “These LCUs were built to commercial shipbuilding standards specifically for the U.S. Army.”²⁸¹ Figure 66 is the LCU-2000.



Figure 66. Landing Craft Utility (LCU) 2000 Class²⁸²

LCU-2000 Parameter Analysis²⁸³

- **Maneuverability:** The LCU-2000 has an overall length of 174 ft and a beam of 42 ft. Its aft draft is 9 ft, and its forward draft is 4 ft for beaching.
- **Speed:** 11.5 knots unloaded. 8 knots loaded.
- **Capacity:** The LCU-2000 has a cargo deck area of 2,558 square feet and a capacity of 350 tons.
- **Food:** Based on weight, the LCU-2000 can carry 673 pallets of food, yielding 699,920 lbs or 349.96 tons. Based on area, the LCU-2000 can carry 186 pallets of food if they are not stacked and 372 pallets if they are stacked. That results in 2558 sq. ft. The capacity for food is limited by area.
- **Water/Fuel:** Based on weight, the LCU-2000 can carry 70 SIXCON's, yielding 350 tons. Based on area, the LCU-2000 can carry 15 SIXCON systems or 90 SIXCON's, yielding 2400 sq. ft. The capacity for water and fuel is limited by weight.
- **Ammunition/Repair Parts:** Based on weight, the LCU-2000 can carry 700 pallets of ammunition and repair parts, yielding 350 tons. Based on area, the LCU-2000 can carry 191 pallets of ammunition and repair parts if they are not stacked and 382 if they are stacked. This results in 2546 sq. ft. The capacity for ammunition or repair parts is limited by area.
- **Throughput:** $(350 \text{ tons})(8 \text{ nm/hr})/(40\text{nm}) = 70 \text{ tons/hr}$. Both legs, $(350 \text{ tons})/[(40 \text{ nm}/8 \text{ nm/hr})+(40\text{nm}/11.5 \text{ nm/hr})] = 41 \text{ tons/hr}$.
- **Load/Unload:** It has a larger deck and can carry more weight, but it is too large to be carried by amphibious ships. However, it does have roll on/roll off capabilities.

4.6.1.5 SEACOR Marine 126' MiniSupply Jim G

The Jim G is a mini supply vessel by SEACOR Marine. “Outstanding water and cargo fuel capacities allow these vessels to keep multiple offshore locations up and running.”²⁸⁴ Figure 67 is the Jim G.



Figure 67. MiniSupply Jim G by SEACOR Marine.²⁸⁵

Jim G Parameter Analysis²⁸⁶

- **Maneuverability:** The 126 ft mini supply vessel has a beam of 32 ft. Its loaded draft is 10 ft 7 in.
- **Speed:** 11 knots.
- **Capacity:** The Jim G has separate tanks for oil and water transport. It stores up to 28,931 gallons of fuel, 4,269 gallons of potable water, and 56,287 gallons of drill water (drill water tanks can be used for oil). It also has a cargo deck area of 1,825 square feet and a capacity of 296 tons. The maximum capacity is 320 tons.
- **Food:** Based on weight, the Jim G can carry 569 pallets of food, yielding 591,760 lbs or 295.88 tons. Based on area, the Jim G can carry 132 pallets if they are not stacked and 264 pallets if they are stacked. This results in 1815 sq. ft. The capacity for food is limited by area.

- **Water/Fuel:** The Jim G can carry a total of 89,487 gallons of water and fuel as long as the total weight does not exceed 320 tons.
- **Ammunition/Repair Parts:** Based on weight, the Jim G can carry 592 pallets of ammunition and repair parts, yielding 296 tons. Based on area, the Jim G can carry 136 pallets if they are not stacked and 172 pallets if they are stacked. This results in 1813 sq. ft. The capacity of ammunition or repair parts is limited by area.
- **Throughput:** $(320 \text{ tons})(11 \text{ nm/hr})/(40 \text{ nm}) = 88 \text{ tons/hr}$. Both legs, 44 tons/hr.
- **Load/Unload:** It may be possible to carry the Jim G on USN amphibious ships. If not, the Jim G is transportable by heavy sea lift. However, it does not have its own ramp, and it cannot beach itself. Because it cannot beach itself, it must be able to moor alongside a pier or a floating causeway.

4.6.1.6 150' Crew/Fast Support Vessel Sharon F

The Sharon F is a crew/fast support vessel by SEACOR Marine. Its aluminum hull allows it to reach greater speeds while transporting cargo and liquids. Figure 68 is the Sharon F.



Figure 68. Crew/Fast Support Vessel Sharon F by SEACOR Marine.²⁸⁷

Sharon F Parameter Analysis²⁸⁸

- **Maneuverability:** The 150 ft vessel has a beam of 28 ft. Loaded draft is 10 ft.
- **Speed:** 24 knots unloaded. 22 knots loaded.
- **Capacity:** The Jim G has separate tanks for oil and water transport. It stores up to 18,429 gallons of fuel, 1,200 gallons of potable water, and 36,000 gallons of drill water (drill water tanks can be used for oil). It also has a cargo deck area of 1,804 square feet and a capacity of 268 tons. The maximum capacity is 296 tons.
- **Food:** Based on weight, the Jim G can carry 515 pallets of food, yielding 535,600 lbs or 267.8 tons. Based on area, the Jim G can carry 131 pallets if they are not stacked and 262 pallets if they are stacked. This results in 1801 sq. ft. The capacity for food is limited by area.
- **Water/Fuel:** The Jim G can carry a total of 55,629 gallons of water and fuel as long as the weight does not exceed 296 tons.
- **Ammunition/Repair Parts:** Based on weight, the Jim G can carry 536 pallets of ammunition and repair parts, yielding 268 tons. Based on area, the Jim G can carry 135 pallets if they are not stacked and 170 pallets if they are stacked. This results in 1800 sq. ft. The capacity of ammunition or repair parts is limited by area.
- **Throughput:** $(296 \text{ tons})(22 \text{ nm/hr})/(40 \text{ nm}) = 162 \text{ tons/hr}$. Both legs, $(296 \text{ tons})/[(40 \text{ nm}/22 \text{ nm/hr})+(40 \text{ nm}/24 \text{ nm/hr})] = 85 \text{ tons/hr}$.
- **Load/Unload:** It may be possible to carry the Sharon F on USN amphibious ships. If not, the Sharon F is transportable by heavy sea lift. However, it does not have its own ramp, and it cannot beach itself. Because it cannot beach itself, it must be able to moor alongside a pier or a floating causeway.

4.6.1.7 H-60 Helicopter

The H-60 series is a multipurpose helicopter that is capable of cargo lift. All services have this helicopter in their inventory. Figure 69 is the H-60.



Figure 69. SH-60 Seahawk.²⁸⁹

H-60 Parameter Analysis²⁹⁰

- **Speed:** 160 knots unloaded. 110 knots loaded.
- **Capacity:** The H-60 has an internal cargo area of 13 sq. ft. It has a cargo capacity of 4.5 tons. The maximum external lift capacity is 5 tons. For modeling purposes, the RST assumed that cargo will only be transported externally.
- **Food:** The H-60 can carry nine pallets of food, yielding 9,360 lbs or 4.68 tons.
- **Water/Fuel:** The H-60 can carry only one SIXCON, yielding five tons.
- **Ammunition/Repair Parts:** The H-60 can carry 5 pallets of ammunition or repair parts, yielding five tons.
- **Throughput:** $(5 \text{ tons})(110 \text{ nm/hr})/(40 \text{ nm}) = 13.75 \text{ tons/hr}$. Both legs, $(5 \text{ tons})/[(40 \text{ nm}/110 \text{ nm/hr})+(40 \text{ nm}/160 \text{ nm/hr})] = 8.15 \text{ tons/hr}$.
- **Load/Unload:** Because cargo will be carried externally, hooks and wires will be utilized.

4.6.1.8 H-53E Super Stallion/Sea Dragon Helicopter

“Developed specifically for the U.S. Navy and Marine Corps, the H-53E series is the heaviest lift helicopter in service.”²⁹¹ Figure 70 is the H-53E.



Figure 70. H-53E.²⁹²

CH-53E Parameter Analysis²⁹³

- **Speed:** 150 knots unloaded. 110 knots loaded.
- **Capacity:** The CH-53E has an internal cargo area of 225 sq. ft with a height of 6.5 ft. The maximum external lift capacity is 16 tons. For modeling purposes, the RST assumed that cargo will only be transported externally.
- **Food:** The CH-53E can carry 30 pallets of food, yielding 15.6 tons.
- **Water/Fuel:** The CH-53E can carry three SIXCON's, yielding 15 tons.
- **Ammunition/Repair Parts:** The CH-53E can carry 32 pallets of ammunition or repair parts, yielding 16 tons.
- **Throughput:** $(16 \text{ tons})(110 \text{ nm/hr})/(40 \text{ nm}) = 44 \text{ tons/hr}$. Both legs, $(16 \text{ tons})/[(40 \text{ nm}/110 \text{ nm/hr})+(40 \text{ nm}/150 \text{ nm/hr})] = 25 \text{ tons/hr}$.
- **Load/Unload:** Because cargo will be carried externally, hooks and wires will be utilized.

4.6.1.9 MV-22 Osprey

“The MV-22 Osprey is a high-speed, rotary-wing aircraft currently being produced for the Marine Corps assault role.”²⁹⁴ Figure 71 is the MV-22.



Figure 71. MV-22.²⁹⁵

MV-22 Parameter Analysis^{296 297 298}

- **Speed:** 300+ knots unloaded. 110 knots loaded.
- **Capacity:** The MV-22 has an internal cargo area of 96 sq. ft with a height of 5.4 ft. It has a cargo capacity of 9,610 lbs tons or 4.8 tons. The maximum external lift capacity is 5 tons. For modeling purposes, the RST assumed that cargo will only be transported externally.
- **Food:** The MV-22 can carry nine pallets of food, yielding 9,360 lbs or 4.68 tons.
- **Water/Fuel:** The MV-22 can carry only one SIXCON, yielding five tons.

- **Ammunition/Repair Parts:** The MV-22 can carry 5 pallets of ammunition or repair parts, yielding five tons.
- **Throughput:** $(5 \text{ tons}) * (110 \text{ nm/hr}) / (40 \text{ nm}) = 13.75 \text{ tons/hr}$. Both legs, $(5 \text{ tons}) / [(40 \text{ nm} / 110 \text{ nm/hr}) + (40 \text{ nm} / 300 \text{ nm/hr})] = 10 \text{ tons/hr}$.
- **Load/Unload:** Because cargo will be carried externally, hooks and wires will be used.

All connector alternatives were further analyzed in order to determine whether or not they would be feasible as a connector.

4.6.2 Feasibility Analysis

In order for an alternative for the connector to be feasible it must have throughput, it must be able to carry at least one SIXCON, and it must be survivable. Using these factors, the RST analyzed the different alternatives to determine feasibility. Throughput was measured as tons per hours. When calculating the throughput, the RST assumed the distance between the supply ship and the operating base was on average 40 nm. For a re-supply mission of 300 tons, if a supply ship stays on station for 24 hours, the throughput must be 12.5 tons/hr. Possessing the capability to carry one SIXCON was only an issue for the aircrafts. If an aircraft cannot carry a SIXCON, then the aircraft will be unable to re-supply the RF. A SIXCON weighs approximately five tons when full. To be safe, the minimum weight capacity should be 5.5 tons. The connector must be survivable. This was only an issue for the sea vessels. The vessel must have a steel hull for protection, and it must not bring a lot of attention to itself.

From the list of alternatives, the RST did further evaluation on their feasibility as a connector. To summarize, the connector must have a throughput of 12.5 tons/hr, be able to carry a SIXCON, and must have a steel hull if it is a vessel. The feasibility matrix for the connector can be seen in Table 19.

Alternative	Throughput	Cargo Weight	Survivability
LCAC	G	G	NG
LCU-1610	G	G	G
LCM-8	NG	G	G
LCU-2000	G	G	G
Jim G	G	G	G
Sharon F	G	G	NG
H-60	NG	NG	G
H-53	G	G	G
MV-22	NG	NG	G

G: Go NG: No Go

Table 19. Connector Feasibility Matrix.

Throughput was a problem for the LCM-8, the H-60, and the MV-22. Their throughputs were less than 12.5 tons/hr, and that did not include the time to load and unload. Having multiple H-60s and MV-22s will increase the throughput to be greater than 12.5 tons/hr, but they are at the limit when lifting SIXCON's. The Sharon F has a great throughput because of its speed, but its aluminum hull makes it more vulnerable when attacked. The LCAC has a decent throughput, but its load noise also makes it vulnerable because of the attention that it brings to itself, which was confirmed with the NECC's Technology and Strategy Department Head.²⁹⁹ The four feasible alternatives for the connector are the LCU-1610, LCU-2000, Jim G, and H-53. Table 20 provides a summary of each platform.

Alternative	Cargo Weight (tons)	Cargo Deck Area (sq. ft)	Unloaded Speed (knots)	Loaded Speed (knots)	Throughput (tons/hr)	Maneuverability	Load and Unload
LCU-1610	143	1850	12	6	14.3	Length: 135 ft Beam: 29.5 ft Max Draft: 6 ft	Bow ramp, Can beach itself, Can fit in amphibs
LCU-2000	350	2558	11.5	12	41	Length: 174 ft Beam: 42 ft Max Draft: 9 ft	Bow ramp, Can beach itself, Cannot fit in amphibs
Jim G	296.8	1825 + Separate Storage for Fuel and Water	11	11	44	Length: 126 ft Beam: 32 ft Max Draft: 10 ft 7 in	No bow ramp, Cannot beach itself, Can fit in amphibs
H-53	16	External	150	110	25	Air Space	Cargo lift

Table 20. Summary of Feasible Connectors^{300 301 302 303}

The LCU-1610, LCU-2000, Jim G, and H-53 are capable of re-supplying the RF as connectors. They have a large cargo capacity and reasonable speeds resulting in a high throughput. These feasible alternatives were further analyzed to determine any potential risk in each platform.

4.6.3 Risk Analysis

The RST performed risk analysis to identify potential areas that would affect the supply of the RF. Risk was broken down into operational availability and military capability risks. Table 21 describes each of the risk categories.

Risk Category	Description
Operational Availability	Risk that an option will preclude the achievement of operational availability target
Military Capability	Risk that an option will result in delay or failure to achieve required capability

Table 21. Types of Risk for Logistic Connectors.³⁰⁴

All of the alternatives have the risk of unavailability; however, the Jim G has the greatest risk because it is a commercial vessel. The Navy would have to lease or buy the Jim G, whereas the other platforms belong to the U.S. military. If the Jim G was purchased, then it would have to be lifted from CONUS to the AO. Another risk that exists when using non-military platforms is the lack of commonality. Different equipment and instructions can affect the operations.

Another risk is military capability risk. One capability that the connectors should have is to provide self-defense. Losing a connector has a severe impact on the success of the mission. Although the alternatives have gun mounts and other measures of self-defense, there still exists the risk of being destroyed by an attack. Another capability is adaptability to changes in the AO. AO changes affect the performance of the connectors. The length between the supply ship and the operating base has a huge impact on the connectors. If the length increases, certain connectors may not be able to adequately re-supply the RF. Further analysis should then be performed to take into account fuel consumption and endurance/range of the connectors.

4.6.4 Logistic Connector Configuration

To satisfy the needs of moving materiel up the river the RST determined that each feasible alternative would require a unique loading style in order to move the maximum amount of materiel in accordance with priority of need at the base alternative.

The LCU 1610 has a maximum payload of 140 tons, cargo area of 1,850 square feet, and has no capacity for storing liquids internally other than for its own engine and crew consumption. The LCU 2000 has a maximum payload of 350 tons, cargo area of 2,550 square feet, and has no capacity for storing liquids internally other than for its own engine and crew consumption. The SEACOR Jim G has a maximum payload of 320 tons, cargo area of 1,825 square feet, and has capacity for storing liquids internally other than for its own engines and crew consumption. Table 22 shows the different configurations possible for each of the basing alternatives.

LCU 1610 Configurations										
	Total ft ²	Maximum Tonnage	Sixcon ft ²	Total Sixcon	Empty Sixcon Weight (tons)	Number of Fuel Sixcon	Number of Water Sixcon	Number of Waste Sixcon	Pallet ft ²	Materiel Tonnage
Waste Carrying	1850	140	52	54	70.2	21	17	16	13.33	69.8
Non Waste Carrying	1850	140	52	45	58.5	25	20	0	13.33	81.5
<i>Max Capacities</i>										
	Fuel gals.	Fuel Tons	Water gals.	Water Tons	Waste gals.	Waste Tons	Pallets	Pallet Tons		
Waste Carrying	18900	63.41	15300	63.50	14400	64.8	33	16.75		
Non Waste Carrying	22500	75.49	18000	74.70	0	0	53	26.90		
LCU 2000 Configurations										
	Total ft ²	Maximum Tonnage	Sixcon ft ²	Total Sixcon	Empty Sixcon Weight	Number of Fuel Sixcon	Number of Water Sixcon	Number of Waste Sixcon	Pallet ft ²	Materiel Tonnage
Waste Carrying	2558	350	52	80	104	0	55	25	13.33	246
Non Waste Carrying	2558	350	52	80	104	0	80	0	13.33	246
<i>Max Capacities</i>										
	Fuel gals.	Fuel Tons	Water gals.	Water Tons	Waste gals.	Waste Tons	Pallets	Pallet Tons		
Waste Carrying	70000	234.85	49500	205.43	22500	101.25	35	17.76		
Non Waste Carrying	0	0.00	72000	298.80	0	0	35	17.76		
SEACOR Configurations										
	Total ft ²	Maximum Tonnage	Cargo Deck Tonnage	Ballasting Gals.	Ballasting Tons	Pallet ft ²	Materiel Tonnage			
Waste Carrying	1825	320	180	40000	134.20	13.33	320			
Non Waste Carrying	1825	320	180	40000	134.20	13.33	320			
<i>Max Capacities</i>										
	Fuel gals.	Fuel Tons	Water gals.	Water Tons	Waste gals.	Waste Tons	Pallets	Pallet Tons		
Waste Carrying	54000	181.17	23800	98.77	17300	77.85	35	17.76		
Non Waste Carrying	70000	234.85	23800	98.77	0	0	35	17.76		

Table 22. Connector Configurations

The first configuration concerns the movement of materiel up the river as well as reserving space on board the logistic connector for the movement of waste water down the river on a daily basis. The number of SIXCON's for the LCU 1610 and LCU 2000 is dependent on the deck space of the craft and the ability to stack the SIXCON's on top of each other. The configuration was two SIXCON's stacked. The total number of SIXCON's on any configuration is not the total amount of materiel that was carried. The number of each type of SIXCON was used to prioritize the loading of materiel. First priority was fuel followed by water and then pallets of food, ammunition, and repair parts. The platform was loaded by priority until maximum capacity of materiel tonnage reached. The second configuration of each logistic connector was the ability to move fuel, water, and pallets up the river but only solid waste such as cardboard and plastics that has been palletized down the river.

4.7 REPAIR GROUP

4.7.1 Analysis of Alternatives

For this study, the RST used the nominal group technique (NGT), whereby the screening of alternatives involved “a discussion and clarification” of ideas which led to a “prioritization” of alternatives.³⁰⁵ This of course, was triggered by an initial question from one of the study's key clients, CAPT David Balk, USN, Naval Expeditionary Combat Command's Strategy and New Technology Officer, “How should we do maintenance?”³⁰⁶

For the purposes of scenario development, this trigger question³⁰⁷ was placed within the bounds of maintaining a small footprint, which this study defined as, “the amount of personnel, spares, resources, and capabilities physically present and occupying space at a deployed location.”³⁰⁸ From this point, the RST used the NGT to develop the following system level objectives, for which our alternatives had to meet: minimize footprint, minimize mechanic to equipment ratio, maximize acceptable operational availability (A_o) and minimize acceptable cost in terms of dollars per man and maintenance dollars per deployment. Considering these system level requirements, the

bounds of the scenario, and most importantly, the needs of the client, the RST formulated three distinct alternatives.

For the first alternative, the RST modified the existing maintenance system by increasing the number of maintenance personnel, assuming that all personnel had a “jack-of-all-trade” baseline skill set, from nine to an optimal number which was determined through modeling and analysis. It is also important to note that the initial decision to look into this alternative was primarily due to a point paper written by Construction Mechanics (CM) Chief Petty Officer Robert Grenier in which he explains, “The optimum ratio for CM [personnel] is one mechanic-for each five pieces of [civil engineering support equipment] assigned (1:5 ratio). Obviously, many factors such as training, experience, environment, and equipment condition will cause the optimum ratio to vary.”³⁰⁹ Riverine squadrons are currently billeted nine maintainers. Based on sixty five pieces of rolling gear and twelve SURC’s, the mechanic to equipment ratio for the RST’s scenario is 1:9. This alternative also involves increasing the number of personnel of a particular skill set; that is, increasing the number of electronics technicians, enginemen, or machinist mates within the pool of maintenance men. A recent quarterly report from Raytheon Technical Services, who is under contract to provide Customer Logistics Support, which includes SURC failure reporting, showed that electronic failures made up only 5% of system failures.³¹⁰ With this in mind, the RF of 2012 will be outfitted with new and improved command, control, communications, computers, intelligence, surveillance and reconnaissance (C4ISR) equipment and capabilities which could result in a higher percentage of electronics failures over the course of a RF deployment. Therefore, the alternative of increasing the number electronics technicians, in this case, merits further analysis.

The second alternative increased the number of SURC’s deploying with the RF. This particular alternative raised concern within the RST, as it appeared to be counterintuitive to the definition of “small footprint.” With regard to preventive and corrective maintenance checks, the intent of this alternative was to ensure that an adequate number of fully mission capable SURC’s were operationally available throughout the RST. In the scenario, the SURC’s had to be surge ready, that is, while

one detachment of four SURC's was on patrol, another detachment of four SURC's would be ready to deploy in order to augment the currently deployed detachment, while one SURC remained in an alert status—adding up to 9 fully mission capable SURC's at all times. This led back to the queuing issue of multiple SURC's requiring preventive or corrective maintenance at the same time—raising the question, “Will twelve SURC's be enough?”

The third alternative involved increasing the number of maintenance facilities from one to two. The baseline for the FOB, MOB and GFS basing alternatives only has provisions for one maintenance facility (i.e., one SURC can be repaired in a maintenance facility at one time). However, there was a risk of increased mean time to repair and decreased operational availability due to multiple boats requiring repairs that could only be performed in a single maintenance facility. The intent of modeling this alternative was to determine the right number of maintenance facilities necessary to fulfill RF mission requirements while meeting both preventive and corrective maintenance needs—particularly those performed in a maintenance facility (e.g., 500-hour engine checks, Raytheon Technical Representative contractor checks, etc.).

The fourth, fifth, sixth and seventh alternatives involved the following combinations of the previously discussed alternatives:

- Fourth: Increase personnel and facilities.
- Fifth: Increase personnel and SURC's.
- Sixth: Increase SURC's and facilities.
- Seventh: Increase Personnel, maintenance facilities and SURC's.

4.7.2 Feasibility Analysis

RST could not successfully conduct a feasibility analysis on the repair system's alternatives. A feasibility analysis is conducted to eliminate the infeasible alternatives generated during the alternatives analysis. This elimination is done using a crucial element of any feasibility analysis, the requirements, which filter out infeasible alternatives. However, from discussions with Riverine Group One's Material Officer,

LCDR Frank Okata and other key stakeholders, RST learned system level requirements were not defined for the repair system. What RST did receive in regards to requirements were a list of crucial DOTMLPF type constructs that LCDR Okata felt were necessary for a squadron to efficiently conduct maintenance. These constructs included: mechanic to equipment ratio and skill sets, additional SURC's, and additional maintenance bays.

Mechanic to equipment ratio falls into the personnel aspect of the DOTMLPF solution set. According to CMC (SCW) Grenier's point paper, the mechanic to equipment ratio should be one mechanic for every five pieces of rolling gear.³¹¹ In order to meet this ration, the RF would require six additional maintenance personnel—bringing the number from 9 to 15. Currently, the RF maintenance effort is being fulfilled with a 1:8 mechanic-to-equipment ratio. This maintenance effort also includes the baseline skill sets of enginemen, machinist's mate and electronics technician. These skill sets are evenly distributed within the riverine maintenance corps; however, a recent SURC Reliability, Maintainability and Availability (RMA) report (Figure 72), from Raytheon Integrated Defense Systems, indicates that 50% of the SURC system failures were propulsion related.³¹²

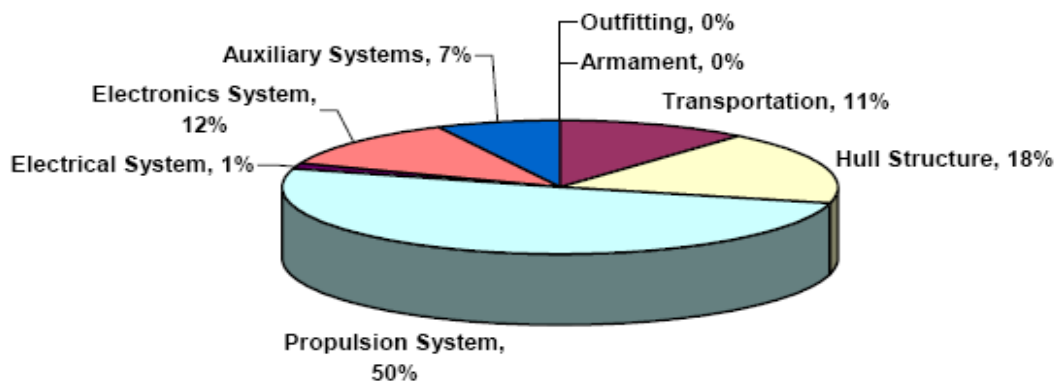

Figure 72. 2006 SURC RMA Report Percent of Failures by System

Based on the percentage of propulsion related failures, RST felt that varying both the number of personnel and their skill sets was necessary, as it was believed that the RF maintenance organization may not be optimally aligned to the types of failures that are most likely to occur. For example, the three electronics technicians may not be optimally

employed in the RF maintenance effort when only 12% of the failures are electronic in nature; whereas the machinist's mates and enginemen are being tasked with the repair of propulsion, hull, and transportation failures which make up the majority of the SURC failures.

The addition of a thirteenth SURC is an element of the material aspect of the DOTMLPF solution. The requirement according the CNA REPORT is each squadron will have 12 SURC's. However, the RST wanted to add float SURC's in order to assess the overall affect on maintenance. Since the requirement to have 12 SURC's is met, increasing the number of SURC's will not create any infeasible alternatives. In the same light, the facility aspect of the DOTMLPF solution is represented by increasing the number of maintenance bays. Currently, the manning and facilities requirements are already being met; however, key changes in the organization of the Riverine Support Unit (RSU) could help to alleviate the maintenance load placed on the RF and decrease the footprint of deployed forces.³¹³

4.7.3 Risk Analysis

RST performed risk analysis to identify areas within the repair system that would be prone to some probability of loss or chance of not achieving the overall goal of producing a more efficient maintenance system. In examining risk to the system, the RST first considered the alternatives, and then looked at the repair systems ability to meet the requirement of functionality of RF 2012. The two biggest risks the RST identified were budget and training.

Budget has the greatest impact on the RF maintenance system based on the alternatives of adding additional boats or personnel. With regard to personnel, there may not be funds available to pay for the additional sailors. "The bottom line: a 322,000-sailor Navy by 2013, 27,000 fewer than today's active force and 54,000 less than in 2004. The bulk of the latest proposed cuts, about 19,000 sailors, will take place over the next two years."³¹⁴ For this study, the risk of personnel cuts by 27,000 billets, while increasing the number of personnel in specialty occupations, increases the likelihood that there will not be enough personnel to meet the demand for the three riverine groups.

Furthermore, along with the cost of additional personnel, the cost of additional maintenance bays and boats was considered. The Navy will receive 24 SURC's as the USMC starts to hand over the riverine mission. In addition, the Navy requested in its 2008 emergency war budget, funds to buy 12 additional boats, 8 SURC's and 4 specialty boats, bringing the total number of boats for the riverine force to 36, 12 for each squadron (site).³¹⁵ There is no funding for additional float SURC's, therefore there is a possibility that the Navy will not be able to purchase float boats as outlined in this study. The maintenance bay will present less risk in that literally four stakes and a tarp will suffice. However for this study we will use 25 X 40 ft Shop Vehicle Maintenance tent used by the Seabees, which was the smallest tent within the inventory, capable of meeting the dimensions of the SURC. Again, LCDR Okata recommended one tent, so the requirement has already been met and no alternatives could be eliminated.

Training is another risk. Will there be enough properly trained mechanics to support the riverine squadron? With the addition of added command and control hardware and software, the RF will require additional skilled labor to keep equipment functioning properly. Which raises the following issue: will the current three skill sets, EN, MM, and ET, be adequate or should more be included? Based on the current force structure and historical data on SURC maintenance³¹⁶ the answer is, "Yes," but it is possible this may be incorrect. The chapter on modeling and analysis describes in further detail the effect of the aforementioned alternatives on the RF.

The overall risk assessment for this analysis is medium probability medium impact. The largest contributor to this assessment is budget, i.e. allocation of money to pay for additional personnel and boats. Essentially, since the Navy is conducting a reduction in personnel levels and based on the current purchase plan for additional SURC's there may not be enough personnel or boats to execute our recommendations as laid out in this study. Training presented low risk and low probability. The Navy is drawing down its personnel in order to pay for modern equipment. Therefore many of the highly skilled jobs will be retained so it can be expected that maintenance personnel may experience a restructuring within their field, but no major shortage of personnel.

4.8 FORCE PROTECTION GROUP

4.8.1 Analysis of Alternatives

The RST used the systems engineering design process to create sub-functions and objectives for a complete FPS. For the analysis of alternatives, the problem was scoped further to those physical components that provided the functions associated with denying the threat for specific scenarios. The drivers for these architectures were the potential threats to the RF's base of operations. Due to time constraints, the RST could not examine every threat facing the RF at the base of operations, but the RST examined a range of threats from a less capable to a more capable enemy.

The operational setting in this report highlighted an insurgent force that was in the process of acquiring more capability through the influx of weapons. Assuming the RF deploys to the area before the insurgents have gathered a significant capability, the RF would likely face a lower level insurgency force only capable of smaller, harassing attacks. If the MIO operation proves unsuccessful throughout the course of the deployment, then the insurgent force could develop a significant capability and, likewise, attempt more significant attacks with more people and weapons.

The RST chose a mortar assault as the lower-level attack and a commando raid and boat assault as examples of higher level attacks. The same sub-functions of denying applied across each of these types of attack; however, the physical architectures for each attack were different. Each of these attacks was linked to alternative physical architectures using morphological charts. Table 23 is the morphological chart for denying in the mortar scenario.

Physical Architectures	Deny (Mortar)				
	Detect to Identification	Engage	Block	Conceal	Move
Baseline	none	none	Sandbags	Base Configuration, Sandbags	Ship's propulsion (platform specific)
Mortar and UAV	UAV	Mortar	Sandbags	Base Configuration, Sandbags	Ship's propulsion (platform specific)
Mortar and Counter-fire	Counter-fire radar	Mortar	Sandbags	Base Configuration, Sandbags	Ship's propulsion (platform specific)
Mortar, Counter-fire Radar, and UAV	Counter-fire radar and UAV	Mortar	Sandbags	Base Configuration, Sandbags	Ship's propulsion (platform specific)

Table 23. Deny Mortar Threat

The RF has no assets in its baseline that can detect and engage a mortar threat aside from host nation personnel providing perimeter security out to the expected range of enemy mortar fire. However, as these host nation land forces were not a part of the RF, they were not considered in the baseline architecture. To serve the blocking function, the RF has at its disposal sandbags, which could block mortars from affecting their targets by hardening them. The baseline achieves the conceal function only for the FOB alternative through the configuration of the tent structures. At the FOB, for example, the berthing tents were placed around the TOC to hide it from the enemy. Finally, the move function can only be achieved for the MOB basing alternatives, as the FOB cannot rapidly move the critical structures during the length of a mortar assault.

The additional components added to create the other physical architectures were a mortar, counter-fire radar, and UAV. A discussion of the specific make and model of these components occurs later in this section. Table 24 is the morphological chart for denying the commando raid threat.

Physical Architectures	Deny (Commando Raid)				
	Detect to Identification	Engage	Block	Conceal	Move
Baseline	Perimeter personnel	RF weapons (see write-up below)	Sandbags, Concertina Wire	Base Configuration, Sandbags	N/A
Baseline plus Sensor Fence and Mortar	Perimeter personnel and Sensor Fence	Baseline weapons, Mortar	Sandbags, Concertina Wire	Base Configuration, Sandbags	N/A
ROSAMs	ROSAM sensor package with human in the loop	RF weapons mounted on ROSAM	Sandbags, Concertina Wire	Base Configuration, Sandbags	N/A

Table 24. Denying Commando Raid Threat

The baseline architecture for the detect to identify and engage functions consisted of RF personnel and their weapons positioned along the perimeter of the base. Concertina wire and sandbags were used for the baseline architecture to accomplish the block function. Like the mortar attack, the base configuration and sandbags could also be used to conceal the critical structures of the base. The move function did not apply for the commando raid because the commando raid is a landward attack and could only be conducted against a FOB. The Sensor Fence and Mortar architecture was added to the baseline and provided additional components to achieve the detect to identification and engage functions. The Remote Operated Small Arms Mount (ROSAM) architecture

replaced the personnel required to handle the RF weapons on the perimeter with ROSAMs. The ROSAMs are outfitted with a sensor package that provides detection to identification with human interaction. Table 25 is the morphological chart for denying the boat attack threat.

Physical Architectures	Deny (Boat Attack)				
	Detect to Identification	Engage	Block	Conceal	Move
FOB					
Baseline	Perimeter personnel	RF weapons (see write-up below)	Sandbags, Concertina Wire	Base Configuration, Sandbags	N/A
Baseline plus Water Barrier	Perimeter personnel	RF weapons	Sandbags, Concertina Wire, Water Barrier	Base Configuration, Sandbags, Water Barrier	N/A
Water Barrier and ROSAMs	ROSAMs sensor package with human in the loop	RF weapons mounted on ROSAM	Sandbags, Concertina Wire, Water Barrier	Base Configuration, Sandbags, Water Barrier	N/A
Baseline plus Water Barrier and Patrol Boat	Perimeter personnel and personnel on Patrol Boat	RF weapons and Patrol Boat Weapons	Sandbags, Concertina Wire, Water Barrier	Base Configuration, Sandbags, Water Barrier	N/A
ROSAM plus Water Barrier and Patrol Boat	ROSAMs and personnel on Patrol Boat	RF weapon mounted on ROSAM and Patrol Boat weapons	Sandbags, Concertina Wire, Water Barrier	Base Configuration, Sandbags, Water Barrier	N/A
MOB					
RCSS	Ship's Radar and Sensors	Ship's weapons	Ship's Hull	Ship's Hull	Ship's Propulsion
RCSS plus Patrol Boat	Ship's Radar and Sensors plus Personnel on Patrol Boat	Ship's weapons and Patrol Boat weapons	Ship's Hull	Ship's Hull	Ship's Propulsion
Nobriza and Barge	Ship's Radar and Sensors	Ship's weapons	Ship's Hull	Ship's Hull	Ship's Propulsion (Nobriza only)
Nobruza and Barge plus Patrol Boat and Water Barrier	Ship's Radar and Sensors	Ship's weapons and Patrol Boat weapons	Ship's Hull and Water Barrier	Ship's Hull and Water Barrier	Ship's Propulsion (Nobriza only)

Table 25. Denying Boat Attack Threat

Much like the baseline defense for the commando raid at the FOB, the detect to identification and engage functions are accomplished by the perimeter personnel outfitted with the RF's weapons. Here, of course, the personnel are those employed along the banks of the river. The next architecture saw the addition of the WhisprWave water barrier which was described later in the section. The barrier provided more to achieve the blocking and concealing functions. The water barrier and ROSAM architecture replaced the personnel on the banks of the river with ROSAMs. The final two architectures for the FOB FPS against a boat attack had Patrol Boats (PB). The PB's provided extended detection and identification and were also outfitted with weapons to provide further engaging capability.

The MOB architectures considered were the RCSS and the Nobriza and Barge combination. The RST limited the analysis of the FPS for the MOB architectures to the RCSS and the Nobriza and barge configurations because the capabilities of the RCSS, Endurance, and the KD 1505 were approximately equivalent. The radars and weapon systems available to these MOB combinations is discussed later in this section.

4.8.1.1 Sensors

Human

As advanced as some sensors have become, there are few sensor packages as effective as humans. Humans fulfilled all of the functions of a good sensor in that they detected threats, located threats, tracked threats, and identified threats from otherwise benign targets. The baseline for each of the alternative systems relied heavily on the use of humans as sensors. The 17 personnel already assigned to security for the riverine squadron were augmented with Maritime Expeditionary Security Force (MESF) personnel to serve as the primary manning for the FOB FPS. The force assigned was dictated by the architecture of the FPS, but contained enough personnel to allow for three eight-hour rotations. The security personnel for the MOB architectures included the 17 security personnel plus the crew for each of the craft alternatives.

For the FPS, the use of humans as sensors not only applies to the personnel that are conducting patrols on land and on small craft in the water, but also to coalition forces and the local population. The Indonesian Army and their informants provided warnings of impending threats far beyond the RF's sensor range. In Honduras, for example, U.S. forces leveraged the local villages surrounding their own encampments to provide information about enemy activity.³¹⁷

Night Vision Devices

The RF personnel were outfitted with night vision devices such as night vision goggles (NVG's) and night vision binoculars (NVB's), which greatly enhanced their capability to operate in low light conditions. When enhanced with infrared (IR) illuminators, personnel protecting the base were able to survey the surrounding areas with limited or no ambient light. The personnel of the RF were already equipped with NVG's, so this equipment is a part of the baseline sensor package. The RST modeled the AN/PVS-7 currently used by the U.S. Army and the U.S. Marine Corps for our analysis.

Sensor Fences

The SensorFence is simply a wire mesh fence with geophones and accelerometers attached. The geophones detect vibrations on the fence and acoustic signatures up to 50 feet away. The same components can also attach to concertina wire in the same fashion. The SensorFence was developed by the Applied Research Laboratory in Penn State University to create a low cost alternative for making high tech fences. Figure 73 is a picture of a sensor fence node.



Figure 73. SensorFence³¹⁸

Electro-Optics and Infrared Sensors

This category of sensor includes thermal imagers, laser rangefinders, and laser designators. It is an important category of sensors because it performs the whole range of functions from detection to identification.

Thermal imagers pick up infrared signatures which targets inevitably emit. Because of their ability to “sense” and detect targets both in the day and night, they serve to enhance base protection as well as to conserve manpower by providing 24/7 continuous surveillance for perimeter defense. When deployed along the river, on boats or unmanned surface vessels, they increase the capability of the crew to detect, locate, identify, and track targets.

Laser range finders and designators are essential in providing accurate fire to neutralize threats at long distance, and therefore reducing the chances of damage to coalition property and friendly fire. Laser rangefinders provide commanders of crew-served weapons and mortar counter-fire batteries the ability to accurately identify the target range and, therefore, effectively direct fire. Laser designators, on the other hand, are useful target indicators for missiles and aircraft providing close air support, as well as troops wearing NVG’s.

There are currently several sensor systems that are a combination of thermal imagers, laser range finders, and laser designators. The RST chose to look at these combinations of sensors in a few different systems to avoid integration issues that arise from using separate sensors. For the FPS, there were different packages of these systems for different platforms and basing alternatives.

To provide increased surveillance for the FOB, the RST used FLIR’s ThermoVision Sentry II system. This system does not contain a laser rangefinder or designator, but provides the continuous coverage and dual fields of view at 20 and 5 degrees.³¹⁹ The Sentry II can also slave itself to other sensors to create an autonomous and shared network of sensors. Figure 74 is a picture of the Sentry II.



Figure 74. ThermoVision Sentry II³²⁰

FLIR's SeaFLIR III system is the newest version of a combination system that can provide a thermal imager, laser rangefinder, and laser pointer. The sensor also has an auto-track function to allow the user to easily remain "locked" onto targets.³²¹ These sensors are currently being outfitted for SURC's although there is still some uncertainty about how many craft will obtain them.³²² For the purpose of analysis, the SEAFLIR III sensor system was outfitted on the PBL and the RF's USV, the Sea Fox. Figure 75 is a picture of the SeaFLIR III.



Figure 75. FLIR's SeaFLIR III³²³

The Mk 46 MOD 1 Optical Sight System (OSS) is the sensor system outfitted for the RCSS. This system currently serves as a thermal imager and laser rangefinder, with an additional laser designator under development.³²⁴ The Mk 46 MOD 1 OSS is used on all U.S. Navy Arleigh Burke Class Destroyers as integrated with the ship's MK 34 weapon system. "The MK 46 OSS enables 24-hour surveillance, intelligence gathering and reconnaissance."³²⁵ Figure 76 shows the MK 46 MOD 1.



Figure 76. Mk 46 MOD 1³²⁶

Radars

Radar deployed along the river enables continuous surveillance, monitoring and tracking of the boats along the river. Suspicious boats can be detected from at least a couple of miles away and this allows preventive actions to be taken to apprehend the suspects before they can approach the base close enough to cause damage and injury.

The radar operated by the RCSS is the AN/SPS-67. The "AN/SPS-67 is a short-range, two-dimensional, surface-search/navigation radar system that provides highly accurate surface and limited low-flyer detection and tracking capabilities."³²⁷ The latest version, the AN/SPS-67(V)3 (Figure 77)"provides digital moving target indication, automatic target detection and track-while-scan for surface targets."³²⁸



Figure 77. The AN/SPS-67 Radar³²⁹

The use of a counter-fire radar also served as an improvement to any of the basing alternatives. Despite the excellent range of many sensors, the fact still remains that in operating areas where there is dense jungle, target identification can be incredibly difficult. There is the possibility in these instances that the enemy may be able to employ an indirect fire weapon before being detected. The typical indirect fire weapon available to insurgent type forces is some form of mortar. Counter-fire radars represent an excellent capability to locate the source of an enemy's indirect weapon, such as a mortar, and ensure that the enemy is not able to fire a second time. The RST chose the Lightweight Counter Mortar Radar (LCMR). The LCMR was originally developed for the Special Operations Command, but was employed for Operation Iraqi Freedom as a Limited Procurement Urgent Capability.³³⁰ The radar used in the beginning of the conflict, the Q-36 Firefinder, is limited in its searching capability to only 90 degrees at a time. Insurgents who could get close enough to the radar would simply fire when the azimuth was not facing them.³³¹ The LCMR's continuous 360 degree search was procured to supplement the more accurate Q-36. The LCMR is currently limited to a 100 meter error for target location at five kilometers, but the Army is seeking improvement to make the system accurate to 25 meters at this distance, which would allow counter-fire in populated environments.³³² Figure 78 is a picture of the LCMR.



Figure 78. The Lightweight Counter-Mortar Radar (LCMR)³³³

4.8.1.2 Weapons

The potential weapons outfit of the RF is large. A list of all potential weapons available to the squadron in the different baseline packages is listed below. The RST used the FOB and feasible MOB alternatives in these weapons packages.

Command and supporting element arms

- 65- M16-A3 service rifles
- 9- M203 Grenade Launchers
- 6- 12 GA Mossberg 500A2 shotguns
- 65- M9 9 mm pistols
- 9- M240B 7.62 mm machine guns
- 14- Mk43 7.62 mm machine guns
- 7- M2 .50 cal machine guns
- 4- Mk19 40 mm auto grenade launchers

Security Detachment Arms (FOB only)

- 72- M9 9 mm pistols
- 27- M16-A3 service rifles

- 36- M203 Grenade Launchers
- 49- 5.56 mm MOD 727 Carbine
- 13- 12 GA Mossberg 500A2 shotguns
- 2- Mk21 rifles
- 10- M240B 7.62 mm machine guns
- 9- M2 .50 cal machine guns
- 5- Mk19 40 mm auto grenade launchers

Detachment arms (x3 for total mission element)

- 53- M16-A3 service rifles
- 10- M203 Grenade Launchers
- 10- 12 GA Mossberg 500A2 shotguns
- 2- Mk21 rifles
- 53- M9 9 mm pistols
- 8- M240B 7.62 mm machine guns
- 10- M2 .50 cal machine guns

*4- SURC's equipped with

- 1 Mk43 7.62 mm machine guns
- 1 M2 .50 cal machine guns
- 1 Mk19 40 mm auto grenade launchers

(There is also on additional spare of each of these weapons per every four

SURC's)

RCSS

- 2- Mk38 25 mm Chain Guns
- Mk15 CIWS
- 8- Universal gun mounts for chosen configuration of command and supporting element weapons.

Nobriza + Barge

- Mk19 40 mm grenade launcher
- double barrel .50 cal machine guns
- multiple small arms

(Barge may include weapons mounts where necessary)

Mortar

There are two mortar systems the RST considered. The first was the M120 120 mm mortar. This mortar contains significant firepower with a 70 meter killing radius and a range from 166 meters to 7200 meters and requires a crew of 5.³³⁴ The M120 weighs 319 lbs and tows on a trailer behind a HMMWV. Figure 79 is a picture of a 120 mm mortar.



Figure 79. M120 120 mm Mortar³³⁵

Precision Guided Mortar Munition(PGMM)

The PGMM is a laser-guided 120 mm mortar cartridge capable of defeating enemy personnel under strict protective cover such as buildings and armored vehicles with low collateral damage. Once the round is in flight, onboard sensors and processors calculate the munitions' position and, several seconds later, track the laser

pointed on a specific target provided by a forward observer. The PGMM's accuracy can remain as well as 1m within specified point guided by the laser.³³⁶ Such rounds, when used with either the M120 or the Dragon Fire II, enhanced the accuracy of the weapon. Figure 80 is the PGMM.



Figure 80. Precision Guided Mortar Munition (PGMM)³³⁷

The performance characteristics of the weapon systems are given in Table 26.

Weapons	Yards			Sustained Rate of Fire (rds/min)
	Min	Effective	Max	
M-16 A2/A3 5.56 mm Assault Rifle	0	600 (point target)	4000	45
M240B 7.62 mm Heavy Machine Gun	0	2000	4100	100
M249 5.56 mm Heavy Machine Gun	0	1100 (area target)	4000	85
M2 12.7 mm .50 cal Machine Gun	0	2200	7500	30-84 (rapid rate of fire)
Mk 38 25 mm chain gun	0	3000		175 (automatic)
Mk 15 CIWS	0	classified		4500
M203 40 mm Grenade Launcher	34	165	440	
M120 120 mm Mortar	220	7900		16 (burst) 4 sustained

Table 26. Weapon Parameters^{338,339}

4.8.1.3 Barriers

Concertina, Sandbags, and Berms

The RST considered barrier systems on the land and water. Barriers primarily represent the physical manifestation of the functions blocking and concealing, but they can also serve as a deterrent. Currently, the only barrier system the RF deploys with is concertina wire in conjunction with berms and sandbags the Seabees can construct with soil. Many times barriers are constructed using material found in the local area. For the purposes of analyzing alternatives, however, the RST only considered the use of concertina wire and two berms to protect fuel as the baseline barriers. Figure 81 is a

triple layer configuration of concertina wire used by the RST and Figure 82 is a diagram of a berm.

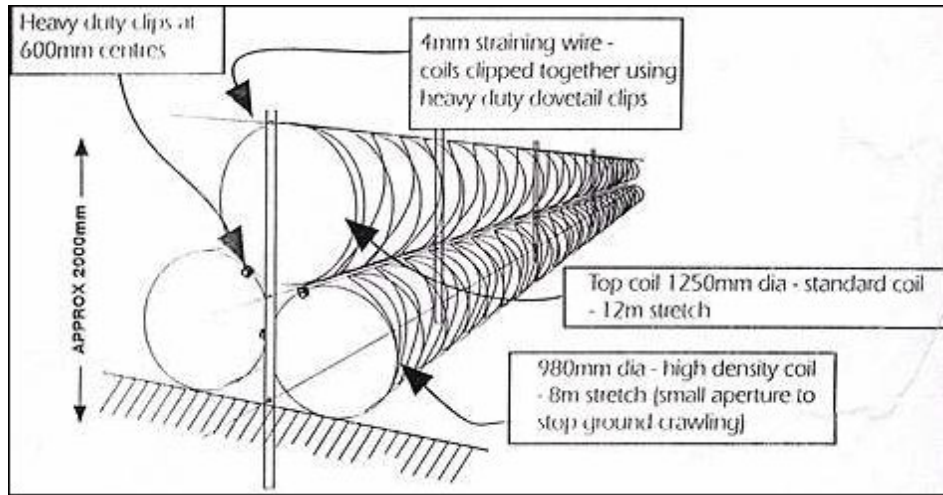

Figure 81. Triple Concertina Wire Fence³⁴⁰

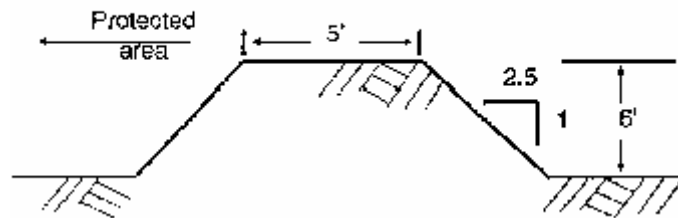

Figure 82. Berm Configuration³⁴¹

Floating Barriers

To advent the baseline concertina wire, there are a multitude of water barriers that could be employed around the FOB to prevent crafts from entering the area of operations. Some barrier systems allow other items to be constructed on them, such as fences and sensor equipment. The WhisprWave Corporation has developed a variety of barriers for the purposes of force protection. Their Rapidly Deployed Small-Craft Intrusion Barrier (RD-SCIB) was selected as the barrier of choice because it can be

deployed easily and provides the necessary protection against the threat of crafts. Figure 83 demonstrates the additions of a sign and a fence system on WhisperWave models.



Figure 83. Configurations of enhanced Whisper Wave Models³⁴²

Land Barriers

The U.S. Air Force and Marine Corps are currently using Geocell Systems' Rapid Deployment Fortification Wall (RDFW) for force protection measures.³⁴³ The RDFW is a series of stackable plastic cells that can be filled with soil in a variety of configurations to essentially replace sand bags in a less labor intensive manner. In a recent test against a series of 40 lb detonations of C4, the RDFW was reduced from a 42 inch wall to a 31.5 inch wall. "With RDFW, a crew of 6 laborers and one equipment operator can build a wall 100 feet long, four feet wide, and four feet high in one hour. An equivalent sandbag wall requires 35 laborers over 19 hours to construct."³⁴⁴ The RDFW could not only be used to construct barriers, but also serve as flood barriers or provide improved roads in muddy conditions, which are useful in a riparian environment. Figure 84 shows a front loader dropping soil into the RDFW.



Figure 84. The Rapid Deployment Fortification Wall³⁴⁵

4.8.1.4 Carrier Platforms

Light Patrol Boat (PBL)

“The Light Patrol Boat (PBL) is a lightly armed Boston Whaler type craft with no armor. This craft is constructed of fiberglass with reinforced transom and weapons mount areas. It is powered by dual outboard motors and is highly maneuverable. It is useful in interdicting a lightly armed adversary but should not be used to engage a heavily armed or well organized enemy. It functions effectively in policing actions, harbor control, diving and surveillance operations, riverine warfare, drug interdiction, and other offensive or defensive purposes.

The weapon mountings can include .50 caliber heavy machine guns or 7.62 mm machine guns mounted on 180-degree mounts, providing an effective weapon employment in any direction. Due to its unique hull design, the PBL is excellent for the riverine environment, allowing it to operate in virtually any water depth. Its two low-profile engines are capable of providing eight hours of continuous operation at a fast cruise speed of 25-plus knots. It displaces 6,500 lb. fully loaded and is transportable via its own trailer, helicopter sling, or C-130 aircraft. Normal crew size is three personnel.”³⁴⁶ Figure 85 is a picture of a PBL.



Figure 85. Light Patrol Boat³⁴⁷

HMMWV

The HMMWV (High-Mobility Multipurpose Wheeled Vehicle) is a light, highly mobile, diesel-powered, four-wheel-drive vehicle equipped with an automatic transmission. Based on the M998 chassis, using common components and kits, the HMMWV can be configured to become a troop carrier, armament carrier, S250 shelter carrier, ambulance, TOW missile carrier, and a Scout vehicle... All HMMWV's are designed for use over all types of roads, in all weather conditions and are extremely effective in the most difficult terrain. The HMMWV's high power-to-weight ratio, four-wheel drive and high ground clearance combine to give it outstanding cross-country mobility.³⁴⁸

USV

The USV selected for analysis in the FPS by the RST was the Sea Fox designed and built by Northwind Marine. "The Sea Fox is a purpose-built medium USV platform with an aluminum hull and a 220 horsepower heavy fuel (diesel of JP-5) engine powering a water jet propulsion system."³⁴⁹ The Sea Fox is 5 meters long and because of its powerful engine, "has speed, maneuverability, and range comparable to a SURC."³⁵⁰ The Sea Fox has a maximum capacity of 1000 pounds and is currently outfitted with a

speaker system to enable communication through the USV as well as a variety of sensor packages to include “infrared/white light spotlights, infrared/thermal scanners, infrared/radar launch detectors, and surface scanning (navigational) radar, to meet specific mission requirements.”³⁵¹ The Sea Fox does not currently carry weapons, however, but could possibly employ them in the future. Figure 86 is a picture of the Sea Fox.



Figure 86. The Sea Fox USV³⁵²

UAV

Complimenting the Sea Fox is ONR's lightweight UAV, the Silver Fox. Weighing in at 20 pounds, the \$50,000 Silver Fox is powered by an off-the-shelf 0.91 cubic inch 4-stroke model aircraft engine, has a ceiling of 1,000 feet, a cruising speed of 60 knots and an endurance of 10 hours when operating on 87 Octane 50:1 mixed gas. Its modular construction allows it to be broken down into several components which can all be transported in a case (dimensions: 60"x14"x15") equivalent to an oversized golf bag.³⁵³

The Silver Fox currently carries a maximum payload of 4 pounds and can be integrated with the Sea Fox, so the Silver Fox can provide detection at longer ranges and follow up with closer inspection by the Sea Fox.³⁵⁴



Figure 87. Silver Fox UAV³⁵⁵

Remote Operated Small Arms Mount (ROSAM)

The Remote Operate Small Arms Mount (ROSAM) (Figure 88) was issued a type classification as the Mk49 MOD 0 Gun Weapon System as of December 19, 2005.³⁵⁶ The Mk49 can mount a variety of weapons already in use, including the M2HB .50 cal machine gun, the GAU-17 7.62 mm Minigun, and the Mk19 40-mm grenade launcher.³⁵⁷ Some of the attributes listed for the system are: “stabilized, 2-axis mount, n x 360 degree traverse, -20 to +60 degree elevation range, lightweight: less than 250 lbs, maritized and ruggedized for demanding SOCOM applications, crew serviceable in case of electrical failure, integrated fire control computer, sophisticated auto tracking capability, Navy standard power, mounting, and communications interfaces.”³⁵⁸



Figure 88. Mk49 MOD 0/ROSAM with M2HB Bushmaster .50 caliber machine gun³⁵⁹

4.8.1.5 Physical Architectures and Their Employment

Each of the architectures introduced in the morphological charts contained the components shown above in different configurations. The figures below display the locations of these components. Figure 89 shows the location of the components for mortar defense.

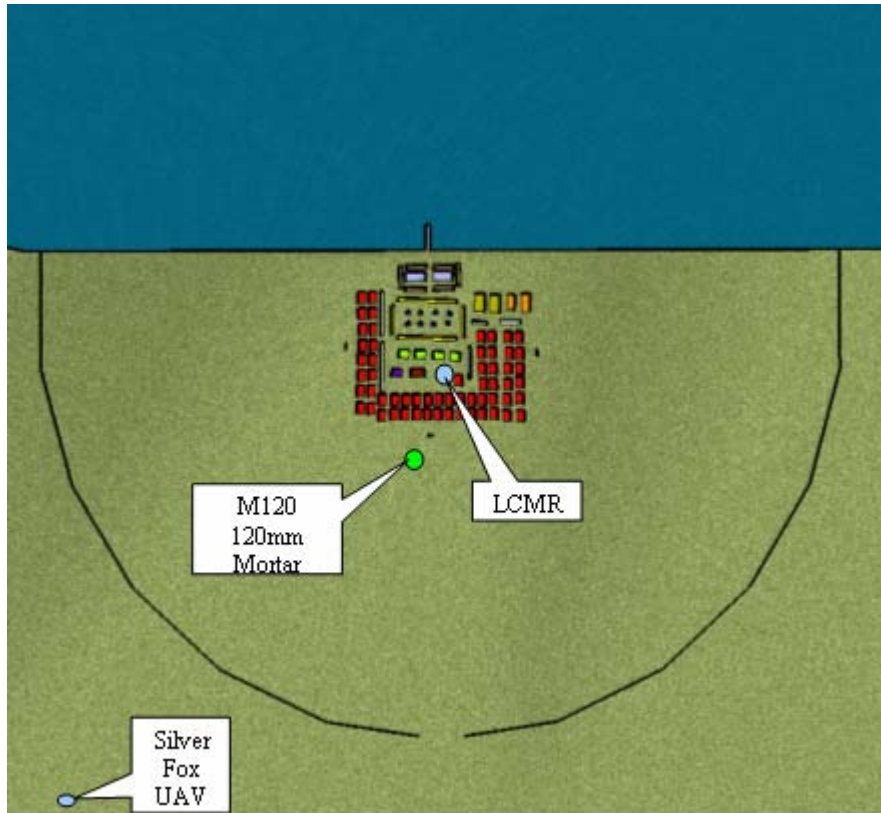

Figure 89. Mortar Threat FPS Architectures

As mentioned earlier in this section, the baseline of the RF has no assets dedicated to mortar defense. The additional architectures included either the mortar and the LCMR, the mortar and the UAV, or the mortar, the LCMR, and the UAV. Figure 90 shows the architectures dedicated to the commando raid threat.

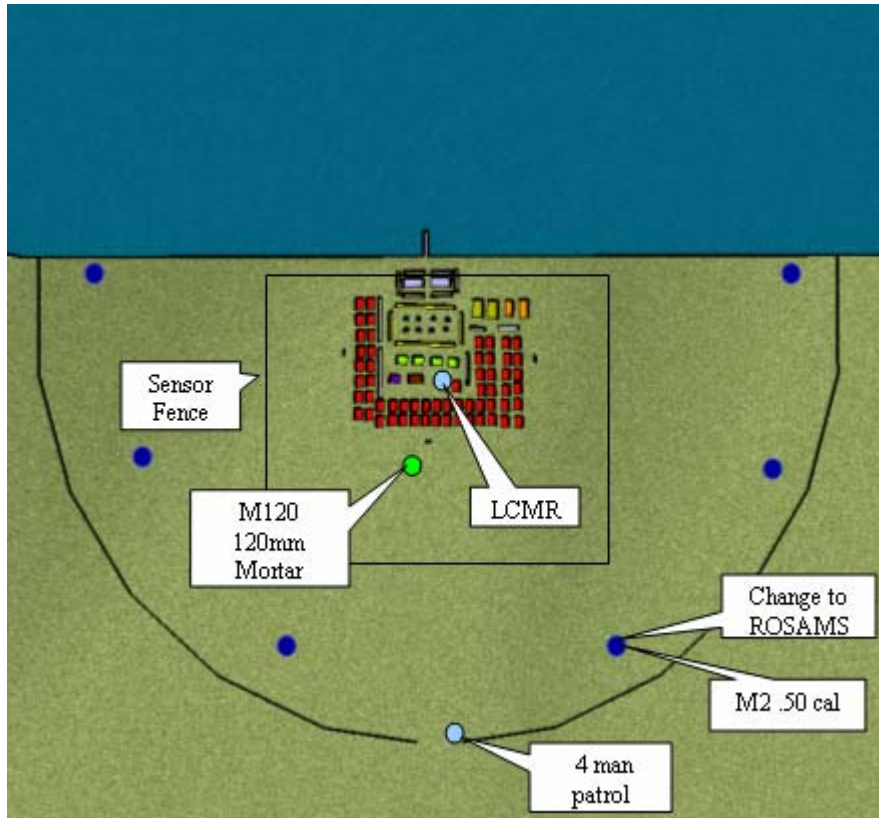

Figure 90. Commando Raid FPS

The RST configured the M2 .50 caliber machine guns at various posts with triple-layer concertina wire across the perimeter in addition to a four man patrol as a baseline. Aside from the .50 caliber machine guns, each personnel would be outfitted with the M16A3. The second architecture added the mortar and Sensor Fence. The mortar provided extra firepower against a possible assaulting force, while the Sensor Fence added an extra layer of defense and detection against infiltrations of the enemy in a raid scenario. The final architecture replaced the two personnel operating the M2 machine guns with ROSAMs. Figure 91 is the architectures used to counter a boat attack threat to the FOB.

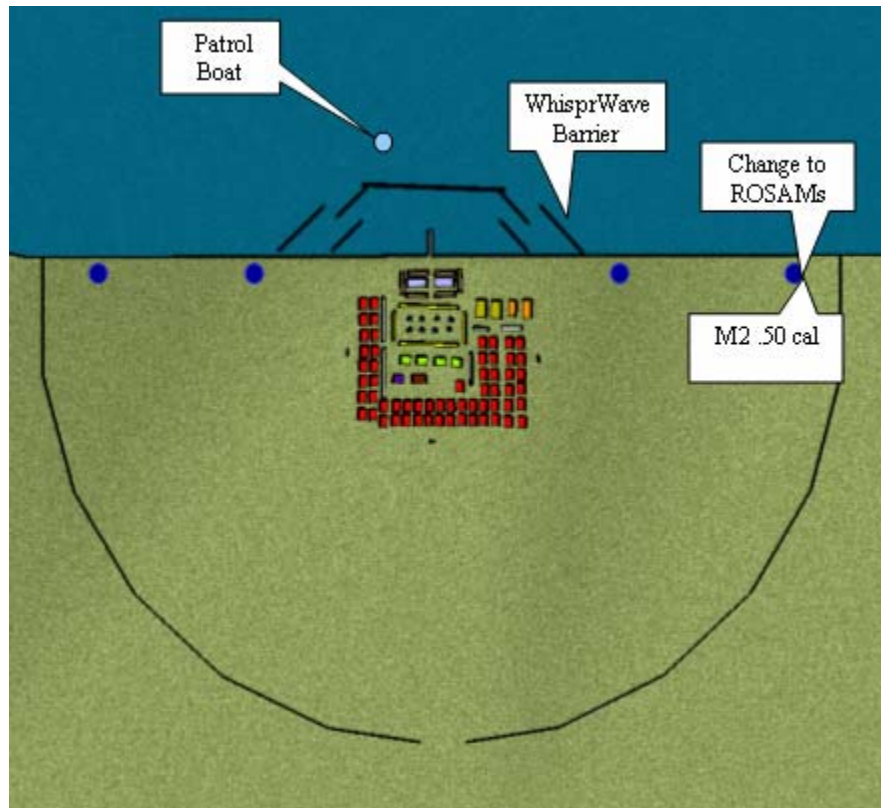

Figure 91. Boat Attack on FOB FPS

The baseline architecture for the FPS against a boat attack consisted of four two-man crews operating M2 .50 caliber machine guns along the banks of the river. The second architecture added the WhisprWave barrier. The WhisprWave was snaked so the SURCs would not be hindered in their movement from the base, and to block the line of sight of the enemy to the moored SURCs and the FOB. The third architecture replaced the crews operating the M2 .50 caliber with the ROSAMs in addition to the WhisprWave Barrier. The final two architectures had the same configuration as the second and third architecture with a PBL operating along the perimeter. Figure 92 is the configurations for the RCSS MOB against a boat attack.

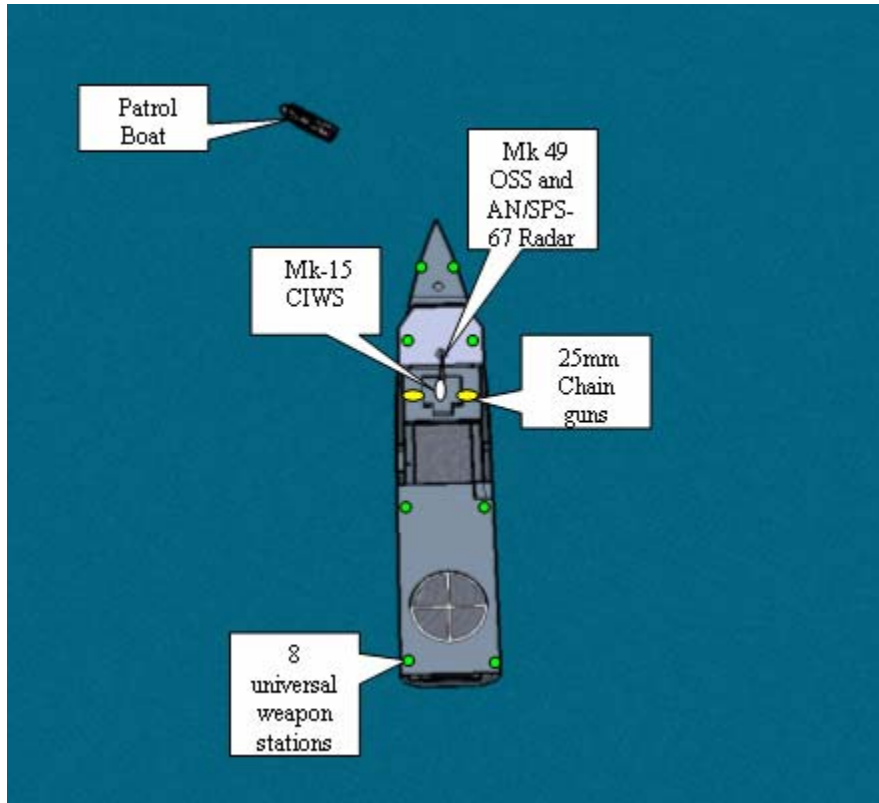

Figure 92. RCSS Boat Attack FPS

The baseline RCSS contains the Mk 15 CIWS, Mk 49 OSS, the AN/SPS-67 Radar, 25 mm chain guns, and 8 universal weapons stations. The RST decided to use eight M2 .50 caliber machine guns for the weapons stations. This made the RCSS more like the KD-1505 and the Endurance because they employ .50 cal machine guns on their weapon stations. The RST assumed the ship's crew would man all the components of the RCSS's FPS so the employment of personnel was not considered. The second architecture consisted of a PBL in addition to the RCSS. Figure 93 is the architectures for the Nabriza and Barge MOB.

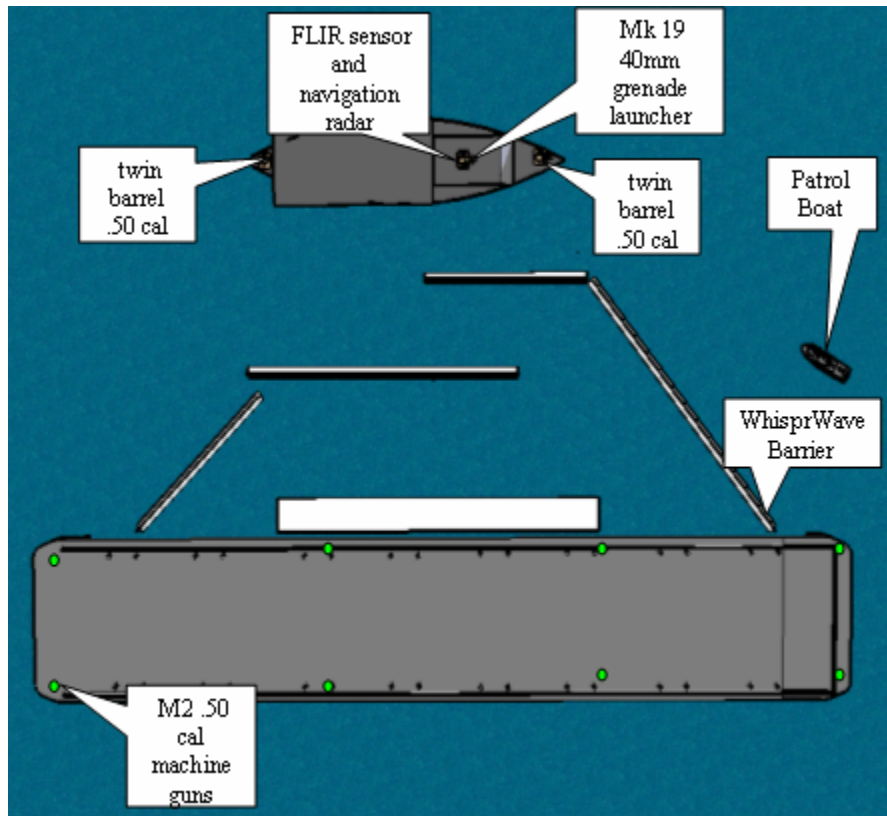

Figure 93. Nobriza and Barge Boat Attack FPS

The baseline Nobriza and Barge configuration consists of the weapons and sensors already present on the Nobriza plus whatever gun mounts might be placed on the barge. The Nobriza has twin barrel .50 cal machine guns on the forward and aft ends of the vessel and a Mk 19 40 mm grenade launcher which are all operated remotely by personnel below deck. The RST considered the baseline of weapons for the barge to be 8-.50 cal machine gun as shown in Figure 93. The detection equipment of this architecture was provided by the personnel manning the weapons on the barge and the FLIR sensor and navigation radar on the Nobriza. For this architecture, the manning requirement by the FPS was 16 people because the crew of the Nobriza operate the weapons and sensors of the Nobriza. The next architecture had the added the PBL and WhisprWave barrier. The WhisprWave barrier could be deployed off the barge because the barge was stationary in the water.

4.8.2 Feasibility Analysis

The RST was not able to conduct a feasibility analysis on the FPS because the requirements for force protection are not developed. The only limiting factor in the selection of alternatives was the time frame set by the RST of a deployable system by 2012. All of the components selected for the architecture met this requirement in that they are either currently operational, or mature in testing.

4.8.3 Risk Analysis

The RST considered a variety of risks for the FPS including technical, diplomatic, quality of life, and military capability risk. Table 27 describes each of the risk categories.

Risk Category	Description
Technical	Risk that technology will not mature.
Diplomatic	Risk of adverse reaction from or consequence to an ally or coalition partner.
Quality of Life	Risk that an option will create a real or perceived degradation in the quality of life or safety of our people.
Military Capability	Risk that an option will result in delay or failure to achieve a desired capability.

Table 27. Types of Risk for the FPS³⁶⁰

The technical risks for the FPS were derived from the use of several emerging technologies as components in the FPS architectures. Though a majority of these components are currently in the final stages of development, there still exists the risk that these technologies will not mature. The Mk46 MOD 1 is undergoing a laser designator upgrade, the LCMR is undergoing an upgrade, the Dragon Fire II is undergoing testing at the Marine Corps Warfighter Lab, and the Sea Fox, Silver Fox, and Mk49 MOD 0 weapon system will likely see upgrades in the near future.

The diplomatic risk affects the FPS in a variety of ways. The host nation may restrict the use of certain weapons such as mortars, or require the RF to decrease the amount of stand off distance between the base of operations and civilian traffic due to impeding commercial traffic on the river or land. Decreasing the stand off distance

between the base of operations and civilian traffic would decrease the assessment zone and engagement zones and lower the time the FPS has to assess potential threats and engage the enemy. Restricting the use of mortars and certain ammunition would make the FPS less capable against long range threats. As diplomacy changes, the rules of engagement may also change which could further restrict the capabilities of the FPS's components.

The risks associated with quality of life also incorporate diplomatic risk in their affects on the safety of the RF personnel. If the host nation or other coalition forces provide less support to the RF, the threat environment could shift beyond the capacity of the FPS, thereby creating an unsafe operational environment. Collateral damage, and other negative incidents, might also create a higher threat environment that could decrease the safety of RF personnel. For example, if collateral damage occurred human intelligence provided by locals might degrade, making the FPS less prepared for enemy courses of action. Meanwhile an increase in sympathy for enemy forces could increase the access and availability of weapons and increase recruits.

The risk associated with military capability address the FPS components performance in the operational environment. Some components of the FPS might be less adaptable to various climates and not operate at the same level in all geographic environments. Decreasing sensor range and detection probabilities, as well as the frequency of weapon's jamming, are examples of the potential consequences. The degree to which architecture for the FPS can adapt across a spectrum of geographic environments will determine the susceptibility of the system to these risks. Again, the threat environment could also fluctuate to a level beyond the current capacity of a given FPS. A FPS that cannot adapt to the increased demands is more at risk to failure in protecting the RF personnel.

¹⁷² Dennis M. Buede, *Engineering Design of Systems: Models and Methods* (New York: John Wiley & Sons, 2000), 215.

¹⁷³ Dennis M. Buede, *Engineering Design of Systems: Models and Methods* (New York: John Wiley & Sons, 2000), 221.

¹⁷⁴ Benjamin S. Blanchard and Wolter J. Fabrycky, *Systems Engineering and Analysis*, 4th ed. (Upper Saddle River, NJ: Pearson Education, 2006), 163.

¹⁷⁵ Benjamin S. Blanchard and Wolter J. Fabrycky, *Systems Engineering and Analysis*, 4th ed. (Upper Saddle River, NJ: Pearson Education, 2006), 163.

¹⁷⁶ Benjamin S. Blanchard and Wolter J. Fabrycky, *Systems Engineering and Analysis*, 4th ed. (Upper Saddle River, NJ: Pearson Education, 2006), 58.

¹⁷⁷ Benjamin S. Blanchard and Wolter J. Fabrycky, *Systems Engineering and Analysis*, 4th ed. (Upper Saddle River, NJ: Pearson Education, 2006), 163.

¹⁷⁸ Benjamin S. Blanchard and Wolter J. Fabrycky, *Systems Engineering and Analysis*, 4th ed. (Upper Saddle River, NJ: Pearson Education, 2006), 163.

¹⁷⁹ U.S. Department of Defense, *Joint Publication 1-02: Department of Defense Dictionary of Military and Associated Terms*, 1 March 2007 (Washington, D.C.: GPO, 12 April 2001), 465.

¹⁸⁰ Benjamin S. Blanchard and Wolter J. Fabrycky, *Systems Engineering and Analysis*, 4th ed. (Upper Saddle River, NJ: Pearson Education, 2006), 712.

¹⁸¹ Benjamin S. Blanchard and Wolter J. Fabrycky, *Systems Engineering and Analysis*, 4th ed. (Upper Saddle River, NJ: Pearson Education, 2006), 710.

¹⁸² Benjamin S. Blanchard and Wolter J. Fabrycky, *Systems Engineering and Analysis*, 4th ed. (Upper Saddle River, NJ: Pearson Education, 2006), 710.

¹⁸³ Benjamin S. Blanchard and Wolter J. Fabrycky, *Systems Engineering and Analysis*, 4th ed. (Upper Saddle River, NJ: Pearson Education, 2006), 711.

¹⁸⁴ Benjamin S. Blanchard and Wolter J. Fabrycky, *Systems Engineering and Analysis*, 4th ed. (Upper Saddle River, NJ: Pearson Education, 2006), 711.

¹⁸⁵ Naval Expeditionary Combat Command, *U. S. Navy Riverine Group, Concept of Operations*, 28 September 2006 (Little Creek, VA: GPO, 2006), 1-2.

¹⁸⁶ Naval Expeditionary Combat Command, *U. S. Navy Riverine Group, Concept of Operations*, 28 September 2006 (Little Creek, VA: GPO, 2006), 6.

¹⁸⁷ Naval Expeditionary Combat Command, *U. S. Navy Riverine Group, Concept of Operations*, 28 September 2006 (Little Creek, VA: GPO, 2006), 10-11.

¹⁸⁸ Naval Expeditionary Combat Command, *U. S. Navy Riverine Group, Concept of Operations*, 28 September 2006 (Little Creek, VA: GPO, 2006), 12.

¹⁸⁹ CWO3 Rod Smith, *Riverine One Command Brief*, (18th Navy Counselor Symposium, July 12, 2006), slides.

¹⁹⁰ Naval Expeditionary Combat Command, *U. S. Navy Riverine Group, Concept of Operations*, 28 September 2006 (Little Creek, VA: GPO, 2006), 29.

¹⁹¹ Naval Expeditionary Combat Command, *U. S. Navy Riverine Group, Concept of Operations*, 28 September 2006 (Little Creek, VA: GPO, 2006), 29.

¹⁹² CWO3 Rod Smith, *Riverine One Command Brief*, (18th Navy Counselor Symposium, July 12, 2006), slides.

¹⁹³ CWO3 Rod Smith, *Riverine One Command Brief*, (18th Navy Counselor Symposium, July 12, 2006), slides.

¹⁹⁴ Naval Expeditionary Combat Command, *U. S. Navy Riverine Group, Concept of Operations*, 28 September 2006 (Little Creek, VA: GPO, 2006), 32.

¹⁹⁵ Naval Expeditionary Combat Command, *U. S. Navy Riverine Group, Concept of Operations*, 28 September 2006 (Little Creek, VA: GPO, 2006), 32.

¹⁹⁶ Naval Expeditionary Combat Command, *U. S. Navy Riverine Group, Concept of Operations*, 28 September 2006 (Little Creek, VA: GPO, 2006), 31.

¹⁹⁷ General Jim McCarthy, *Transformation Study Press Briefing*, (Press Briefing, 12 June 2001), slides.

¹⁹⁸ General Jim McCarthy, *Transformation Study Press Briefing*, (Press Briefing, 12 June 2001), slides.

¹⁹⁹ General Jim McCarthy, *Transformation Study Press Briefing*, (Press Briefing, 12 June 2001), slides.

²⁰⁰ General Jim McCarthy, *Transformation Study Press Briefing*, (Press Briefing, 12 June 2001), slides.

²⁰¹ Naval Expeditionary Combat Command, *U. S. Navy Riverine Group, Concept of Operations*, 28 September 2006 (Little Creek, VA: GPO, 2006), 42.

²⁰² Captain David Balk, in discussion with the authors, 29 March 2007.

²⁰³ U.S. Department of the Navy, *Table of Allowances for Riverine Squadron One*, (Washington, DC: GPO, [2007?]).

²⁰⁴ U.S. Department of the Navy, *Table of Allowances for Riverine Squadron One*, (Washington, DC: GPO, [2007?]).

²⁰⁵ U.S. Department of the Navy, *Table of Allowances for Riverine Squadron One*, (Washington, DC: GPO, [2007?]).

²⁰⁶ *Tactical Water Purification System (TWPS)* (Knoxville, TN: Water Technologies, aqua-chem, Inc., [2004?]).

²⁰⁷ U.S. Department of the Navy, *Table of Allowances for Riverine Squadron One*, (Washington, DC: GPO, [2007?]).

²⁰⁸ Naval Expeditionary Combat Command, *U. S. Navy Riverine Group, Concept of Operations*, 28 September 2006 (Little Creek, VA: GPO, 2006), 45.

²⁰⁹ CDR Mike Doran, PCO LCS-1 Gold, *Littoral Combat Ship*, (2007), presentation slides.

²¹⁰ Lockheed Martin, “Our Solution,” *Littoral Combat Ship*, <http://www.lmlcsteam.com/solution.html>.

²¹¹ Lockheed Martin, “Our Solution,” *Littoral Combat Ship*, <http://www.lmlcsteam.com/solution.html>.

²¹² Global Security, “General Dynamics Littoral Combat Ship,” *Global Security.org*, <http://www.globalsecurity.org/military/systems/ship/lcs-pics-gd.htm>.

²¹³ General Dynamics, “Operational Capabilities,” *Littoral Combat Ship*, http://www.gdlcs.com/gd_opsCapability.html.

²¹⁴ Navy.mil, “High-Speed Vessel – HSV,” *United States Navy Fact File*, http://www.navy.mil/navydata/fact_display.asp?cid=4200&tid=1400&ct=4.

²¹⁵ Global Security, “High Speed Vessel,” *Global Security.org*, <http://www.globalsecurity.org/military/systems/ship/hsv-gallery.htm>.

²¹⁶ Navy.mil, “High-Speed Vessel – HSV,” *United States Navy Fact File*, http://www.navy.mil/navydata/fact_display.asp?cid=4200&tid=1400&ct=4.

²¹⁷ Naval-Technology.com, “Frank S. Besson Class LSV Logistic Support Vessel, USA,” *Naval-Technology.com*, <http://www.naval-technology.com/projects/lsv/>.

²¹⁸ Naval-Technology.com, “Frank S. Besson Class LSV Logistic Support Vessel, USA,” *Naval-Technology.com*, <http://www.naval-technology.com/projects/lsv/>.

²¹⁹ Naval-Technology.com, “Frank S. Besson Class LSV Logistic Support Vessel, USA,” *Naval-Technology.com*, <http://www.naval-technology.com/projects/lsv/>.

²²⁰ Clint Lawler, Greg Mitchell, and Il Suh, “Riverine Combat Support Ship (RCSS),” (Report, Massachusetts Institute of Technology, MA, 2006), 16-19.

²²¹ Clint Lawler, Greg Mitchell, and Il Suh, “Riverine Combat Support Ship (RCSS),” (Report, Massachusetts Institute of Technology, MA, 2006), 16-19

²²² Clint Lawler, Greg Mitchell, and Il Suh, “Riverine Combat Support Ship (RCSS),” (Report, Massachusetts Institute of Technology, MA, 2006), 16-19.

²²³ Mobile Riverine Force Association, “Riverine Assault Force,” *Mobile Riverine Force Association*, http://www.mrfa.org/riverine_assault.htm.

²²⁴ Gary P. Priolo, “APL-39/APB-39/IX-502 Mercer,” *NavSource Online*, <http://www.navsource.org/archives/10/13/1339.htm>.

²²⁵ Cotecmar, “Riverine Support Patrol Vessel,” *Cotecmar*, <http://www.cotecmar.com>.

²²⁶ Elmer L. Roman, “Trip Report for the Office of Naval Research Global – Latin America Office visit to the Columbian Navy R&D Institutions, 28-30 June 2006,” (report presentation, Washington, DC, 28-30 June 2006).

²²⁷ Singapore Technologies Engineering, “141m Landing Ship Tank,” *Singapore Technologies Engineering*, <http://www.stengg.com/CoyCapPro/detail.aspx?cylid=&pdid=104>.

²²⁸ Singapore Technologies Engineering, “141m Landing Ship Tank,” *Singapore Technologies Engineering*, <http://www.stengg.com/CoyCapPro/detail.aspx?cylid=&pdid=104>.

²²⁹ Singapore Technologies Engineering, “141m Landing Ship Tank,” *Singapore Technologies Engineering*, <http://www.stengg.com/CoyCapPro/detail.aspx?cyid=&pdid=104>.

²³⁰ Gary P. Priolo, “LST-839 Iredell County,” *NavSource Online*, <http://www.navsource.org/archives/10/16/160839.htm>.

²³¹ Gary P. Priolo, “LST-839 Iredell County,” *NavSource Online*, <http://www.navsource.org/archives/10/16/160839.htm>.

²³² Gary P. Priolo, “LST-1192 Spartanburg County,” *NavSource Online*, <http://www.navsource.org/archives/10/16/161192.htm>.

²³³ Gary P. Priolo, “LST-1192 Spartanburg County,” *NavSource Online*, <http://www.navsource.org/archives/10/16/161192.htm>.

²³⁴ Lockheed Martin, “Our Solution,” *Littoral Combat Ship*, <http://www.lmlcsteam.com/solution.html>.

²³⁵ General Dynamics, “Operational Capabilities,” *Littoral Combat Ship*, http://www.gdlcs.com/gd_opsCapability.html.

²³⁶ Gary P. Priolo, “LST-839 Iredell County,” *NavSource Online*, <http://www.navsource.org/archives/10/16/160839.htm>.

²³⁷ Naval-Technology.com, “Frank S. Besson Class LSV Logistic Support Vessel, USA,” *Naval-Technology.com*, <http://www.naval-technology.com/projects/lsv/>.

²³⁸ Global Security, “High Speed Vessel,” *Global Security.org*, <http://www.globalsecurity.org/military/systems/ship/hsv-gallery.htm>.

²³⁹ Evin Thompson, CAPT USSOCOM NSWG4, e-mail message to the author, March 12, 2007.

²⁴⁰ Clint Lawler, Greg Mitchell, and Il Suh, “Riverine Combat Support Ship (RCSS),” (Report, Massachusetts Institute of Technology, MA, 2006), 3.

²⁴¹ Singapore Technologies Engineering, “141m Landing Ship Tank,” *Singapore Technologies Engineering*, <http://www.stengg.com/CoyCapPro/detail.aspx?cyid=&pdid=104>.

²⁴² Gary P. Priolo, “LST-1192 Spartanburg County,” *NavSource Online*, <http://www.navsource.org/archives/10/16/161192.htm>.

²⁴³ Cotecmar, “Riverine Support Patrol Vessel,” *Cotecmar*, <http://www.cotecmar.com>.

²⁴⁴ Navy.mil, “High-Speed Vessel – HSV,” *United States Navy Fact File*, http://www.navy.mil/navydata/fact_display.asp?cid=4200&tid=1400&ct=4.

²⁴⁵ Gary P. Priolo. “APL-39/APB-39/IX-502 Mercer,” *NavSource Online*, <http://www.navsource.org/archives/10/13/1339.htm>.

²⁴⁶ Gary P. Priolo, “Tank Landing Ship (LST) Index,” *NavSource Online*, <http://www.navsource.org/archives/10/16/16idx.htm>.

²⁴⁷ Naval Expeditionary Combat Command, *U. S. Navy Riverine Group, Concept of Operations*, 28 September 2006 (Little Creek, VA: GPO, 2006), 42.

²⁴⁸ Naval Expeditionary Combat Command, *U. S. Navy Riverine Group, Concept of Operations*, 28 September 2006 (Little Creek, VA: GPO, 2006), 42.

²⁴⁹ “Concept Paper on Global Fleet Stations” (working paper, U.S. Department of Navy, 25 January 2007).

²⁵⁰ “Concept Paper on Global Fleet Stations” (working paper, U.S. Department of Navy, 25 January 2007).

²⁵¹ “Concept Paper on Global Fleet Stations” (working paper, U.S. Department of Navy, 25 January 2007).

²⁵² Federation of American Scientists, “LHD-1 Wasp Class,” *Federation of American Scientists*, <http://www.fas.org/man/dod-101/sys/ship/lhd-1.htm>.

²⁵³ “Concept Paper on Global Fleet Stations” (working paper, U.S. Department of Navy, 25 January 2007).

²⁵⁴ Center for Naval Analyses, *Renewal of Navy’s Riverine Capability: Resource Implications for Combat Support/Combat Service Support and TSC*, January 2006 (Alexandria, VA: GPO, 2006), 31.

²⁵⁵ “Concept Paper on Global Fleet Stations” (working paper, U.S. Department of Navy, 25 January 2007).

²⁵⁶ Naval Expeditionary Combat Command, *U.S. Navy Riverine Group, Concept of Operations*, 28 September 2006 (Little Creek, VA: GPO, 2006), 17.

²⁵⁷ U.S. Department of the Navy, *Marine Corp Reference Publication (MCRP) 4-11.8A: Food Services Reference*, 10 September 1999 (Washington, DC: GPO, 1999) 12.

²⁵⁸ U.S. Department of the Navy, *Marine Corp Reference Publication (MCRP) 4-11.8A: Food Services Reference*, 10 September 1999 (Washington, DC: GPO, 1999) 5.

²⁵⁹ Defense Logistics Agency, “Operational Rations,” *Subsistence Homepage*, <http://www.dscpl.dla.mil/subs/rations/programs/index.asp>.

²⁶⁰ Defense Logistics Agency, “Operational Rations,” *Subsistence Homepage*, <http://www.dscpl.dla.mil/subs/rations/programs/index.asp>.

²⁶¹ Defense Logistics Agency, “Operational Rations,” *Subsistence Homepage*, <http://www.dscpl.dla.mil/subs/rations/programs/index.asp>.

²⁶² Defense Logistics Agency, “Operational Rations,” *Subsistence Homepage*, <http://www.dscpl.dla.mil/subs/rations/programs/index.asp>.

²⁶³ Defense Logistics Agency, “Operational Rations,” *Subsistence Homepage*, <http://www.dscpl.dla.mil/subs/rations/programs/index.asp>.

²⁶⁴ CDR David Schiffman, *OS4580 Logistics; Sustainability*, (Naval Postgraduate School, 01 April 2007), slides.

²⁶⁵ Defense Logistics Agency, “Operational Rations,” *Subsistence Homepage*, <http://www.dscpl.dla.mil/subs/rations/programs/index.asp>.

²⁶⁶ Evin Thompson, CAPT USSOCOM NSWG4, email message to the author, March 12, 2007.

²⁶⁷ Clint Lawler, Greg Mitchell, and Il Suh, “Riverine Combat Support Ship (RCSS),” (Report, Massachusetts Institute of Technology, MA, 2006), Appendix K.

²⁶⁸ U.S. Department of the Navy, *Marine Corp Reference Publication (MCRP) 4-11A, Vol 1: Combat Service Support Field Reference Guide*, 12 June 2000 (Washington, DC: GPO, 2000) 10.

²⁶⁹ Michael Corpening, Linda Hurry, and Gregory Young, “The Role of Seabasing in SOF Operations,” (Report, Joint Forces Staff College, RI, 2006), 8.

²⁷⁰ U.S. Department of the Navy, *Marine Corp Reference Publication (MCRP) 4-11A, Vol 1: Combat Service Support Field Reference Guide*, 12 June 2000 (Washington, DC: GPO, 2000) 15.

²⁷¹ U.S. Department of the Navy, *Marine Corps Reference Publication 3-31B: Amphibious Ships and Landing Craft Data Book*, 29 August 2001 (Washington, DC: GPO, 2001), 24.

²⁷² U.S. Department of the Navy, *Marine Corps Reference Publication 3-31B: Amphibious Ships and Landing Craft Data Book*, 29 August 2001 (Washington, DC: GPO, 2001), 24.

²⁷³ Federation of American Scientists, “Landing Craft Air Cushion (LCAC),” *Federation of American Scientists*, <http://www.fas.org/man/dod-101/sys/ship/lcac.htm>.

²⁷⁴ U.S. Department of the Navy, *Marine Corps Reference Publication 3-31B: Amphibious Ships and Landing Craft Data Book*, 29 August 2001 (Washington, DC: GPO, 2001), 24.

²⁷⁵ U.S. Department of the Navy, *Marine Corps Reference Publication 3-31B: Amphibious Ships and Landing Craft Data Book*, 29 August 2001 (Washington, DC: GPO, 2001), 25.

²⁷⁶ Global Security, “Landing Craft Utility (LCU),” *Global Security.org*, <http://www.globalsecurity.org/military/systems/ship/lcu-gallery.htm>.

²⁷⁷ U.S. Department of the Navy, *Marine Corps Reference Publication 3-31B: Amphibious Ships and Landing Craft Data Book*, 29 August 2001 (Washington, DC: GPO, 2001), 25.

²⁷⁸ U.S. Department of the Navy, *Marine Corps Reference Publication 3-31B: Amphibious Ships and Landing Craft Data Book*, 29 August 2001 (Washington, DC: GPO, 2001), 26.

²⁷⁹ Global Security, “Mechanized Landing Craft (LCM),” *Global Security.org*, <http://www.globalsecurity.org/military/systems/ship/lcm-gallery.htm>.

²⁸⁰ U.S. Department of the Navy, *Marine Corps Reference Publication 3-31B: Amphibious Ships and Landing Craft Data Book*, 29 August 2001 (Washington, DC: GPO, 2001), 26.

²⁸¹ Norman Polmar, *The Naval Institute Guide to the Ships and Aircraft of the U.S. Fleet*, 18th ed. (Annapolis, MD: Naval Institute Press, 2005), 629.

²⁸² Global Security, “Landing Craft Utility (LCU),” *Global Security*, <http://www.globalsecurity.org/military/systems/ship/lcu-gallery.htm>.

²⁸³ Norman Polmar, *The Naval Institute Guide to the Ships and Aircraft of the U.S. Fleet*, 18th ed. (Annapolis, MD: Naval Institute Press, 2005), 629.

²⁸⁴ SEACOR Marine, “Jim G,” *SEACOR Marine*, <http://www.seacormarine.com/ourfleet.cgi?type=ms>.

²⁸⁵ SEACOR Marine, “Jim G,” *SEACOR Marine*, <http://www.seacormarine.com/ourfleet.cgi?type=ms>.

²⁸⁶ SEACOR Marine, “Jim G,” *SEACOR Marine*, <http://www.seacormarine.com/ourfleet.cgi?type=ms>.

²⁸⁷ SEACOR Marine, “Sharon F,” *SEACOR Marine*, <http://www.seacormarine.com/ourfleet.cgi?type=crewfsv>.

²⁸⁸ SEACOR Marine, “Sharon F,” *SEACOR Marine*, <http://www.seacormarine.com/ourfleet.cgi?type=crewfsv>.

²⁸⁹ Federation of American Scientists, “SH-60 LAMPS MK III Seahawk,” *Federation of American Scientists*, <http://www.fas.org/man/dod-101/sys/ac/sh-60.htm>.

²⁹⁰ Federation of American Scientists, “SH-60 LAMPS MK III Seahawk,” *Federation of American Scientists*, <http://www.fas.org/man/dod-101/sys/ac/sh-60.htm>.

²⁹¹ Norman Polmar, *The Naval Institute Guide to the Ships and Aircraft of the U.S. Fleet*, 18th ed. (Annapolis, MD: Naval Institute Press, 2005), 457.

²⁹² Federation of American Scientists, “CH-53E Sea Stallion,” *Federation of American Scientists*, <http://www.fas.org/man/dod-101/sys/ac/h-53.htm>.

²⁹³ Norman Polmar, *The Naval Institute Guide to the Ships and Aircraft of the U.S. Fleet*, 18th ed. (Annapolis, MD: Naval Institute Press, 2005), 457.

²⁹⁴ Norman Polmar, *The Naval Institute Guide to the Ships and Aircraft of the U.S. Fleet*, 18th ed. (Annapolis, MD: Naval Institute Press, 2005), 446.

²⁹⁵ Federation of American Scientists, “V-22 Osprey,” *Federation of American Scientists*, <http://www.fas.org/man/dod-101/sys/ac/v-22.htm>.

²⁹⁶ Norman Polmar, *The Naval Institute Guide to the Ships and Aircraft of the U.S. Fleet*, 18th ed. (Annapolis, MD: Naval Institute Press, 2005), 446.

²⁹⁷ U.S. Department of the Navy, *NATOPS Flight Manual Navy Model MV-22B Tiltrotor*, 1 June 2000 (Washington, DC: GPO, 2000), I-1-11.

²⁹⁸ U.S. Department of the Navy, *NATOPS Flight Manual Navy Model MV-22B Tiltrotor*, 1 June 2000 (Washington, DC: GPO, 2000), I-4-8.

²⁹⁹ Captain David Balk, in discussion with the authors, 29 March 2007.

³⁰⁰ U.S. Department of the Navy, *Marine Corps Reference Publication 3-31B: Amphibious Ships and Landing Craft Data Book*, 29 August 2001 (Washington, DC: GPO, 2001), 25.

³⁰¹ Norman Polmar, *The Naval Institute Guide to the Ships and Aircraft of the U.S. Fleet*, 18th ed. (Annapolis, MD: Naval Institute Press, 2005), 629.

³⁰² SEACOR Marine, “Jim G,” *SEACOR Marine*, <http://www.seacormarine.com/ourfleet.cgi?type=ms>.

³⁰³ Federation of American Scientists, “SH-60 LAMPS MK III Seahawk,” *Federation of American Scientists*, <http://www.fas.org/man/dod-101/sys/ac/sh-60.htm>.

³⁰⁴ U.S. Department of the Navy, *N87 Resource Officer’s Guide for Conducting Risk Assessment*, 26 January 2007 (Washington, DC: GPO, 2007), 11-12.

³⁰⁵ Andrew P. Sage and James E. Armstrong Jr., *Introduction to Systems Engineering* (New York: John Wiley & Sons, 2000), 155.

³⁰⁶ CAPT David Balk, in discussion with the authors, March 29, 2007.

³⁰⁷ Andrew P. Sage and James E. Armstrong Jr., *Introduction to Systems Engineering* (New York: John Wiley & Sons, 2000), 155.

³⁰⁸ Department of Defense, *Joint Publication 1-02: Department of Defense Dictionary of Military and Associated Terms*, 1 March 2007 (Washington, D.C.: GPO, 12 April 2001), 210.

³⁰⁹ CMC (SCW) Robert Grenier, “CM Manning Point Paper” (working paper, U.S. Department of the Navy, 3 April 2007).

³¹⁰ “SURC Failure Reporting Analysis and Corrective Action System (FRACAS) Information,” *Raytheon Technical Services, Customer Logistics Support (CLS) Quarterly Report*, (March 26 2007).

³¹¹ CMC (SCW) Robert Grenier, “CM Manning Point Paper” (working paper, U.S. Department of the Navy, 3 April 2007).

³¹² Raytheon Integrated Defense Systems, *Small Unit Riverine Craft (SURC) Reliability Summary 06-Q2*, Quarterly Report, August 2006.

³¹³ LCDR Frank Okata, “Riverine Support Unit” (working paper, U.S. Department of the Navy, 3 April 2007).

³¹⁴ “Navy Times Editorial: Clarity on Force Cuts,” *Navy Times*, http://www.navytimes.com/community/opinion/navy_opinion_editorial070219/ (accessed : April 2007).

³¹⁵ Breanne Wagner, “Brown-Water Navy begins hunt for new riverine combat craft,” *National Defense*, <http://www.nationaldefensemagazine.org/issues/2007/April/BrownWaterNavy.htm>.

³¹⁶ “SURC Failure Reporting Analysis and Corrective Action System (FRACAS) Information,” *Raytheon Technical Services, Customer Logistics Support (CLS) Quarterly Report*, (March 26 2007).

³¹⁷ Professor Langford, interview with the authors, April 25, 2007.

³¹⁸ Sensor Fence, “Technology,” *SensorFence*, <http://www.sensorfence.com/invention.html>.

³¹⁹ FLIR Systems, “ThermoVision Sentry II,” *FLIR Systems*, <http://www.flir.com/imaging/Security/Products/ThermoVisionSentryII.aspx>.

³²⁰ FLIR Systems, “ThermoVision Sentry II,” *FLIR Systems*, <http://www.flir.com/imaging/Security/Products/ThermoVisionSentryII.aspx>.

³²¹ FLIR Systems, “SeaFLIR III,” *FLIR Systems*, <http://www.flir.com/imaging/Maritime/Products/SeaFLIRIII.aspx>.

³²² Clay Wild, Director Maritime Systems, FLIR Systems, Inc. interview with the authors, May 9, 2007.

³²³ FLIR Systems, “SeaFLIR III,” *FLIR Systems*, <http://www.flir.com/imaging/Maritime/Products/SeaFLIRIII.aspx>.

³²⁴ Navy Opportunity Forum, “Advanced Laser Target Designator/ Target Designator for the Mk 46 Optical Sight System (Mk 46 OSS),” *Navy Opportunity Forum*, <http://www.navyopportunityforum.com/abstracts.php?viewPageNum=3&query=&casesensitive=&matchword=>.

³²⁵ Naval-Technology, “Kollmorgen Electro-Optical Awarded \$13.75M Contract for MK46 Optical Sight Systems,” *Naval-technology.com*, http://www.naval-technology.com/contractors/weapon_control/kollmorgen/press4.html.

³²⁶ Kollmorgen Electro-Optical, “Mk 46 Mod 1 Optical Sight System,” *Kollmorgen Electro-Optical*, http://www.eo.kollmorgen.com/uploads/textWidget/wysiwyg/documents/AD-39_MK46_datasht.pdf.

³²⁷ Federation of American Scientists, “AN/SPS-67,” *Federation of American Scientists*, <http://www.fas.org/man/dod-101/sys/ship/weaps/an-sps-67.htm>.

³²⁸ Jane’s Radar and Electronic Warfare Systems, “AN/SPS-67(V) search radar,” *Jane’s Information Group*, http://www8.janes.com/Search/documentView.do?docId=/content1/janesdata/yb/jrew/jrew0382.htm@current&pageSelected=allJanes&keyword=SPS-67&backPath=http://search.janes.com/Search&Prod_Name=JREW&.

³²⁹ Raytheon Corporation, “AN/SPS-67,” *Raytheon Corporation*, <http://www.raytheon.com/newsroom/photogal/photos/sps67.jpg>.

³³⁰ dtic, “Army RDT&E Budget Item Justification (R2a Exhibit),” *dtic.mil*, <http://www.dtic.mil/descriptivesum/Y2008/Army/0604823A.pdf>.

³³¹ Rupert Pengelly, “Military assess the long and short of weapon location,” *Jane’s International Defense Review*, 1 September 2004.

³³² Joshua Kucera, “Army calls for improved counter-mortar radar,” *Jane’s Defense Weekly*, 9 February 2006.

³³³ Scott R. Gourley, “Lightweight Counter-Mortar Radar,” *Army Magazine*, April 2002.

³³⁴ Global Security, “M120 120 mm Mortar,” *Global Security.org*, <http://www.globalsecurity.org/military/systems/ground/m120.htm>.

³³⁵ Global Security, “M120 120 mm Mortar,” *Global Security.org*, <http://www.globalsecurity.org/military/systems/ground/m120.htm>.

³³⁶ Armed Forces International, “PGMM – It’s a hit!” *Armed Forces International*, <http://www.armedforces-int.com/categories/guided-mortar-munitions/pgmm-hit.asp>.

³³⁷ Armed Forces International, “PGMM – It’s a hit!” *Armed Forces International*, <http://www.armedforces-int.com/categories/guided-mortar-munitions/pgmm-hit.asp>.

³³⁸ Federation of American Scientists, “U.S. Land Warfare Systems,” *Federation of American Scientists*, <http://www.fas.org/man/dod-101/sys/land/index.html>.

³³⁹ Federation of American Scientists, “U.S. Navy Shipboard Combat Systems,” *Federation of American Scientists*, <http://www.fas.org/man/dod-101/sys/ship/weaps/index.html>.

³⁴⁰ Cochran Steel, “Typical Razor Wire Fence Applications,” *Cochran Steel*, <http://www.cochransteel.com/typical.html>.

³⁴¹ U.S. Department of the Army, *Field Manual(FM) 5-114: Engineering Operations Short of War* (Washington, DC: GPO, 1992), Appendix A.

³⁴² Wave Dispersion Technologies, “Maritime Homeland Defense and Force Protection Port Security Solutions: WhisprWave,” *Wave Dispersion Technologies*, <http://www.whisprwave.com/port.htm#scib>.

³⁴³ Marty Kauchak, “Building Forts,” *Special Operations Technology*, November 19, 2006, <http://www.special-operations-technology.com/article.cfm?DocID=1797>.

³⁴⁴ Geocell Systems, “Rapid Deployment Fortification Wall (RDFW),” *Geocell Systems*, http://www.geocell-systems.com/brochures/pdfs/Modular_Versatile.pdf.

³⁴⁵ Geocell Systems, “Rapid Deployment Fortification Wall (RDFW),” *Geocell Systems*, http://www.geocell-systems.com/brochures/pdfs/Modular_Versatile.pdf.

³⁴⁶ Federation of American Scientists, “Special Operation Forces Reference Manual (Version 2.1 Academic Year 99/00, Army Command and General Staff College,” *Federation of American Scientists*, http://www.fas.org/irp/agency/dod/socom/sof-ref-2-1/SOFREF_Ch4.htm.

³⁴⁷ Naval-Technology.com, “Vigilant Port Security Boat,” *Naval-technology.com*, <http://www.naval-technology.com/contractors/patrol/brunswick/brunswick2.html>.

³⁴⁸ Army.mil, “HMMWV,” *U.S. Army Fact File*, http://www.army.mil/fact_files_site/hmmwv/index.html.

³⁴⁹ James W. Beaver and others, “Systems Analysis of Alternative Architectures for Riverine Warfare in 2010” (MS diss., Naval Postgraduate School, 2006), 104.

³⁵⁰ James W. Beaver and others, “Systems Analysis of Alternative Architectures for Riverine Warfare in 2010” (MS diss., Naval Postgraduate School, 2006), 104.

³⁵¹ Military.com, “A PAIR OF FOXES: The Navy's New RPV Lineup,” *Military.com*, http://www.military.com/soldiertech/0,14632,Soldiertech_SeaFox,,00.html.

³⁵² Military.com, “A PAIR OF FOXES: The Navy's New RPV Lineup,” *Military.com*, http://www.military.com/soldiertech/0,14632,Soldiertech_SeaFox,,00.html.

³⁵³ Military.com, “A PAIR OF FOXES: The Navy's New RPV Lineup,” *Military.com*, http://www.military.com/soldiertech/0,14632,Soldiertech_SeaFox,,00.html.

³⁵⁴ Military.com, “A PAIR OF FOXES: The Navy's New RPV Lineup,” *Military.com*, http://www.military.com/soldiertech/0,14632,Soldiertech_SeaFox,,00.html.

³⁵⁵ Military.com, “A PAIR OF FOXES: The Navy's New RPV Lineup,” *Military.com*, http://www.military.com/soldiertech/0,14632,Soldiertech_SeaFox,,00.html.

³⁵⁶ General Dynamics, “U.S. Navy Type Classifies Mk49 MOD 0 Gun Weapon System,” *General Dynamics*, <http://www.gdatp.com/news/2005/NR-019.htm>.

³⁵⁷ General Dynamics, “U.S. Navy Type Classifies Mk49 MOD 0 Gun Weapon System,” *General Dynamics*, <http://www.gdatp.com/news/2005/NR-019.htm>.

³⁵⁸ Ben Hardie, *Mini-Typhoon Remote Operated Small Arms Mount*, (General Dynamics: Armament and Technical Products, April 27, 2005), slides.

³⁵⁹ Vic Ricci, *Spartan Scout ACTD USV Overview and Status*, (Naval Undersea Warfare Center, March 10, 2006), slides.

³⁶⁰ U.S. Department of the Navy, *N87 Resource Officer's Guide for Conducting Risk Assessment*, 26 January 2007 (Washington, DC: GPO, 2007).

THIS PAGE INTENTIONALLY LEFT BLANK

5. MODELING OVERVIEW

5.1 MODELING PURPOSE AND COMPONENTS

The operational architecture combines the physical and functional architectures so as to meet the originating requirements and related derived requirements. This combination of the physical and functional architectures requires the allocation of functions to physical resources; at this point the system's design can be simulated and analyzed in terms of the originating requirements and operational concept of the stakeholders. As the physical and functional architectures are integrated, the interfaces of the system (both external and internal) can also be defined and designed.³⁶¹

The RST used this process to define and develop the riverine sustainment problem for further modeling and analysis.

Initially, the design process establishes functional and physical decompositions, which are united to form the operational architecture. The operational architecture divides the design problem into chunks, primarily along the lines of the physical architecture. The operational architecture provides a complete description of the system design, including the functional architecture allocated to the physical architecture, derived input/output, technology and system-wide, trade off, and qualification requirements for each component, an interface architecture that has been integrated as one of the components, and complete documentation of the design and major design decisions.³⁶²

The RST started with the RF's operational concept and utilized a combination of the physical and functional architectures to develop the operation architecture. Modeling and simulation enabled the RST to measure physical architecture alternatives that achieved RF sustainment functional objectives. The RST used Extend, SIMKIT, and MANA (Map Aware Non-uniform Automata) simulation programs to test the performance and effectiveness of the various alternatives. This section discusses what software used, model setup, and data outputs that the RST employed in the Riverine Sustainment 2012 Study.

5.2 SUPPLY GROUP

There were several objectives for the RST in the operation of transferring supply between the supply ship and the operating base for the riverine forces. One objective was to assess the optimal number and combination of supply crafts required to support different kinds of operating base. Another objective was to assess the effect of the supply ship turn around time. To address those objectives of this study, a simulator was developed based on the event graph paradigm^{363 364 365} and the Listener Event Graph Objects (LEGOS) framework.^{366 367} Another simulator was developed using Extend that further evaluates the “best” connectors and measures operational availability and operational habitability.

5.2.1 SIMKIT Software

The riverine logistic supply process was modeled using the event graph paradigm, and the simulator was built based on SIMKIT and the LEGOS framework. The discrete event simulation (DES) movement model can be found in Buss & Sanchez.³⁶⁸ The simulator was designed to derive the performance variables based on different mix of supply helicopters and different types of sea supply crafts. The motivation to use DES in modeling RF logistic operations was due to the dynamic and stochastic nature of such operations. Analytic and algorithmic models are not applicable due to the lack of consistent formulae to model the dynamic composition. Similarly, despite the fact that there are existing logistic management systems that can effectively ensure the continuous support of the RF, such systems require long periods of operation time within a defined AO before it stabilizes at optimum level. The locations of the AO tend to be “fluid” and the duration considerably short term (180 days) compared to other campaigns. As such, DES became the ideal approach to model such operations, “averaging” out the dynamic and stochastic elements, to provide the basis which the RST would recommend for Riverine logistic support strategy to be based upon. The simulation was event driven rather than time step dependent (such as agent based models are). This was due to the

fact that discrete event modeling reduces the simulation time, especially when the logistic support can be easily considered as events.

5.2.2 SIMKIT Set-up

Multiple simulation runs have been performed by adjusting mainly three set of the parameters: operating base parameters; mix of supply crafts; and position of the operation base. The parameters for the FOB, Norbriza+Barge (MOB1), and RCSS/Endurance/Sri Inderapura (MOB2) are given in Table 28. The supply connectors' parameters are given in Table 29. The supply connector mix for the operating bases are given in Table 30. The supply ship cycle time has also been varied from 4 days to 9 days in discrete increments.

Base	Capacity (ton)	Threshold (ton)	Storage (days)
FOB	495	67	15
MOB1	529	73	15
MOB2	818	110	15

Table 28. Operating Base Parameters

Supply Craft	Unit	LCU-1610	Jim G	LCU-2000	CH-53
Speed	kts	6 ± 2	9 ± 2	6 ± 2	100 ± 10
Weight	tons	106	330	260	10
Loading time	ton/min	2	1	2	2
Unloading time	ton/min	4	2	4	2

Table 29. Supply Craft Parameters

The RST limited the total number of vessels to two in order to minimize the number of assets in the AO.

Combination for FOB and MOB1				Combination for MOB2			
LCU-1610	Jim G	LCU-2000	CH-53	LCU-1610	Jim G	LCU-2000	CH-53
0	0	0	1	0	0	0	1
0	0	0	2	0	0	0	2
0	0	1	0	0	1	0	0
0	0	1	1	0	1	0	1
0	0	1	2	0	1	0	2
0	0	2	0	0	2	0	0
0	0	2	1	0	2	0	1
0	0	2	2	0	2	0	2
0	1	0	0	1	0	0	0
0	1	0	1	1	0	0	1
0	1	0	2	1	0	0	2
0	1	1	0	1	1	0	0
0	1	1	1	1	1	0	1
0	1	1	2	1	1	0	2
0	2	0	0	2	0	0	0
0	2	0	1	2	0	0	1
0	2	0	2	2	0	0	2
1	0	0	0				
1	0	0	1				
1	0	0	2				
1	0	1	0				
1	0	1	1				
1	0	1	2				
1	1	0	0				
1	1	0	1				
1	1	0	2				
2	0	0	0				
2	0	0	1				
2	0	0	2				

Table 30. Supply Connector Mix

The model was capable of simulating weather conditions and the affect on performance due to speed and capacity reduction. In particular, the RST simulated four types of weather conditions: clear weather, wind at 20-40 knots, sea state at 3-5, and visibility less than 500 yards. The supply crafts have the same speed and capacity reduction factors for the different types of weather conditions. The speed and capacity reduction factor when the wind was 20-40 knots was 0.2. The speed and capacity reduction factor when the sea state was at 3-5 was 0.5. The speed reduction factor when visibility was less than 500 yards was 0.9, and there was no capacity reduction factor.

5.2.3 SIMKIT Data Outputs

The metrics were organized into 3 parts: supply ship, operating base and supply craft as described below:

5.2.3.1 Metrics for Supply Ship

Queue Length: This is the mean number of supply connectors waiting in the queue for loading of supply. There is a possibility that the number of supply connectors exceed the number of loading operation capacity such as wharf, dock or crane, or personnel. Under such circumstances, the supply connector has to wait outside the supply ship until the resources are available.

Available Loader: This is the mean number resources available to conduct the loading operation, such as wharf, dock or crane, personnel.

Delay In Queue: This is the mean time that each supply connector waits in the queue. This is the time from when the supply connector arrives at the loading bay to the time when the loading operation actually commences.

Loading Time: This is the mean amount of time required to load the supply connector. The loading time is a function of the amount of supply carried onboard, which is either the capacity of the supply connector or the outstanding amount to be delivered, whichever is lower.

Presence Duration: This is the mean amount of time required for the supply ship to be present for the entire supply operation. This is the time from the arrival of the supply ship to the time when the supply demands are loaded onto the supply connector.

Number of global supply ship arrival: This is the number of occurrence when the supply ship arrives at the mouth of the river.

5.2.3.2 Metrics for Operating Base

Unloader Queue: This is the mean number of supply connectors waiting in the queue for unloading the supply. There is a possibility that the number of supply connectors exceed the number of unloading operation capacity such as wharf, dock or crane, personnel. Under such circumstances, the supply connector has to wait outside the operating base until the resources are available.

Available Unloader: This is the mean number of resources available to conduct the unloading operation, such as wharf, dock or crane, personnel.

Delay in Queue: This is the mean time that each supply connector waits in the queue. This is the time from when the supply connector arrives at the operating base to the time when the loading operation actually commences.

Unloading Time: This is the mean amount of time required to unload the supply connector. The unloading time is a function of the amount of supply carried onboard, which is either the capacity of the supply craft or the outstanding amount to be delivered, whichever is lower.

Mean Supply Level: This is the mean supply level at the operating base. The supply level is continuously being depleted based on the consumption rate and will only be incremented after the unloading operation is complete. The mean supply level will be lower if the entire supply chain is slow.

Supply Request level: This is the amount of supply requested each time when the supply ship arrives. This is the difference between the operating base maximum capacity and the current supply level.

Percent Time Supply Below Threshold Level: This is the fraction of time when the supply level dipped below designated threshold level.

Percent Time Supply is Negative: This is the fraction of time when the supply level dipped into negative level

Duration Supply Below Threshold Level: This is the duration of time when the supply level dipped below designated threshold level.

Duration Supply is Negative: This is the duration of time when the supply level dipped into negative level

Number of Occurrences Supply Below Threshold Level: This is the number of occurrences when the supply level dipped below designated threshold level.

Number of Occurrences Supply Below Zero: This is the number of occurrences when the supply level dipped into negative level

Time to Deliver One Batch of Supply: This is the time required for the delivery of the entire batch of supply. This is the time from the arrival of supply ship to the unloading of the entire supply level requested at the operating base.

5.2.3.3 Metrics for Supply Craft

Percent Loading State: This is the fraction of time when the supply connector conducts the loading operation. It includes the time in the loading queue.

Percent Unloading State: This is the fraction of time when the supply connector conducts the unloading operation. It includes the time in the unloading queue.

Percent Ingress: This is the fraction of time when the supply connector travels from the supply ship to the operating base.

Percent Egress: This is the fraction of time when the supply connector travels from operating base to the supply ship.

Traveling Time: This is the mean time for the supply connector to travel from the supply ship to the operating base and back to the supply ship.

5.2.4 SIMKIT Software Processes, Assumptions and Limitations

The modularity approach using listeners and adaptors allowed piecewise building of the simulation, which improved the confidence level of the model while reducing the syntax and semantic errors in coding. By identifying the relevant events relating to the logistic support structure, the DES was quickly designed and built on SIMKIT Java Libraries.

The DES used involved the modeling of several entities that individually encompasses various event states. The models were subsequently coded in SIMKIT in Java Language. The following illustrate the various entities models, represented in event graphs.

5.2.4.1 SeaSupplyCraftCreator Listener Object

The event graph for the SeaSupplyCraftCreator Listener Object is as shown in Figure 94. At the start of the simulation, the run event scheduled the SeaSupplyCraftCreator event, which also recursively scheduled itself until the required quantity of SeaSupplyCraft was created. Upon creating each SeaSupplyCraft, the SeaSupplyCraft was sent to the SeaSupplyCraftDepot by the scheduling of the ArrivalSeaSupplyCraftDepot event.

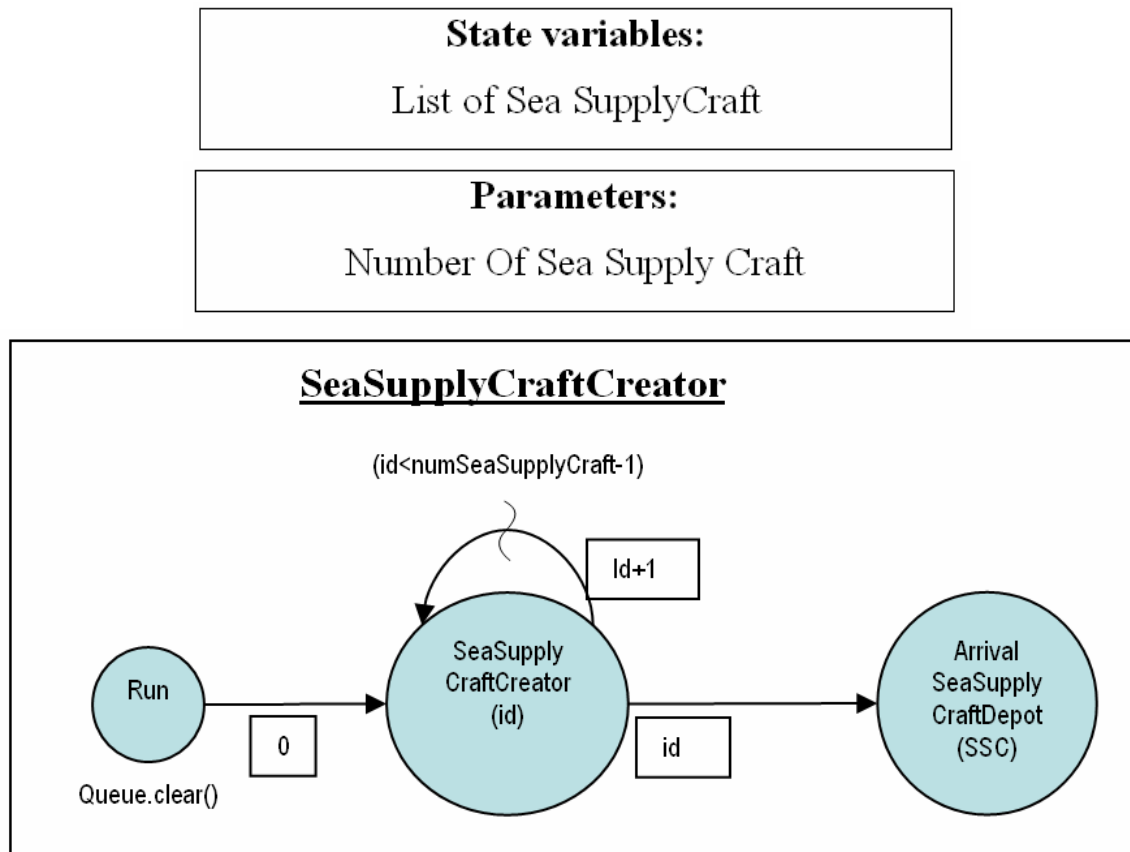

Figure 94. Event Graph for SeaSupplyCraftCreator Object

5.2.4.2 SeaSupplyScheduler Listener Object

The event graph for the SeaSupplyScheduler Listener Object is as shown in Figure 95. At the start of the simulation, the run event simply initialized the state variables and did not schedule any event. An ArrivalSeaSupplyCraftDepot event added the new SeasSupplyCraft into the list. If supply demand was more than supply delivered, it scheduled a DeploySeaSupplyCraftFromDepot event. The FuelRequest event cumulated the demand request and scheduled the DeploySeaSupplyCraftFromDepot event if the demand was not met and that there were available SeaSupplyCraft. The DeploySeaSupplyCraftFromDepot, when scheduled, removed the SeaSupplyCraft from its list and cumulated the supply delivered quantity. It also rescheduled itself if the demand was not met and that there were available SeaSupplyCraft. Note that ArrivalSeaSupplyCraftDepot was the same event in SeaSupplyCraftCreator object and SeaSupplyCraftTravelManager object and FuelRequest event was the same event in the OperatingBase object.

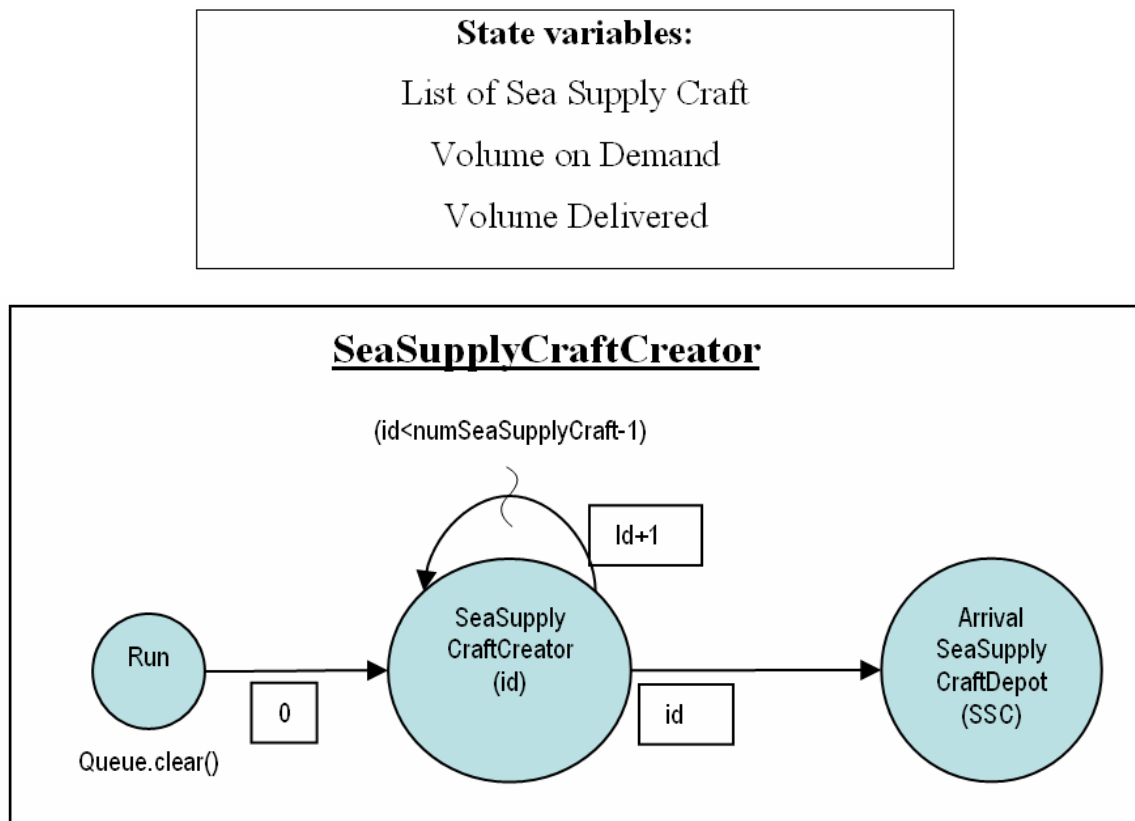

Figure 95. Event Graph for SeaSupplyScheduler Object

5.2.4.3 SeaSupplyCraftDepot Listener Object

The event graph for the SeaSupplyCraftDepot Listener Object is as shown in Figure 96. At the start of the simulation, the run event simply initialized the state variables and did not schedule any event. An ArrivalSeaSupplyCraftDepot event added the new SeasSupplyCraft into the list after stamping the time and updating its states. The DeploySeaSupplyCraftFromDepot event removed the first available SeaSupplyCraft from the list and scheduled the ArrivalGlobalSupplyStation event after recording its time in the depot. Note that ArrivalSeaSupplyCraftDepot was the same event in SeaSupplyCraftCreator object, and DeploySeaSupplyCraftFromDepot was the same event in SeaSupplyScheduler object.

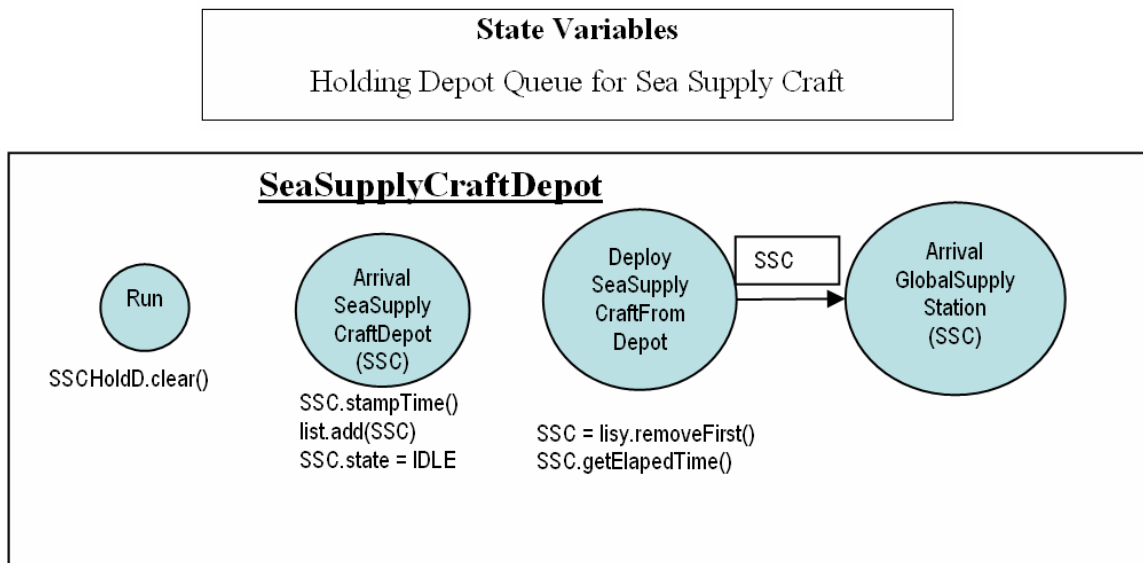

Figure 96. Event Graph for SeaSupplyCraftDepot Object

5.2.4.4 SupplyStation Listener Object

The event graph for the GlobalSupplyStation Listener Object is as shown in Figure 97. At the start of the simulation, the run simply initialized the state variables and did not schedule any event. The ArrivalSupplyStation event updated the state of the SeaSupplyCraft to loadingState and also stamped the time of arrival. The SeaSupplyCraft was placed in the queue. The ArrivalGlobalSupplyStation then scheduled the startLoading event if there were available loader. The StartLoading event removed the

first SeaSupplyCraft in the queue, received the queue delay, decremented the number of available loader, stamped the start loading time and scheduled the EndSeaLoading event to occur after the loading time $T_{loading}$. The EndSeaLoading event updated the loading time and incremented the number of available loader. It also scheduled StartLoading event if there were SeaSupplyCraft in the queue. The end loading event scheduled the SeaSupplyCraftIngress event. Note that ArrivalGlobalSupplyStation is the same event in SeaSupplyCraftDepot.

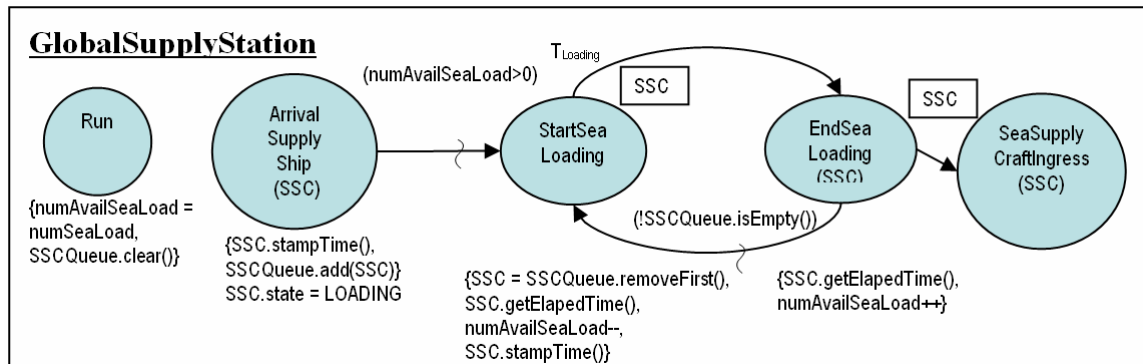
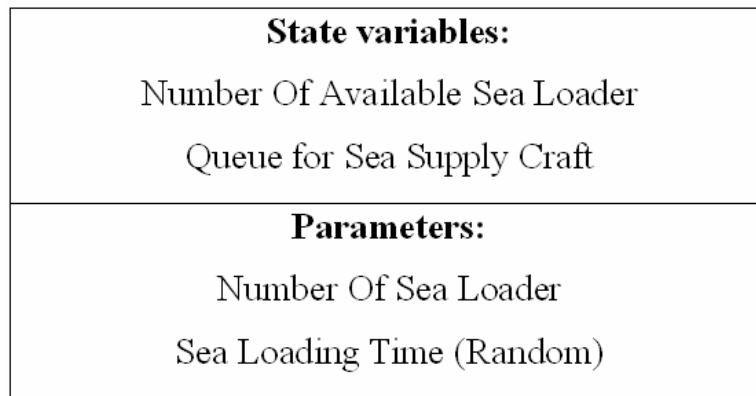

Figure 97. Event Graph for SupplyStation Object

5.2.4.5 Travel Manager Listener Object

The event graph for the TravelManager Listener Object is as shown in Figure 98. At the start of the simulation, the run event simply initialized the state variables and did not schedule any event. The SeaSupplyCraftIngress event stamped time, set the SeaSupplyCraft state, configured the waypoint for the path and scheduled StartMoving event. The StartMoving event scheduled the EndMoving event to be occurred after moving time T_{move} , which in turn scheduled the ArrivalAtOperatingBase

event. Similarly, the SeaSupplyCraftEgress event stamped time, set the SeaSupplyCraft state, configured the waypoint for the path and scheduled StartMoving event. The StartMoving event scheduled EndMoving event to be occurred after moving time T_{move} , which in turn scheduled the ArrivalSeaSupplyCraftDepot event. Note that SeaSupplyCraftIngress event was the same event in the SupplyStation object while SeaSupplyCraftEgress was the same event in the OperatingBase object.

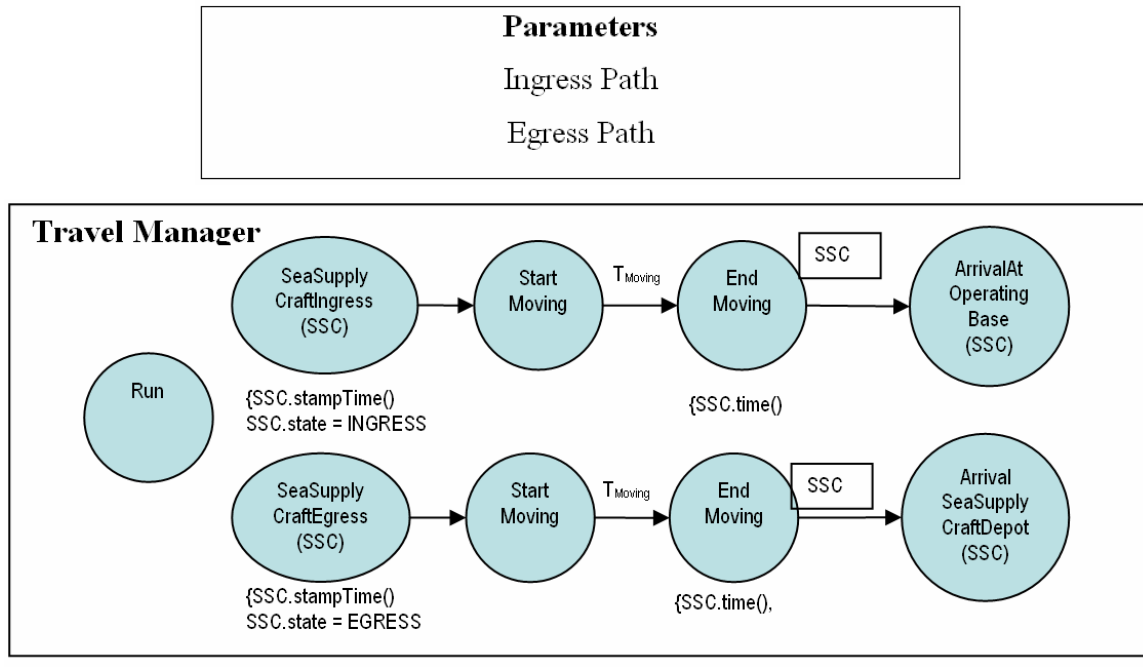

Figure 98. Event Graph for TravelManager Object

5.2.4.6 OperatingBase Listener Object

The event graph for the OperatingBase Listener Object is as shown in Figure 99. At the start of the simulation, the run event simply initialized the state variables and did not schedule any event. The ArrivalAtOperatingBase event updated the state of the SeaSupplyCraft to UnloadingState and also stamped the time of arrival. The SeaSupplyCraft was placed in the queue. The ArrivalAtOperatingBase then scheduled the startUnloading event if there was an available unloader. The StartUnloading event removed the first SeaSupplyCraft in the queue, received the queue delay, decremented the number of available unloaders, stamped the start unloading time and scheduled the EndSeaUnloading event after unloading time $T_{Unloading}$ has lapsed. The

EndSeaUnloading event updated the unloading time and incremented the number of available unloaders. It also scheduled StartUnloading event if there were SeaSupplyCraft in the queue. The end unloading event scheduled the SeaSupplyCraftEgress event. After the end of the unloading event, the OperatingBase object also updated the fuel level and computed the next time when fuelRequest event should have been scheduled based on the linear consumption rate. It also canceled the previously scheduled fuelRequest since the fuel level was updated. Note that ArrivalAtOperatingBase was the same event as in the TravelManager.

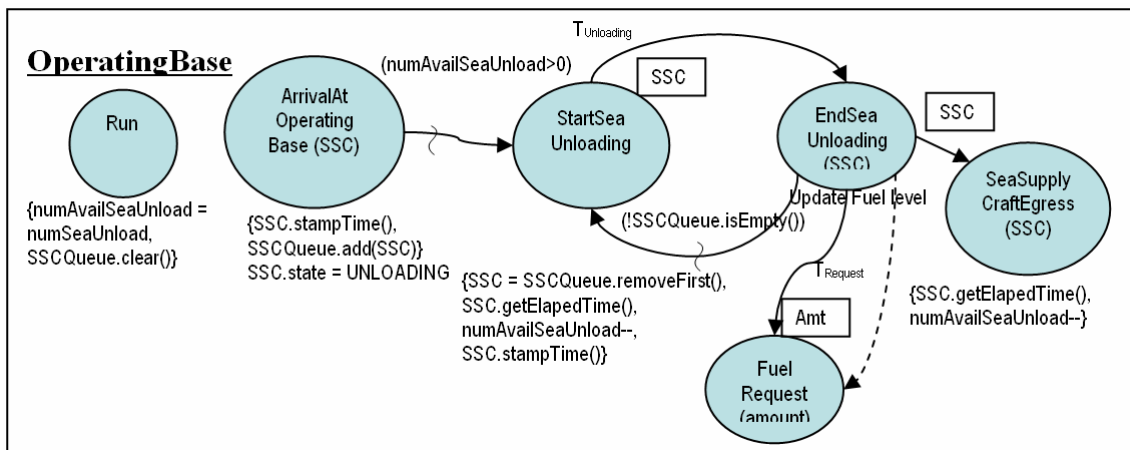
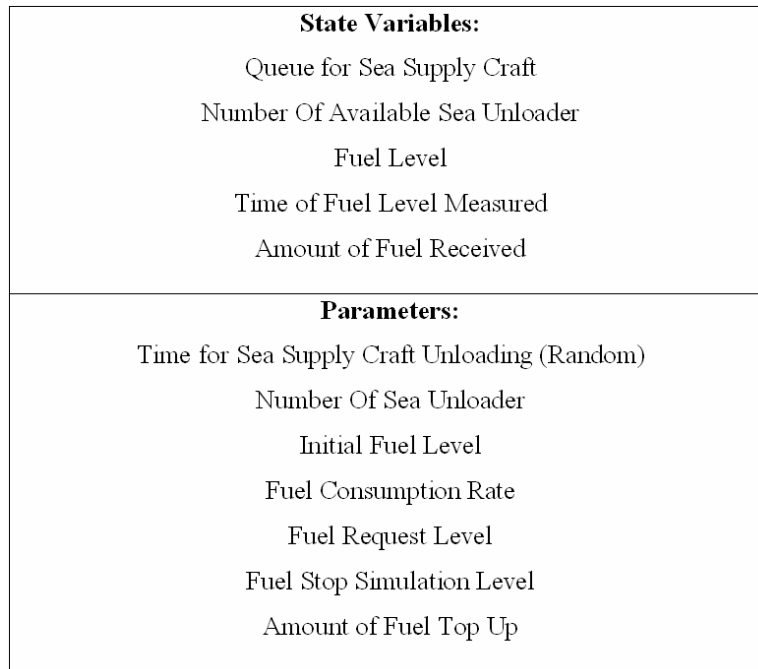

Figure 99. Event Graph for OperatingBase Object

5.2.5 SIMKIT Assumptions

There were several assumption made to simplify the simulation. They were categorized in the following groups.

5.2.5.1 Simulation

Weather conditions in the simulation assumed the effect of speed variation in relation to the maximum permissible movement and loading/unloading speed settings. It did not affect other factors such as supply ship arrival time or closure of the forward base supply capabilities.

5.2.5.2 Supply Ship

Loading operations were assumed to be completed after all supply demand has been loaded onto the supply connector even though the supply connectors were still underway to the operating base. Loading and unloading of the supply ship would be planned with best efficient approach such that loading and unloading of sea supply craft would not interfere with a helicopter. Supply ship had sufficient resources to load all supply crafts concurrently. Loading time was assumed to be a triangle distribution.

5.2.5.3 Supply Status

The simulation took the supply quantity as a combination of fuel, water, food and miscellaneous (weapons and ammunition).

5.2.5.4 Supply Connector

The supply connectors assumed a constant mean speed of movement throughout the delivery once it was deployed. The speed varied with weather conditions and assumed a triangle distribution.

5.2.5.5 Supply Connector Depot

The supply depot was not onboard both supply ship and operating base. The location was assumed to be close to the global supply ship at the mouth of the river such that the traveling time from the depot to the global supply ship was negligible.

5.2.5.6 Operating Base

Consumption rate was assumed to be a linear depreciation function. The operating base had sufficient resources to unload all supply connectors concurrently. Unloading time was assumed to be a triangle distribution.

5.2.6 SIMKIT Limitations

In addition to the assumptions which simplified the simulation, there were also limitations which the RST felt could improve the simulation in terms of user-friendliness and also in better modeling of the logistic process. These limitations were not implemented due to time limitation of the project study, but will definitely benefit future improvement. The limitations are grouped in the following sub-sections;

5.2.6.1 Simulation

Simulation did not support GUI interface for changing of variables. Time was limited for the complete implementation of the GUI interface. Simulation did not allow changing of consumption rate after the simulation started. Simulation did not cater for hostile attack on the entities such as a terrorist plan to deny the replenishment capability of the task force. Terrain is a simple representation of 2D map without terrain details and limitation of movement. Simulation programmer need to work out the exact path and speed variation.

5.2.6.2 Supply Ship

Simulation did not allow the changing of the re-supplying position of the supply ship once the simulation started.

5.2.6.3 Supply

Simulation did not allow the break down of supply into fuel, water, food and others.

5.2.7 EXTEND Model

5.2.7.1 Software

The second model used was EXTEND which is a discrete event model. The Extend model was a follow on to the SIMKIT model and was used to further analyze the riverine logistics problem. The Extend simulation was designed to replicate the flow of supplies from a supply ship to a forward operating base inland operating from a riverbank or on the river.

The model was developed to analyze the two best single logistic connectors determined by the SIMKIT model. The use of Extend allowed for the RST to derive performance variables about each basing alternative based on the capabilities of the LCU-2000 and SEACOR “Jim G”. The capabilities of both logistics connectors were modeled and affected by numerous factors to include speed, environment, connector capacity, and loading/unloading constraints. Since these factors and many others are involved in this complex operation of riverine logistics an analytical or algorithmic approach was difficult. Therefore, Extend allowed for the dynamic modeling of these variables.

The Extend model was time driven that allowed events to happen based upon a time scale. All activities in the model were simulated to happen in real time based upon an hour long time step. This allowed for the RST to examine the two logistics connectors and two basing alternatives interactions over time.

5.2.7.2 Set Up

The inputs to the model are summarized in Table 31. These inputs were a compilation of research completed by the RST in terms of basing alternatives, logistics connectors and the riparian environment on the Kampar River in Indonesia. Table 31

includes all assumptions and limitations of the Extend model as well as the distribution parameters and the hard inputs.

Parameter	Value	Description
1.EM2.0 Accurate Flow of Materiel	Output	Model outputs the exact amounts delivered by supply ship and received by basing alternative. Used as a check to ensure model is accounting materiel correctly.
A.EM2.1 Accurate Relay of Need	Output	Model outputs the exact amount needed by the basing alternative per supply event. Used as a check to ensure model is accurately asking for the correct amount of materiel each supply event.
1.EM2.1.1 Identifying Need	100%	RST assumed personnel did identify the need accurately 100% of the time. However this parameter is suspected of having significant impact on the results of this study and as such warrants further investigation.
a.Learning Effect	1.0	Beyond the scope of this study. However this parameter is suspected of having significant impact on the results of this study and as such has been further investigated in Appendix F.
b.Storage Accessibility	100%	RST assumed the basing alternative and RF personnel able to access storage all the time. However this parameter is suspected of having significant impact on the results of this study and as such warrants further investigation.
c.Following Procedure	100%	Beyond the scope of this study. However this parameter is suspected of having significant impact on the results of this study and as such has been further investigated in Appendix F.
2.EM2.1.2 Identifying Gap	Output	Calculated by model given inputs and drives the number of logistic connector transport events to achieve all materiel delivery.
a.Current Level	Output	Level of class of supply at time requested by model.
b.Max Storage Level (fuel) FOB	84000 gals	Total storage of fuel at config 1 basing alternative.
c.Max Storage Level (fuel) MOB	160000 gals	Total storage of fuel at config 2 basing alternative.
d.Max Storage Level (water) FOB	70000 gals	Total storage of drinking water at config 1 basing alternative.
e.Max Storage Level (water) MOB	79000 gals	Total storage of drinking water at config 2 basing alternative.
f.Max Storage Level (food) FOB	92 pallets	Total storage of food pallets at config 1 basing alternative.
g.Max Storage Level (food) MOB	55 pallets	Total storage of food pallets at config 2 basing alternative.
h.Hist Consumption Rate (fuel) FOB	~5600 gals/day	Model calculates based on optempo of SURC's, and basing alternative use. SURC fuel use is a triangular distribution minimum of 20, most likely of 21, and maximum of 25 per operating hour of SURC. Base fuel use is a triangular distribution minimum of 95, most likely of 96, and maximum of 98 per operating hour of the base.
i.Hist Consumption Rate (fuel) MOB	~10700 gals/day	Model calculates based on optempo of SURC's, and basing alternative use. SURC fuel use is a triangular distribution minimum of 20, most likely of 21, and maximum of 25 per operating hour of SURC. Base fuel use is a triangular distribution minimum of 290, most likely of 300, and maximum of 310 per operating hour of the base.

j.Hist Consumption Rate (water) FOB	~5600 gals/day	Model calculates based on # of personnel at base and gallons of water consumed per person. Personnel at base is a triangular distribution minimum of 350, most likely of 380, and maximum of 430 per day. On average a person uses 9.0 gallons for drinking, feeding and hygiene.
k.Hist Consumption Rate (water) MOB	~10700 gals/day	Model calculates based on # of personnel at base and gallons of water consumed per person. Personnel at base is a triangular distribution minimum of 500, most likely of 530, and maximum of 580 per day. On average a person uses 9.0 gallons for drinking, feeding and hygiene.
l.Hist Consumption Rate (food) FOB	~4661 Lbs/day	Model calculates based on # of personnel at base and lbs of food per meal. Personnel at base is a triangular distribution minimum of 350, most likely of 380, and maximum of 430 per meal. On average a person eats 3.7 lbs for breakfast, 2.82 for lunch, 3.58 for supper, and 2.82 for midrats.
m.Hist Consumption Rate (food) MOB	~3656 lbs/day	Model calculates based on # of personnel at base and lbs of food per meal. Personnel at base is a triangular distribution minimum of 500, most likely of 530, and maximum of 580 per meal. On average a person eats 5.6 lbs of ships stores per day and the boat team personnel eat 0.9 lbs of MRE's per day.
n.EM3.0 Total Movement Time	Output	Model calculates based upon all the logisitic connector time inputs.
3.EM2.1.3 Request Generation	100%	Requirement of system to always be able to generate a request.
4.EM2.1.4 Confirmation Ack.	100%	Requirement of system to always be able to generate a request.
B.EM2.2 Accuracy of Receipt	100%	RST assumed RF personnel did accurately receive materiel into storage 100% of the time. However this parameter is suspected of having significant impact on the results of this study and as such warrants further investigation.
1.EM2.2.1 Accuracy of Classify	100%	RST assumed RF personnel did accurately classify food as food and fuel as fuel 100% of the time. However this parameter is suspected of having significant impact on the results of this study and as such warrants further investigation.
a.Learning Effect	1.0	Beyond the scope of this study. However this parameter is suspected of having significant impact on the results of this study and as such has been further investigated in Appendix F.
b.Following Procedure	100%	Beyond the scope of this study. However this parameter is suspected of having significant impact on the results of this study and as such has been further investigated in Appendix F.
2.EM2.2.2 Accuracy of Count	100%	RST assumed RF personnel did accurately count materiel into storage 100% of the time. However this parameter is suspected of having significant impact on the results of this study and as such warrants further investigation.

a.Learning Effect	1.0	Beyond the scope of this study. However this parameter is suspected of having significant impact on the results of this study and as such has been further investigated in Appendix F.
b.Following Procedure	100%	Beyond the scope of this study. However this parameter is suspected of having significant impact on the results of this study and as such has been further investigated in Appendix F.
3.EM2.2.3 Report Sent	100%	Requirement of system to always be able to send report.
C.EM2.3 Accuracy of Storage	100%	RST assumed RF personnel did accurately store materiel 100% of the time. However this parameter is suspected of having significant impact on the results of this study and as such warrants further investigation.
1.EM2.3.1 Class Accuracy	100%	RST assumed RF personnel accurately separated materiel by class of supply 100% of the time. However this parameter is suspected of having significant impact on the results of this study and as such warrants further investigation.
a.Correct Location	100%	RST assumed RF personnel did place materiel in the correct location 100% of the time. However this parameter is suspected of having significant impact on the results of this study and as such warrants further investigation.
b.Correct Labeling	100%	RST assumed all materiel was correctly labeled as what type of supply and the RF personnel read the label correctly 100% of the time. However this parameter is suspected of having significant impact on the results of this study and as such warrants further investigation.
c.Learning Effect	1.0	Beyond the scope of this study. However this parameter is suspected of having significant impact on the results of this study and as such has been further investigated in Appendix F.
2.EM2.3.2 Size Accuracy	100%	RST assumed RF personnel accurately stored materiel on logistic connector and basing alternative 100% of the time. However this parameter is suspected of having significant impact on the results of this study and as such warrants further investigation.
a.Matching Cargo by square feet	100%	RST assumed RF personnel accurately stored materiel by square feet 100% of the time. However this parameter is suspected of having significant impact on the results of this study and as such warrants further investigation.
b.Learning Effect	1.0	Beyond the scope of this study. However this parameter is suspected of having significant impact on the results of this study and as such has been further investigated in Appendix F.
3.EM2.3.3 Volume Accuracy	100%	RST assumed RF personnel accurately stored materiel on logistic connector and basing alternative 100% of the time. However this parameter is suspected of having significant impact on the results of this study and as such warrants further investigation.

a. Matching Cargo by cubic feet	100%	RST assumed RF personnel accurately stored materiel by cubic feet 100% of the time. However this parameter is suspected of having significant impact on the results of this study and as such warrants further investigation.
b. Learning Effect	1.0	Beyond the scope of this study. However this parameter is suspected of having significant impact on the results of this study and as such has been further investigated in Appendix F.
4. EM2.3.4 Weight Accuracy	100%	RST assumed RF personnel accurately stored materiel on logistic connector and basing alternative 100% of the time. However this parameter is suspected of having significant impact on the results of this study and as such warrants further investigation.
a. Overloading Logistic Connector	0%	RST assumed RF personnel accurately stored materiel by weight 100% of the time. However this parameter is suspected of having significant impact on the results of this study and as such warrants further investigation.
b. Learning Effect	1.0	Beyond the scope of this study. However this parameter is suspected of having significant impact on the results of this study and as such has been further investigated in Appendix F.
D. EM2.4 Performance of Issue Items	100%	RST assumed RF personnel issued items perfectly 100% of the time. However this parameter is suspected of having significant impact on the results of this study and as such warrants further investigation.
1. EM2.4A Accuracy of Fulfillment	100%	RST assumed RF personnel accurately fulfilled materiel requests 100% of the time. However this parameter is suspected of having significant impact on the results of this study and as such warrants further investigation.
a. EM2.4.1 Accuracy of Order	100%	RST assumed RF personnel issued the desired item 100% of the time. However this parameter is suspected of having significant impact on the results of this study and as such warrants further investigation.
1. Learning Effect	1.0	Beyond the scope of this study. However this parameter is suspected of having significant impact on the results of this study and as such has been further investigated in Appendix F.
2. Accuracy of Order	100%	RST assumed RF personnel issued the desired item 100% of the time. However this parameter is suspected of having significant impact on the results of this study and as such warrants further investigation.
b. EM2.4.3.1 Composition Accuracy	100%	RST assumed RF personnel issued the desired number of items 100% of the time. However this parameter is suspected of having significant impact on the results of this study and as such warrants further investigation.
1. Learning Effect	1.0	Beyond the scope of this study. However this parameter is suspected of having significant impact on the results of this study and as such has been further investigated in Appendix F.
2. Composition Accuracy	100%	RST assumed RF personnel issued the desired number of items 100% of the time. However this parameter is suspected of having significant impact on the results of this study and as such warrants further investigation.

1.EM2.4B Preparation Time for Issue	0 hours	Beyond the scope of this study. However this parameter is suspected of having significant impact on the results of this study and as such warrants further investigation.
a.EM2.4.2 Pre-Position Time	0 hours	Beyond the scope of this study. However this parameter is suspected of having significant impact on the results of this study and as such warrants further investigation.
1.Movement for pre-position	0 hours	Beyond the scope of this study. However this parameter is suspected of having significant impact on the results of this study and as such warrants further investigation.
2.Material Search Time	0 hours	Beyond the scope of this study. However this parameter is suspected of having significant impact on the results of this study and as such warrants further investigation.
3.Learning Effect	1.0	Beyond the scope of this study. However this parameter is suspected of having significant impact on the results of this study and as such has been further investigated in Appendix F.
b.EM2.4.3.2 Composition Time	0 hours	Beyond the scope of this study. However this parameter is suspected of having significant impact on the results of this study and as such warrants further investigation.
1.Organization Time	0 hours	Beyond the scope of this study. However this parameter is suspected of having significant impact on the results of this study and as such warrants further investigation.
1.Learning Effect	1.0	Beyond the scope of this study. However this parameter is suspected of having significant impact on the results of this study and as such has been further investigated in Appendix F.
c.EM2.4.4 Containerization Time	0 hours	Beyond the scope of this study. However this parameter is suspected of having significant impact on the results of this study and as such warrants further investigation.
1.Packaging Retrieval Time	0 hours	Beyond the scope of this study. However this parameter is suspected of having significant impact on the results of this study and as such warrants further investigation.
2.Organizing Material for Package	0 hours	Beyond the scope of this study. However this parameter is suspected of having significant impact on the results of this study and as such warrants further investigation.
3.Packaging Time	0 hours	Beyond the scope of this study. However this parameter is suspected of having significant impact on the results of this study and as such warrants further investigation.
4.Issue Time	0 hours	Beyond the scope of this study. However this parameter is suspected of having significant impact on the results of this study and as such warrants further investigation.
5.Learning Effect	1.0	Beyond the scope of this study. However this parameter is suspected of having significant impact on the results of this study and as such has been further investigated in Appendix F.
E.EM2.5 Supply Train Performance	Output	Model calculates based on inputs.
1.EM2.5.1 Survivability	90%, 95%, 99%	Inputs to model. Test of each logistics connector performing its mission with 1 out of ten, 1 out of 20, and 1 out of 100 transport events where a logistic connector is lost.
a.Susceptibility	Varies	Beyond the scope of this study. However this parameter is suspected of having significant impact on the results of this study and as such warrants further investigation.

b.Vulnerability	Varies	Beyond the scope of this study. However this parameter is suspected of having significant impact on the results of this study and as such warrants further investigation.
2.EM2.5.2 Route Status	90%	Percentage of time the route is open for the logistic connector to perform a transport event.
a.EM2.5.2.1 Route Availability	90%	RST determined that wind > 40kts and sea state >5 (12 ft) would shut down the route for 24 hours. Each weather effect occurs 10% of the time and the RST assumed that the two effects are significantly dependent therefore a route availability would be 90%. However, this parameter is suspected of having significant impact on the results of this study and as such warrants further investigation.
1.Weather Effect	0.9	See Table XX for various input parameters and how they affected route availability
2.Water Terrain Effect	1.0	See Table XX for various input parameters and how they affected route availability
3.Route Knowledge	100%	RST assumed RF personnel had knowledge of the route 100% of the time. However this parameter is suspected of having significant impact on the results of this study and as such warrants further investigation.
4.Route Certainty	100%	RST assumed RF personnel were 100% certain about condition of route 100% of the time. However this parameter is suspected of having significant impact on the results of this study and as such warrants further investigation.
5.Resource Effect	1.0	RST assumed RF personnel had the resources 100% of the time. Therefore there was not effect from lack of resources. However this parameter is suspected of having significant impact on the results of this study and as such warrants further investigation.
6.Political Constraints	100%	RST assumed RF personnel had no political restraints 100% of the time. However this parameter is suspected of having significant impact on the results of this study and as such warrants further investigation.
7.Hostility Effect	1.0	RST assumed that the hostile forces in the area would not be able to close the supply route due to the Indonesian Army patrolling the river banks. However an ambush would affect the chance of losing a logistic connector and is accounted for in EM 2.5.1 Survivability. However, this parameter is suspected of having significant impact on the results of this study and as such warrants further investigation.
b.EM2.5.2.2 Route Maintainability	100%	Beyond the scope of this study. However this parameter is suspected of having significant impact on the results of this study and as such warrants further investigation.
1.Hostility Effect	1.0	RST assumed that the hostile forces in the area would not be able to close the supply route due to the Indonesian Army patrolling the river banks. However an ambush would affect the chance of losing a logistic connector and is accounted for in EM 2.5.1 Survivability. However, this parameter is suspected of having significant impact on the results of this study and as such warrants further investigation.

2.Route Knowledge	100%	Beyond the scope of this study. However this parameter is suspected of having significant impact on the results of this study and as such warrants further investigation.
3.Resource Effect	1.0	Beyond the scope of this study. However this parameter is suspected of having significant impact on the results of this study and as such warrants further investigation.
4.Learning Effect	1.0	Beyond the scope of this study. However this parameter is suspected of having significant impact on the results of this study and as such has been further investigated in Appendix F.
2.EM3.0 Total Movement Time	Output	Model calculates dependent on all factors in the model.
A.EM3.1 Loading Time	Varies	Model calculates based on all the factors and effects dealing with loading.
1.EM3.1.1 Stage Time	Varies	Calculated by model given inputs and drives the amount of time the logistic connector was on loading supplies per transport event.
a.Travel Time to Supply Hub	0 hours	RST assumed the logistic connector would be on station and not keep the supply ship waiting at all times.
b.Maneuvering Time	15 min.	RST assumed the most time to maneuver in preparation for mooring in the worst weather conditions the logisitic connector did operate.
c.Mooring Time	15 min.	RST assumed the most time to moor, in the worst weather conditions, in which the logisitic connectors did operate.
d.Delay Time due to Preparation	0 hours	RST assumed that the supply ship would always be prepared to off load materiel as needed.
e.Safety Effect	1.0	RST assumed that all events were completed as safely as possible therefore there were no mishaps or personnel hurt and the events were not hinder. However, this parameter is suspected of having significant impact on the results of this study and as such warrants further investigation.
f.Weather Effect	Input	See Table XX for various input parameters and how they affected time.
g.Learning Effect	1.0	Beyond the scope of this study. However this parameter is suspected of having significant impact on the results of this study and as such has been further investigated in Appendix F.
h.Illumination Effect	Input	See Table XX for various input parameters and how they affected time.
2.EM3.1.2 Lift Time	Varies	Model calculates based upon all the factors and effects dealing with lift.
a.Rigging Time	0 hours	RST assumed the supply ship would have all necessary equipment ready for transfer and the connecting of hoses and pallets to crane would be negligible.
b.Transfer Time - Supply Ship Liquids	600 gpm	RST assumed the smallest transfer rate found on Naval replenishment ships in the fleet.
c.Transfer Time - Supply Ship Pallets	2 per min.	RST assumed the smallest transfer rate found on Naval replenishment ships in the fleet.
d.Safety Effect	1.0	RST assumed that all events were completed as safely as possible therefore there were no mishaps or personnel hurt and the events were not hinder. However, this parameter is suspected of having significant impact on the results of this study and as such warrants further investigation.

e.Weather Effect	Input	See Table XX for various input parameters and how they affected time.
f.Learning Effect	1.0	Beyond the scope of this study. However this parameter is suspected of having significant impact on the results of this study and as such has been further investigated in Appendix F.
g.Illumination Effect	Input	See Table XX for various input parameters and how they affected time.
3.EM3.1.3 Set In Place Time	0 hours	RST assumed this parameters inputs would all be zero or accounted in other categories for the model. However, this parameter is suspected of having significant impact of the results of this study and as such warrants further investigation.
a.Placing Time	0 hours	RST assumed the placing of pallets and containers in the logistics connector was part of the transfer time. However this parameter is suspected of having significant impact on the results of this study and as such warrants further investigation.
b.Securing for Sea Time	0 hours	RST assumed that the crew of the logistics connector would be able to secure for sea as quickly as the cargo could be loaded. However, this parameter is suspected of having significant impact on the results of this study and as such warrants further investigation.
c.Ballasting Time	0 hours	RST assumed the crew of the logistics connector would be able to ballast out the connector as the cargo is loaded. However this paramter is suspectetd of having significant impact on the results of this study and as such warrants further investigation.
d.Safety Effect	1.0	RST assumed that all events were completed as safely as possible therefore there were no mishaps or personnel hurt and the events were not hinder. However, this parameter is suspected of having significant impact on the results of this study and as such warrants further investigation.
e.Weather Effect	Input	See Table XX for various input parameters and how they affected time.
f.Learning Effect	1.0	Beyond the scope of this study. However this parameter is suspected of having significant impact on the results of this study and as such has been further investigated in Appendix F.
g.Illumination Effect	Input	See Table XX for various input parameters and how they affected time.
B.EM3.2 Transport Time	Varies	Model calculates time based on inputs and effects.
1.EM3.2.1 Start Time	30 min.	RST assumed the most time to begin travel.
a.Casting Off Time	15 min.	RST assumed the most time to cast off, in the worst weather conditions, in which the logisitic connectors did operate.
b.Maneuvering Time	15 min.	RST assumed the most time to maneuver in preparation for travel in the worst weather conditions the logisitic connector did operate.

c.Equipment Check Time	0 hours	RST assumed that the crew of the logistics connector checked all equipment and were ready for sea at all times.
d.Safety Effect	1.0	RST assumed that all events were completed as safely as possible therefore there were no mishaps or personnel hurt and the events were not hinder. However, this parameter is suspected of having significant impact on the results of this study and as such warrants further investigation.
e.Weather Effect	Input	See Table XX for various input parameters and how they affected time.
f.Learning Effect	1.0	Beyond the scope of this study. However this parameter is suspected of having significant impact on the results of this study and as such has been further investigated in Appendix F.
g.Illumination Effect	Input	See Table XX for various input parameters and how they affected time.
2.EM3.2.2 Travel Time	Varies	Model calculates based upon all the factors and effects dealing with travel.
a.Weather Effect	Input	See Table XX for various input parameters and how they affected time.
b.Illumination Effect	Input	See Table XX for various input parameters and how they affected time.
c.Obscurant Effect	Input	See Table XX for various input parameters and how they affected time.
e.Distance	40 nm	RST determined from point of anchorage of supply ship to where the FOB or MOB would be located. However this parameter is suspected of having significant results of this study and as such warrants further investigation.
f.Speed - LCU 2000	8-12 kts	Triangular distribution with a minimum of 8, maximum of 12 and most likely value of 10. However this paramter is suspected of having significant results on this study and as such warrants further investigation.
g.Speed - SEACOR "Jim G"	7-11 kts	Triangular distribution with a minimum of 7, maximum of 11 and most likely value of 9. However this paramter is suspected of having significant results on this study and as such warrants further investigation.
h.Hostility Effect	Input	See Table XX for various input parameters and how they affected time.
i.Navigation Effect	Input	See Table XX for various input parameters and how they affected time.
j.Sand Effect	Input	See Table XX for various input parameters and how they affected time.
k.Ice Effect	Input	See Table XX for various input parameters and how they affected time.
l.Learning Effect	1.0	Beyond the scope of this study. However this parameter is suspected of having significant impact on the results of this study and as such has been further investigated in Appendix F.
3.EM3.2.3 Stop Time	30 min.	RST assumed the most time to end travel.
a.Maneuvering Time	15 min.	RST assumed the most time to maneuver in preparation for travel in the worst weather conditions the logisitic connector did operate.

b.Mooring or Beaching Time	15 min.	RST assumed the most time to maneuver in preparation for travel in the worst weather conditions the logistic connector did operate.
c.Rigging for Unload Time	0 hours	RST assumed the logistics connector would have all necessary equipment ready for transfer and the connecting of hoses and pallets onto forklift would be negligible.
d.Weather Effect	Input	See Table XX for various input parameters and how they affected time.
e.Safety Effect	1.0	RST assumed that all events were completed as safely as possible therefore there were no mishaps or personnel hurt and the events were not hinder. However, this parameter is suspected of having significant impact on the results of this study and as such warrants further investigation.
f.Illumination Effect	Input	See Table XX for various input parameters and how they affected time.
g.Learning Effect	1.0	Beyond the scope of this study. However this parameter is suspected of having significant impact on the results of this study and as such has been further investigated in Appendix F.
C.EM3.3 Unload Time	Varies	Model calculates dependent on all factors in the model.
1.EM3.3.1 Lift Time	0 hours	RST assumed the logistics connector did not have any delay due to moving of materiel. This parameter is also accounted for in the transfer time of each logistics connector. However this parameter is suspected of having a significant impact on the results of this study and as such warrants further investigation.
a.Rigging Time	0 hours	RST assumed the logistic connector had all the necessary equipment ready for transfer and the connecting of hoses and pallets to crane would be negligible.
b.Transfer Time - LCU 2000 Fuel	100 gpm	RST assumed the smallest transfer rate found on LCU 2000 craft.
c.Transfer Time - LCU 2000 Pallets	4 per min.	RST assumed the smallest transfer by forklifts at the basing alternative.
d.Transfer Time - LCU 2000 Water	100 gpm	RST assumed the smallest transfer rate found on a SIXCON pump.
e.Transfer Time - SEACOR Fuel	150 gpm	RST assumed the smallest transfer rate found on SEACOR "Jim G".
f.Transfer Time - SEACOR Pallets	2 per min.	RST assumed the smallest transfer rate found on SEACOR "Jim G".
g.Transfer Time - SEACOR Water	300 gpm	RST assumed the smallest transfer rate found on a SEACOR "Jim G".
h.Safety Effect	1.0	RST assumed that all events were completed as safely as possible therefore there were no mishaps or personnel hurt and the events were not hinder. However, this parameter is suspected of having significant impact on the results of this study and as such warrants further investigation.
i.Weather Effect	Input	See Table XX for various input parameters and how they affected time.
j.Learning Effect	1.0	Beyond the scope of this study. However this parameter is suspected of having significant impact on the results of this study and as such has been further investigated in Appendix F.

k.Illumination Effect	Input	See Table XX for various input parameters and how they affected time.
2.EM3.3.2 Stage Time	0 hours	RST assumed the basing alternative was always ready to unload the materiel from the logistics connectors. However this paramter is suspected of having significant impact on the results of this study and as such warrants further investigation.
a.Delay due to Preparation Time	0 hours	RST assumed the basing alternavtive was always prepared to receive and unload the supplies from the logistics connectors. However this parameter is suspected of having significant impact on the results of this study and as such warrants further investigation.
b.Storing Time on Base	0 hours	RST assumed that the logistics connector would unload all materiel as quickly as the equipment allowed and the base would be able to unload all materiel at the maximum rate of the logistics connector. However this parameter is suspected of having significant impact on the results of this study and as such warrants further investigation.
c.Safety Effect	1.0	RST assumed that all events were completed as safely as possible therefore there were no mishaps or personnel hurt and the events were not hinder. However, this parameter is suspected of having significant impact on the results of this study and as such warrants further investigation.
d.Weather Effect	Input	See Table XX for various input parameters and how they affected time.
e.Learning Effect	1.0	Beyond the scope of this study. However this parameter is suspected of having significant impact on the results of this study and as such has been further investigated in Appendix F.
3.EM4.0 Recovery Time Personnel	0 hours	RST assumed host nation would provide medical facilites and critical care centers to stabilize and begin the recovery of personnel. However, this parameter is suspected of having significant impact on the results of this study and as such warrants further investigation.
4.EM4.0 Disposition Safety Materiel	100%	Beyond the scope of this study. However this parameter is suspected of having significant impact on the results of this study and as such warrants further investigation.
A.EM4.2 Disposition Safety	100%	Beyond the scope of this study. However this parameter is suspected of having significant impact on the results of this study and as such warrants further investigation.
1.EM4.2.1 Handling Safety	100%	Beyond the scope of this study. However this parameter is suspected of having significant impact on the results of this study and as such warrants further investigation.
a.Correct Retrieval	100%	Beyond the scope of this study. However this parameter is suspected of having significant impact on the results of this study and as such warrants further investigation.
b.Safely Received	100%	Beyond the scope of this study. However this parameter is suspected of having significant impact on the results of this study and as such warrants further investigation.
c.Correct Packaging	100%	Beyond the scope of this study. However this parameter is suspected of having significant impact on the results of this study and as such warrants further investigation.

d.Following Procedure	100%	Beyond the scope of this study. However this parameter is suspected of having significant impact on the results of this study and as such has been further investigated in Appendix F.
2.EM4.2.2 Materiel Safeguard Correct	100%	Beyond the scope of this study. However this parameter is suspected of having significant impact on the results of this study and as such warrants further investigation.
a.Correct Control	100%	Beyond the scope of this study. However this parameter is suspected of having significant impact on the results of this study and as such warrants further investigation.
b.Correct Isolation	100%	Beyond the scope of this study. However this parameter is suspected of having significant impact on the results of this study and as such warrants further investigation.
c.Following Procedure	100%	Beyond the scope of this study. However this parameter is suspected of having significant impact on the results of this study and as such has been further investigated in Appendix F.
3.EM4.2.3 Retrograde	100%	Beyond the scope of this study. However this parameter is suspected of having significant impact on the results of this study and as such warrants further investigation.
a.Learning Effect	1.0	Beyond the scope of this study. However this parameter is suspected of having significant impact on the results of this study and as such has been further investigated in Appendix F.
b.Accurate Identification	100%	Beyond the scope of this study. However this parameter is suspected of having significant impact on the results of this study and as such warrants further investigation.
c.Following Procedure	100%	Beyond the scope of this study. However this parameter is suspected of having significant impact on the results of this study and as such has been further investigated in Appendix F.
4.EM4.2.4 Identify for Disposal	100%	Beyond the scope of this study. However this parameter is suspected of having significant impact on the results of this study and as such warrants further investigation.
a.Learning Effect	1.0	Beyond the scope of this study. However this parameter is suspected of having significant impact on the results of this study and as such has been further investigated in Appendix F.
b.Accurate Identification	100%	Beyond the scope of this study. However this parameter is suspected of having significant impact on the results of this study and as such warrants further investigation.
c.Following Procedures	100%	Beyond the scope of this study. However this parameter is suspected of having significant impact on the results of this study and as such has been further investigated in Appendix F.

5.EM5.0 Operational Feasibility	100.0%	RST assumed the logistics connector modeled were feasible after the feasibility screening.
A.EM5.1 Reliability	100.0%	Beyond the scope of this study. However this parameter is suspected of having significant impact on the results of this study and as such warrants further investigation.
B.EM5.2 Availability	100.0%	Beyond the scope of this study. However this parameter is suspected of having significant impact on the results of this study and as such warrants further investigation.
C.EM5.3 Maintainability	100.0%	Beyond the scope of this study. However this parameter is suspected of having significant impact on the results of this study and as such warrants further investigation.
D.EM5.4 Transportability	100.0%	Beyond the scope of this study. However this parameter is suspected of having significant impact on the results of this study and as such warrants further investigation.
E.EM5.5 Manpower Suitability	100.0%	Beyond the scope of this study. However this parameter is suspected of having significant impact on the results of this study and as such warrants further investigation.

Table 31. Assumptions, stochastic, and deterministic parameters of model.

In Table 32 the RST determined the percentage of time each one of the effects would occur and how they affected the logistics connectors. The RST made the assumption that all effects would have a similar affect on every river borne logistic connector.

Speed Reduction Factor					Capacity reduction Factor				
Water Terrain	Navigable	Constrained	Restricted		Navigable	Constrained	Restricted		
% Occurrence	80%	20%	0%		80%	20%	0%		
LCU 2000	0	0.5	1		0	0	1		
Seacor	0	0.5	1		0	0	1		
Route Availability	100%	100%	100%						
Obscurant	Clear	1-2k yds	500-1k yds	<500 yds	Clear	1-2k yds	500-1k yds	<500 yds	
% Occurrence	40%	30%	20%	10%	40%	30%	20%	10%	
LCU 2000	0	0.3	0.6	0.9	0	0	0	0	
Seacor	0	0.3	0.6	0.9	0	0	0	0	
Sand	None	Dust Storm	Sand Storm		None	Dust Storm	Sand Storm		
LCU 2000	0	0	0		0	0	0		
Seacor	0	0	0		0	0	0		
*Sand storms do not occur in the RST AO therefore not a consideration in the model.									
Wind	<20 kts	>20 - <40 kts	>40 kts		<20 kts	>20 - <40 kts	>40 kts		
% Occurrence	60%	30%	10%		60%	30%	10%		
LCU 2000	0	0.2	1		0	0	1		
Seacor	0	0.2	1		0	0	1		
Route Availability	100%	100%	0%						
Sea State	<S.S. 3	>3 - <5 S.S.	> S.S.5		<S.S. 3	>3 - <5 S.S.	> S.S.5		
% Occurrence	60%	30%	10%		60%	30%	10%		
LCU 2000	0	0.5	1		0	0	1		
Seacor	0	0.5	1		0	0	1		
Route Availability	100%	100%	0%						
Night	Full	Half	New		Full	Half	New		
LCU 2000	0	0	0		0	0	0		
Seacor	0	0	0		0	0	0		
*RST determined by 2012 illumination will not be a factor in operating logistic connectors.									
Hostility	None	Light	Damaging	Deadly	None	Light	Damaging	Deadly	
% Occurrence	70%	25%	4%	1%	70%	25%	4%	1%	
LCU 2000	0	0	1	1.1	0	0	0	0	
Seacor	0	0	1	1.1	0	0	0	0	
Route Availability	100%	100%	100%	100%					
Ice	Cold	Light	Storm		Cold	Light	Storm		
LCU 2000	0	0	0		0	0	0		
Seacor	0	0	0		0	0	0		
*Ice storms do not occur in the RST AO therefore not a consideration in the model.									

Table 32. Percentage of time effects occur and there effect on the logistic connectors.

5.2.7.3 Data Outputs

The overarching metrics that were useful in comparing the LCU-2000 against the SEACOR “Jim G” are described below. Each score for each type of configuration was deduced by averaging 30 runs in order to ensure an adequate sample size.

Operational availability of the SURC’s due to fuel was measured by the number of times the storage capacity on the base reached a level of two days worth of supply or roughly 15 % of total. This was determined by the RST as the amount that the operational commander would limit operations in order to conserve ready fuel levels to maintain the basing alternative operating and plan for any contingencies.

Operational habitability of the base due to food and water was measured by the number of times the storage capacity on the base reached a level of two days worth of supply or roughly 15% of total. This was determined by the RST as the amount that the operational commander would limit operations in order to conserve ready food and water levels to maintain basing alternative operating and plan for any contingencies.

Throughput metric was measured by determining the total amount of materiel moved per transport event divided by the total amount of time per transport event. This metric allowed the RST to evaluate how each logistics connector performed given all the inputs of the model over time. Each throughput measurement was then averaged over the 180 days to find the averaged maintained throughput for each logistics connector.

Supply ship on-station time measured the length of time the supply ship was at the logistics rendezvous point to off-load all materiel needed by the RF. This metric allowed for the RST to see which basing and logistic configuration achieved the goal of less than 24 hours supply ship on-station time. Percent level of storage for fuel, water and food measured the average level of supply at the basing alternative over the entire operation length of 180 days. This metric allowed for the RST to compare modeling configurations with regard to how closely they operated near the threshold. The number of logistic connectors lost is the measurement of an average amount of

connectors lost over the 180 day operation. This metric allowed for the RST to compare the survivability of each operation and how costly the movement of materiel would be in terms of lost dollars and personnel.

5.2.7.4 Software Processes and Limitations

Extend modeling of Riverine logistics gave the RST a unique insight into how the flow of materiel would happen and the different problems that would be encountered. The flow of materiel in Extend is separated into hierarchical blocks to make the model more user friendly Figure 100.

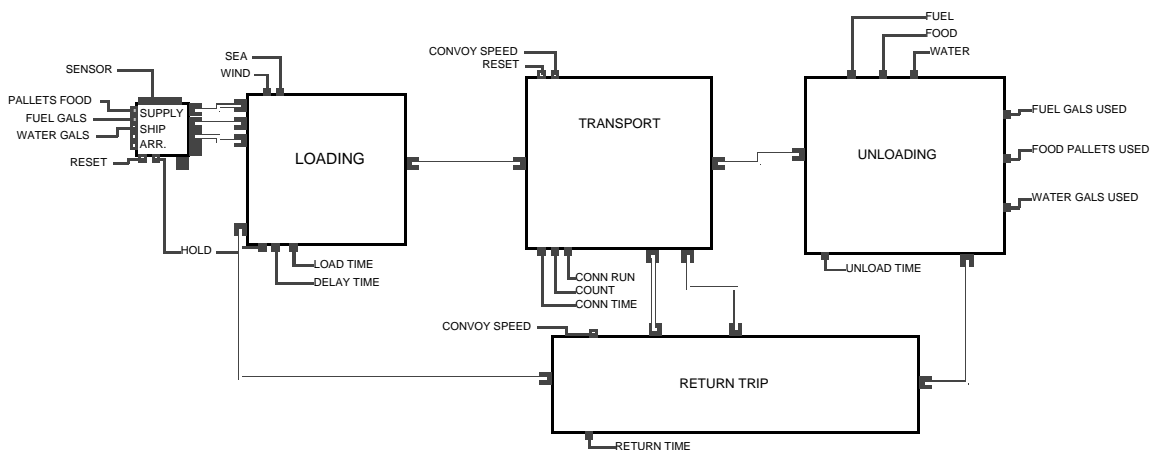

Figure 100. Extend hierarchical blocks

The first block is the Supply Ship Arrival block. This block entails the different speeds that the supply ship can travel in order to set the supply ship cycle time. Inside this block are the amounts of materiel that needs to be transported to the basing alternative. The next block is the loading block. This block takes all the necessary materiel to be moved in terms of fuel, water and food and turns them into a single batched item for the logistics connector to move. The amount of each commodity that is batched is dependent upon the priority of the materiel that needs to be moved and the capacity of the logistic connector. The priority of materiel was fuel followed by water and finally pallets of food. Because the logistics connectors were always limited by gross

tonnage and not deck space (cubic feet), the RST designed the model to take into account that only certain combinations of materiel could be carried each time. For example an LCU-2000 can carry 70,000 gallons of fuel but would only be able to carry 10,000 gallons of water and no pallets of food. All of these factors were taken into account and depending on the amount of each commodity of materiel a best fit was hard coded into the blocks to limit the number of capacity configurations needed to be modeled.

Once the materiel is loaded the convoy travels up the river. This block included the effects such as water terrain, obscurants, wind, sea state, and hostilities on speed. Also in this block was the survivability option that the RST varied for each configuration. As the connector traveled up the river the total amount of time was recorded using timer blocks.

If the connector made the trip to the basing alternative and was not lost the unloading process would begin. This process is based upon the amount of materiel that was loaded and the longest time to off-load an individual commodity. The RST made the assumption that the logistic connector would be able to off-load all three types of commodities at the same time, therefore the one commodity with the slowest unload time would be the limiting factor.

As soon as all materiel was unloaded the logistic connector would enter the return trip block in order to travel down the river back to the supply ship for the next load if needed. If the supply ship was completely unloaded already the logistic connector would just sit and wait for the next supply ship to arrive. Travel back down the river also included the effects of water terrain, obscurants, wind, sea state, and hostilities on speed.

The limitations discovered in Extend mostly depended on the ordering of the blocks and particular block functions. The batching of supplies required that at least one of each type of commodity be batched each time. This limited the model because the RST had to make the assumption that every transport event carried fuel, water, and food. Forcing the reservation of space for each commodity is not necessarily how a load master would load-out the logistic connector in order to maximize the amount of materiel each connector run. The second limitation has to deal with the ordering of the blocks. To

ensure that the proper amount of each commodity was carried and did not exceed the capacity of the logistics connector, gates were implemented into the model to prevent the calculation of supplies until the logistic connector was in place to receive the on-load.

5.3 REPAIR GROUP

5.3.1 Software and Setup

The RST Repair Group used EXTEND version 6.0.8 to conduct the modeling the RF maintenance function. The foundation for this model was based upon queuing theory, whereby the fundamental DOTMLPF resources of SURC’s, maintenance personnel and maintenance bays were employed according to the RST scenario’s operational cycle, illustrated below in Figure 101.

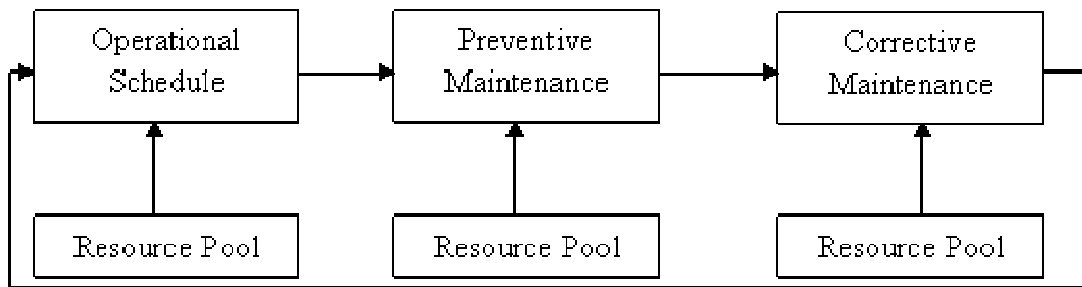

Figure 101. RF Maintenance Function Model Block Diagram

The intent of this model was to show utilization rates of maintenance personnel and maintenance facilities based over a six month period within the confines of a twelve-hour work day. These utilization rates are directly related to the RST’s maintenance alternatives of 1) increasing the number of maintenance personnel, 2) varying the number of maintenance bays between one and two, and 3) increasing the number of SURC’s deployed with the RF, which were all part of the resource pool.

The SURC’s inherent availability, or A_i , reported by Raytheon in the March 26 2007 SURC FRACAS indicated an A_i of 98.45%.³⁶⁹ However, this figure was based upon mean time between failure (MTBF) and mean time to repair (MTTR) alone, and did not account for mean corrective repair time (MCRT), mean preventive repair time

(MPRT), mean administrative delay time (MADT) or mean supply response time (MSRT). The RST defined operational availability as:

$$A_o = \frac{MTBF}{MTBF + MCRT + MPRT + MSRT}$$

RST Operational Availability³⁷⁰

Please note that the RST incorporated MADT into the MCRT and MPRT functions of the RF maintenance model as inherent delays involving a normal distribution between .5 and 1.5 hours.

The first input to this model were the preventive maintenance parameters, defined by the U.S. Marine Corps SURC Maintenance and Service Plan, Figure 102, as it provided the periodicity, the type of maintenance, the labor hours and the required consumable materials required for each preventive maintenance check. For the purposes of the RST scenario, annual and semi-annual checks were omitted, as these checks were completed during the pre-deployment phase.

PM ACTIONS (USMC)	Periodicity	LABOR				
		Min	Qty	Adj	Tot Min	Hours
SERVICE FUEL TANK	Monthly					
Drain FO Tank water off		15	1	12	180	3
Drain FO Tank Filters water off		5	2	12	120	2
Properly Dispose of Hazardous Material		5	1	12	60	1
REMOVE AND CLEAN SEA WATER STRAINERS	Monthly					
Remove and Clean Sea Water Strainers		15	2	12	360	6
GREASE WATERJET THRUST BEARING AND STEERING RODS	Quarterly					
Grease Thrust Bearing		5	1	4	20	0.33
Grease Steering Rods		10	1	4	40	0.67
(Second Waterjet)						1

Figure 102. SURC Preventive Maintenance Example³⁷¹

The second input to this model, the corrective maintenance parameters, was derived from a recent Reliability, Maintainability and Availability (RMA) report (Figure

103), from Raytheon Integrated Defense Systems, which provided the percent of failures by system.

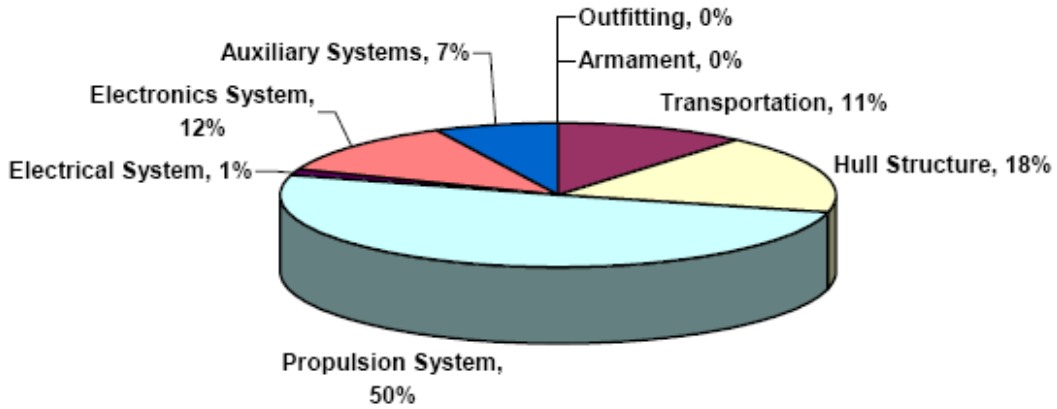

Figure 103. 2006 SURC RMA Report Percent of Failures by System³⁷²

The RST used these percentages of failures in conjunction with a SURC failure report provided by NSWCCD Little Creek (Table 33), that listed the mean time to repair (MTTR) for such failures.³⁷³

SYSTEM	ACTION	REPAIR TIME (hrs)
Exhaust Hanger Bracket	Installed bolts on port exhaust bracket	1.61
SURC Hull Dimensions	Repaired. All holes filled with welder.	5.97
SURC Trailer Assy.	Welded the rear bunk supports.	12.34

Table 33. SURC Failure and Maintenance Report Excerpt

In order to generate a likelihood of the type of system failure in terms of Auxiliary, Propulsion, Hull, Electrical or Transportation, and a most likely time period for repair, the system failures provided by NSWCCD Little Creek were arranged by system type, and their respective maintenance times were computed by triangular distribution (i.e., least, greatest and most likely) using a Microsoft EXCEL statistical analysis tool kit. With regard to the 12.34 hours spent on repairing a SURC Trailer

Assembly (Table 33), it is important to note that new all-terrain boat trailers are currently being shipped to Riverine Squadron One, and according to the RIVGRU Materiel Officer, the RF expects significant improvements regarding the number of transportation related failures.³⁷⁴ As with any new system, there is a possibility of increased failure reporting at its inception. Commonly referred to as the “bath tub curve,” Figure 104 “illustrates certain relative relationships. Actually, the curve may vary considerably depending on the type of system and its operational profile. Further, if the system is continually being modified for one reason or another, the failure rate may not be constant.”³⁷⁵

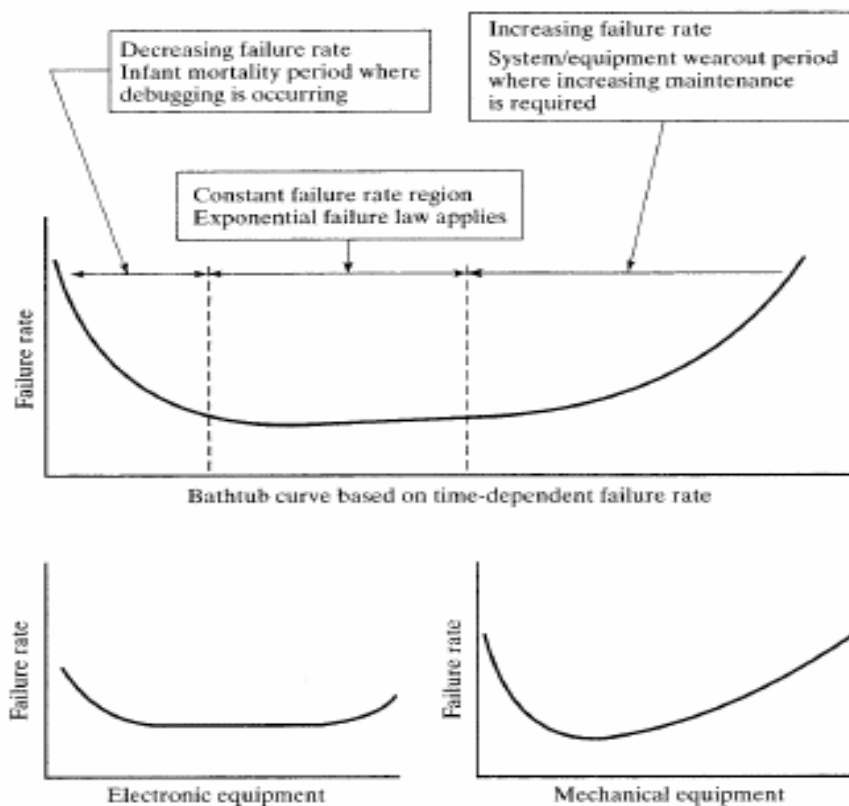

Figure 104. Typical failure-rate curve relationships

This diagram has particular relevance to new electronics equipment such as Blue Force Tracker (BFT) and Forward Looking Infrared (FLIR) systems, which will be installed on all SURC’s for use by 2012. These modifications are expected to have a significant impact on the RF maintenance function in terms of skill set allocation (e.g.,

too many mechanics and not enough electronics technicians) in order to maintain desired levels of operational availability.

With regard to contractor scheduled maintenance, “The SURC and Riverine Assault Craft are a maintenance intensive watercraft...we must conduct maintenance on these craft weekly by trailering the watercraft and allowing our Raytheon Field Service Representative to conduct scheduled maintenance to ensure optimal performance. (Recommendation) weekly 24 hour stand down back to riverine launch/recover site in a secure area where our Field Service Representative can conduct scheduled maintenance.”³⁷⁶ Typical maintenance activities of the field representative are described in Table 34.

CONTRACTOR SCHEDULED SERVICE	Periodicity
TRANSMISSION 500-HOUR SERVICE	
Check flexible coupling & mounting pads	500 hrs
Inspect Clutch Disc for cracks & wear	500 hrs
Inspect Gears for wear	500 hrs
Check indicators for accuracy	500 hrs
Clean Oil Cooler	500 hrs
Replace Zinc Anode	500 hrs
Replace Suction Filter	3000 hrs
ENGINE ADJUSTMENTS	
Adjust injection press. & Atomizer	250/1000 hrs
Adjust clearance intake/exhaust	250/1000 hrs
ENGINE MINI-OVERHAUL	
Clean engine lube oil cooler	2000 hrs
Replace engine impeller	2000 hrs
Clean engine sea water system	2000 hrs
Clean engine fresh water system	2000 hrs
Adjust of injector timing	2000 hrs
Overhaul fuel feed pump	2000 hrs
Lap the intake & exhaust valves	2000 hrs

Table 34. SURC Maintenance and Service Plan Excerpt³⁷⁷

The RST did not, however, include a specific contractor maintenance function in the model and constrained the model to reflect only the maintenance that the RF personnel would be responsible for during the scenario. As discussed earlier, the RST’s

intention was to depict the positive impact that additional maintenance personnel would have on the SURC operational availability. It is assumed that additional maintainers with increased skill sets will perform certain contractor duties thereby decreasing the RF's dependency on contractor maintenance within the scenario.

5.3.2 Data Outputs

The EXTEND simulation was based upon a 180-day period, or 4320 hours, where the SURC's were placed into an operational schedule that varied engine operating hours from 8.5 to 9.5 hours per mission. The scheduling function of the model required that no less than 4 SURC's would be sent on patrol at any given time. Each SURC was assigned an attribute of "operating hours" as well as a particular watch section, as to allow the model to be able to track the operating hours and status (i.e., on patrol, in maintenance, waiting in queue) of each SURC. Both corrective and preventive maintenance (CM and PM, respectively) were highly dependent upon operating hours as. Each SURC met the criteria for CM by reaching a specified amount of operating hours. In this model, the RST chose to use a MTBF of 108 hours, derived from Table 35, as the manufacturer's MTBF from a recent FRACAS report was on an order of magnitude to high for the purposes of this study, and only included Mission Critical failures.³⁷⁸

Craft	Craft Hours (Port)	Craft Hours (Stbd)	OPHRS	FAILURES			MISSION MTBF (F1)	MISSION (F1)
				F1	F2	F3		
1	228.9	231.8	231.8	0	0	0	N/A	1.000
2	274.1	285.1	285.1	1	1	2	285	0.959
3	322.0	309.0	322.0	1	4	0	322	0.963
4	1148.0	1149.0	1149.0	1	1	5	1149	0.990
5	687.0	268.0	687.0	2	17	1	344	0.966
6	760.8	759.9	760.8	1	8	12	761	0.984
7	570.0	650.0	650.0	2	22	4	325	0.964
8	990.0	1145.0	1145.0	2	6	2	573	0.979
9	960.0	1233.0	1233.0	5	15	6	247	0.953
10	516.1	571.3	571.3	0	2	0	N/A	1.000
11	794.0	778.0	794.0	0	9	3	N/A	1.000
12	725.0	263.0	725.0	5	18	10	145	0.921
13	721.0	760.0	760.0	2	9	2	380	0.969
14	296.0	639.0	639.0	1	12	3	639	0.981
15	536.0	529.0	536.0	0	7	4	N/A	1.000
16	474.0	462.0	474.0	1	4	1	474	0.975
17	551.0	547.0	551.0	1	6	6	551	0.978
18	Unk	Unk	97.0	1	5	6	97	0.884
19	501.0	504.0	504.0	0	18	9	N/A	1.000
20	397.0	388.0	397.0	1	12	6	397	0.970
Total			12512.0	27	176	82	463	0.974

Table 35. SURC Reliability³⁷⁹

From Table 35, the Repair Group used only F1 failures, those failures which were mission critical and require immediate repair, and F2 failures, major failures that could lead to mission critical failures and require repair prior to subsequent missions. A key assumption in this model was that only half of the F2 failures were considered to be potential mission critical failures. For the purposes of this study, MTBF was defined as

Operating Hours divided by the sum of the F1 and F2 failures. More assumptions and limitations of this model are discussed later in this chapter.

The CM function of the model was enabled when a SURC met the required number of operating hours and was then assigned a particular type of fault. In this case, the distribution of failures followed the trend of faults listed in the August 2006 SURC RMA report, referred to earlier in this chapter.³⁸⁰ While in the CM loop, the fault would be assigned a repair time based upon a triangular distribution of highest, lowest and most likely. For example, 50% of all failures were propulsion related. When this occurred, it required a minimum of 1 hour to repair, a maximum of 9.25 hours, and a most likely repair time of 5.32 hours. These repair times were derived from a recent SURC failure report, and the methodology was applied to all five fault categories (i.e., propulsion, electrical, auxiliary, hull and transportation).³⁸¹ The PM function followed a similar scheme; however, it was broken down into specific types of periodic maintenance, rather than particular failures. Both the CM and PM functions required particular resources, which this model allowed the RST to modify in accordance with our alternatives and research data. Key data outputs included total CM and PM time, total CM and PM actions, MCMT, MPMT, Operational Availability, Average Number of SURC's available within the RST scenario, and resource utilization. The varying the number of personnel, maintenance bays, and SURC's showed that a baseline of 9 personnel (given a 12-hour shifts), two maintenance bays and 12 SURC's could produce an A_o of ~90%. The Mean Corrective Maintenance and Mean Preventive Maintenance Times varied slightly between alternatives; however the model's configuration made the A_o figure particularly susceptible to changes in MSRT.

5.3.3 Software Processes, Assumptions and Limitations

Key assumptions included the RST's assignment of resources with regard to CM and PM. For example, the RST model allowed for 80% of the propulsion faults to be repaired dockside, while twenty percent of the propulsion faults required a maintenance bay. Further research into the work break down structure of CM and PM actions within the RF, especially considering electronics maintenance in a riverine environment during the rainy season, should be of added value to this model. Another assumption of this model was that there was no need to for special tools and that all repair parts were available at the FOB. Furthermore, the maintenance personnel were not responsible for any PM below the monthly level (i.e., bi-weekly, weekly, or daily); as such checks were assumed to be completed by the boat crews. With regard to rolling gear and transportation equipment, the RST assumed that number of trucks and trailers would be minimal, considering the physical layout of the FOB and the requirement for a small footprint within the RST scenario. For this reason, rolling gear maintenance hours were restricted only to CM associated with trailers, without any accounting of PM for rolling gear. The RST also discounted administrative delays with the RF maintenance system as inconsequential; as such delays do not significantly affect the operational availability figures.

5.4 FORCE PROTECTION GROUP

5.4.1 Software

The RST used the Map-Aware Non-Uniform Automata (MANA) combat model and MATLAB to analyze the various architectures of the FPS against the different threats.

5.4.1.1 MANA

MANA was selected as a choice in modeling due to its high fidelity and the nature of this study as a follow on to SEA-10. MANA is an agent based simulation (ABS), meaning that each entity in the simulation is controlled by decision making algorithms, instead of specific behaviors dictated by the programmer.³⁸² The primary

advantage of MANA over larger physics based programs is the detail and high fidelity of MANA.³⁸³ “MANA and similar programs are often called complex adaptive systems (CAS) because of the way the entities within them react to their surroundings. There are some common properties associated with MANA and CAS combat models. The first is that the “global” behavior of the system emerges as the result of many local interactions. The second is that CAS is an example of a process of feedback that is not present in “reductionist”, top-down models. The third is that CAS cannot be analysed by decomposition into simple independent parts. And finally, the fourth common property is that Agents interact with each other in non-linear ways, and “adapt” to their local environment.

The MANA model was an attempt to create a complex adaptive system for important real-world factors of combat such as: spontaneous change of plans due to the evolving battle conditions, the influence of situational awareness on units when deciding on a course of action,³⁸⁴ and the importance of sensors and how to use them to best advantage.³⁸⁵

5.4.1.2 MATLAB

In addition to MANA, the RST used MATLAB to analyze the effects of specific components on the immediate perimeter of the FOB. “MATLAB is a high-level technical computing language and interactive environment for algorithm development, data visualization, data analysis, and numeric computation.”³⁸⁶ The model constructed by the RST used mathematical analysis with Markovian Chains and a Monte Carlo Simulation. More of the specifics of the mathematical model is discussed further in the software set-up for the MATLAB simulation.

5.4.2 MANA Software Setup

The MANA software was set-up to model the specific architectures for the specific threats. There were four different scenarios modeled according to the architectures developed in chapter 4 for the FPS. The first scenario was a mortar attack on the FOB. The second scenario modeled the commando raid on the FOB. The third

scenario modeled the boat attack on the FOB, and the fourth scenario modeled the boat attack on the MOB.

5.4.3 Scenario 1: Mortar Attack on the FOB

In this scenario the Blue force was required to defend against Red insurgents firing 82mm mortars. The Red mortar team was modelled as a single man unit capable of carrying 15 rounds and a mortar through the use of a slow moving form of transportation, such as a horse or cow cart. The Red mortar personnel were disguised as civilians until reaching a certain point at which they set up the mortar within 2 minutes, aim, and fire at the operating base as quickly as possible (approximately 10 rounds/minute). After firing, the Red mortar abandoned the weapon and attempted to make a quick exit. The Red mortar had an effective range of 6 km and accurate knowledge and means to aim at the FOB through previously gathered intelligence.

The accuracy of the Red mortar unit could be affected by many factors such as the accuracy of the intelligence, crew proficiency, accuracy of the weapon and projectile, and size of the intended target. These inaccuracies were ignored, which enabled the Red mortar team to strike at the target with every shot, making this a worst case scenario. Figure 105 is a basic diagram of the approaching attack on the FOB.

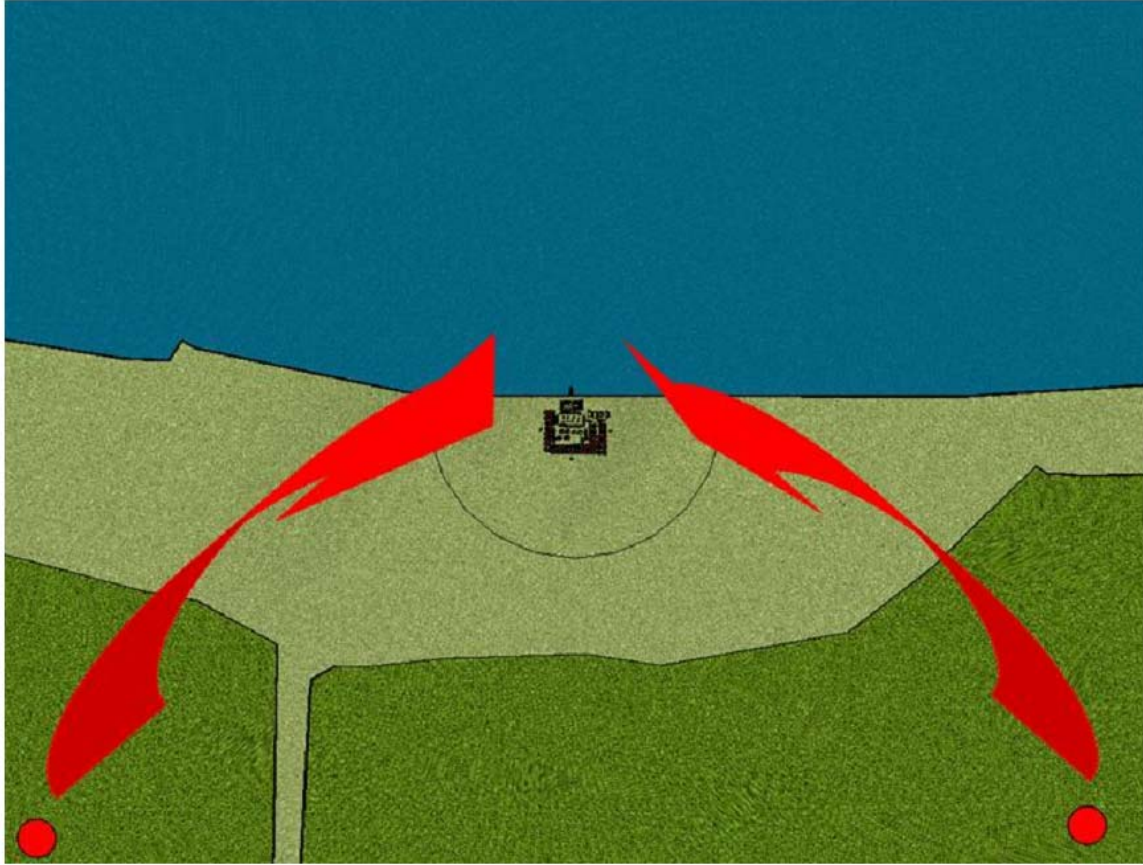

Figure 105. Mortar Attack Diagram

The terrain surrounding the base was assumed to be flat, but incredibly wet and muddy. This made the use of trucks, such as HMWWVs, impractical as they would get bogged down. The assumption was made that the baseline force protection would only be used for peripheral defense.

In this scenario, 5 Blue defense options would be evaluated against the threat to examine their limitations and effectiveness:

- a. Baseline base defense without any capability to detect and counter mortar unit
- b. Baseline base defense with UAV and mortar fire support
- c. Baseline base defense with counter-fire radar, mortar fire support
- d. Baseline base defense with counter-fire radar, mortar fire support and UAV

The parameters to evaluate effectiveness included: the numbers of Red mortar rounds striking the Blue unit and the numbers and the time of Red Mortar unit casualties.

5.4.3.1 Scenario 1A: Mortar Defense (baseline defense)

Table 36 describes the entities and their setup used in this scenario.

Scenario 1A Setup				
	Weapons	Moving Speed	Identify Range	Agent States
Blue Force				
Blue TOC				Default- Recorded hits from Red Mortar unit
Red Force				
Red Mortar unit	82mm mortar (primary) Max target/step: 16/100 (4 rds /min). Max effective range: 4km High Explosive (Hit rate): 1 at 0m and 1 at 6.56m from impact point Setup mortar: 1 minutes Rounds (per unit): 15 AK-74 5.45mm Assault Rifle (Secondary) Max target/step: 200/100 (3 sec/target) Accuracy: 0.5 at 500 m max effective range	1km/hr (on to deployment site); 2 km/hr (on retreat)	The unit visual classify range was set at 748m In order to identify and able to fire at Blue target, the unit was linked through inorganic situation awareness (SA) to a virtual "RED REF SEN" unit placed beside Blue target.	Default- Allegiance was set to 0 as a neutral unit and unarmed (disguise as civilian). In this state the agent was safe from Blue agent.
				Reach Final Waypoint – Allegiance was set to 2 and threat level 2. At this point a delay was set at 25 steps (1min) where Red unit was armed with only AK-74 rifle as the mortar was deployed. In this state Red unit was safe from Blue Mortar counter fire via Counter-fire Radar Detection, but not if they were visually detected by Blue patrol units or UAV that can call for Blue Mortar fire or fired it's own weapon if armed.
				Spare 1 –The mortar was armed and waiting for the unit to target and fire the first round at Blue unit target (Blue TOC or Mortar).
				Taken Shot (Pri) –The first round was fired off but the threat level remains at 2 for 10 steps (24sec) to signify minimum time for counter-fire radar (if deployed) to compute Red mortar locations. (Blue mortar unit was only able to return fire on Red mortar
				Spare 3 – The threat level was set to 1 where the Red mortar unit was now vulnerable to Blue Mortar unit counter fire and any approaching Blue unit.
				Ammo Out Wpn 2 – Red unit depleted their mortar rounds, abandoned the mortar, and head to the alternative way point. Threat level remains as 1 for a duration 20 steps (48 sec) as the Red unit was still in a region vulnerable to Blue Counter–fire Radar.
				Spare 2 – The threat level was set to 2. Now Red mortar firer was safe from Blue Counter Battery Fire.

Table 36. Scenario 1A Setup

This scenario only consisted of the Red Mortar unit firing at the Blue TOC with the described states and weaponry of Table 36. The Red Mortar unit possessed no armor and only took one hit to kill, while the Blue TOC took infinite hits to record how many hits struck the base.

5.4.3.2 Scenario 1B: MORTAR DEFENSE (with UAV and mortar fire support)

Table 37 describes the entities and their setup used in this scenario.

Scenario 1B Setup				
	Weapons	Moving Speed	Identify Range	Agent States
Blue Force				
Blue Mortar	120mm mortar (Engage 10 different targets/min) Max target/step: 20/100 (5 rds /min). Max effective range: 8200m High Explosive (Hit rate): 1 at 0m; 0.5 at 60m from impact		0 8.2 km (UAV integrated for fire control)	Default- Recorded hits from Red Mortar unit and did not fire until fired upon and given Red Mortar location through inorganic SA provided by the UAV. There were delays in the time to direct counter fire from the states built into the Red mortar unit.
Blue UAV	None	100km/hr	1.3km	Default- Flies patrol route.
				Squad Situational Awareness of Enemy contact – used to enable the UAV to loiter around any detected Neutral, in this case when Red Mortar unit was moving towards the firing point, the UAV was able to track it.
Red Force				
Same as Scenario 1A				

Table 37. Scenario 1B Setup

In this scenario, The Blue Mortar unit also functioned as the TOC from Scenario 1A in that it recorded the number of hits. The Blue Mortar used the inorganic situational awareness provided by the UAV to locate the Red Mortar Unit. The Blue Mortar unit fired on the Red Mortar Unit when the Red Unit changed their threat level. It was assumed the Red Mortar Unit would not fire on the UAV in this scenario.

5.4.3.3 Scenario 1C: MORTAR DEFENSE (with counter-fire radar, mortar fire support)

Table 38 describes the entities and their setup used in this scenario.

Scenario 1C Setup				
	Weapons	Moving Speed	Identify Range	Agent States
Blue Force				
Blue Mortar with integrated Counter-fire radar	120mm mortar (Engage 10 different targets/min) Max target/step: 20/100 (5 rds /min). Max effective range: 8200m High Explosive (Hit rate): 1 at 0m; 0.5 at 60m from impact	0	8.2 km (counter-fire radar was integrated into the mortar)	Default- Recorded hits from Red Mortar unit and did not fire until fired upon. The enemy location was provided through the counter-fire radar that was integrated into the mortar. There were delays in the time to direct counter fire from the states built into the Red mortar unit.
Red Force				
Same as Scenario 1A				

Table 38. Scenario 1C Setup

In this scenario, the Blue Mortar unit was integrated with the counter-fire radar and depended on the Red mortar team to fire first, before locating their target. The Blue Mortar would fire on the Red Mortar unit when their threat level was changed in coordination with the Red Mortar unit’s agent states from scenario 1A.

5.4.3.4 Scenario 1D: MORTAR DEFENSE (with counter-fire ground radar, mortar fire support and UAV)

Table 39 describes the entities and their setup used in this scenario. In this scenario, the Blue Mortar with integrated Counter-fire radar was further integrated with the UAV to provide continuous coverage of the attacking Red Mortar unit.

Scenario 1D Setup				
	Weapons	Moving Speed	Identify Range	Agent States
Blue Force				
Blue Mortar with integrated Counter-fire radar	120mm mortar (Engage 10 different targets/min) Max target/step: 20/100 (5 rds /min). Max effective range: 8200m High Explosive (Hit rate): 1 at 0m; 0.5 at 60m from impact	0	8.2 km (counter-fire radar was integrated into the mortar)	Default- Recorded hits from Red Mortar unit and did not fire until fired upon. The enemy location was provided through the counter-fire radar that was integrated into the mortar. There were delays in the time to direct counter fire from the states built into the Red mortar unit.
Blue UAV	None	100km/hr	1.3km	Default- Flies patrol route.
				Squad Situational Awareness of Enemy contact – used to enable the UAV to loiter around any detected Neutral, in this case when Red Mortar unit was moving towards the firing point, the UAV was able to track it.
Red Force				
Same as Scenario 1A				

Table 39. Scenario 1D Setup

5.4.4 Scenario 2: Ground RAID ON FOB

In this scenario Blue force was required to defend against a huge number of Red insurgents (100units) carrying RPGs and rifles. The scenario was modelled as night with very low visibility. The Blue unit was aided by night vision giving them the further detection range than the Red unit. The Red unit, on the other hand, had intelligence of Blue unit patrol position and location of Blue unit firing post as well as lighting from the Blue base giving aid in direction.

The Red had the advantage of numbers and when the Blue unit fired they revealed their location for counter fire by Red units. A Red unit objective was to penetrate into the Blue FOB and reach the base centre where they could detonate their bombs. Red unit's strategy was to concentrate their numbers on one gun post and try to avoid the Blue Patrol unit. Figure 106 is a basic diagram of the raid.

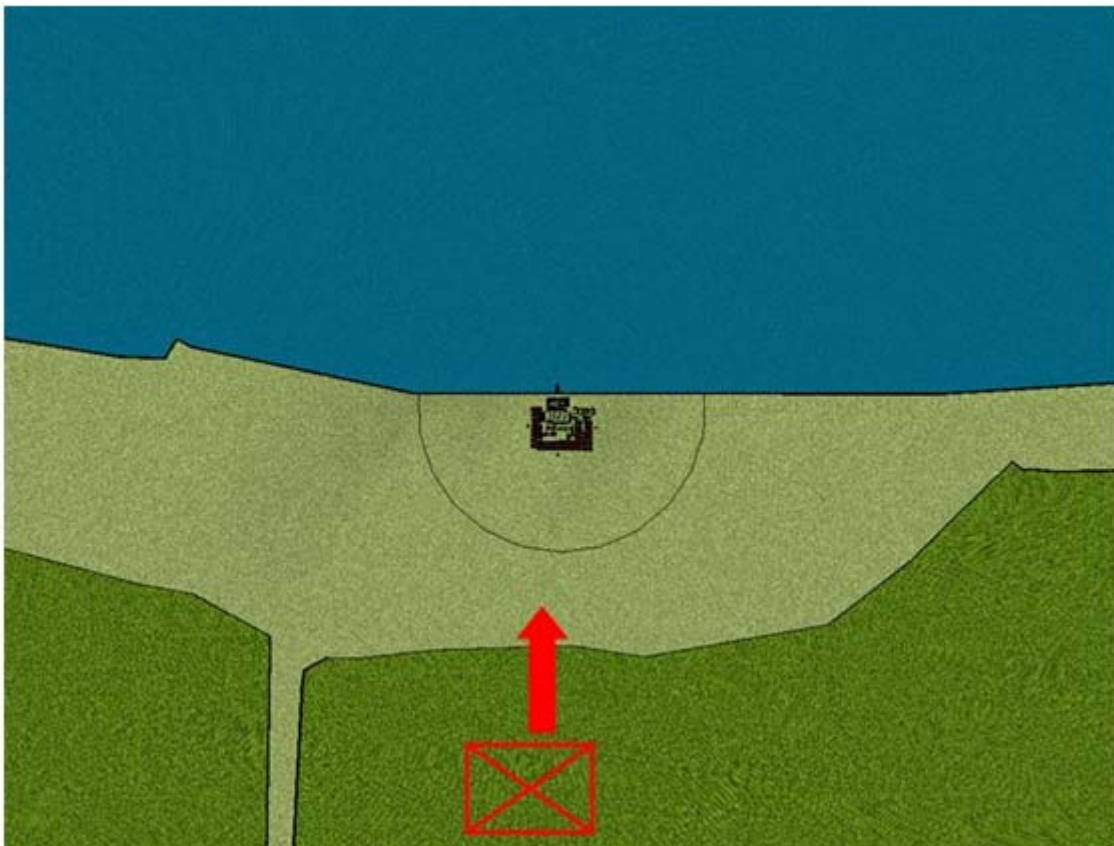

Figure 106. Raid on FOB Diagram

In this scenario, 3 Blue defense options would be evaluated against the threat to examine their limitations and effectiveness:

- a. Baseline base defense.
- b. Baseline with sensor fence and 120mm mortar support.
- c. Baseline base defense with 120mm mortar and ROSAM support.

The parameters to evaluate effectiveness included: number of Blue units killed, number and time of Red unit casualties, and number of successful Red infiltrations.

5.4.4.1 Scenario 2A: GROUND RAID ON FOB (baseline security)

Table 40 describes the entities and their setup used in this scenario.

Scenario 2A Setup				
	Weapons	Moving Speed	Identify Range	Agent States
Blue Force				
Blue Gun Post (6 units)	M2 .50 cal machine guns. Max target/step: 1200/100 (0.5 sec/target). (Since two man operate a single M2 gun in each post, each man was given a 600/100 max target/step setting) Accuracy: 0.5 at 1830 m max effective range	0	150m	Default- Recorded hits from Red Mortar unit and did not fire until fired upon. The enemy location was provided through the counter-fire radar that was integrated into the mortar. There were delays in the time to direct counter fire from the states built into the Red mortar unit.
Blue Patrol (4 units)	M249 5.56mm heavy machine gun (Primary) Max target/step: 600/100 (1 sec/target) Accuracy: 0.5 at 1000 m from aim point M16 A2/A3 5.56mm Assault Rifle (secondary) Max target/step: 300/100 (2 sec/target) Accuracy: 0.5 at 550 m from aim point M203 40mm grenade launcher (secondary) Max target/step: 50/100 (5 rds/min) Accuracy: 0.5 at 200 m from aim point	1 km/hr for default state 2 km/hr for the different agent state	150m	Default- Standard patrol across perimeter defenses at 1 km/hr. Inorganic Situational Awareness Enemy contact- Patrol Speed increased to 2 km/hr to reached detected enemy unit by other Blue agent.
Blue Personnel (20 units)	M16 A2/A3 5.56mm Assault Rifle (secondary) Max target/step: 300/100 (2 sec/target) Accuracy: 0.5 at 550 m from aim point M203 40mm grenade launcher (secondary) Max target/step: 50/100 (5 rds/min) Accuracy: 0.5 at 200 m from aim point	0 km/hr for default state 1 km/hr for the different agent state	150m	Default- performing day to day operations, not moving Inorganic Situational Awareness Enemy Contact 1 – when Red units were detected, Blue personnel would walk towards the waypoint where they can shoot at Red units penetrating the perimeter.
Red Force				
Red Rifle (50 units)	RPK-74 5.45 Light machine gun (Primary) Max target/step: 300/100 (2 sec/target) Accuracy: 0.5 at 800 m max effective range	1 km/hr approaching the base 2 km/hr when fired upon and inside the base	100m outside of the base, 145 inside the base perimeter	Default- Approaching the base.
	AK-47 7.62mm Assault Rifle (Primary) Max target/step: 200/100 (3 sec/target) Accuracy: 0.5 at 300 m max effective range			Squad Situational Awareness Enemy Contact 1- when someone in the squad detected a Blue agent, the entire squad would engage the Blue agent.
				Shot At (Pri/Sec) – when Blue forces opened fire, Red agents began dashing, thus increasing their speed from 1 km/hr to 2km/hr.
Red RPG-7 (50 units)	RPG-7 Launcher (Primary) Max target/step: 60/100 (6 rounds/min) Accuracy: 0.8 at 300 m max effective range AK-74 5.45mm Assault Rifle (Primary) Max target/step: 200/100 (3 sec/target) Accuracy: 0.5 at 500 m max effective range	1 km/hr approaching the base 2 km/hr when fired upon and inside the base	100m outside of the base, 145 inside the base perimeter	Default- Approaching the base. Squad Situational Awareness Enemy Contact 1- when someone in the squad detected a Blue agent, the entire squad would engage the Blue agent.

Table 40. Scenario 2A Setup

The Blue Gun Posts were a part of the first layer of base security defense ensuring no enemy units could penetrate the peripheral of the base. Each gun post employed required a two man team. A total of 8 gun posts surrounded the FOB, but 6 were used in this scenario because two of the gun posts were in a position along the river where they could not be used against a raid on land. The Blue gun posts were assumed to require two hits to kill and had an armour of 10 mm. The Blue patrol were also a part of

the first layer of security and roamed from post to post. They also were given two hits to kill.

The Blue personnel represented all other personnel within the base that were not necessarily a part of perimeter personnel (eg. the resting security team, mechanics, cooks etc) that could be deployed in times of emergency to perform the base defense role when the base security was overwhelmed by a large number of Red insurgent units. In this scenario the Blue personnel were activated when huge numbers of Red attacking units were detected by Blue gun post or patrol unit. The Blue Personnel would position themselves within range to fire at Red unit penetrating the fence.

The Red insurgents carried rifle and machine guns without any navigation aid, but with intelligence information on Blue gun post positions and visual information based on lightings surround Blue FOB. It was assumed that all of the Red Forces in this scenario would only require one hit to kill.

5.4.4.2 Scenario 2B: GROUND RAID ON FOB (with Sensor fence and Mortar)

Table 41 describes the entities and their setup used in this scenario.

Scenario 2B Setup				
	Weapons	Moving Speed	Identify Range	Agent States
Blue Force				
Same as Scenario 2A with additional				
Blue Mortar	120mm mortar (Engage 10 different targets/min) Max target/step: 20/100 (5 rds /min). Max effective range: 8200m High Explosive (Hit rate): 1 at 0m; 0.5 at 60m from impact		0 8.2 km (integrated with Sensor Fence and Blue Forces for fire support)	Default- waited until directed to fire.
Sensor Fence	None		0 32 meters	Default- sits stationary and detects and sends contact identification to other Blue forces and Blue Mortar
Red Force				
Same as Scenario 2A				

Table 41. Scenario 2B Setup

In addition to the forces in the previous scenario, the Blue Force added the Sensor Fence and the Mortar unit. The Sensor Fence was setup to deter and slow down

Red insurgents penetrating the perimeters. The Mortar unit was linked to Sensor Fence and all Blue units to provide additional artillery support against the attacking Reds.

5.4.4.3 Scenario 2C: GROUND RAID ON FOB (with remote turret)

Table 42 describes the entities and their setup used in this scenario.

Scenario 2C Setup				
	Weapons	Moving Speed	Identify Range	Agent States
Blue Force				
Same as Scenario 2A with additional				
ROSAM (6 units)	M2 .50 cal machine guns. Max target/step: 1200/100 (0.5 sec/target). (Since two man operate a single M2 gun in each post, each man was given a 600/100 max target/step setting) Accuracy: 0.5 at 1830 m max effective range		150m	Default- Stationary and ready to fire upon identifying an enemy.
Red Force				
Same as Scenario 2A				

Table 42. Scenario 2C Setup

In this scenario, the ROSAM weapon stations replaced the gun posts and were assumed to have the same ranges of detection. The armour was increased to 50mm with five hits to kill.

5.4.5 Scenario 3: BOAT ATTACK ON FOB

In this scenario the Blue force were required to defend against a number of Red insurgents in motor boats (12 attacking boats) disguised as civilian crafts carrying hidden RPGs and rifles. The scenario was modelled under clear day visibility, as this time of day would likely have more traffic and make it easier for the insurgents to blend in. The main target for the Red insurgents was the moored SURC’s. Figure 107 is a diagram of the attack.

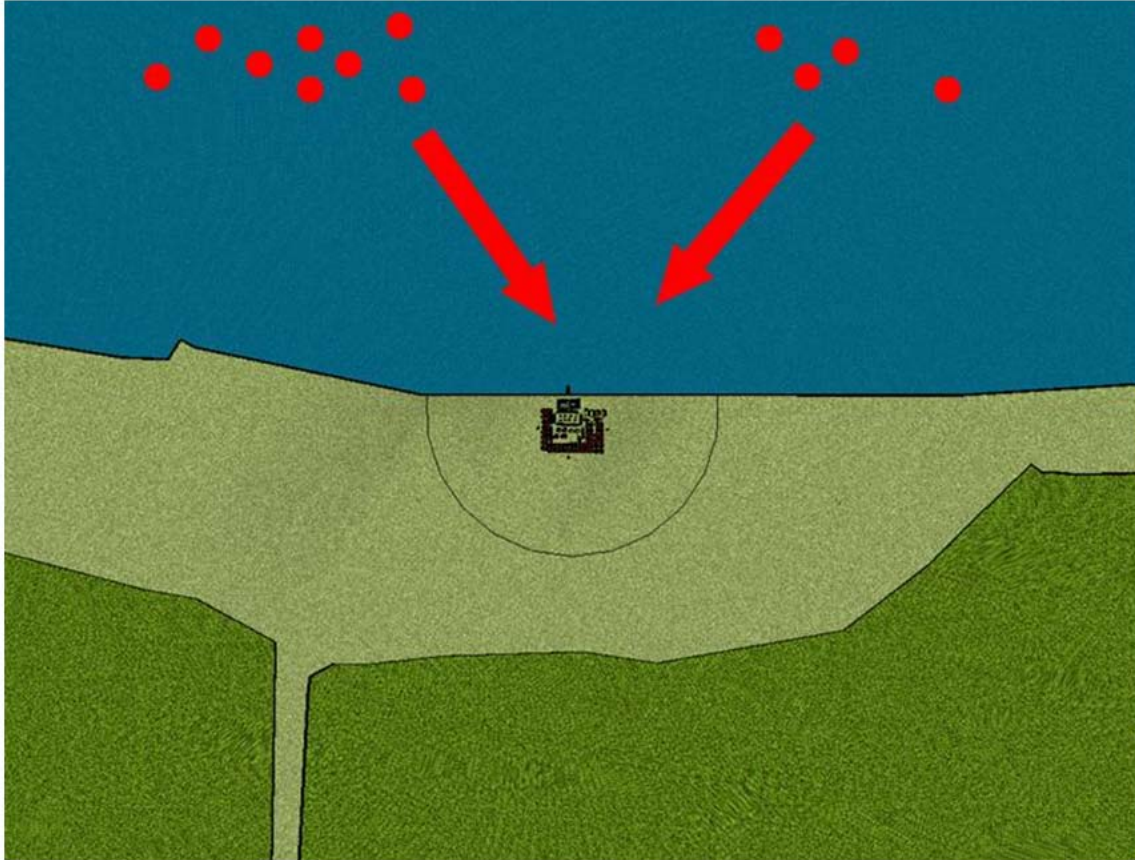

Figure 107. Boat Attack on FOB Diagram

In this scenario, four Blue defensive alternatives would be evaluated against the threat to examine their limitations and effectiveness:

- a. Baseline base defense
- b. Baseline base defense with floating barrier
- c. Baseline base defense with floating barrier and ROSAM
- d. Baseline base defense with floating barrier and ROSAM and USV

The parameters used to evaluate effectiveness included the location of Red casualties, the number of hits on Blue Gun Post/ ROSAM, and the number of destroyed SURC's.

5.4.5.1 Scenario 3A: BOAT ATTACK ON FOB (baseline defense)

Table 43 describes the entities and their setup used in this scenario.

Scenario 3A Setup				
	Weapons	Moving Speed	Identify Range	Agent States
Blue Force				
Blue Gun Post (4 units)	M2 .50 cal machine guns. Max target/step: 480/100 (0.5 sec/target). (Since two man operate a single M2 gun in each post, each man was given a 240/100 max target/step setting) Accuracy: 0.5 at 1830 m max effective range	0	746m	Default- Stationary and ready to fire upon identifying an enemy.
Blue Moored SURCs (4 units)		0	0	Default State- the SURCs are not occupied and moored
Red Force				
Red Boat RPG-7 Type 1 (8 units)	RPG-7 Launcher (Primary) Max target/step: 24/100 (6 rounds/min) Accuracy: 0.8 at 300 m max effective range AK-74 5.45mm Assault Rifle (Primary) Max target/step: 80/100 (3 sec/target) Accuracy: 0.5 at 500 m max effective range	12.5 km/hr for blending in with traffic to 25 km/hr on attack	746m	Squad Situational Awareness of an Enemy contact 1 & Taken Shot (Pri/Sec) – when Red units encounter approaching Blue or when they reached the way point they open fire.
			746m	Squad Situational Awareness of an Enemy contact 1 & Taken Shot (Pri/Sec) – when Red units encounter approaching Blue or when they reached the way point they open fire.
Red Boat RPG-7 Type 2 (4 units)	RPG-7 Launcher (Primary) Max target/step: 24/100 (6 rounds/min) Accuracy: 0.8 at 300 m max effective range AK-74 5.45mm Assault Rifle (Primary) Max target/step: 80/100 (3 sec/target) Accuracy: 0.5 at 500 m max effective range	12.5 km/hr for blending in with traffic to 25 km/hr on attack	746m	Squad Situational Awareness of an Enemy contact 1 & Taken Shot (Pri/Sec) – when Red units encounter approaching Blue or when they reached the way point they open fire.
			746m	Squad Situational Awareness of an Enemy contact 1 & Taken Shot (Pri/Sec) – when Red units encounter approaching Blue or when they reached the way point they open fire.

Table 43. Scenario 3A Setup

For this scenario, the same gun posts used for Scenario 2A are placed along the river. There are only four gun posts against an attacking force of 12 Red boats carrying RPGs. Eight of the boats, RPG-7 Type 1, attack initially and are followed shortly after by four more boats.

5.4.5.2 Scenario 3B: BOAT ATTACK ON FOB (baseline defense and floating barrier)

In this scenario, a floating barrier was added that did not have any interactions in the scenario other than take away line of sight from the enemy boats to the moored SURC's. The barriers also made the enemy boats travel snake through the barrier instead of charging directly at the moored SURC'S.

5.4.5.3 Scenario 3C: BOAT ATTACK ON FOB (floating barrier and ROSAM)

Table 44 describes the entities and their setup used in this scenario.

Scenario 3C Setup				
	Weapons	Moving Speed	Identify Range	Agent States
Blue Force				
Same as Scenario 3B with additional				
ROSAM (4 units, replaced the 4 Gun posts)	M2HB .50 cal machine guns. Max target/step: 480/100 (0.5 sec/target). Accuracy: 0.5 at 1830 m max effective range		0 746m	Default- Stationary and ready to fire upon identifying an enemy.
Red Force				
Same as Scenario 3A				

Table 44. Scenario 3C Setup

In this scenario, the ROSAMs replaced the Blue Gun Posts of Scenario 3A. They offered the same amount of armament and hits to kill as they did in Scenario 2C.

5.4.5.4 Scenario 3D: BOAT ATTACK ON FOB (with baseline defense, floating barrier, and patrol boat)

Table 45 describes the entities and their setup used in this scenario. This scenario was the same as Scenario 3B with the addition of a PB. The PB conducted a patrol around the base of operations and approached any suspicious units moving towards the FOB into the restricted zone. The purpose of the PB was to deter any attack and to identify threat early to give more time for engagement. The PB took 15 hits to kill as it was manned by a crew of three and had armor.

Scenario 3D Setup				
	Weapons	Moving Speed	Identify Range	Agent States
Blue Force				
Same as Scenario 3B				
Patrol Boat	M2HB .50 cal machine guns. Max target/step: 480/100 (0.5 sec/target). Accuracy: 0.5 at 1830 m max effective range	25 km/hr	746m	Default- Conducting programmed patrol.
				Squad Situational Awareness of an Enemy contact 1 & Taken Shot (Pri/Sec) – when the PB identify a Red boat they open fire.
Red Force				
Same as Scenario 3A				

Table 45. Scenario 3D Setup

5.4.5.5 Scenario 3E: BOAT ATTACK ON FOB (ROSAM, floating barrier, and patrol boat)

This scenario was the same as Scenario 3C, with the PB that was used in Scenario 3D. The ROSAMs coordinated with the PB to fire on the enemy in the same fashion as the manned gun posts.

5.4.6 Scenario 4: BOAT ATTACK ON MOB

In this scenario the Blue MOB force was required to defend against a number of Red insurgents in motor boats (12 attacking boats) disguised as civilian crafts carrying hidden RPG's and rifles. The scenario was modeled with good visibility during the day. Two different MOB's were modeled, the RCSS and the Nobriza and Barge configuration. A line of embarkation was assumed to be established around the MOB at 500 meters. Whenever a boat crossed the 450 meter range of the MOB it was assumed to be an enemy. Figure 108 is a diagram of the attack against the MOB.

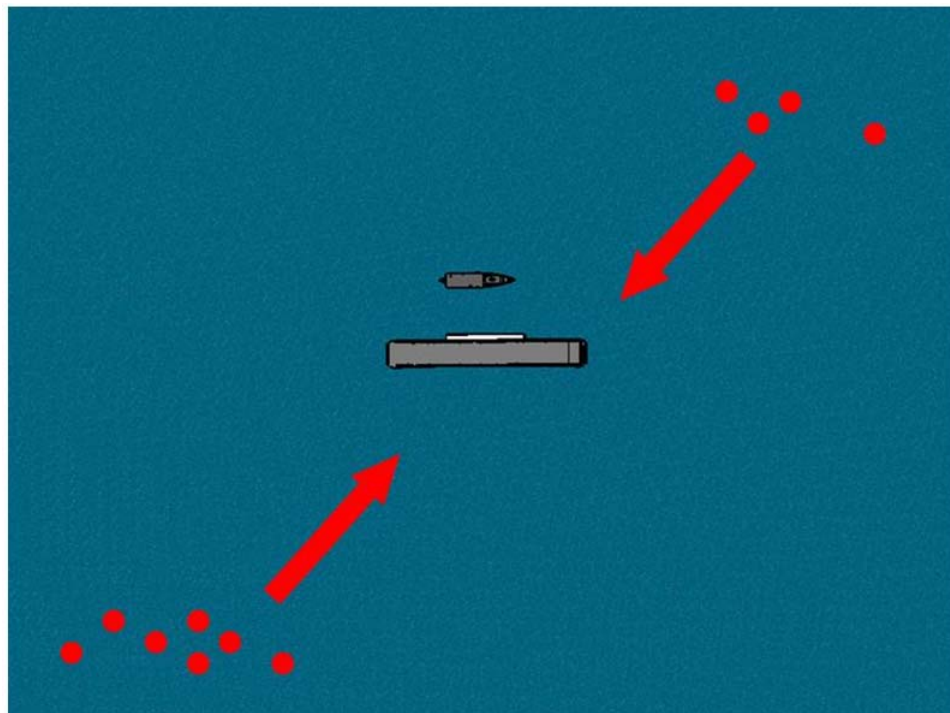

Figure 108. Boat Attack on MOB Diagram

In this scenario, 3 Blue defense options would be evaluated against the threat to examine their limitations and effectiveness:

- a. RCSS baseline.
- b. RCSS baseline with additional patrol boat.
- c. Nobriza and Barge baseline.
- d. Nobriza and Barge with floating barrier and additional patrol boat.

Parameters to evaluate effectiveness include:

- a. Location of Red casualties.
- b. Number of Blue casualties.
- c. Number of SURC's destroyed.

5.4.6.1 Scenario 4A: BOAT ATTACK ON MOB (RCSS Baseline)

Table 46 describes the entities and their setup used in this scenario. The scenario used three red forces to model the RCSS baseline architecture. There was an entity named the MOB which was a focus point of the attack of the Reds along with the moored SURC's. The 25 mm weapon mounts was also added as the offensive firepower for the RCSS. The attacking Red force was the same as in Scenario 3. The weapon mounts were given three hits to kill and an armor of 10 mm.

Scenario 4A Setup				
	Weapons	Moving Speed	Identify Range	Agent States
Blue Force				
MOB (1 unit)	None	None	None	Default-served as a target for the attacking Reds.
Blue moored SURCs (4 units)				Default-served as a target for the attacking Reds.
MOB 25mm Weapon Mount (2 units)	M242 25mm (Mk38 Mod 2) Max target/step: 600/100 (1 sec/target). Accuracy: 0.5 at 2000 m max effective range		1250m	Default- Stationary and ready to fire upon identifying an enemy.
Red Force				
Red Boat RPG-7 Type1 (4 units)	RPG-7 Launcher (Primary) Max target/step: 24/100 (6 rounds/min) Accuracy: 0.8 at 300 m max effective range AK-74 5.45mm Assault Rifle (Primary) Max target/step: 80/100 (3 sec/target) Accuracy: 0.5 at 500 m max effective range		746m	Default – Red was given threat 3 which make it safe from Blue unit. It was set to move away from USV and it's weapon were all turn on against any detected blue units.
				Reached waypoint & Taken Shot (Pri/Sec) – when Red units took a shot at Blue or when they reached the waypoint, red units were identified as a threat to blue unit and their threat level changed to 2, making them vulnerable to Blue fire
Red Boat RPG-7 Type2 (8 units)	RPG-7 Launcher (Primary) Max target/step: 24/100 (6 rounds/min) Accuracy: 0.8 at 300 m max effective range AK-74 5.45mm Assault Rifle (Primary) Max target/step: 80/100 (3 sec/target) Accuracy: 0.5 at 500 m max effective range		32m	Default – Red was given threat 3 which made it safe from Blue unit. It was set to move away from USV and it's weapon were all activated but not turn on against USV
				Enemy Contact 3/ Taken Shot (Pri/Sec) – when Red encountered USV or took a shot at Blue units, the Red units were identified as a threat to Blue unit and their threat level changed to 2, making them vulnerable to Blue fire

Table 46. Scenario 4A Setup

5.4.6.2 Scenario 4B: BOAT ATTACK ON MOB (RCSS baseline with Patrol Boat (PB))

Table 47 describes the entities and their setup used in this scenario. This scenario added a PB to the defenses of the RCSS. The PB performed the same task as in Scenario 3D. The PB conducted a patrol around the base of operations and approached any suspicious units moving towards the MOB into the restricted zone. The PB took 15 hits to kill as it was manned by a crew of three and had armor.

Scenario 4B Setup				
	Weapons	Moving Speed	Identify Range	Agent States
Blue Force				
Same as Scenario 4A with				
Patrol Boat	M2 .50 cal machine guns. Max target/step: 480/100 (0.5 sec/target) Accuracy 0.5 at 1830m max effective range		746m	Default- Conducting programmed patrol.
				Squad Situational Awareness of an Enemy contact 1 & Taken Shot (Pri/Sec) – when the PB identify a Red boat they open fire.
Red Force				
Same as Scenario 4A				

Table 47. Scenario 4B Setup

5.4.6.3 Scenario 4C: BOAT ATTACK ON MOB (Nobriza and Barge baseline)

Table 48 describes the entities and their setup used in this scenario. The RCSS was replaced with the Nobriza and barge MOB for this scenario. The dimension of the barge was assumed to be similar to previous MOB, with a change in weapon mount from the 25 mm cannon to the eight .50 caliber machine guns. The Nobriza functioned almost similar to a PB, but instead was heavily armored and required 50 hits to kill.

Scenario 4C Setup				
	Weapons	Moving Speed	Identify Range	Agent States
Blue Force				
MOB (1 unit)	None	None	None	Default-served as a target for the attacking Reds.
Blue moored SURCs (4 units)				Default-served as a target for the attacking Reds.
Weapon Mounts (8 units)	M2HB .50 cal machine guns. Max target/step: 480/100 (0.5 sec/target). Accuracy: 0.5 at 1830 m (max effective range)		1830m	Squad Situational Awareness of an Enemy contact 1 & Taken Shot (Pri/Sec) – when the PB identifies a Red boat they open fire.
Nobriza (1 units)	2x Twin M2HB .50 cal machine guns. Max target/step: 480/100 (0.5 sec/target). Accuracy: 0.5 at 1830 m (max effective range) 0.8 at 320 m 1x MK19 40mm Grenade MG. Max target/step: 160/100 (40 rds/min). Max effective range: 1500m High Explosive (Hit rate): 1 at 0m;		748m	Default- Conducting programmed patrol.
				Squad Situational Awareness of an Enemy contact 1 & Taken Shot (Pri/Sec) – when the Nobriza identifies a Red boat they open fire.
Red Force				
Same as Scenario				

Table 48. Scenario 4C Setup

5.4.6.4 Scenario 4D: BOAT ATTACK ON MOB (Nobriza and Barge baseline with barrier and PB)

Table 49 describes the entities and their setup used in this scenario. This scenario was the same as Scenario 4C with the addition of a PB and a barrier, similar to the addition that occurred in Scenario 3D. The floating barrier took away the enemy’s line of sight to the SURC and also made the Red forces snake through the barrier to directly assault the SURC’s. The PB served as in addition to the Nobriza and provided forward observation.

Scenario 4D Setup				
	Weapons	Moving Speed	Identify Range	Agent States
Blue Force				
Same as Scenario 4C with				
Patrol Boat	M2 .50 cal machine guns. Max target/step: 480/100 (0.5 sec/target) Accuracy 0.5 at 1830m max effective range		746m	Default- Conducting programmed patrol.
				Squad Situational Awareness of an Enemy contact 1 & Taken Shot (Pri/Sec) – when the PB identify a Red boat they open fire.
Red Force				
Same as Scenario 4A				

Table 49. Scenario 4D Setup

5.4.7 MATLAB

The MANA simulation incorporated tactical issues in our analysis, regarding sensors, personnel, weapons distribution, and barriers. Due to the complexity of MANA, and our inability to control various parameters, the RST decided to construct a basic-concepts stochastic MATLAB simulation, where all variables were fully controlled, and different dependencies were analyzed. Specifically, the RST wanted to know the effect of the number of sensors, number of personnel, machine guns, bunkers, and IR illuminators. All of these affected the probability to win in combat, and the expected number of blue-force personnel that were killed in combat. This information assisted us in deciding on the distribution of sensors, weapons, manpower, and other fighting aids along the immediate perimeter.

5.4.7.1 Method

A mathematical model was constructed and implemented in MATLAB, as a Monte-Carlo simulation of attacks on our FOB. Each run simulated one attack, which ends when one of the sides is annihilated. The simulation was time-based and uses numerical expression rather than event-based because of the complexity of the model and the inability to “predict” detection events in analytical expressions. However, the battle itself was modeled using analytical tools of stochastic processes.

5.4.7.2 Matlab Definitions

Blue force Parameters and variables:

Symbol	Description	Value taken in the simulation
σ	Mean atmospheric attenuation at the sensor's wavelength (8-12 μ m).	2.3Km ⁻¹ (Assuming rain rate of 25mm/h)
N _B	The total number of armed blue force personnel	Variable, 1 to 60
P _{B-k-R h}	The probability that a red-force personnel will be killed given that he was hit by a blue-force weapon (depends on the type of weapon and his body armor)	0.6
BlueErr	standard deviation of the angular error of the blue-force weapon	10 / 40 mrad (With/Without IR illumination)
BlueExpH / W	The average exposed Height / Width of the blue-force personnel body, behind cover	Without Bunker: 0.3m x 0.4m With Bunker: 0.15m x 0.25m Exposed Guards: 1.7m x 0.4m
BlueFireRate	The fire rate of the blue force weapon	MAG – 240 min ⁻¹ Light Weapons – 40 min ⁻¹
T _{Ave-det}	Average time of the blue force's sensors to detect a red force in “staring” mode	0.5 sec
FOV _H (V)	Sensors field of view	Horizontal - 20deg Vertical – 15deg
FOV _{TOT-V}	Total vertical FOV, for each sweep	30deg
ScanRateV	Vertical scan rate of each sensor (vertical “sweep” rate)	Vertical – 10deg/sec
N _{sensors}	Total number of identical IR sensors	Variable, 0-20
N ₅₀	Number of lines needed to detect and recognize a red force	3 lines (“Recognition”)
T _{surprise}	The time it takes to the blue guards to take cover in case of a surprise of the red forces	4 sec
N _{guards}	Number of blue force patrolling guards at any given time, that are exposed during a possible surprise	4
T _{find-red}	Average time to find a red force personnel in the bushes	1 or 2 sec (With / Without illumination)
N _{Min-Det-To-Engage}	Minimal red forces to detect before engaging	5

Red force Parameters and variables:

Symbol	Description	Value taken in the simulation
N_R	The total number of armed red force personnel	Variable, 5-30
$P_{B-k-R h}$	The probability that a red-force personnel will be killed given that he was hit by a blue-force weapon (depends on the type of weapon and his body armor)	M-16: 0.8 MG: 0.95
RedErr	standard deviation of the angular error of the red force weapon	20mrad
RedExpH / W	The average exposed Height / Width of the red-force personnel body	0.4m x 0.4m
RedFireRate	The fire rate of the red force weapon	40 min ⁻¹ (Light Weapons)
RangeToShoot	The range from the blue forces, at which the red forces will not advance anymore and start their attack	200m
InitialRange(i)	Initial distance of red forces from the FOB. Random variables, uniformly distributed between RangeMin and RangeMax.	RangeMin = 400m RangeMax=600m
V	Velocity of the red forces – radial, towards the FOB	2m/s
ΔT	Temperature difference between target and background	6°K
R(i)	Distance of a red force personnel, i, from the blue forces	Variable, changes throughout simulation
PercentVisible	The percentage of the red force personnel's body that's thermal radiation can reach the sensors (The rest is assumed to be covered by vegetation / concealing)	50%

5.4.7.3 Main assumptions

- The battle occurred at night, hence visual detection of the red forces was irrelevant. Initial detection was made only with thermal imagers. Later detection was made either visually or with illuminators.
- Since the blue forces were stationary in their base, they were more easily located and aimed at than the red forces, which were assumed to be well camouflaged in the dark forest. Hence, the shooting error was significantly larger for the blue forces, unless they used IR illuminators. However, the shooting rate and range of the blue forces' weapons could be significantly higher if they used heavier weapons.
- The red forces advanced up to a certain point – RangeToShoot - from which they would start their surprise attack, unless five of them were already detected.
- Combat ended when all blue/red forces were killed.

- There were no “waves” of forces coming into the fight – whoever participated in the battle, arrives right at the beginning of it. The only exception was the exposed guards that may be surprised and fight independently of the other forces, until they join them.
- The sensors on the perimeter of the FOB were thermal sensors. The detection model was based on the ACQUIRE model for thermal detectors.
- Only red forces could surprise the blue forces because red forces initiated the attack and the blue forces were stationary and being surveyed constantly by the red forces. If red forces were detected, they were assumed to notice immediately this detection.
- This model assumed light-weapons for the red forces and light and heavy weapons for the blue forces.
- Blue forces could use IR illuminators, bunkers to shoot from, and always had better body armor.
- Multiple sensors scanned the field of regard such that each sensor received an equal portion of the scene, i.e. the horizontal field of regard is $360^\circ / \text{number of sensors}$, for every thermal imager.

5.4.7.4 MATLAB Model

Step 1: The number of red forces was distributed uniformly between RangeMin and RangeMax. A range $R(i)$ was assigned to each red force personnel, i , $i \in \{1,2,\dots,N_R\}$.

Step 2: Red forces advanced independently, at velocity V. The number of sensors, Nsensors, were scanning the battlefield. Probability of detection, per one timestep, was calculated according to the ACQUIRE model, with a representative thermal sensor for automatic detection, as follows:

$\forall i \in \{1,2,\dots,N_R\}$ (For every Red force personnel)

The thermal contrast between the target and its background, as received in the sensor's optics plane:

$$\mathbf{signal}(i) = \Delta T \cdot \exp(-R(i)/1000 \cdot \sigma)$$

The spatial frequency of the target, as seen by the sensor:

$$f_R(i) = \begin{cases} 1 & \mathbf{signal}(i) < 0.1 \\ 0.75 \cdot \ln[\mathbf{signal}(i)] + 2.73 & 0.1 \leq \mathbf{signal}(i) \leq 8 \\ 4 & \mathbf{signal}(i) > 8 \end{cases}$$

The formula above was an approximation to an MTF curve of a typical thermal imager.³⁸⁷

Number of cycles resolved by the imager:

$$N_{Cycles-Resolved}(i) = f_R(i) * C_d / [R(i)/1000]$$

The probability of detection assuming that the target was in the frame:

$$P_{inf}(i) = \left(\frac{N_{Cycles-Resolved}(i)}{N_{50}} \right)^E \cdot \left[1 + \left(\frac{N_{Cycles-Resolved}(i)}{N_{50}} \right)^E \right]^{-1}$$

Where N_{50} was the number of cycles required to be resolved on the target in order to achieve a 50% probability of discrimination (for detect, classify, recognize, identify).

$$E(i) = 2.7 + 0.7 \frac{N_{Cycles-Resolved}(i)}{N_{50}}$$

In order to get the actual probability of detection, $P_{inf}(i)$ needed to be multiplied by the probability that the target will be in the FOV of one of the sensors during one time-step

$$Scan = 1 - \exp[-timestep \cdot N_{sensors} \cdot m \cdot \tau^{-1}]$$

Where:

$N_{sensors}$ was the number of sensors used by the FOB forces.

$$m = \frac{\text{timestep} \cdot \text{ScanRate}_V + \text{FOV}_V}{\text{FOV}_{TOT-V}} \cdot \frac{\text{FOV}_H}{360}$$

m was the probability that a target will be in the current field of view.

$$\boxed{P_{\text{detect}}(i) = P_{\text{inf}}(i) \cdot \text{Scan}}$$

Step 3: All red forces personnel that were not detected advanced towards the FOB at velocity V , during the time-step. Forces that have reached the minimal range of attack – RangeToShoot will stop there. The scenario did not go to step 2 until all red forces reached the RangeToShoot or $N_{\text{Min-Det-To-Engage}}$ were detected.

Step 4: Surprise of the Blue guards: All of the red forces that reached RangeToShoot without being detected shot at the exposed guards for T_{surprise} seconds – until the guards took cover.

Step 5: Battle starts. The Red and blue forces started shooting simultaneously, in their own rate of detection + fire, until one of the sides was annihilated.

Let:

$P_{\text{R-hit-B}}$ - the probability that a red force weapon hit a blue force personnel

$P_{\text{B-hit-R}}$ - the probability that a blue force weapon hit a red force personnel.

Assuming a Gaussian aiming error, the above probabilities were expressed as:

$$\begin{aligned} P_{\text{R-hit-B}} &= \left[\int_{\text{BlueExpH}}^{\text{BlueExpH}} \frac{1}{\sqrt{2\pi} \text{RedErr} \cdot \text{R}(i)} \exp\left(-\frac{y^2}{2 \cdot (\text{RedErr} \cdot \text{R}(i))^2}\right) dy \right] \times \\ &\times \left[\int_{\text{BlueExpW}}^{\text{BlueExpW}} \frac{1}{\sqrt{2\pi} \text{RedErr} \cdot \text{R}(i)} \exp\left(-\frac{x^2}{2 \cdot (\text{RedErr} \cdot \text{R}(i))^2}\right) dx \right] = \\ &= \text{erf}\left[\text{BlueExpH}/2/(\text{RedErr} \cdot \text{R}(i))\right] \cdot \text{erf}\left[\text{BlueExpW}/2/(\text{RedErr} \cdot \text{R}(i))\right] \end{aligned}$$

(erf stands for the error function.)

$P_{R-k-B|h}$ and $P_{B-k-R|h}$ were taken as parameters (see definitions and values in the table above), such that the total probability of kill was:

$$P_{B-k-R} = P_{B-k-R|h} \times P_{B-hit-R} \quad (\text{this was for red forces})$$

The results of the combat were calculated using the Markov chain technique, where the transition between each stage occurred when one person was killed on either side.

Let:

$$P_{\text{transition}} = \begin{bmatrix} I & 0 \\ R & Q \end{bmatrix}$$

Where: I was the identity matrix, R was the transition sub-matrix from transient states to absorbing states, Q was transition sub-matrix from transient states to transient states, 0 was the zeros matrix. Since we assumed that our battle ends when either side was completely annihilated, our absorbing states were when either $n_b=0$ or $n_R=0$, where n_b was the transient number of blue forces, and n_R was the transient number of red forces.

The R-matrix was built from the different combinations of numbers of blue/red forces, and the absorbing states – when either of them was annihilated:

$$R = \begin{matrix} (n_b, n_R) & \begin{matrix} (0,1) & (0,2) & \dots & (0, N_R) & (1,0) & \dots & (N_R, 0) \end{matrix} \\ \left[\begin{matrix} (1,1) \\ (1,2) \\ (1,3) \\ \cdot \\ \cdot \\ (2,1) \\ (2,2) \\ \cdot \\ \cdot \\ (N_B, N_R) \end{matrix} \right] & \left(\begin{matrix} P_{(1,1),(0,1)} & P_{(1,1),(0,2)} & \dots & P_{(1,1),(0, N_R)} & P_{(1,1),(1,0)} & \dots & P_{(1,1),(N_R, 0)} \\ P_{(1,2),(0,1)} & \cdot & \cdot & \cdot & & & P_{(1,2),(N_R, 0)} \\ P_{(1,3),(0,1)} & & & & & & \\ \cdot & & & & & & \\ \cdot & & & & & & \\ P_{(2,1),(0,1)} & & & & & & \\ P_{(2,2),(0,1)} & & & & & & \\ \cdot & & & & & & \\ \cdot & & & & & & \\ P_{(N_B, N_R),(0,1)} & \cdot & \cdot & \cdot & & & P_{(N_B, N_R),(N_R, 0)} \end{matrix} \right) \end{matrix}$$

Where each element $P_{(n^1_B, n^1_R), (n^2_B, n^2_R)}$ stood for the probability of transition from state (n^1_B, n^1_R) to state (n^2_B, n^2_R) . This was actually the probability that Blue would kill a Red first, if $n^2_R = n^1_R$, and $n^2_B = n^1_B - 1$, and the probability that Red would kill a Blue first, if $n^2_B = n^1_B$, and $n^2_R = n^1_R - 1$. If these four variables did not satisfy one of these conditions, then the value of $P_{(n^1_B, n^1_R), (n^2_B, n^2_R)}$ would be zero.

The Q-matrix was built only from the different combinations of numbers of blue/red forces:

$$Q = \begin{matrix} (n_b, n_r) & (1,1) & (1,2) & \dots & (1, N_R) & (2,1) & \dots & (N_B, N_R) \\ \left[\begin{matrix} (1,1) \\ (1,2) \\ (1,3) \\ \cdot \\ \cdot \\ (2,1) \\ (2,2) \\ \cdot \\ \cdot \\ (N_B, N_R) \end{matrix} \right] & \left(\begin{matrix} P_{(1,1),(1,1)} & P_{(1,1),(1,2)} & \dots & P_{(1,1),(1,N_R)} & P_{(1,1),(2,1)} & \dots & P_{(1,1),(N_B,N_R)} \\ P_{(1,2),(1,1)} & \cdot & \cdot & \cdot & & & P_{(1,2),(N_B,N_R)} \\ P_{(1,3),(1,1)} & & & & & & \\ \cdot & & & & & & \\ \cdot & & & & & & \\ P_{(2,1),(1,1)} & & & & & & \\ P_{(2,2),(1,1)} & & & & & & \\ \cdot & & & & & & \\ \cdot & & & & & & \\ P_{(N_B,N_R),(1,1)} & \cdot & \cdot & \cdot & & & P_{(N_B,N_R),(N_B,N_R)} \end{matrix} \right) \end{matrix}$$

If an exponential distribution of the time to detect and designate a Red target in the bush and an exponential distribution of the time to kill, for both sides, was assumed, then the case of one illuminator for blue forces becomes (after some algebraic manipulation):

$$P_{(n^1_B, n^1_R), (n^2_B, n^2_R)} = \begin{cases} 1 - \frac{\lambda^B_{find+designate} \cdot \lambda^B_{kill}}{(\lambda^B_{find+designate} + \lambda^R_{kill}) \cdot (\lambda^B_{kill} + \lambda^R_{kill})} & , n^2_R = n^1_R \ \& \ n^2_B = n^1_B - 1 \\ \frac{\lambda^B_{find+designate} \cdot \lambda^B_{kill}}{(\lambda^B_{find+designate} + \lambda^R_{kill}) \cdot (\lambda^B_{kill} + \lambda^R_{kill})} & , n^2_B = n^1_B \ \& \ n^2_R = n^1_R - 1 \\ 0 & , \textit{otherwise} \end{cases}$$

Where:

$\lambda^B_{find+designate}$ is the rate (sec^{-1}) of target designation (IR illumination) on the Red forces.

λ^B_{kill} is the rate (sec^{-1}) of killing a Red personnel (By blue), given by:

$$\lambda^B_{kill} = \lambda^B_{hit} \cdot \mathbf{P}^B_{kill\ given\ hit} \cdot \mathbf{n}_B$$

Notice that n_B is the transient number of blue forces, not the initial – N_B .

λ^R_{kill} is the rate (sec^{-1}) of killing a Blue personnel, given by:

$$\lambda^R_{kill} = \lambda^R_{hit} \cdot \mathbf{P}^R_{kill\ given\ hit} \cdot \mathbf{n}_R$$

In case of individual and independent designators, we can approximate:

$$\lambda^B_{find+designate} \approx \left(\lambda^B_{find+designate}^{-1} + \lambda^B_{kill}^{-1} \right)^{-1}$$

The expected number of blue personnel killed in the end of the combat, for N_R reds and N_B Blues would be:

$$\mathbf{E}(\text{Number of Blues killed}) = \sum_{k_2} \left([\mathbf{I} - \mathbf{Q}]^{-1} \mathbf{R} \right)_{k_1, k_2} \cdot \mathbf{K}^B_{k_2}$$

Where k_1 is the transient index with a function $f:(i,j) \rightarrow k_1$, and k_2 is the absorbing index, with a function $g:(l,m) \rightarrow k_2$. \mathbf{K}^B is a vector of size $N_B + N_R$, that holds the number of killed personnel for every absorbing state.

After this step the battle “ends”, and the expected number of personnel killed on both sides was extracted.

³⁶¹ Dennis M. Buede, *The Engineering Design of Systems: Models and Methods* (New York: John Wiley & Sons, 2000), 269.

³⁶² Dennis M. Buede, *The Engineering Design of Systems: Models and Methods* (New York: John Wiley & Sons, 2000), 246.

³⁶³ Arnold H. Buss, "Modeling With Event Graph," (Proceeding, Winter Simulation Conference, 1996).

³⁶⁴ Arnold H. Buss, "Component-Based Simulation Modeling," (Proceeding, Winter Simulation Conference, 2000).

³⁶⁵ Arnold Buss, "Basic Event Graph Modeling," (Technical Notes, Simulation News Europe, 2001).

³⁶⁶ Arnold Buss, "Component-Based Simulation Modeling with SIMKIT," (Proceeding, Winter Simulation Conference, 2002).

³⁶⁷ Arnold H. Buss and Paul J. Sanchez, "Building Complex Models with LEGOS (Listener Event Graph Objects)," (Proceeding, Winter Simulation Conference, 2002).

³⁶⁸ Arnold H. Buss and Paul J. Sanchez, "Simple Movement And Detection In Discrete Event Simulation," (Proceeding, Winter Simulation Conference, 2005).

³⁶⁹ Raytheon Technical Services, Customer Logistics Support (CLS) Quarterly Report, *SURC Failure Reporting Analysis and Corrective Action System (FRACAS) Information*, Quarterly Report, 26 March 2007

³⁷⁰ Christopher M. Adams, "Inventory Optimization Techniques, System vs. Item Level Inventory Analysis." Reliability and Maintainability Symposium (RAMS), (2004): 55-60.

³⁷¹ John J. Lupyán, CTR NSWCCD Little Creek, e-mail message, 19 March 2007.

³⁷² Raytheon Integrated Defense System, *SURC Reliability Summary 06-Q2*, Quarterly Report, 31 August 2006.

³⁷³ John J. Lupyán, CTR NSWCCD Little Creek, e-mail message, 19 March 2007.

³⁷⁴ LCDR Frank Okata, in discussion with the authors, 4 April 2007.

³⁷⁵ Benjamin S. Blanchard and Wolter J. Fabrycky, *Systems Engineering and Analysis*, 4th ed. (Upper Saddle River, NJ: Pearson Education, 2006), 376.

³⁷⁶ United States Marine Corps, Small Craft Company, *Operation Phantom Fury (Al-Fajr) After Action Report*, 25 November, 2004.

-
- ³⁷⁷ John J. Lupyan, CTR NSWCCD Little Creek, e-mail message, 19 March 2007.
- ³⁷⁸ Raytheon Technical Services, Customer Logistics Support (CLS) Quarterly Report, *SURC Failure Reporting Analysis and Corrective Action System (FRACAS) Information*, Quarterly Report, 26 March 2007.
- ³⁷⁹ Raytheon Integrated Defense System, *SURC Reliability Summary 06-Q1*, Quarterly Report, 30 April 2006.
- ³⁸⁰ Raytheon Integrated Defense System, *SURC Reliability Summary 06-Q2*, Quarterly Report, 31 August 2006
- ³⁸¹ John J. Lupyan, CTR NSWCCD Little Creek, e-mail message, March 19, 2007.
- ³⁸² James W. Beaver and others, “Systems Analysis of Alternative Architectures for Riverine Warfare in 2010” (MS diss., Naval Postgraduate School, 2006), 65.
- ³⁸³ James W. Beaver and others, “Systems Analysis of Alternative Architectures for Riverine Warfare in 2010” (MS diss., Naval Postgraduate School, 2006), 65.
- ³⁸⁴ James W. Beaver and others, “Systems Analysis of Alternative Architectures for Riverine Warfare in 2010” (MS diss., Naval Postgraduate School, 2006), 66.
- ³⁸⁵ D. Galligan, et al., “MANA (Map Aware Non-uniform Automata) Compressed Help File.” Version 3.0.39. Operations Analysis Section, Defense Technology Agency, New Zealand, April 2005.
- ³⁸⁶ Mathworks, “ MATLAB 7.4: Introduction and Key Features,” *Mathworks*, <http://www.mathworks.com/products/matlab/description1.html>.
- ³⁸⁷ Krzysztof Chrzanowski, *Non Contact Thermometry: Measurement Errors*, (Warsaw, Poland: Polish Chapter of SPIE, 2001), 43.

THIS PAGE INTENTIONALLY LEFT BLANK

6. COST ESTIMATION

6.1 COST ESTIMATE PURPOSE AND COMPONENTS

Cost analysis is the art of weapon system cost estimating. It involves using incomplete, inaccurate, and changing data of an outmoded & ineffective weapon system to derive the precise cost of purchasing an unknown quantity of an undefined weapon to satisfy an overly exaggerated and unvalidated requirement at some time in the future, under uncertain conditions, with a minimum of funds. Cost estimate is an analysis of individual cost elements using established methodologies to project from data to estimated future cost.³⁸⁸

There are two different purposes for conducting cost analysis. First, cost analysis can be used to “translate system/functional requirements associated with programs, projects, or processes into budget requirements to determine and communicate a realistic view of the likely cost outcome, which can form the basis of the plan for executing the work.”³⁸⁹ Or cost analysis is done “to decide which of the possible alternatives is more desirable and recommends a course of action that will steer decision makers towards it and away from undesirable alternatives.”³⁹⁰ The RST used cost analysis to compare feasible alternatives in supply, repair, force protection, and communications. Several physical systems were derived for each functional area. In-depth cost analysis was performed for each system component. And costs were normalized to fiscal year 2007 dollars (FY07\$) for “apples to apples” comparison. The purpose of RST’s cost analysis was to articulate to the decision maker what alternatives had the “biggest bang for their buck”.

“Cost analysis is the process of collecting and analyzing historical data and applying quantitative models, techniques, tools, and databases to predict the future cost of an item, product, program or task. The art of approximating the probable worth (or cost) extent, or character of something based on information available at the time.”³⁹¹ The RST primarily focused on operating and support cost (O&S) over a five year span (2012-2022). O&S costs are the “estimated cost of operating and supporting the fielded system, including all direct and indirect costs incurred in using the system, e.g., personnel,

maintenance (unit and depot), and sustaining investment (replenishment spares). The bulk of life-cycle costs occur in this category.”³⁹²

Procurement costs were analyzed for the communications and force protection alternative architectures since communications and sensor equipment procurement was necessary. “Procurement cost included total cost of procuring the prime equipment; related support equipment; training; initial and war reserve spares; pre-planned product improvements and military construction.”³⁹³ In the developing this cost analysis, the RST was careful not to use any proprietary or for official use only material. All cost estimates were developed from open source material.

6.2 SUPPLY GROUP

The RST looked at the cost of the LCU-1610, LCU-2000, Jim G, and the CH-53E. Procurement cost was obtained for all of the platforms regardless of whether or not they are in the US inventory. Operating and support costs were divided into three categories: mission personnel costs, unit-level consumption costs and intermediate maintenance costs.

For the logistic connectors, mission personnel include the costs of the operators, maintenance personnel and other direct support personnel. Unit-level consumption includes the cost of POL, support supply parts, and training munitions. Intermediate maintenance includes the cost of labor afloat and ashore.

Procurement cost of an LCU-1610 is approximately \$1,146,000.³⁹⁴ O&S cost for the LCU-1610 came from Assault Craft Unit One (ACU-1), who is responsible for 16 LCUs. The cost per hour for O&S was recorded and calculated. Personnel cost was based off of the 14 crewmembers. Unit-level consumption cost was based off of fuel consumption of 64 gallons per hour and the average annual cost for supply parts based off of their records. Intermediate maintenance cost came from their records. In order to calculate the average yearly O&S costs, ACU-1 said that the number of operating hours per craft is 50 hours per month or 600 hours per year.³⁹⁵ Table 50 shows the breakdown of O&S cost.

LCU-1610	FY 07\$
Mission Personnel	\$121,758
Unit Level Consumption	\$145,288
Intermediate Maintenance	\$92,702
Total	\$359,748

Table 50. One Year O&S Cost for LCU-1610³⁹⁶

Procurement cost of an LCU-2000 is approximately \$2,286,000.³⁹⁷ O&S cost for the LCU-2000 came from the Army Operating and Support Management Information System (OSMIS) and calculations based off of crew and fuel consumption. Personnel cost was based off of 17 crewmembers. Fuel consumption was calculated from data concerning fuel capacity, cruising speed, and range.³⁹⁸ Similar to the LCU-1610, the RST assumed that the number of operating hours per craft is 600 hours per year. Because of the LCU-2000's size compared to the LCU-1610, intermediate maintenance was assumed to be 25% more than the LCU-1610 intermediate maintenance cost. The rest of the unit-level consumption cost came from OSMIS. Table 51 shows the breakdown of O&S cost.

LCU-2000	FY 07\$
Mission Personnel	\$171,003
Unit Level Consumption	\$397,098
Intermediate Maintenance	\$115,878
Total	\$568,814

Table 51. One Year O&S Cost for LCU-2000^{399 400}

Procurement cost for the Jim G is approximately \$5 million.⁴⁰¹ Note: the estimated cost is the general market value based on class and age. It cannot be construed as a quote or offer for sale. Yearly fuel consumption was calculated by acquiring the fuel consumption of 55 gallons/hour and assuming that there will be 600 operating hours per year.⁴⁰² O&S cost for mission personnel, other consumables and maintenance is

approximately \$2000 a day.⁴⁰³ Assuming an eight hour workday and 600 operating hours per year, there are 75 operating days. Table 52 shows the breakdown of O&S cost.

Jim G	FY 07\$
Mission Personnel	\$118,980
Unit Level Consumption	\$84,810
Intermediate Maintenance	\$70,680
Total	\$274,470

Table 52. One Year O&S Cost for Jim G⁴⁰⁴

Procurement cost of the CH-53E is \$31,185,000.⁴⁰⁵ O&S cost for the CH-53E came from the Navy Visibility and Management of Operating and Support Costs (VAMOSOC). O&S cost in fiscal year 2007 dollars (FY07\$) from 1997 to 2006 was obtained. The RST calculated annual O&S cost by getting the average cost from the 10 years of data. Table 53 shows the breakdown of O&S cost.

CH-53E	FY 07\$
Mission Personnel	\$623,697
Unit Level Consumption	\$560,401
Intermediate Maintenance	\$435,680
Total	\$1,619,778

Table 53. One Year O&S Cost for CH-53E⁴⁰⁶

The total cost includes procurement cost if applicable plus five year operating and support cost. Assuming an average OPTEMPO, five year O&S cost was calculated by multiplying the annual O&S cost by five. Table 54 and Figure 109 show the total five year cost for the different connectors.

Alternative	Procurement (FY07\$)	Average O&S (FY07\$)	Five Year O&S (FY07\$)	Total Five Year Cost (FY07\$)
LCU-1610	\$1,146,000	\$359,748	\$1,798,740	\$2,944,740
LCU-2000	\$2,286,000	\$568,814	\$2,844,070	\$5,130,070
Jim-G	\$5,000,000	\$274,470	\$1,372,350	\$6,372,350
CH-53E	\$31,185,000	\$1,619,778	\$8,098,888	\$39,283,888

Table 54. Procurement and Five Year O&S Cost for Supply Connectors

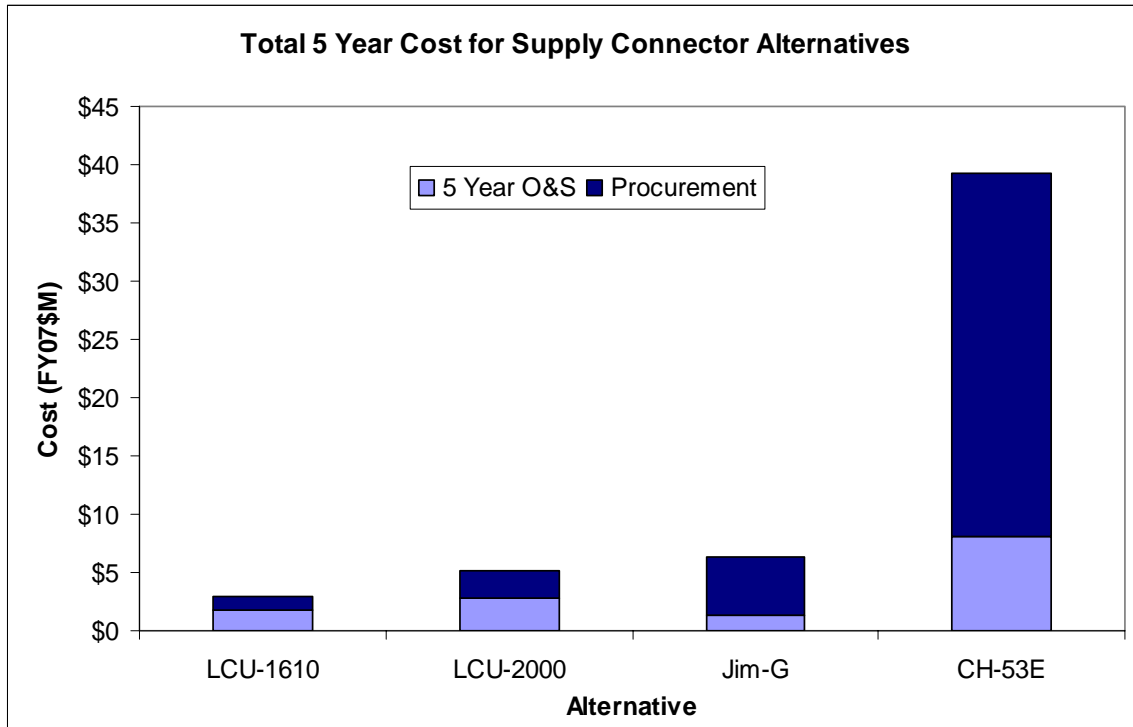

Figure 109. Procurement and Five Year O&S Cost of Supply Connectors

The CH-53E is the most expensive supply connector alternative. If vessels are only used, the Jim G is the most expensive supply vessel alternative. The Jim G is over twice as much as the LCU-1610. The Jim G, however, has the lowest O&S cost. It is over half of the O&S cost of the LCU-2000.

6.3 REPAIR GROUP

This section presents cost estimation for our RF maintenance organization. Parts cost estimates were generated from for official use only (FOUO) data maintained by the

manufacturer, SAFE Boats International, thus some details are omitted for proprietary purposes. Based on our three alternatives, increases to maintenance bays, number of SURC's, and number of skill sets (personnel), there are seven different combinations of alternatives. This estimation was first developed as an initial cost survey for the baseline riverine squadron maintenance section then several alternatives were assessed.

The mission personnel category of the cost estimation relates to the cost of military personnel who perform maintenance on the SURC's and rolling gear. The baseline maintenance team consists of eleven personnel in the following pay grades: 1 E-7, 5 E-5's, and 5 E-4's. This cost will consider their regular military compensation which includes basic pay, basic allowance for subsistence and housing, and tax advantages from untaxed allowances. The information was obtained from data that was listed in the Navy Times 2007 Regular military compensation and represents the average annual military salary earned by service members.⁴⁰⁷ Table 55 represents the total cost of the average annual military salary per year for a total for five years.

Pay Grade	Number of Personnel	Annual Individual Salary (FY07\$)	Total 5 Year Personnel Cost (FY07\$)
E-7	1	\$65,049	\$325,247
E-5	5	\$51,150	\$1,278,748
E-4	5	\$42,944	\$1,073,593
Total	11	\$159,143	\$2,677,588

Table 55. Annual Military Salaries

The remaining four areas of cost estimation, unit-level consumption, intermediate maintenance, contractor support, and sustaining support were obtained from the SURC's LCCE provided by the manufacturing company, which consisted of three years of data.⁴⁰⁸ Regression was used to estimate the cost for the fourth and fifth years, the data was scaled for 12 SURC's then normalized to reflect FY07 dollars resulting in a total cost of \$5,675,634.82 for the baseline maintenance system and is summarized in Table 56.

Maintenance System O&S Cost	Yearly O&S Cost (FY07\$)	Total 5 Year O&S Cost (FY07\$)
MISSION PERSONNEL		
Maintenance Personnel	\$535,518	\$2,677,588
UNIT-LEVEL CONSUMPTION		
Consumable Material / Repair Parts	\$163,236	\$816,182
Training	\$37,056	\$185,279
INTERM. MAINTENANCE		
Maintenance	\$60,064	\$300,320
CONTRACTOR SUPPORT		
Contractor Maintenance Support	\$215,874	\$1,223,426
SUSTAINING SUPPORT		
Modification Kit / Upgrade Procurement / Installation	\$94,568	\$472,840
TOTAL OPERATIONS & SUPPORT	\$1,106,316	\$5,675,635

Table 56. Maintenance System Five Year O&S Cost

Operations personnel, other personnel and expendable stores and munitions were omitted from this cost estimation due to our focus on those cost affecting solely the maintenance system. POL/Expendable Consumption was addressed in the logistics portion of this study.

Unit-level cost was represented by cost of consumable material/repair parts. Consumable repair cost was an estimate from the older riverine assault craft (RAC) and includes the cost of all maintenance materials required to sustain the SURC. Training reflected the cost to train the eleven mechanics and is based off an estimate from the cost of training the Marine Corps equivalent engineer equipment mechanic. Intermediate maintenance cost reflected the cost of labor related to 3rd/4th echelon support external to the unit. Contractor support and contractor maintenance support estimated the cost of labor, materials, and overhead incurred in providing logistics support to the SURC. Sustaining support cost includes an estimate of the cost of installing modifications and upgrades and is again based on estimates from the RAC.

In addition to the O&S cost, each alternative contributed a procurement cost dependant on how alternatives were applied to the maintenance system. The following table lists the three alternatives and their cost in FY07 dollars. It is important to note, that the SURC will be used as a float boat so we assumed O&S would be negligent and only

considered its procurement cost. Furthermore, in the case of the maintenance bay, the procurement cost was only considered, as the O&S for the tent would be minimal.

Alternatives	Five Year O&S Cost (FY07\$)	Personnel (FY07\$)	SURC (FY07\$)	Bay (FY07\$)	Total (FY07\$)
Personnel	\$5,675,635	\$51,150	\$0	\$0	\$5,726,785
SURC	\$5,675,635	\$0	\$671,825	\$0	\$6,347,460
Bay	\$5,675,635	\$0	\$0	\$33,628	\$5,709,263
Personnel & SURC	\$5,675,635	\$51,150	\$671,825	\$0	\$6,398,610
Personnel & Bay	\$5,675,635	\$51,150	\$0	\$33,628	\$5,760,413
SURC & Bay	\$5,675,635	\$0	\$671,825	\$33,628	\$6,381,088
Personnel & SURC & Bay	\$5,675,635	\$51,150	\$671,825	\$33,628	\$6,432,238

Table 57. Five Year O&S Cost of Repair Alternatives

The cost of an E-5 with 10 years service was chosen as an assumption of the various times in service and pay grades of additional personnel. From the Table 57, we can see the great cost comes from the SURC or any alternatives involving the SURC. The least expensive means of affecting the maintenance system was through the addition of maintenance bays.

6.4 FORCE PROTECTION GROUP

The cost estimation for FPS was similar to the other sections in the study and consisted of procurement and five year operations and support costs. The estimates were generated from open source information available on the internet, discussions with vendors, and comparisons with analogous systems. Personnel cost were a large driver of O&S costs for each alternative. Each person was assumed an E-5 with 10 years. The cost was taken from the Regular Military Compensation, which is the average annual military salary earned by service member.⁴⁰⁹

6.4.1 Mortar Alternatives

Table 58 is the cost for the mortar alternatives.

Mortar Alternatives	Procurement	5 year O&S	Total Cost
Baseline (already in RF)	\$0	\$0	\$0
Mortar and UAV	\$93,000	\$2,493,500	\$2,586,500
Mortar	\$18,000	--	\$18,000
Five man crew	--	\$1,535,000	\$1,535,000
Three Silver Fox UAVs	\$75,000	\$37,500	\$112,500
Three UAV operators	--	\$921,000	\$921,000
Mortar and LCMR	\$668,000	\$1,560,000	\$2,228,000
Mortar and crew (above)	\$18,000	\$1,535,000	\$1,553,000
LCMR	\$650,000	\$25,000	\$675,000
Mortar, LCMR, UAV	\$743,000	\$2,518,500	\$3,261,500
Mortar and crew (above)	\$18,000	\$1,535,000	\$1,553,000
UAV and crew (above)	\$75,000	\$958,500	\$1,033,500
LCMR	\$650,000	\$25,000	\$675,000

Table 58. Mortar Alternatives Cost Estimation

The baseline cost for mortar defense was assumed to be zero, as there were no components used to counter the mortar threat for the baseline architecture.

The M120 Mortar costs \$18,000 each and requires a 5-men crew. The RST assumed that this was the only crew required as the mortar will not require constant manning. The maintenance for the mortar was assumed as zero because it is an offensive weapon which will only be employed in the event of an attack by insurgents. Daily maintenance at the FOB would be carried out by the operators themselves. The operations and support costs included the personnel cost for the 5 members of the crew. With 5 members, the total operating and support cost for a five year period was approximately \$1,535,000.

The procurement cost for each Silver Fox was assumed to be \$25,000 as the current prototype costs \$50,000,⁴¹⁰ and production costs are typically half that of prototypes. Because the Silver Fox has an approximate 8 hour loiter time, three would have to have continuous patrol. The RST assumed that one person would be required to

operate the Silver Fox for each eight-hour period, so the cost was generated for three people.

The mortar and LCMR architecture had the equivalent cost of the mortar and crew with the addition of the cost of an LCMR. The LCMR costs approximately \$650,000 to procure.⁴¹¹ The radar, originally designed for special operations forces, consists mainly of electronic parts which will be replaced rather than repaired when damaged. The cost estimate for one system was estimated at \$5,000 a year in an analogous relationship with the larger AN/TPQ 37 Firefinder Radar. The estimate was based on the data available for the maintenance cost for AN/TPQ 37 Firefinder Radar on OSMISWEB⁴¹². The Firefinder Radar cost \$50,000 a year to maintain, based on the figures available for FY2000-2006. LCMR's maintenance cost was estimated at 10% of the Firefinder based on the size ratio of both the systems, for a total cost of \$5,000 per system per year, for a total cost of \$25,000. Personnel in the TOC that were already a part of the RF would operate and maintain the LCMR, so no additional personnel cost was included in the 5 year O&S costs. The cost of the mortar, LCMR, and UAV architecture was a combination of the costs previously discussed.

6.4.2 Commando Raid

Table 59 is the cost for the Commando Raid alternatives.

Commando Raid Alternatives	Procurement	5 year O&S	Total Cost
Baseline	\$0	\$11,048,000	\$11,048,000
36 Augment personnel	--	\$11,048,000	\$11,048,000
Baseline, Sensor Fence, and Mortar			
36 Augment personnel	\$38,900	\$12,598,700	\$12,637,600
Mortar	--	\$11,048,000	\$11,048,000
Five man crew	\$18,000	--	\$18,000
Sensor Fence	--	\$1,535,000	\$1,535,000
	\$20,900	\$15,700	\$36,600
ROSAMS			
6 ROSAMS	\$1,200,000	\$6,424,000	\$7,624,000
18 Operators	\$1,200,000	\$900,000	\$2,100,000
	\$0	\$5,524,000	\$5,524,000

Table 59. Commando Raid Alternatives Cost Estimation

The baseline architecture consisted of 12 personnel manning six machine guns. The RST established three rotations of these personnel to provide a continuous manning in three 8-hour shifts, for a total of 36 personnel. The cost estimation excludes all the training and development of the personnel prior to their deployment in the Area of Operations. The figure is based purely on the compensation that these 36 E5 will receive over the period of 5 years.

The next architecture added the cost of the mortar and Sensor Fence to the baseline cost. The cost of the mortar was the same as that in the mortar alternatives. Actual cost of the Sensor Fence could not be gathered, but the cost of the fence system employed in this configuration was approximately \$20,900. The RST assumed that 10 nodes would be needed for the Sensor Fence, with the cost of each node at \$8000. The RF would also need to procure a computer and software which would cost approximately \$12000. The cost of the waveguide wire, clips, and miscellaneous hardware amounted to approximately \$1 per meter, and the fence employed was approximately 900 meters long. The operating and support cost for the system was assumed at approximately 15% of the total cost each year for a total five year O&S cost of approximately \$15,700.

The cost for the ROSAM was \$200,000 each for procurement for a total of \$1,200,000.⁴¹³ The O&S costs were considered to be %15 of the total procurement costs each year. For a five year period, this put the total O&S cost at \$900,000. The RST assumed that one operator would be required for each system for 8 hours, so the total number of personnel required was 18.

6.4.3 FOB Boat Attack

Table 60 is the cost for the FOB Boat Attack alternatives.

FOB Boat Attack	Procurement	5 year O&S	Total Cost
<u>Baseline</u>	\$0	\$7,366,000	\$7,366,000
24 Augment personnel	--	\$7,366,000	\$7,366,000
<u>Baseline and Water Barrier</u>			
	\$400,000	\$7,374,250	\$7,774,250
24 Augment personnel	--	\$7,366,000	\$7,366,000
Water barrier	\$400,000	\$8,250	\$408,250
<u>Water Barrier and ROSAMS</u>			
	\$1,200,000	\$4,291,250	\$5,491,250
Water Barrier	\$400,000	\$8,250	\$408,250
4 ROSAMS	\$800,000	\$600,000	\$1,400,000
12 Operators	--	\$3,683,000	\$3,683,000
<u>Baseline, Water Barrier, and Patrol Boats</u>			
	\$608,000	\$10,292,250	\$10,900,250
Baseline + Barrier (above)	\$400,000	\$7,374,250	\$7,774,250
2 Patrol Boats	\$208,000	\$156,000	\$364,000
9 PB operators	\$0	\$2,762,000	\$2,762,000
<u>ROSAM, Water Barrier, and Patrol Boats</u>			
	\$1,408,000	\$7,209,250	\$8,617,250
ROSAMs + Barrier (above)	\$1,200,000	\$4,291,250	\$5,491,250
2 Patrol Boats	\$208,000	\$156,000	\$364,000
9 PB operators	\$0	\$2,762,000	\$2,762,000

Table 60. Cost Estimation for FOB Boat Attack Alternatives

The baseline architecture contained four machine gun posts along the river requiring eight personnel. Again, eight-hour watches were assumed making the total number of personnel necessary 24.

The WhisprWave Barrier employed in this architecture was approximately 1000 feet long. The manufacturer quoted the required system at \$400 per linear foot, making the total procurement cost approximately \$400,000.⁴¹⁴ This configuration was outfitted with an additional spare parts kit for repairs per every 200 linear feet, at a cost of \$1,650 per kit.⁴¹⁵ The number of kits required would be five, so the total expense was \$8,250. The RST assumed no other cost other than the initial cost of the repair kits for O&S costs.

The Water Barrier and ROSAMs architecture had the equivalent cost of the WhisprWave barrier in addition to the cost of four ROSAMs. The ROSAMs had the

same breakdown in cost at \$200,000 each for procurement, and %15 annual O&S, as discussed in the Commando Raid architectures. For four ROSAMs, the O&S cost was \$600,000. Again, the RST assumed the systems required three operators each for a 24-hour day for a total of 12 operators.

This architecture had the same cost estimations for the baseline and Water Barrier architectures with the addition of a PB. The RST assumed that two PBs would be procured in case of one malfunction. The PB required a crew of three, so nine operators would be needed for 24-hour operations. The procurement cost for a PB was \$68,000 each, or \$132,000 for both.⁴¹⁶ The RST assumed 10% O&S costs for each patrol boat for a five year period for a total of \$68,000 total O&S. The crew required to operate a PB is three personnel, and to maintain the three shifts, nine personnel were used. The final cost estimation for the ROSAM, Water Barrier, and PB architecture was simply a summation of the various components of the previous architectures.

6.4.4 MOB Boat Attack

Table 61 is the cost for the MOB Boat Attack alternatives.

MOB Boat Attack	Procurement	5 year O&S	Total Cost
<u>RCSS Baseline</u>	\$0	\$9,207,000	\$9,207,000
30 Weapon Station Personnel	\$0	\$9,207,000	\$9,207,000
<u>RCSS and Patrol Boats</u>			
RCSS baseline	\$208,000	\$12,125,000	\$12,333,000
2 Patrol Boats	\$0	\$9,207,000	\$9,207,000
9 PBL operators	\$208,000	\$156,000	\$364,000
	\$0	\$2,762,000	\$2,762,000
<u>Nobriza and Barge Baseline</u>			
24 Weapon Station Personnel	\$0	\$7,366,000	\$7,366,000
		\$7,366,000	\$7,366,000
<u>Nobriza and Barge Baseline, Patrol Boats, Barrier</u>			
Nobriza and Barge Baseline	\$336,000	\$10,287,300	\$10,623,300
Barrier		\$7,366,000	\$7,366,000
2 Patrol Boats	\$128,000	\$3,300	\$131,300
9 PBL operators	\$208,000	\$156,000	\$364,000
	\$0	\$2,762,000	\$2,762,000

Table 61. Cost Estimation for MOB Boat Attack Alternatives

The baseline cost for the RCSS was derived from the personnel required to man the 8 universal weapon stations and the 25 mm chain guns on the ship. Each weapon station required one personnel and the same shift rotation was applied. This made the total personnel necessary up to 30 personnel.

The components in the other architectures for this scenario match the components in the FOB Boat Attack scenario. The cost for the PB's and their required personnel, for example, had the same cost. The cost of the WhisprWave barrier was less in this scenario, however because the length of the configured barrier was less than a third of the barrier constructed for the FOB, at 320 feet. With the same cost of \$400 per foot, the cost to procure the barrier in this scenario was \$128,000. The RST assumed that two of the repair kits were procured for the O&S costs, so the O&S costs for the barrier in this scenario was \$3,300.

6.5 MOBILE OPERATING BASE

The RST calculated the operating and support cost of the RCSS, RSS-207 Endurance, KD-1505 Sri Inderapura, Nobriza, and a barge. Because the RST's scenario involves coalition operations, the RST did not include procurement costs for military platforms except for the Nobriza; there exists possibilities of procuring the Nobriza to add to the USN inventory. There was also conversion cost for the RCSS. Operating and support costs were divided into six categories: mission personnel, unit-level consumption, intermediate maintenance, depot maintenance, sustaining support, and indirect support.

Mission personnel include the operators, maintenance personnel and other direct support personnel. Unit-level consumption includes the cost of POL, support supply parts, and training munitions. Intermediate maintenance includes the cost of labor afloat and ashore. Depot maintenance includes the cost of labor in performing major overhauls. Sustaining support includes any system improvements or modifications. Finally, indirect support includes programs necessary to maintain a quality of force and installation support. Note: O&S cost for specific platforms could not be found. Instead, the RST

compared the cost to similar platforms whose data could be found through VAMOSC and estimated the cost based on number of crew and size of the platform.

Cost for the RCSS came from the RCSS Conversion report as well as VAMOSC. According to the report, the conversion cost is approximately \$166 million.⁴¹⁷ Table 62 shows the breakdown of the conversion cost.

Conversion	FY 05\$
Industrial Availability	\$22,000,000
Logistics Support	\$11,000,000
Program Management	\$2,000,000
Modification (Addition)	\$111,000,000
Modification (Removal))	\$2,000,000
Total	\$148,000,000

Table 62. RCSS Conversion Cost⁴¹⁸

After inflation the conversion cost in FY07\$ is approximately \$167 million. Because the RCSS is a conversion of the LST-1179 class ship, O&S cost for the RCSS came from the average O&S cost of the LST-1179 class from 1989 to 1994 retrieved from VAMOSC. Table 63 shows the breakdown of O&S cost for the RCSS.

LST-1179	FY 07\$
Mission Personnel	\$9,322,542
Unit Level Consumption	\$4,520,611
Intermediate Maintenance	\$380,248
Depot Maintenance	\$4,692,206
Sustaining Support	\$1,149,858
Indirect Support	\$632,495
Total	\$20,697,959

Table 63. One Year O&S Cost for RCSS (LST-1179 Class)⁴¹⁹

The same data for O&S cost can be used for the KD-1505 Sri Inderapura since it is a former LST-1179 Class ship.

O&S cost for the RSS-207 Endurance class was obtained by making estimations based off of the LPD-4 Austin class amphibious transport dock. The two ships are similar in design and mission, but the Austin is slightly bigger and has a larger crew. The overall length is 570 feet and the crew accommodation is 492.⁴²⁰ Because the length of the Endurance is 460 feet, which is 80% of the Austin, the RST estimated the unit level consumption, maintenance, and support cost to be 80% of that of the Austin. Mission personnel cost of Endurance was estimated to be 15% of that of the Austin since the Endurance has a crew of only 65.⁴²¹ Table 64 shows the breakdown of O&S cost for the Endurance.

Endurance	FY 07\$
Mission Personnel	\$2,912,303
Unit Level Consumption	\$7,172,018
Intermediate Maintenance	\$621,971
Depot Maintenance	\$11,160,488
Sustaining Support	\$806,392
Indirect Support	\$1,549,235
Total	\$24,222,406

Table 64. One Year O&S Cost for RSS-207 Endurance Class (Estimated from LPD-4)⁴²²

Cost for the barge came from data collected on the ARL-1 Achelous class landing craft repair ship from VAMOSOC. The design of the ship is similar to the APB's and APL's used during the Vietnam War. The RST estimated the mission personnel cost to be 20% of that of the Achelous since the crew of the Achelous was approximately 190 and the barge was estimated to be 30.⁴²³ Unit level consumption was estimated to be 10% of that of the Achelous since the barge is not self-propelled. Other O&S cost was assumed to be the same. Table 65 is a breakdown of O&S cost for a barge.

Barge	FY 07\$
Mission Personnel	\$1,513,840
Unit Level Consumption	\$467,940
Intermediate Maintenance	\$69,342
Depot Maintenance	\$3,151,318
Sustaining Support	\$4,184,435
Indirect Support	\$329,128
Total	\$9,716,003

Table 65. One Year O&S Cost for a Barge (Estimated from ARL-1)⁴²⁴

Procurement cost for the Nobriza is approximately \$9 million.⁴²⁵ O&S cost for the Nobriza was obtained by making estimations based off of data on PC-1 Cyclone class patrol craft. The crew of the Nobriza is close to that of the Cyclone, but the size is approximately 25% smaller.⁴²⁶ For that reason, the RST estimated the O&S cost other than mission personnel to be 75% of that of the Cyclone. Table 66 is a breakdown of O&S cost for the Nobriza.

Nobriza	FY 07\$
Mission Personnel	\$1,971,892
Unit Level Consumption	\$881,014
Intermediate Maintenance	\$71,364
Depot Maintenance	\$294,664
Sustaining Support	\$12,386
Indirect Support	\$98,887
Total	\$3,330,207

Table 66. One Year O&S Cost for Nobriza (Estimated from PC-1)⁴²⁷

The total cost includes procurement cost if applicable or conversion cost for the RCSS plus five year operating and support cost. Assuming an average OPTEMPO, five year O&S cost was calculated by multiplying the annual O&S cost by five. Table 67 and Figure 110 show the total five year cost for the different connectors.

Alternative	Procurement (FY07\$)	Average O&S (FY07\$)	Five Year O&S (FY07\$)	Total Five Year Cost (FY07\$)
RCSS	\$166,000,000	\$20,697,959	\$103,489,794	\$269,489,794
Endurance	\$0	\$24,222,406	\$121,112,032	\$121,112,032
Sri-Inderapura	\$0	\$20,697,959	\$103,489,794	\$103,489,794
Nobriza+Barge	\$9,000,000	\$13,046,211	\$65,231,054	\$74,231,054

Table 67. Procurement and Five Year O&S Costs for MOB Alternatives

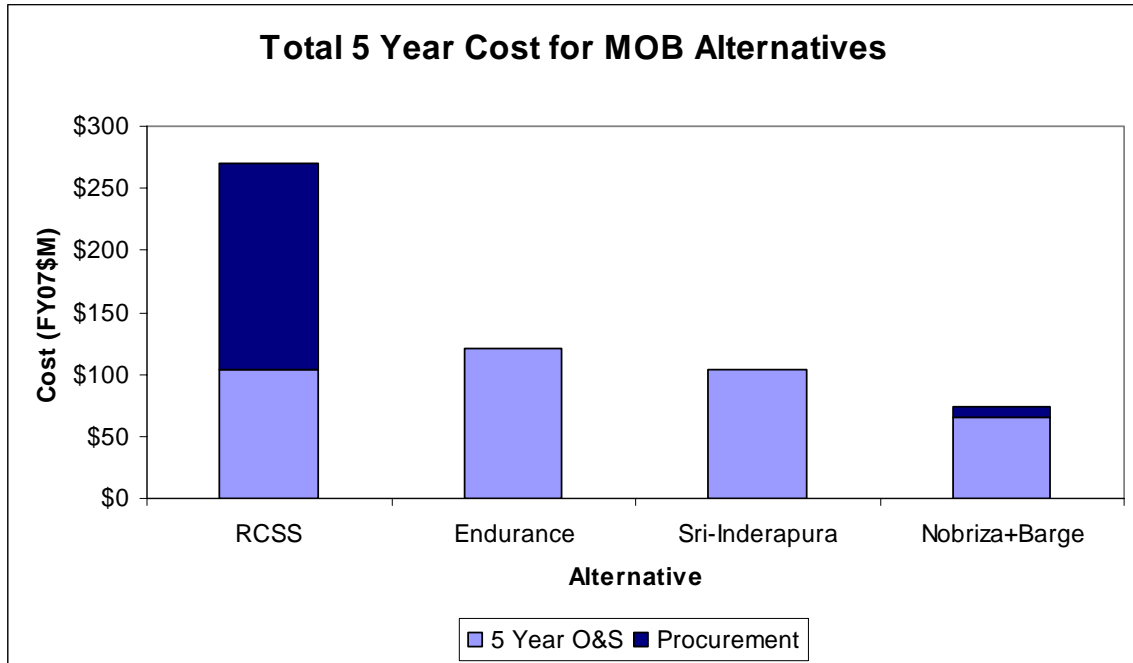

Figure 110. Procurement and Five Year O&S Costs of MOB Alternatives

The most expensive MOB alternative is the RCSS because of the added modification cost. The Endurance is the most expensive with regard to O&S cost. The O&S cost for the Nobriza + Barge is nearly half that of the Endurance because of its smaller size and lower fuel consumption.

Operating and support cost for the GFS was based on the LSD-49 Harpers Ferry class dock landing ship. Similar to the MOB, O&S cost was divided into six categories: mission personnel, unit-level consumption, intermediate maintenance, depot maintenance, sustaining support, and indirect support of the platform. Cost for the LSD-

49 came from VAMOSC. The RST calculated annual O&S cost by getting the average cost from 1998-2006 in FY07\$. Table 68 shows the breakdown of O&S cost.

LSD-49	FY 07\$
Mission Personnel	\$16,747,582
Unit Level Consumption	\$6,973,573
Intermediate Maintenance	\$697,277
Depot Maintenance	\$7,047,135
Sustaining Support	\$1,720,803
Indirect Support	\$1,638,187
Total	\$34,824,556

Table 68. Five Year O&S Cost for GFS (LSD-49)⁴²⁸

For analysis purposes, the RST assumed that the GFS will be a military platform, so procurement cost was not taken accounted for. Assuming an average OPTEMPO, five year O&S cost was calculated by multiplying the annual O&S cost by five. Doing so resulted in a total cost of \$174 million.

³⁸⁸ Daniel A. Nussbaum, *OS3703 Systems Assessment Course Notes; Cost Estimation*, (Naval Postgraduate School, 29 January 2007), slides.

³⁸⁹ Daniel A. Nussbaum, *OS3703 Systems Assessment Course Notes; Cost Estimation*, (Naval Postgraduate School, 29 January 2007), slides.

³⁹⁰ Daniel A. Nussbaum, *OS3703 Systems Assessment Course Notes; Cost Estimation*, (Naval Postgraduate School, 29 January 2007), slides.

³⁹¹ Daniel A. Nussbaum, *OS3703 Systems Assessment Course Notes; Cost Estimation*, (Naval Postgraduate School, 29 January 2007), slides.

³⁹² Daniel A. Nussbaum, *OS3703 Systems Assessment Course Notes; Cost Estimation*, (Naval Postgraduate School, 29 January 2007), slides.

³⁹³ Daniel A. Nussbaum, *OS3703 Systems Assessment Course Notes; Cost Estimation*, (Naval Postgraduate School, 29 January 2007), slides.

³⁹⁴ Paul Mulcahy, “LCU,” *U.S. Watercraft*, http://www.pmulcahy.com/watercraft/us_watercraft.htm.

³⁹⁵ Arnel Florendo, LT ACU ONE Supply Officer, e-mail message to the author, 5 May 2007.

³⁹⁶ Arnel Florendo, LT ACU ONE Supply Officer, e-mail message to the author, 5 May 2007.

³⁹⁷ Paul Mulcahy, “LCU,” *U.S. Watercraft*, http://www.pmulcahy.com/watercraft/us_watercraft.htm.

³⁹⁸ U.S. Department of the Army, *Landing Craft. Utility (LCU 2000) Technical Manual (TM) 55-1905-223-10*, 17 January 1989 (Washington, DC: GPO, 1989) 1-70.

³⁹⁹ U.S. Department of the Army, *Landing Craft. Utility (LCU 2000) Technical Manual (TM) 55-1905-223-10*, 17 January 1989 (Washington, DC: GPO, 1989) 1-70.

⁴⁰⁰ Cost and Economics Office of the Deputy Assistant Secretary of the Army, “CAIG Cost Element Structure,” *OSMIS*, <https://www.osmisweb.com>.

⁴⁰¹ Vince Manzo, SEACOR Marine, phone message to the author, 22 May 2007.

⁴⁰² SEACOR Marine, “Jim G,” *SEACOR Marine*, <http://www.seacormarine.com/ourfleet.cgi?type=ms>.

-
- ⁴⁰³ Vince Manzo, SEACOR Marine, phone message to the author, 22 May 2007.
- ⁴⁰⁴ SEACOR Marine, “Jim G,” *SEACOR Marine*, <http://www.seacormarine.com/ourfleet.cgi?type=ms>.
- ⁴⁰⁵ Federation of American Scientists, “CH-53 Sea Stallion,” *Federation of American Scientists*, <http://www.fas.org/man/dod-101/sys/ac/h-53.htm>.
- ⁴⁰⁶ Naval Center for Cost Analysis, “ATMSR TMS Query,” *Navy VAMOS*, <http://www.navyvamosc.com/>.
- ⁴⁰⁷ Navy Times, “2007 Regular Military Compensation,” *Navy Times*, http://www.navytimes.com/static/money/pay_charts/2007regularmilitarycompensation/.
- ⁴⁰⁸ U.S. Naval Surface Warfare Center, *Riverine Assault Craft Replacement Craft Study*. (West Bethesda, MD, 2000), 19.
- ⁴⁰⁹ Navy Times, “2007 Regular Military Compensation,” *Navy Times*, http://www.navytimes.com/static/money/pay_charts/2007regularmilitarycompensation/.
- ⁴¹⁰ Dave Moniz, “5-foot-long plane to run recon missions for Marines,” *USA Today*, 25 Mar 2004, http://www.usatoday.com/news/washington/2004-04-25-drone-usat_x.htm.
- ⁴¹¹ StrategyPage, “Counter-mortar Radar,” *StrategyPage.com*, <http://www.strategypage.com/htm/htart/articles/20040119.aspx>.
- ⁴¹² United States. Dept of Defense, Cost and Economics Office of the Deputy Assistant Secretary of the Army, *O&S Cost Web. O&S Cost for FY 2000-2006*, <http://www.osmisweb.com>.
- ⁴¹³ Nigel Wasil, “Remote Operated Small Arms Mount (ROSAM),” *NAVSEA Warfare Centers*, www.dtic.mil/ndia/2004arms/session7/wasil.ppt.
- ⁴¹⁴ Frederick W. Burgard, Senior Vice President Sales, Wave Dispersion Technologies, Inc. email to authors, 15 May 2007.
- ⁴¹⁵ Frederick W. Burgard, Senior Vice President Sales, Wave Dispersion Technologies, Inc. email to authors, 15 May 2007.
- ⁴¹⁶ U.S. Department of the Navy, *Assembly Item for Patrol Boat: Boston Whaler Type*, (Washington, DC: GPO, [2007?]).

⁴¹⁷ Clint Lawler, Greg Mitchell, and Il Suh, “Riverine Combat Support Ship (RCSS),” (Report, Massachusetts Institute of Technology, MA, 2006), 62.

⁴¹⁸ Clint Lawler, Greg Mitchell, and Il Suh, “Riverine Combat Support Ship (RCSS),” (Report, Massachusetts Institute of Technology, MA, 2006), 62.

⁴¹⁹ Naval Center for Cost Analysis, “Ship Class Average Query,” *Navy VAMOSC*, <http://www.navyvamosc.com/>.

⁴²⁰ U.S. Department of the Navy, *Marine Corps Reference Publication (MCRP) 3-31B: Amphibious Ships and Landing Craft Data Book*, 29 August 2001, (Washington, DC: GPO, 2001), 9.

⁴²¹ Singapore Technologies Engineering, “141m Landing Ship Tank,” *Singapore Technologies Engineering*, <http://www.stengg.com/CoyCapPro/detail.aspx?cylid=&pdid=104>.

⁴²² Naval Center for Cost Analysis, “Ship Class Average Query,” *Navy VAMOSC*, <http://www.navyvamosc.com/>.

⁴²³ Naval Center for Cost Analysis, “Ship Class Average Query,” *Navy VAMOSC*, <http://www.navyvamosc.com/>.

⁴²⁴ Naval Center for Cost Analysis, “Ship Class Average Query,” *Navy VAMOSC*, <http://www.navyvamosc.com/>.

⁴²⁵ Evin Thompson, CAPT USSOCOM NSWG4, e-mail message to the author, 22 May 2007.

⁴²⁶ Gary P. Priolo, “PC-1 Cyclone,” *NavSource Online*, <http://www.navsource.org/archives/12/0301.htm>.

⁴²⁷ Naval Center for Cost Analysis, “Ship Class Average Query,” *Navy VAMOSC*, <http://www.navyvamosc.com/>.

⁴²⁸ Naval Center for Cost Analysis, “Ship Class Average Query,” *Navy VAMOSC*, <http://www.navyvamosc.com/>.

7. ANALYSIS AND RESULTS

7.1 SUPPLY GROUP ASSUMPTIONS AND LIMITATIONS

7.1.1 SIMKIT Assumptions

7.1.1.1 Three Types of Operating Base

There were three types of operating bases that the supply ship could provide supplies to.

- Forward Operating Base (FOB)
- Mobile Operating Base at a fixed location (MOB1)
- Mobile Operating Base at different locations (MOB2)

7.1.1.2 Four Types of Supply Connectors

The supplies from the supply ship were transported to the operating bases using combinations of the following supply connectors:

- Landing Craft Utility (LCU 1610)
- Off-Shore Marine Support Vessel (SEACOR Jim G)
- Landing Craft Utility (LCU 2000)
- Heavy-Lift Transport Helicopters (CH-53)

7.1.1.3 Number of Configurations (Combinations of Supply Connectors)

The number of configurations was limited by assuming that there could only be a maximum of two supply vessels and two helicopters and that the MOB2 would not be able to support an LCU-2000.

- There were 29 configurations for both FOB and MOB1.
- There were 17 configurations for MOB2.

Table 69 shows the different configurations of the supply connectors.

Combination for FOB and MOB1				Combination for MOB2			
LCU-1610	Jim G	LCU-2000	CH-53	LCU-1610	Jim G	LCU-2000	CH-53
0	0	0	1	0	0	0	1
0	0	0	2	0	0	0	2
0	0	1	0	0	1	0	0
0	0	1	1	0	1	0	1
0	0	1	2	0	1	0	2
0	0	2	0	0	2	0	0
0	0	2	1	0	2	0	1
0	0	2	2	0	2	0	2
0	1	0	0	1	0	0	0
0	1	0	1	1	0	0	1
0	1	0	2	1	0	0	2
0	1	1	0	1	1	0	0
0	1	1	1	1	1	0	1
0	1	1	2	1	1	0	2
0	2	0	0	2	0	0	0
0	2	0	1	2	0	0	1
0	2	0	2	2	0	0	2
1	0	0	0				
1	0	0	1				
1	0	0	2				
1	0	1	0				
1	0	1	1				
1	0	1	2				
1	1	0	0				
1	1	0	1				
1	1	0	2				
2	0	0	0				
2	0	0	1				
2	0	0	2				

Table 69. Configurations for Supply Connector

7.1.2 SIMKIT Limitations

The simulation model was developed using SIMKIT which is a DES-based simulation. The complexity of the model construction increases with the problem scope definition.

The results from the runs for different weather types turned out to have little variation. This was due to the supply crafts having the same speed and capacity reduction factors for the different weather types. One way to overcome this limitation is to assign different speed and capacity reduction factors for all the supply crafts. This is more

realistic as some supply crafts can perform better than others in certain weather conditions.

7.1.3 SIMKIT Analysis of FOB

7.1.3.1 Supply Ship On-Station Time

The Measure of Performance was to minimize supply ship presence duration. Table 70 was generated for the FOB supply ship on-station times for clear weather with re-supply varying between 4 and 9 days, and Config: # LCU1610 #Seacor #LCU20000 #Helo

	4 Days	5 Days	6 Days	7 Days	8 Days	9 Days
Config: 0 0 0 1	1605.45	2014.79	2419.58	2815.47	3220.19	3622.25
Config: 0 0 0 2	702.97	879.72	1059.56	1234.52	1411.01	1594.60
Config: 0 0 1 0	67.91	84.41	101.02	117.44	1271.88	1339.64
Config: 0 0 1 1	62.83	79.48	96.12	112.96	141.97	427.14
Config: 0 0 1 2	57.76	74.28	90.88	107.71	124.07	189.45
Config: 0 0 2 0	67.79	84.44	101.19	117.71	130.03	131.00
Config: 0 0 2 1	62.65	79.50	96.14	113.04	127.96	131.00
Config: 0 0 2 2	57.61	74.42	91.26	107.68	123.92	130.94
Config: 0 1 0 0	67.83	84.17	101.22	117.71	134.58	151.59
Config: 0 1 0 1	62.69	79.40	96.00	112.95	129.30	146.20
Config: 0 1 0 2	57.81	74.27	90.79	107.73	124.15	141.12
Config: 0 1 1 0	67.75	84.55	101.02	117.70	132.20	141.50
Config: 0 1 1 1	62.70	79.50	96.26	113.05	128.96	139.03
Config: 0 1 1 2	57.57	74.35	90.94	107.58	124.22	136.00
Config: 0 2 0 0	67.81	84.39	101.23	117.99	134.42	151.06
Config: 0 2 0 1	62.83	79.28	96.24	112.25	129.50	145.58
Config: 0 2 0 2	57.71	74.38	91.14	107.70	124.35	141.05
Config: 1 0 0 0	1219.31	1196.18	2274.40	2339.16	3333.67	3411.72
Config: 1 0 0 1	302.89	702.26	1104.56	1202.96	1218.86	1239.55
Config: 1 0 0 2	129.99	305.91	484.94	658.41	840.22	1019.99
Config: 1 0 1 0	63.07	68.62	76.17	64.75	81.09	97.82
Config: 1 0 1 1	60.23	66.28	74.17	66.34	76.20	92.81
Config: 1 0 1 2	57.58	63.88	71.71	72.19	70.68	87.70
Config: 1 1 0 0	62.69	68.66	76.63	90.07	106.83	104.40
Config: 1 1 0 1	60.17	66.23	74.14	85.09	102.67	107.77
Config: 1 1 0 2	57.71	63.78	71.79	80.85	97.80	108.24
Config: 2 0 0 0	54.00	54.00	503.75	1213.15	1233.11	1243.67
Config: 2 0 0 1	55.80	54.00	54.00	203.97	605.88	1018.86
Config: 2 0 0 2	53.91	54.00	54.00	96.18	261.94	436.84

Table 70. FOB – Supply Ship Presence Duration

A three-dimensional visualization of the table is seen in Figure 111.

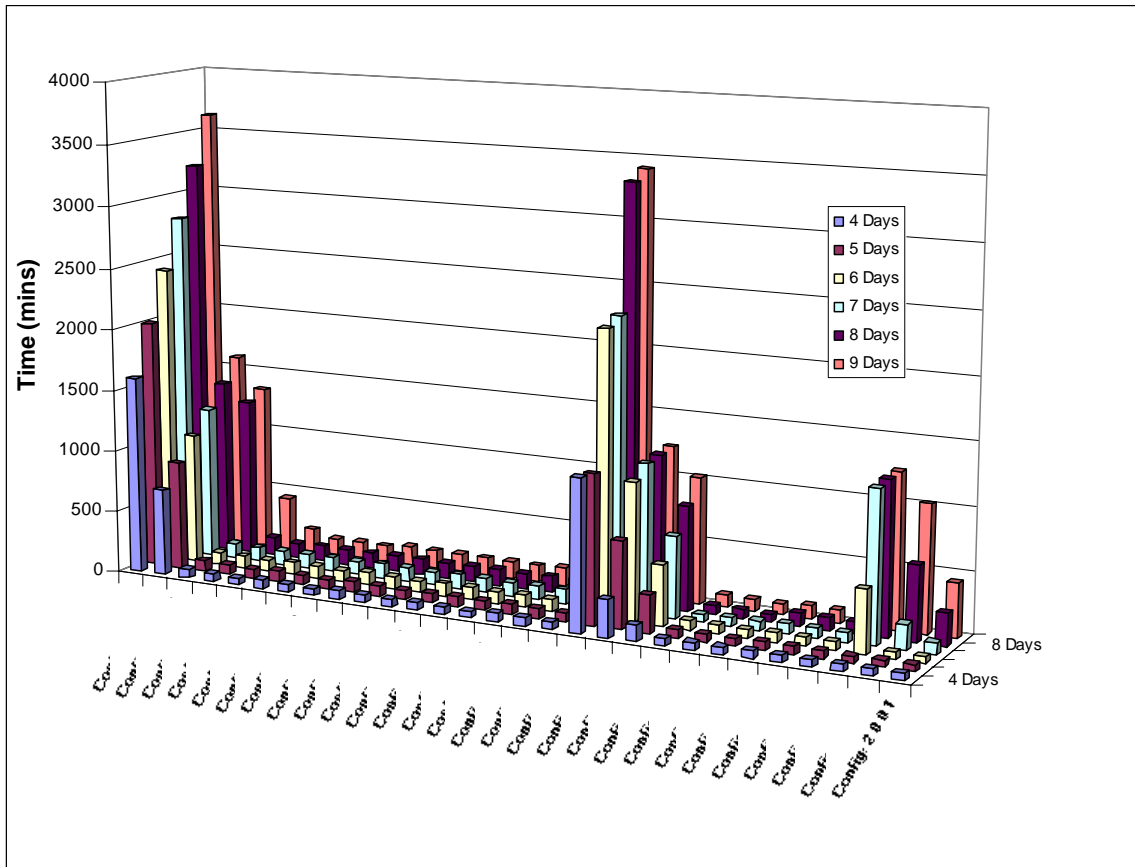

Figure 111. FOB – Supply Ship Presence Duration

The general trend shows an increase of supply ship on-station times for all the configurations from 4 days to 9 days re-supply time. The re-supply times of 4 days vs. 9 days is plotted to further visualize the contrast in the two extreme configurations. Figure 112 plots re-supply times of 4 days vs. 9 days.

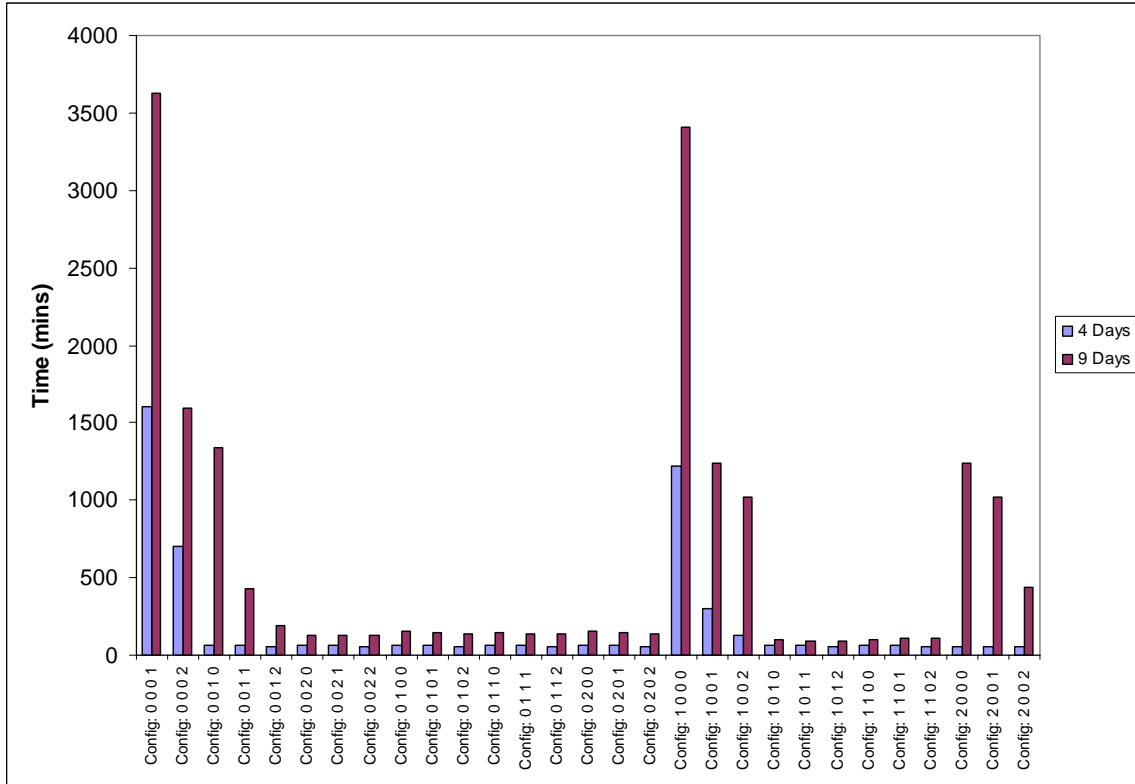

Figure 112. FOB – Supply Ship Presence Duration

From this figure, it is shown that many configurations have nearly the same supply ship on-station time. The connectors that resulted in a low supply ship on-station time required only one run. The connectors that resulted in a high supply ship on-station time required multiple runs. For example, when the number of re-supply days increased to 8 and 9 days, a single LCU-2000 (Config 0010) required an additional run.

The RST chose the configurations that had the least number of platforms while still maintaining a low supply ship on-station time. Configurations with additional platforms did not decrease the duration since the supply load could fit into only one platform. Based on supply ship on-station time, a single Jim G (Config 0100) was the best configuration when the supply ship cycle time varies between 4-9 days. If the cycle time is between 4-7 days, then a single Jim G (Config 0100) and a single LCU-2000 (Config 0010) were the best configurations. Further analysis was done on all of the configurations to measure operating base supply level.

7.1.3.2 Operating Base Supply Level

The Measure of Performance was to maximize operating base supply level. Table 71 was generated for the FOB operating base supply level for clear weather with re-supply varying between 4 and 9 days, and Config: # LCU1610 #Seacor #LCU20000 #Helo.

	4 Days	5 Days	6 Days	7 Days	8 Days	9 Days
Config: 0 0 0 1	382.46	354.37	327.45	299.508	274.72	247.743
Config: 0 0 0 2	402.77	379.76	357.89	335.032	312.60	291.722
Config: 0 0 1 0	402.41	383.25	363.96	344.442	309.15	286.861
Config: 0 0 1 1	404.76	385.09	365.62	345.582	325.45	305.739
Config: 0 0 1 2	406.13	386.55	367.14	346.65	327.07	309.38
Config: 0 0 2 0	402.66	382.94	363.59	343.837	324.19	307.302
Config: 0 0 2 1	405.11	385.24	365.84	345.457	325.15	308.725
Config: 0 0 2 2	406.06	386.07	366.75	346.488	327.17	310.173
Config: 0 1 0 0	401.15	380.71	359.30	338.346	316.90	297.412
Config: 0 1 0 1	404.46	383.31	362.85	340.912	320.11	301.927
Config: 0 1 0 2	405.61	384.81	364.49	342.185	321.55	302.68
Config: 0 1 1 0	401.83	381.51	361.67	340.625	320.17	302.196
Config: 0 1 1 1	404.69	384.00	363.91	343.086	321.65	305.609
Config: 0 1 1 2	406.11	385.69	365.73	344.662	324.06	306.314
Config: 0 2 0 0	401.31	380.56	359.41	337.65	316.29	298.489
Config: 0 2 0 1	404.06	383.40	362.52	342.296	319.80	302.002
Config: 0 2 0 2	405.72	384.68	363.99	342.827	321.47	303.077
Config: 1 0 0 0	408.44	360.58	323.52	300.389	263.71	241.793
Config: 1 0 0 1	417.78	380.99	356.27	332.359	311.64	289.678
Config: 1 0 0 2	419.64	386.65	365.72	344.678	323.97	302.496
Config: 1 0 1 0	416.66	384.05	364.92	345.663	326.54	309.466
Config: 1 0 1 1	418.66	385.46	366.94	348.241	327.63	311.695
Config: 1 0 1 2	420.02	386.72	367.29	348.657	329.59	311.142
Config: 1 1 0 0	416.67	383.30	363.23	342.397	321.36	306.243
Config: 1 1 0 1	418.74	385.37	365.58	344.668	323.55	305.829
Config: 1 1 0 2	419.98	386.54	366.80	345.989	324.39	307.152
Config: 2 0 0 0	402.54	386.13	358.43	329.994	303.90	286.797
Config: 2 0 0 1	419.25	386.87	367.26	347.579	325.15	301.8
Config: 2 0 0 2	406.45	387.46	368.50	348.266	328.99	309.655

Table 71. FOB – Operating Base Supply Level

A three-dimensional visualization of the table is seen in Figure 113.

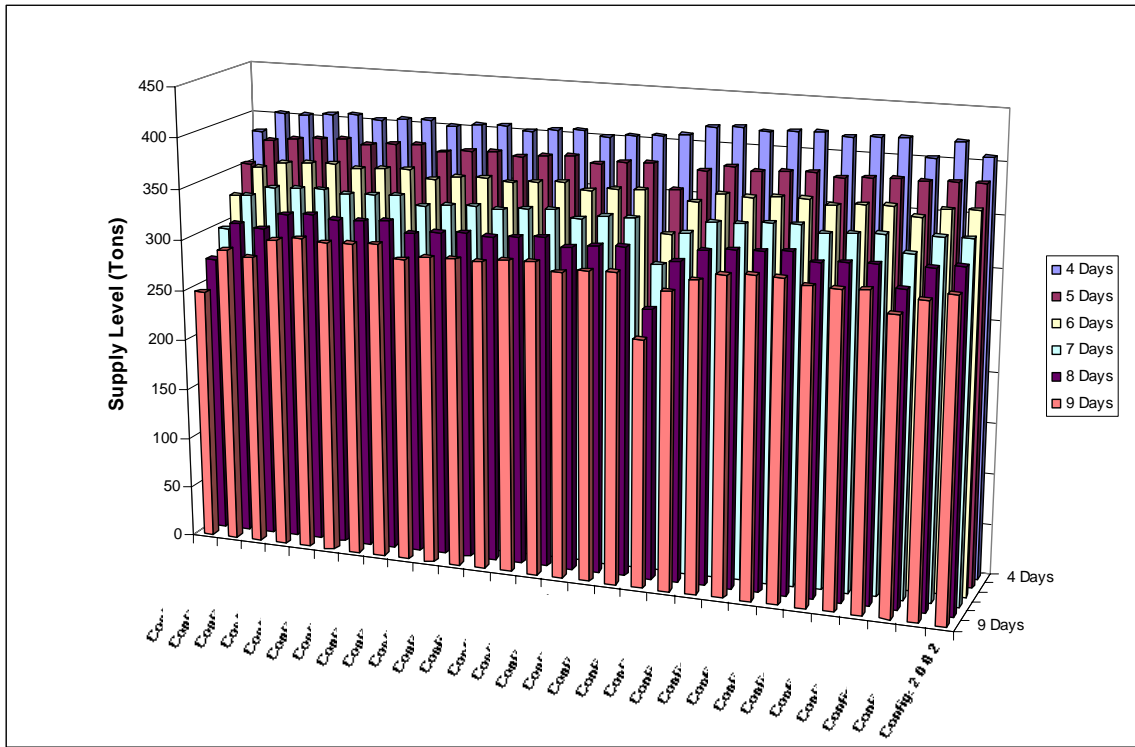

Figure 113. FOB – Operating Base Supply Level

From this figure, it is shown that the operating base supply level decreases as the re-supply days increase from a 4 day rotation to a 9 day rotation. The re-supply times of 4 days vs. 9 days is plotted to further visualize the contrast in the two extreme configurations. Figure 114 plots re-supply times of 4 days vs. 9 days.

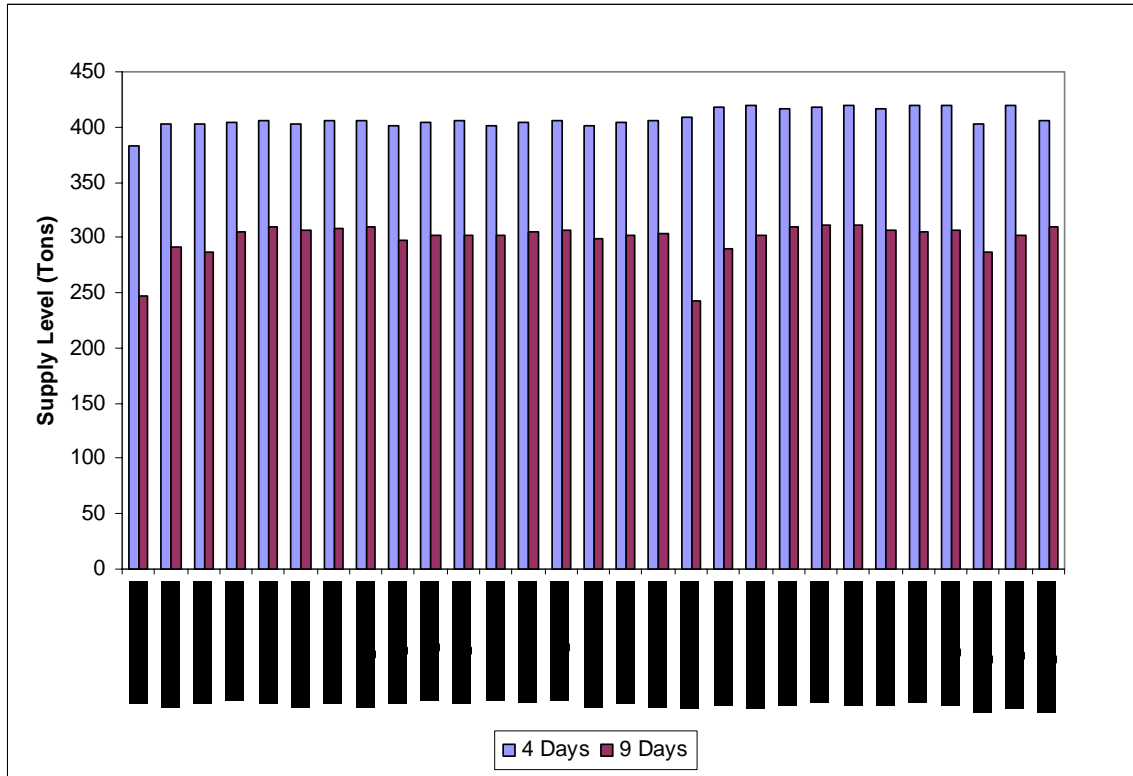

Figure 114. FOB – Operating Base Supply Level

From this figure, it is shown that most of the configurations have nearly the same operating base supply level. Similar to the supply ship on-station time, the RST chose the configurations that had the least number of platforms while still maintaining an adequate operating base supply level. Configurations with additional platforms did not significantly increase the supply level. Based on operating base supply level, a single Jim G (Config 0100) and a single LCU-2000 (Config 0010) were the best configurations.

7.1.3.3 Data Normalization

Although a single LCU-2000 and Jim G were the best configurations to minimize supply ship on-station time and maximize operating base supply level, the RST still analyzed the other configurations' performance in both categories. Data was normalized to combine both supply ship presence duration and operating base supply level into one score.

The RST normalized the supply ship on-station time data by scoring 0 hours as 1.0 and 24 hours as 0. Operating base supply level was normalized by getting the percent of the 15 day supply level. The RST took the average performance of the different configurations when the supply ship cycle time was between four and seven days and again when the time was between eight and nine days.

The RST assumed that the weighting is 0.6 for operating supply level and 0.4 for supply ship on-station time. Operating supply level was weighted more because the supply level greatly impacts the RF operation. Table 72 shows the utility score for each configuration, where Config: # LCU1610 #Seacor #LCU20000 #Helo.

	4 to 7 Days	8 to 9 Days
Config: 0 0 0 1	0.198	0.000
Config: 0 0 0 2	0.578	0.349
Config: 0 0 1 0	0.827	0.399
Config: 0 0 1 1	0.830	0.703
Config: 0 0 1 2	0.834	0.742
Config: 0 0 2 0	0.827	0.746
Config: 0 0 2 1	0.831	0.748
Config: 0 0 2 2	0.833	0.751
Config: 0 1 0 0	0.823	0.733
Config: 0 1 0 1	0.828	0.739
Config: 0 1 0 2	0.831	0.741
Config: 0 1 1 0	0.824	0.739
Config: 0 1 1 1	0.829	0.743
Config: 0 1 1 2	0.832	0.746
Config: 0 2 0 0	0.822	0.733
Config: 0 2 0 1	0.828	0.739
Config: 0 2 0 2	0.831	0.742
Config: 1 0 0 0	0.334	0.000
Config: 1 0 0 1	0.621	0.423
Config: 1 0 0 2	0.750	0.521
Config: 1 0 1 0	0.839	0.761
Config: 1 0 1 1	0.842	0.764
Config: 1 0 1 2	0.843	0.766
Config: 1 1 0 0	0.836	0.751
Config: 1 1 0 1	0.839	0.752
Config: 1 1 0 2	0.841	0.754
Config: 2 0 0 0	0.721	0.414
Config: 2 0 0 1	0.835	0.554
Config: 2 0 0 2	0.840	0.690

Table 72. FOB Supply Level Utility Score for Configurations

As shown in Table 72, many of the configurations performed the same. Only some configurations were clearly dominated, but no configuration was significantly the best based on utility score alone. When looking at the configurations that resulted in a score greater than 0.8 in four to seven days or 0.7 in eight to nine days, additional platforms did very little to the performance. This knowledge helped the RST calculate the efficiency of the different configurations.

7.1.3.4 Cost Performance

Cost performance graphs were compiled by plotting the cost of the configuration and the utility score. Helicopters add very little to the overall performance but significantly increase the cost. In order to reduce the number of data points, the RST screened out configurations with helicopters as well as some configurations that were clearly inefficient by evaluating single platforms first and then seeing how additional platforms affected the score. Figure 115 is a cost performance curve for the screened configurations.

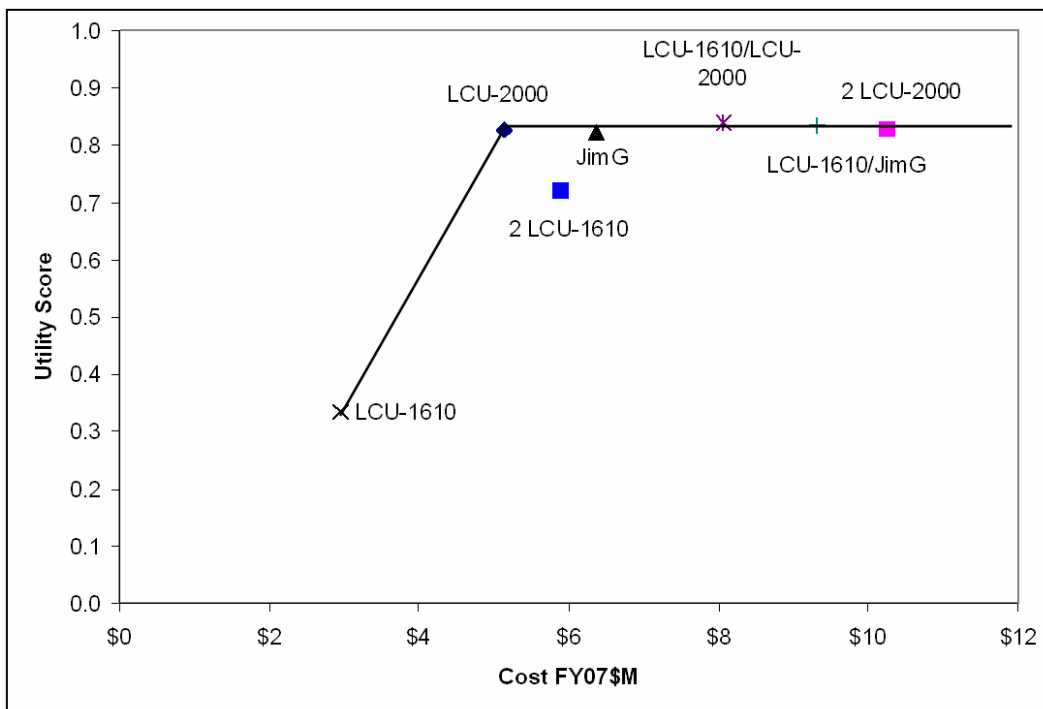

Figure 115. Connector Alternatives Cost Performance Curve for FOB 4-7 Days.

Figure 115 shows that one LCU-2000 (Config 0010) was the most cost effective configuration. Adding an LCU-1610 with the LCU-2000 (Config 1010) did very little to performance but added to the cost.

The same strategy was implemented for the supply ship cycle between eight and nine days. Figure 116 is a cost performance curve for the screened alternatives.

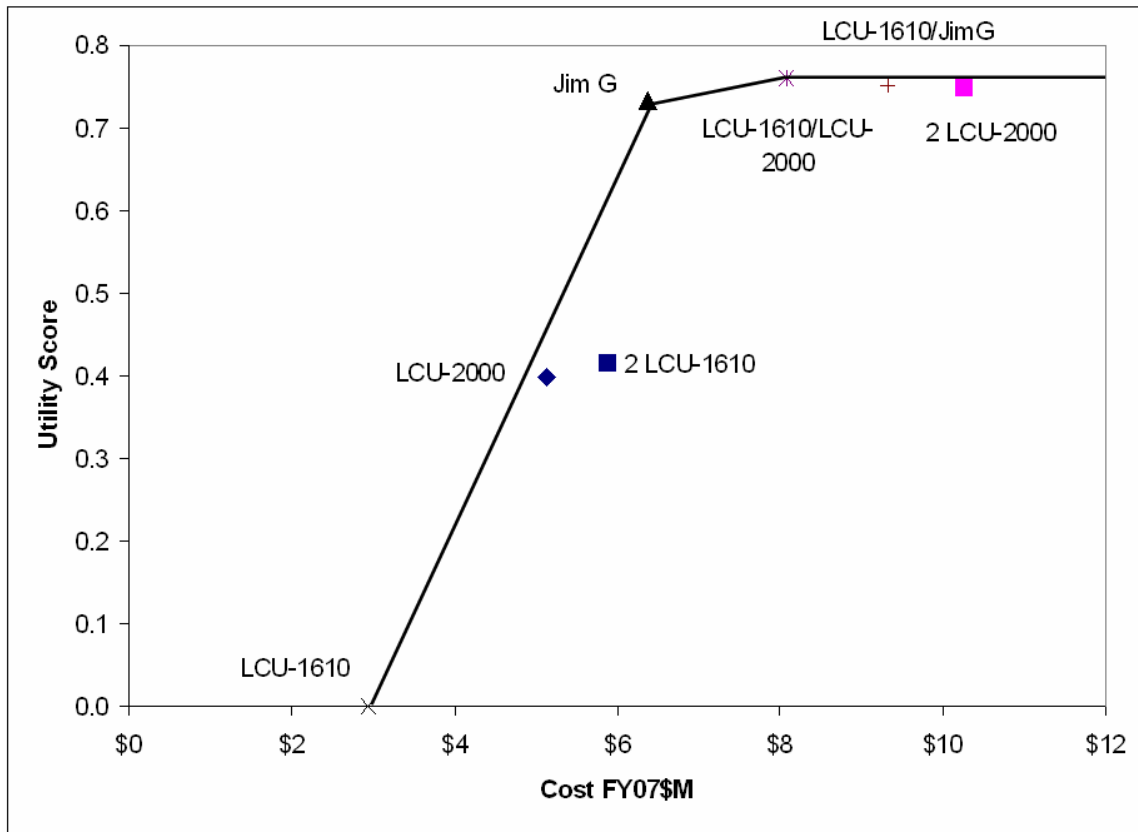

Figure 116. Connector Alternatives Cost Performance Curve for FOB 8-9 Days.

From Figure 116., the LCU-2000 decreased in performance due to the increase in supply level. The Jim G remained at a decent score, but the LCU-1610 and LCU-2000 configuration (Config 1010) performed better with an increased cost. With the performance so close, the Jim G may be the most cost effective configuration.

7.1.4 SIMKIT Analysis of MOB1

The Nobriza+Barge combination was MOB1.

7.1.4.1 Supply Ship On-Station Time

The Measure of Performance was to minimize supply ship presence duration for MOB1. Table 73 was generated for the MOB1 supply ship presence duration for clear weather with re-supply varying between 4 and 9 days, and Config: #LCU1610 #Seacor #LCU20000 #Helo.

	4 Days	5 Days	6 Days	7 Days	8 Days	9 Days
Config: 0 0 0 1	1754.41	2195.74	2636.04	3067.73	3492.91	3937.01
Config: 0 0 0 2	753.25	947.472	1144.04	1335.55	1520.76	1717.48
Config: 0 0 1 0	72.39	90.0902	108.184	929.72	1331.59	1351.76
Config: 0 0 1 1	67.24	85.1604	102.996	121.27	274.11	688.296
Config: 0 0 1 2	62.34	80.1748	97.9105	115.94	141.24	296.293
Config: 0 0 2 0	72.48	90.192	108.012	125.61	131.00	131
Config: 0 0 2 1	67.41	85.1186	102.959	121.02	130.77	131
Config: 0 0 2 2	62.42	80.1115	98.2386	115.94	129.79	131
Config: 0 1 0 0	72.53	90.316	108.104	126.23	143.88	1240.19
Config: 0 1 0 1	67.36	85.249	102.9	120.78	138.88	156.856
Config: 0 1 0 2	62.38	80.1352	97.9197	116.17	133.35	151.367
Config: 0 1 1 0	72.30	90.1922	108.212	125.49	137.56	146.255
Config: 0 1 1 1	67.23	85.3101	102.876	120.63	134.80	143.904
Config: 0 1 1 2	62.26	80.0721	98.0309	115.89	131.55	141.698
Config: 0 2 0 0	72.38	90.3347	108.252	125.77	143.99	160.917
Config: 0 2 0 1	67.28	85.0368	103.097	120.87	138.67	156.353
Config: 0 2 0 2	62.25	79.9521	97.9158	115.96	133.94	4548.47
Config: 1 0 0 0	1184.98	2133.72	2309.89	2847.16	3410.36	3602.74
Config: 1 0 0 1	414.57	860.395	1189.04	1211.12	1228.96	1320.31
Config: 1 0 0 2	169.85	363.399	561.152	754.56	940.17	1131.68
Config: 1 0 1 0	62.98	71.4387	70.4093	72.14	90.08	108.194
Config: 1 0 1 1	60.59	69.1278	75.3231	67.04	85.09	102.806
Config: 1 0 1 2	57.97	66.6971	75.0282	64.53	80.17	97.7385
Config: 1 1 0 0	63.06	71.4171	81.0116	98.35	108.42	107.831
Config: 1 1 0 1	60.63	68.9741	77.6794	92.91	108.38	104.594
Config: 1 1 0 2	58.12	66.5514	75.2735	87.88	105.94	103.396
Config: 2 0 0 0	54.00	54	1161.34	1223.46	1240.92	1244.31
Config: 2 0 0 1	54.00	54	64.9645	412.47	855.26	1174.72
Config: 2 0 0 2	54.00	54	54.1694	169.55	360.27	553.325

Table 73. MOB1 – Supply Ship Presence Duration

A three-dimensional visualization of the table is seen in Figure 117.

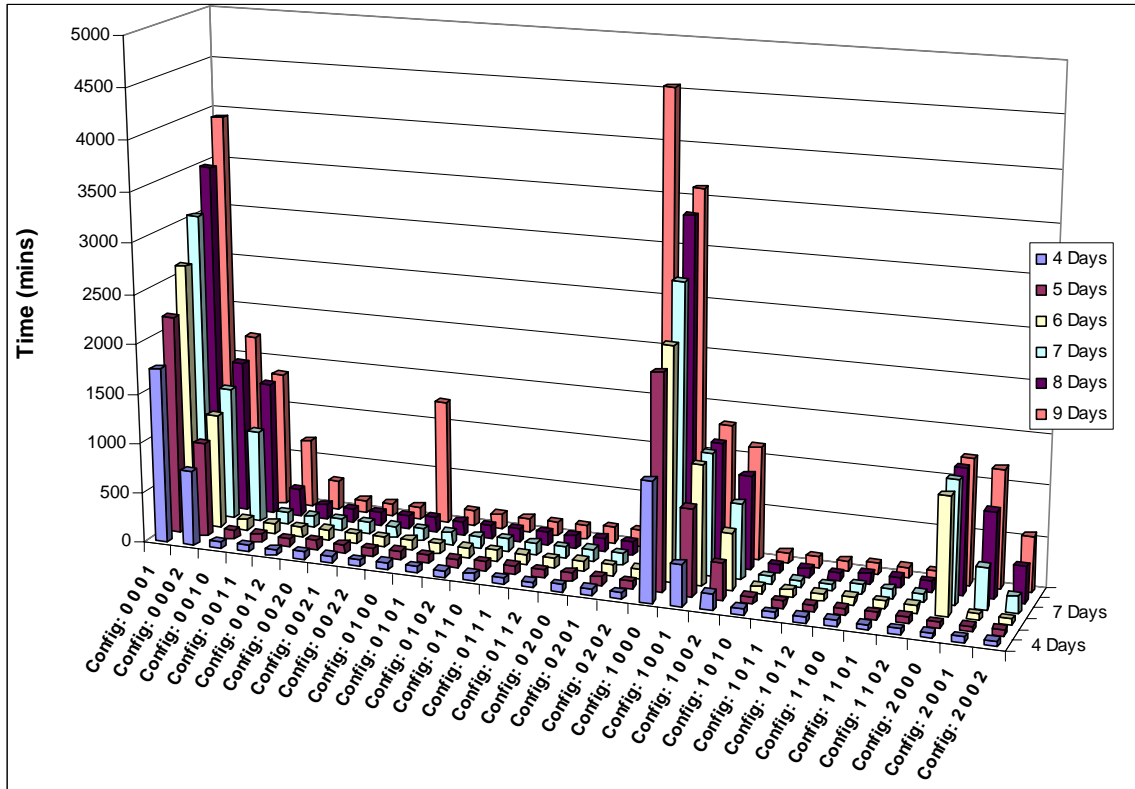

Figure 117. MOB1 – Supply Ship Presence Duration

The general trend shows an increase of supply ship on-station time for all the configurations from 4 days to 9 days re-supply time. The re-supply times of 4 days vs. 9 days is plotted to further visualize the contrast in the two extreme configurations. Figure 118 plots re-supply times of 4 days vs. 9 days.

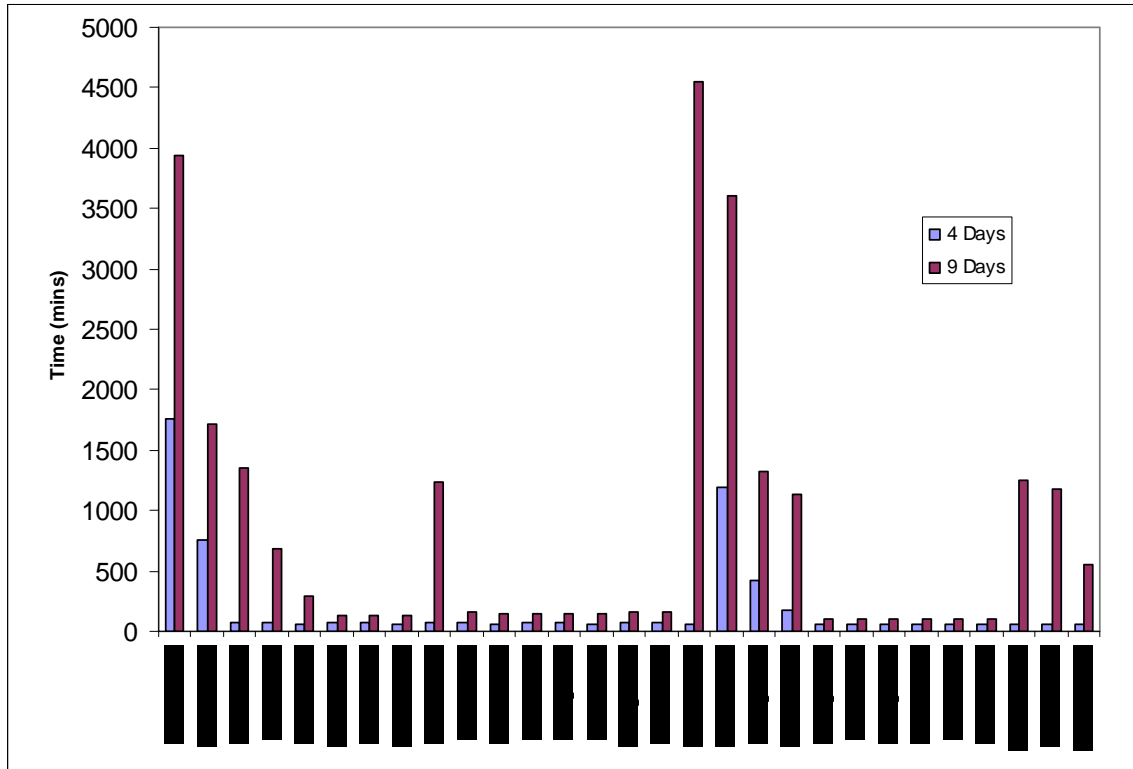

Figure 118. MOB1 – Supply Ship Presence Duration

From this figure, it is shown that many configurations have nearly the same supply ship on-station time. The connectors that resulted in a low supply ship on-station time required only one run. The connectors that resulted in a high supply ship on-station time required multiple runs. For example, when the number of re-supply days increased to nine days, a single Jim G required an additional run.

The RST chose the configurations that had the least number of platforms while still maintaining a low supply ship presence duration. Configurations with additional platforms did not decrease the duration since the supply load could fit in one platform. Based on supply ship presence duration, a single Jim G (Config 0100) and a single LCU-2000 (Config 0010) were the best configuration when the supply ship cycle time varies between 4-7 days. If the cycle time is between 8-9 days, then configurations with at least one Jim G or one LCU-2000 along with another vessel is a good

configuration. Further analysis was done on all of the configurations to measure operating base supply level.

7.1.4.2 Operating Base Supply Level

The Measure of Performance was to maximize operating base supply level for MOB1. Table 74 was generated for the MOB1 operating base supply level for clear weather with re-supply varying between 4 and 9 days, and Config: # LCU1610 #Seacor #LCU20000 #Helo.

	4 Days	5 Days	6 Days	7 Days	8 Days	9 Days
Config: 0 0 0 1	405.158	375.013	343.935	315.33	286.125	256.458
Config: 0 0 0 2	429.629	404.458	380.138	356.533	331.716	309.477
Config: 0 0 1 0	429.948	409.48	388.237	356.038	327.472	303.542
Config: 0 0 1 1	432.575	411.565	390.507	368.572	348.124	325.225
Config: 0 0 1 2	433.529	412.421	391.714	369.988	348.904	330.408
Config: 0 0 2 0	429.757	409.044	388.419	366.821	346.502	329.39
Config: 0 0 2 1	432.271	411.554	390.505	368.74	347.513	331.287
Config: 0 0 2 2	433.324	412.243	391.194	369.641	348.122	331.363
Config: 0 1 0 0	428.043	405.58	383.092	359.715	336.97	301.951
Config: 0 1 0 1	431.287	408.64	386.773	363.614	340.345	319.897
Config: 0 1 0 2	432.864	410.063	387.825	364.046	342.23	321.735
Config: 0 1 1 0	429.168	407.246	385.351	363.355	340.852	323.574
Config: 0 1 1 1	431.942	409.958	388.839	366.325	344.08	325.71
Config: 0 1 1 2	433.494	411.395	389.826	367.134	345.419	326.003
Config: 0 2 0 0	428.177	405.434	383.257	360.215	337.121	316.874
Config: 0 2 0 1	431.474	409.1	386.11	363.598	340.786	320.321
Config: 0 2 0 2	432.983	410.609	388.39	364.485	342.031	322.076
Config: 1 0 0 0	407.143	368.973	342.637	310.645	278.336	253.33
Config: 1 0 0 1	430.636	403.662	377.88	354.015	330.759	308.863
Config: 1 0 0 2	434.156	412.713	390.019	367.44	345.479	320.562
Config: 1 0 1 0	430.812	410.283	389.914	370.688	348.869	329.966
Config: 1 0 1 1	432.785	412.119	392.083	372.499	350.453	332.404
Config: 1 0 1 2	433.951	412.84	392.766	373.314	351.162	332.437
Config: 1 1 0 0	430.738	409.506	387.904	364.892	343.551	326.583
Config: 1 1 0 1	432.52	411.492	389.737	368.084	345.702	328.554
Config: 1 1 0 2	433.635	412.506	390.996	369.286	345.154	329.985
Config: 2 0 0 0	430.914	411.884	375.022	349.065	326.581	304.681
Config: 2 0 0 1	433.165	413.279	392.502	370.427	343.815	318.124
Config: 2 0 0 2	434.294	413.976	393.775	372.344	352.137	328.36

Table 74. MOB1 – Operating Base Supply Level

A three-dimensional visualization of the table is seen in Figure 119.

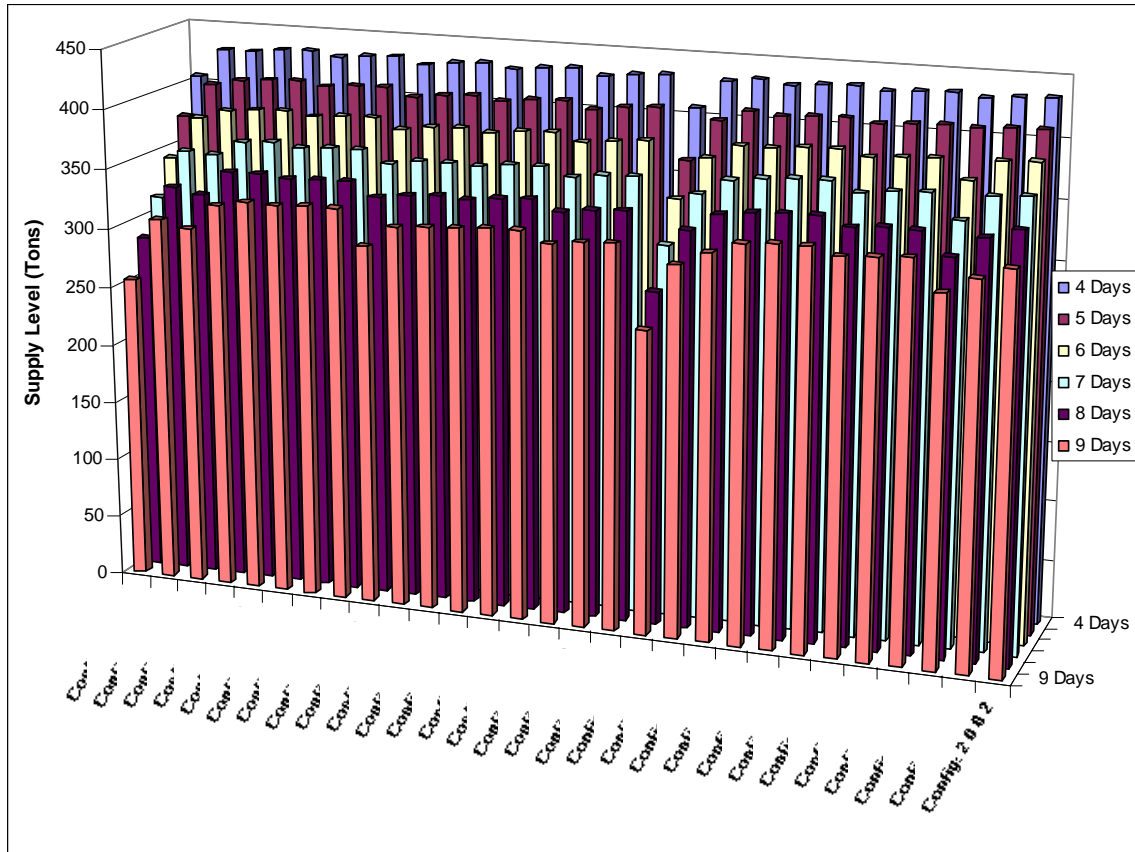

Figure 119. MOB1 – Operating Base Supply Level

From this figure, it is shown that the operating base supply level decreases as re-supply days increase from a 4 day rotation to a 9 day rotation. The re-supply times of 4 days vs. 9 days is plotted to further visualize the contrast in the two optimal extreme configurations. Figure 120 plots re-supply times of 4 days vs. 9 days.

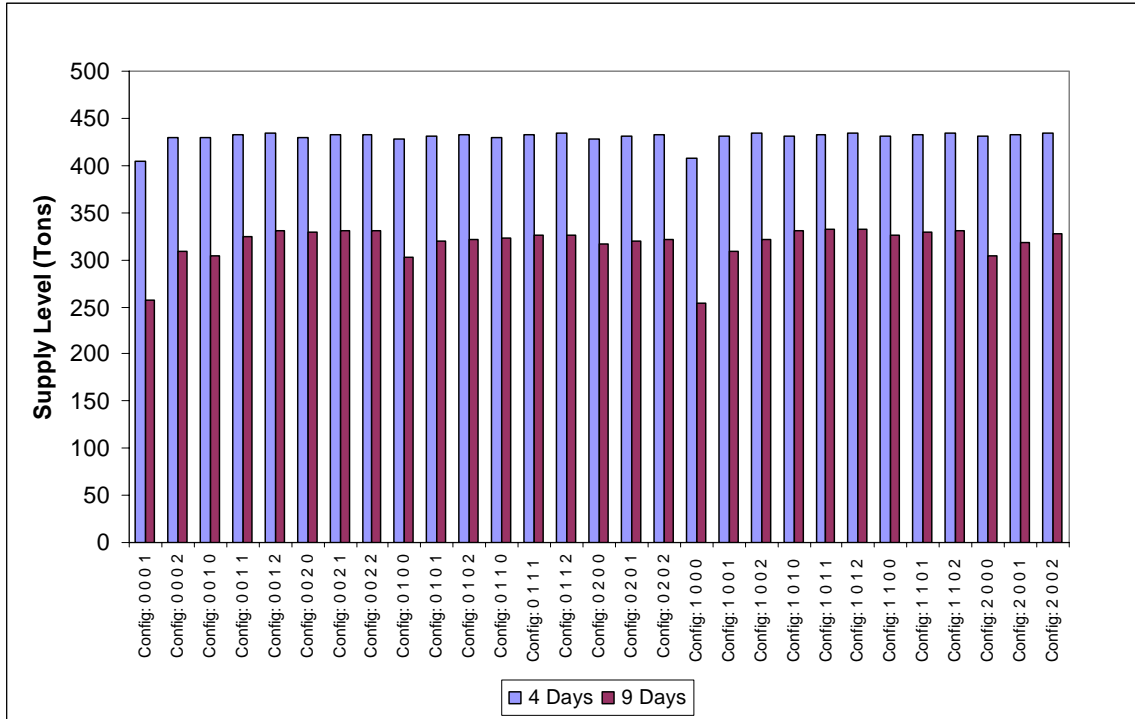

Figure 120. MOB1 – Operating Base Supply Level

From this figure, it is shown that most of the configurations have nearly the same operating base supply level. Similar to supply ship on-station time measurement, the RST chose the configurations that had the least number of platforms while still maintaining an adequate operating base supply level. Configurations with additional platforms did not significantly increase the supply level. Based on operating base supply level, a single Jim G (Config 0100) and a single LCU-2000 (Config 0010) were the best configurations.

7.1.4.3 Data Normalization

Although a single LCU-2000 and Jim G were the best configurations to minimize the supply ship presence duration and maximize operating base supply level, the RST still analyzed the other configurations' performance in both categories. Data

was normalized to combine both supply ship on-station time and operating base supply level into one score.

The RST normalized the supply ship on-station time data by scoring 0 hours as 1.0 and 24 hours as 0. Operating base supply level was normalized by getting the percent of the 15 day supply level. The RST took the average performance of the different configurations when the supply ship cycle time was between four and seven days and again when the time was between eight and nine days.

The RST assumed that the weighting is 0.6 for operating supply level and 0.4 for supply ship on-station time. Operating supply level was weighted more because the supply level greatly impacts the RF operation. Table 75 shows the utility score for each configuration, where Config: # LCU1610 #Seacor #LCU20000 #Helo.

	4 to 7 Days	8 to 9 Days
Config: 0 0 0 1	0.138	-0.324
Config: 0 0 0 2	0.555	0.314
Config: 0 0 1 0	0.766	0.385
Config: 0 0 1 1	0.828	0.648
Config: 0 0 1 2	0.831	0.724
Config: 0 0 2 0	0.824	0.747
Config: 0 0 2 1	0.828	0.749
Config: 0 0 2 2	0.831	0.749
Config: 0 1 0 0	0.819	0.570
Config: 0 1 0 1	0.825	0.733
Config: 0 1 0 2	0.827	0.737
Config: 0 1 1 0	0.822	0.737
Config: 0 1 1 1	0.827	0.741
Config: 0 1 1 2	0.829	0.743
Config: 0 2 0 0	0.820	0.729
Config: 0 2 0 1	0.825	0.734
Config: 0 2 0 2	0.828	0.126
Config: 1 0 0 0	0.217	-0.273
Config: 1 0 0 1	0.589	0.409
Config: 1 0 0 2	0.727	0.490
Config: 1 0 1 0	0.835	0.757
Config: 1 0 1 1	0.837	0.761
Config: 1 0 1 2	0.839	0.763
Config: 1 1 0 0	0.830	0.750
Config: 1 1 0 1	0.833	0.753
Config: 1 1 0 2	0.836	0.754
Config: 2 0 0 0	0.671	0.413
Config: 2 0 0 1	0.816	0.493
Config: 2 0 0 2	0.835	0.659

Table 75. MOB1 Supply Level Utility Score for Configurations

As shown in Table 75, many of the configurations performed the same. Only some configurations were clearly dominated, but no configuration was significantly the best based on utility score alone. When looking at the configurations that resulted in a score greater than 0.8 in four to seven days or 0.7 in eight to nine days, additional platforms did very little to the performance. This knowledge helped the RST calculate the efficiency of the different configurations.

7.1.4.4 Cost Performance

Cost performance graphs were compiled by plotting the cost of the configuration and the utility score. Similar to the FOB, helicopters added very little to

the overall performance but significantly increase the cost. In order to reduce the number of data points, the RST screened out configurations with helicopters as well as some configurations that were clearly inefficient by evaluating single platforms first and then seeing how additional platforms affected the score. Figure 121 is a cost performance curve for the screened configurations for 4-7 days.

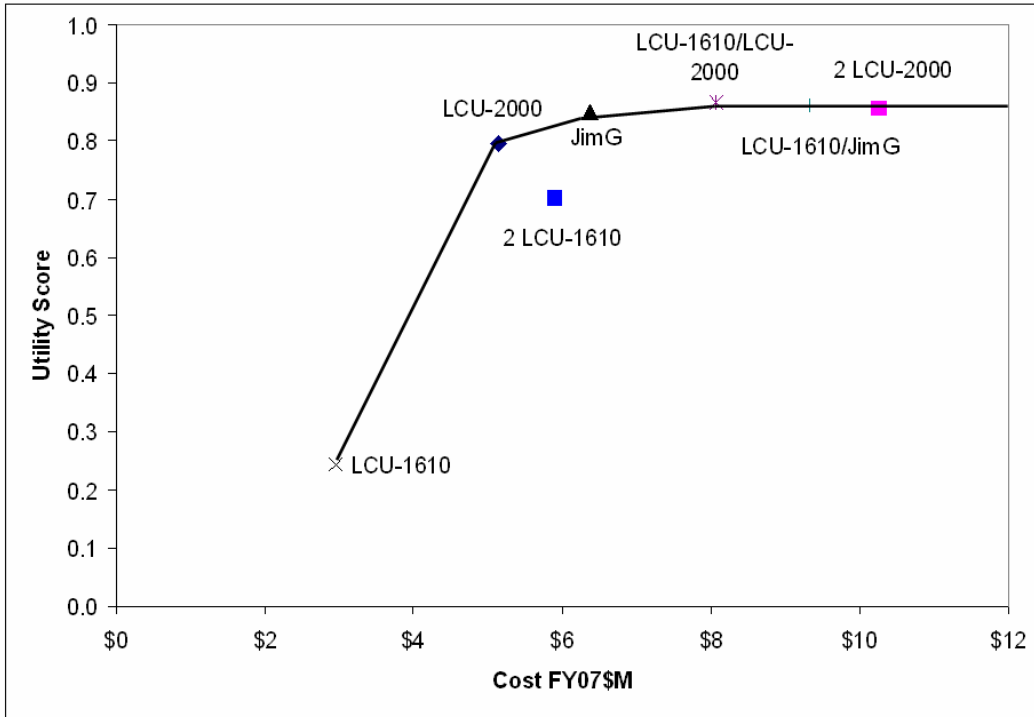

Figure 121. Connector Alternatives Cost Performance Curve for MOB1 4-7 Days.

Figure 121 shows that one LCU-2000 (Config 0010) was the most cost effective configuration. Adding an LCU-1610 with the LCU-2000 (Config 1010) or choosing a Jim G (Config 0100) instead of an LCU-2000 did very little to performance but added a lot to the cost.

The same strategy was implemented for the supply ship cycle between eight and nine days. Figure 122 is a cost performance curve for the screened alternatives.

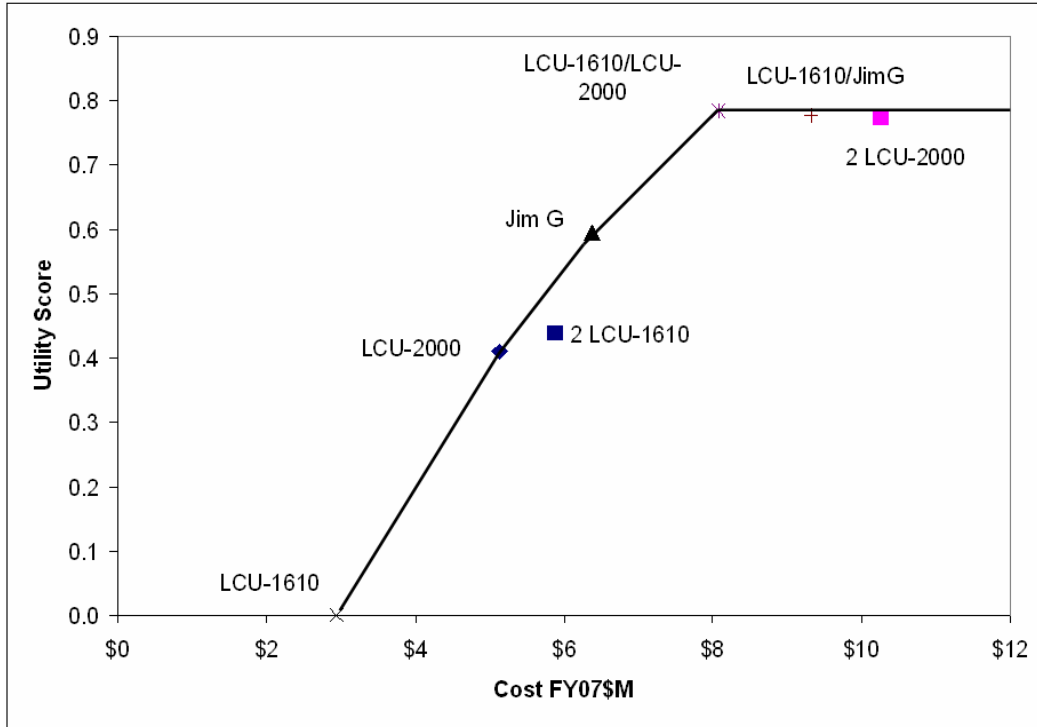

Figure 122. Connector Alternatives Cost Performance Curve for MOB1 8-9 Days.

From Figure 122., the LCU-2000 and the Jim G decreased in performance due to the increase in supply level. The LCU-1610 and LCU-2000 configuration (Config 1010) performed the best. Because of the decreased performance of the Jim G, the RST recommended an LCU-1610 and LCU-2000 as the most cost effective configuration.

7.1.5 SIMKIT Analysis of MOB2

The RCSS, RSS-207 Endurance, and KD-1505 Sri Inderapura were MOB2

7.1.5.1 Supply Ship On-Station Time

The Measure of Performance was to minimize supply ship presence duration for MOB2. Table 76 was generated for the average MOB2 supply ship presence

duration based on three positions for clear weather with re-supply varying between 4 and 9 days, and Config: # LCU1610 #Seacor #LCU20000 #Helo.

	4 Days	5 Days	6 Days	7 Days	8 Days	9 Days
Config: 0 0 0 1	3253.10	4060.25	4849.46	5636.09	6400.37	7150.13
Config: 0 0 0 2	1268.48	1588.55	1911.47	2229.89	2544.94	2865.45
Config: 0 1 0 0	112.28	139.82	1245.34	1303.76	1331.29	1359.06
Config: 0 1 0 1	106.97	134.71	169.47	747.09	1226.04	1291.66
Config: 0 1 0 2	101.89	129.78	157.03	287.45	604.24	917.63
Config: 0 2 0 0	112.21	139.98	163.96	166.00	166.00	166.00
Config: 0 2 0 1	107.04	134.76	161.18	166.00	166.00	166.00
Config: 0 2 0 2	101.97	129.76	157.42	166.00	166.00	166.00
Config: 1 0 0 0	1760.86	2247.43	2638.72	3237.14	3744.31	4289.45
Config: 1 0 0 1	752.08	966.89	1235.74	1498.02	1753.28	1878.68
Config: 1 0 0 2	545.29	673.55	841.24	1010.61	1109.95	1260.35
Config: 1 1 0 0	67.83	93.69	113.32	141.56	667.93	839.73
Config: 1 1 0 1	66.83	89.43	108.49	136.15	186.02	579.13
Config: 1 1 0 2	67.84	84.49	104.10	131.12	159.11	306.19
Config: 2 0 0 0	732.69	766.40	775.86	1180.06	1468.92	1493.94
Config: 2 0 0 1	101.91	625.23	753.45	772.33	780.42	986.78
Config: 2 0 0 2	61.39	335.41	551.19	678.40	758.21	773.91

Table 76. MOB2 – Supply Ship Presence Duration

A three-dimensional visualization of the table is seen in Figure 123.

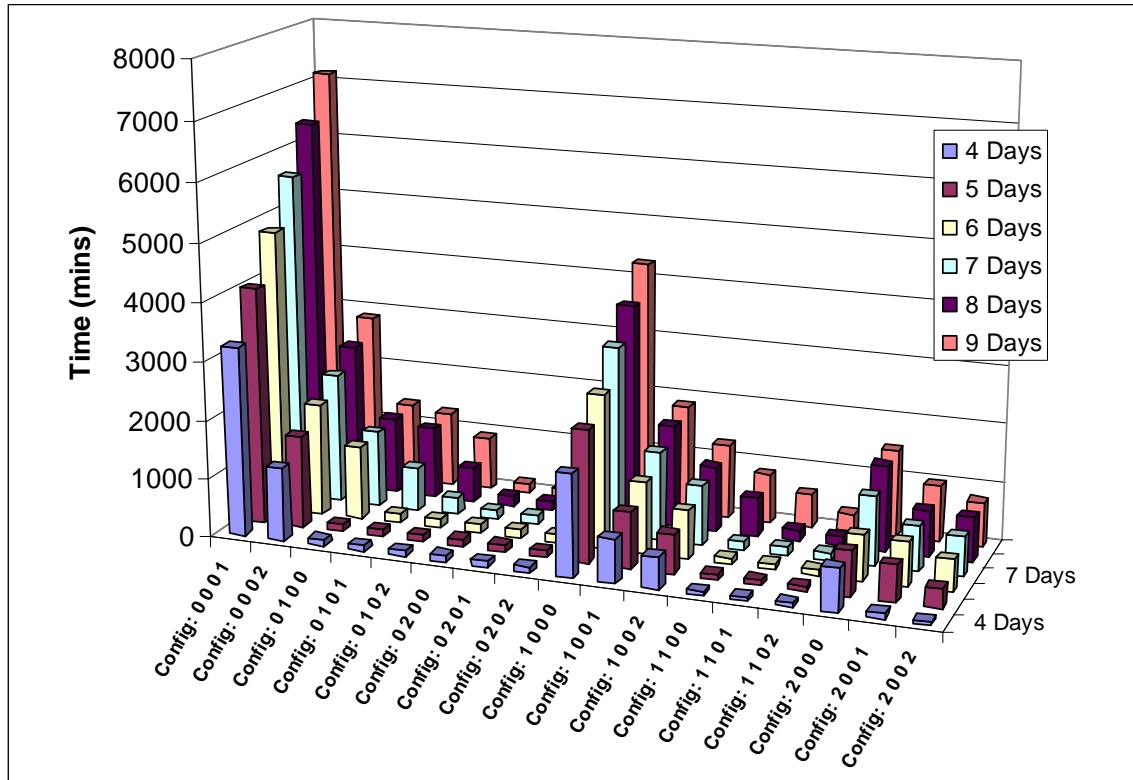

Figure 123. MOB2 – Supply Ship Presence Duration

The general trend shows an increase of the supply ship on-station time for all the configurations from 4 days to 9 days re-supply time. The re-supply times of 4 days vs. 9 days is plotted to further visualize the contrast in the two extreme configurations.

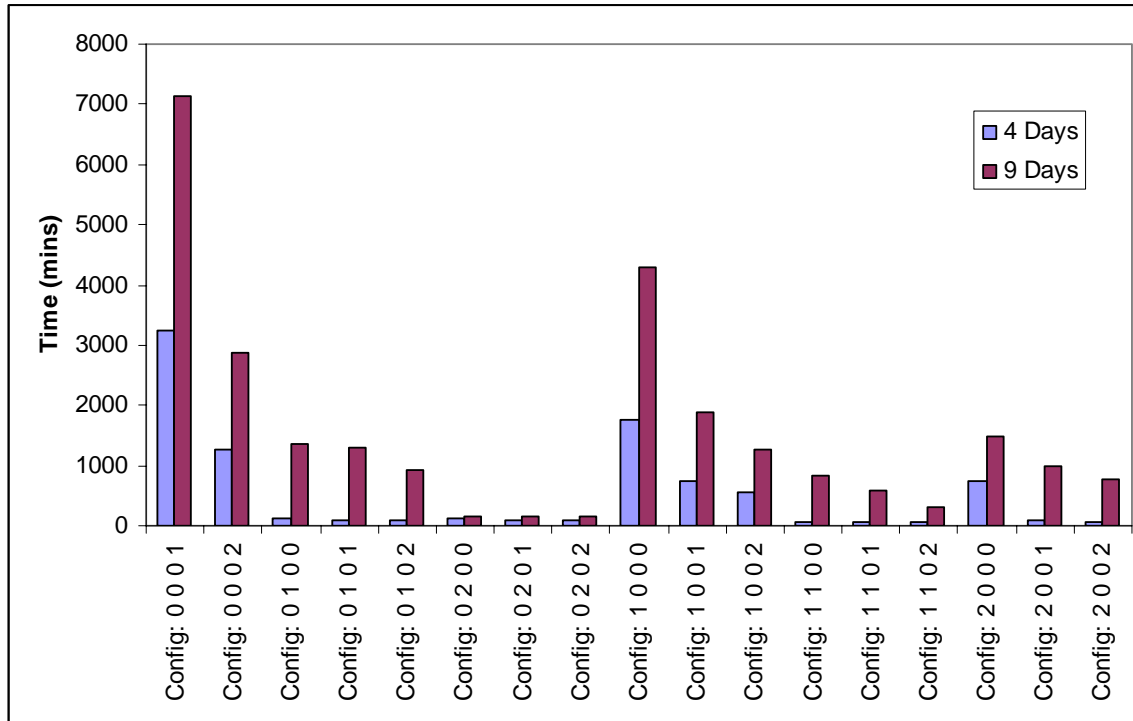

Figure 124. MOB2 - Supply Ship Presence Duration

From Figure 124, it is shown that most configurations have the same supply ship on-station time for four days. The connectors that resulted in a low supply ship on-station times required only one run. The connectors that resulted in a high supply ship on-station times required multiple runs. For example, when the number of re-supply days increased to nine days, a single Jim G required an additional run.

The RST chose the configurations that had the least number of platforms while still maintaining a low supply ship presence duration. Configurations with additional platforms did not decrease the duration since the supply load could fit in one or two platforms. Based on supply ship presence duration, two Jim G's (Config 0200) and a LCU-1610 and Jim G, (Config 1100) were the best configuration when the supply ship cycle time varies between 4-7 days. If the cycle time is between 8-9 days, then two Jim were the best configuration. Further analysis was done on all of the configurations to measure operating base supply level.

7.1.5.2 Operating Base Supply Level

The Measure of Performance was to maximize operating base supply level for MOB2. Table 77 was generated for the average MOB2 operating base supply level for clear weather with re-supply varying between 4 and 9 days, and Config: # LCU1610 #Seacor #LCU20000 #Helo.

	4 Days	5 Days	6 Days	7 Days	8 Days	9 Days
Config: 0 0 0 1	570.64	509.24	452.47	394.33	338.77	276.21
Config: 0 0 0 2	619.75	571.55	523.09	474.63	430.61	380.90
Config: 0 1 0 0	656.05	617.10	567.02	528.46	493.11	454.92
Config: 0 1 0 1	661.76	624.95	578.10	539.31	504.81	468.43
Config: 0 1 0 2	664.96	627.68	591.30	557.46	519.31	485.42
Config: 0 2 0 0	661.53	623.90	589.14	559.93	528.39	499.32
Config: 0 2 0 1	661.74	624.50	589.09	559.96	529.89	503.14
Config: 0 2 0 2	664.82	627.86	591.36	560.47	531.81	504.40
Config: 1 0 0 0	652.78	612.62	573.09	533.76	497.64	461.09
Config: 1 0 0 1	629.83	581.61	536.75	491.65	441.92	397.47
Config: 1 0 0 2	661.52	625.68	586.79	545.63	510.05	474.51
Config: 1 1 0 0	672.51	635.75	599.00	561.81	524.16	489.19
Config: 1 1 0 1	671.85	637.44	604.43	567.60	525.19	488.79
Config: 1 1 0 2	673.17	639.39	606.24	569.58	533.56	500.67
Config: 2 0 0 0	668.63	633.52	601.57	567.03	528.03	495.72
Config: 2 0 0 1	665.67	626.01	591.44	549.80	516.78	480.06
Config: 2 0 0 2	676.87	638.25	600.00	565.58	531.67	497.46

Table 77. MOB2 – Operating Base Supply Level

A three-dimensional visualization of the table is seen in Figure 125.

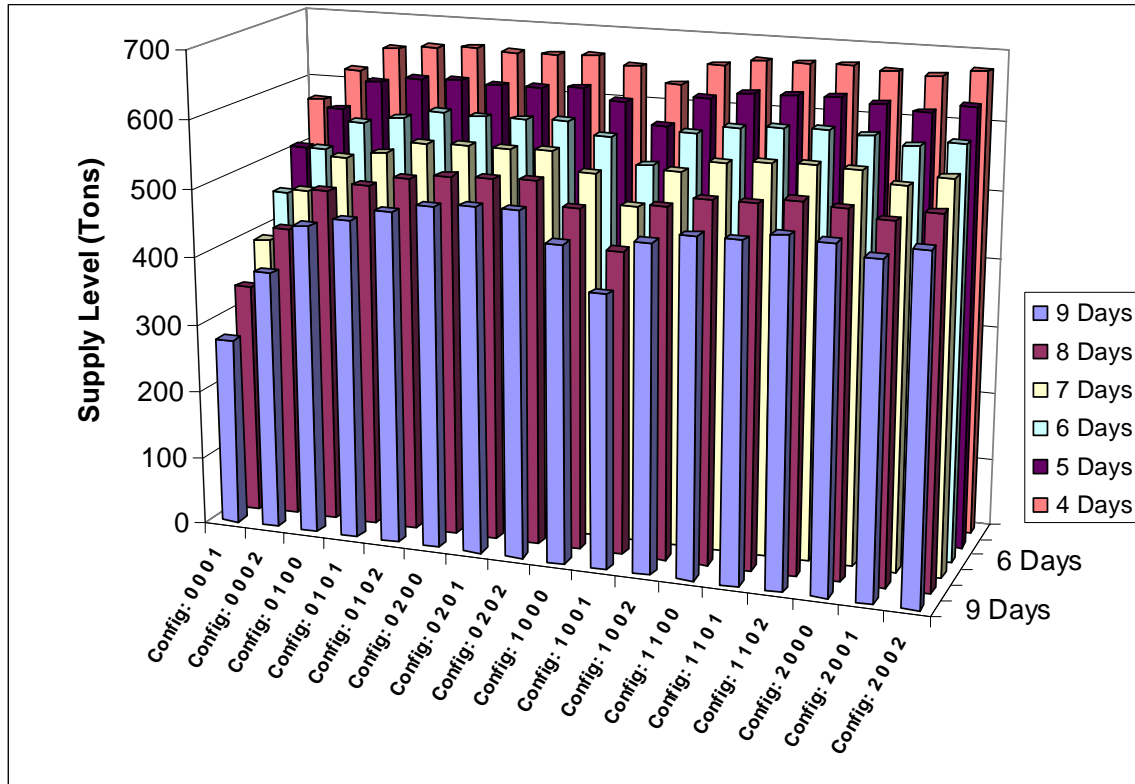

Figure 125. MOB2 – Operating Base Supply Level

From this figure, it is shown that the operating base supply level decreases as re-supply days increase from a 4 day rotation to a 9 day rotation. The re-supply times of 4 days vs. 9 days is plotted to further visualize the contrast in the two optimal extreme configurations. Figure 126 plots re-supply times of 4 days vs. 9 days.

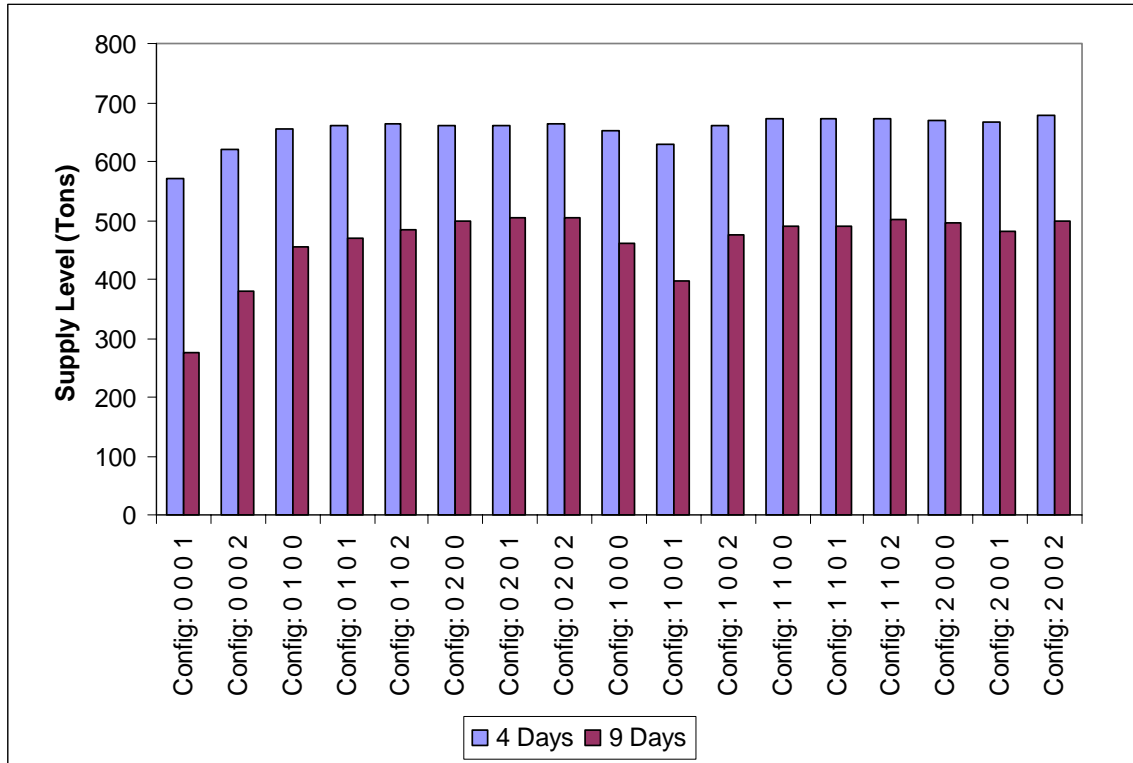

Figure 126. MOB2 – Operating Base Supply Level

From Figure 126, it is shown that most of the configurations have nearly the same operating base supply level. Similar to the supply ship on-station time measurement, the RST chose the configurations that had the least number of platforms while still maintaining an adequate operating base supply level. Configurations with additional platforms did not significantly increase the supply level. Based on operating base supply level, a single Jim G (Config 0100) was the best configurations.

7.1.5.3 Data Normalization

The RST analyzed the performance of all configurations in both categories. Data was normalized to combine both supply ship on-station time and operating base supply level into one score.

The RST normalized the supply ship presence duration data by scoring 0 hours as 1.0 and 24 hours as 0. Operating base supply level was normalized by getting

the percent of the 15 day supply level. The RST took the average performance of the different configurations when the supply ship cycle time was between four and seven days and again when the time was between eight and nine days.

The RST assumed that the weighting is 0.6 for operating supply level and 0.4 for supply ship on-station times. Operating supply level was weighted more because the supply level greatly impacts the RF operation. Table 78 shows the utility score for each configuration, where Config: # LCU1610 #Seacor #LCU2000 #Helo.

	4 to 7 Days	8 to 9 Days
Config: 0 0 0 1	-0.483	0.000
Config: 0 0 0 2	0.315	0.000
Config: 0 1 0 0	0.640	0.374
Config: 0 1 0 1	0.760	0.407
Config: 0 1 0 2	0.801	0.557
Config: 0 2 0 0	0.806	0.731
Config: 0 2 0 1	0.807	0.733
Config: 0 2 0 2	0.810	0.734
Config: 1 0 0 0	0.149	0.000
Config: 1 0 0 1	0.502	0.203
Config: 1 0 0 2	0.630	0.432
Config: 1 1 0 0	0.824	0.562
Config: 1 1 0 1	0.827	0.666
Config: 1 1 0 2	0.829	0.715
Config: 2 0 0 0	0.613	0.364
Config: 2 0 0 1	0.690	0.520
Config: 2 0 0 2	0.742	0.565

Table 78. MOB2 Supply Level Utility Score for Configurations

As shown in Table 78, many of the configurations performed the same. Only some configurations were clearly dominated, but no configuration was significantly the best based on utility score alone. Based on the score, single platforms did not perform as well as multiple platforms. Also, helicopters did not add a lot to the performance of two vessels. This knowledge helped the RST calculate the efficiency of the different configurations.

7.1.5.4 Cost Performance

Cost performance graphs were compiled by plotting the cost of the configuration and the utility score. Similar to the FOB and MOB1, helicopters added very little to the overall performance but significantly increase the cost. In order to reduce the number of data points, the RST screened out configurations with helicopters. Figure 127 is a cost performance curve for the screened configurations for 4-7 days.

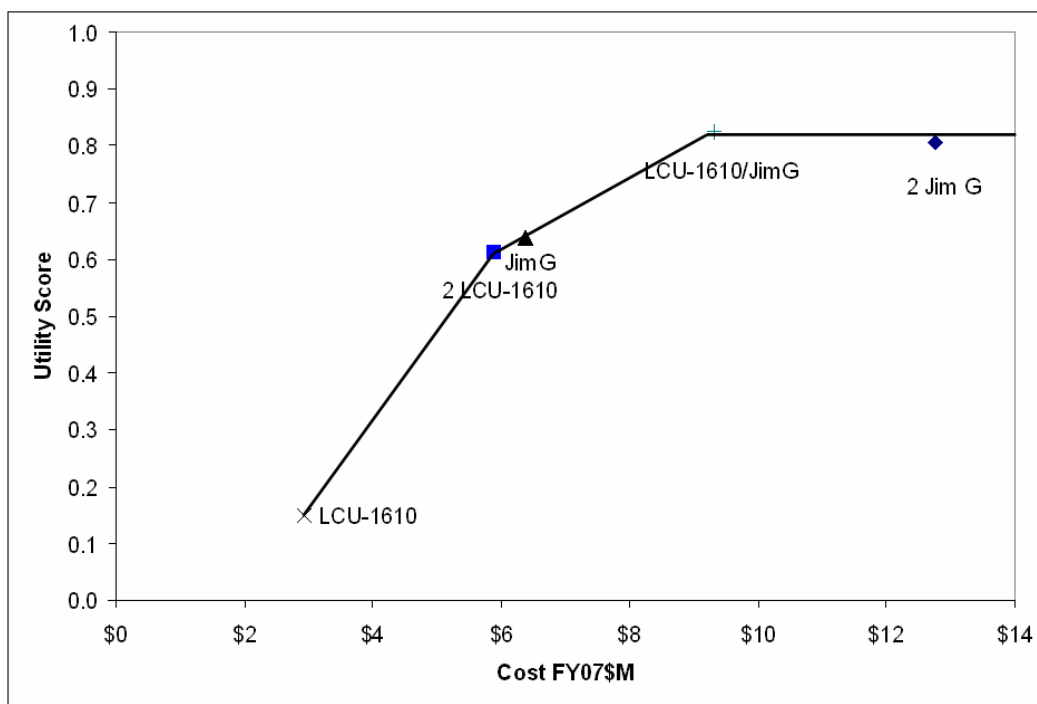

Figure 127. Connector Alternatives Cost Performance Curve for MOB2 4-7 Days

Figure 127 shows that an LCU-1610 and Jim G (Config 1100) was the most cost effective configuration. A single Jim G did not give the same performance. The same strategy was implemented for the supply ship cycle between eight and nine days. Figure 128 is a cost performance curve for the screened alternatives.

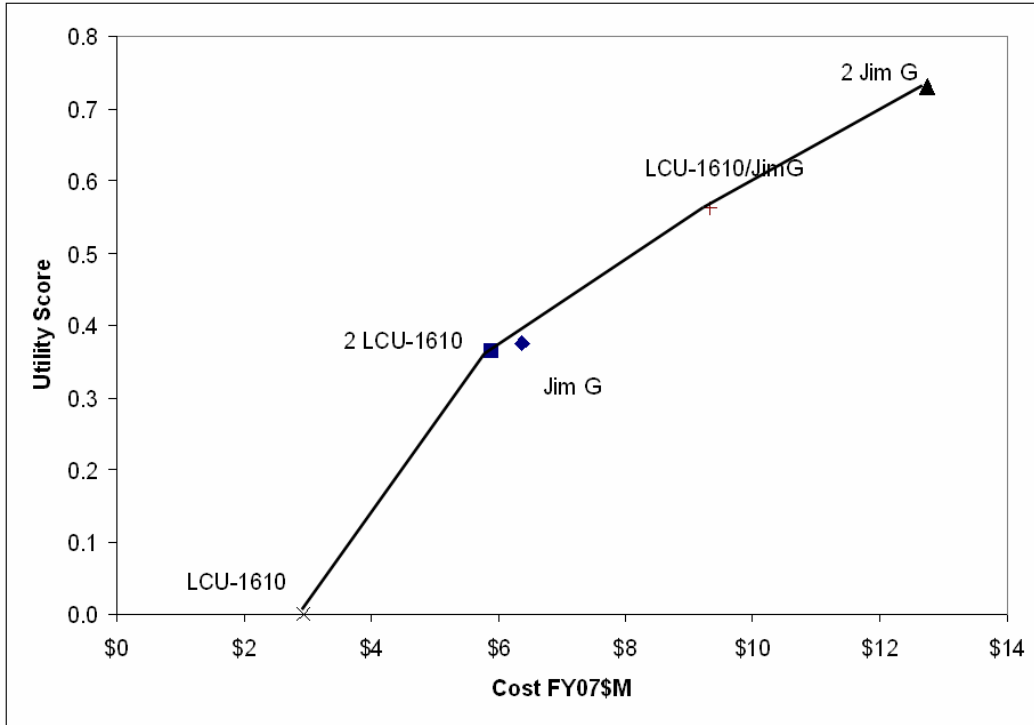

Figure 128. Connector Alternatives Cost Performance Curve for MOB2 8-9 Days

From Figure 128., the LCU-1610 and Jim G (Config 1100) decreased in performance due to the increase in supply level. This made two Jim G's configuration (Config 0200) the most cost effective.

7.1.6 Supply Software EXTEND Processes, Assumptions and Limitations

7.1.6.1 Assumptions

The capacity for food, fuel and ammunition in the supply ship is an infinite resource and will always have what is needed by the basing alternative. There are 2 types of operating bases that the supply ship can provide supplies to are the Forward Operating Base (FOB) and Mobile Operating Base at different locations (MOB2). The MOB uses organic storage tanks for fuel and water while general stores for pallets of food. The FOB uses SIXCON's for storage of fuel and water and a tent for storing pallets of food. The food, water, and fuel storage in the FOB and MOB is self-sufficient for at least 15 days.

The materiel from the supply ship will be transported to the operating bases using one of the following supply connectors: Landing Craft Utility (LCU 2000) or Off-Shore Marine Support Vessel (SEACOR Jim G). The LCU 2000 uses an organic fuel tank, SIXCON (containers) for water and deck space for delivery of pallets. SEACOR uses storage tanks for delivery of fuel and water and deck space for pallets.

Each logistics connector was modeled as having 90%, 95% or 99% survivability. The model replicates the realism that if only one logistics connector is available and has to perform three transport events to move all materiel from the supply ship, but is lost on the first run then the other two loads will also not be moved and the supply ship will leave to start its normal supply cycle over again. 90% translates to one out of every ten transport events a connector will be lost. 95% translates to one out of every 20 transport events a connector will be lost. 99% translates to one out of every 100 transport events a connector will be lost. The cycle time of the supply ship was varied from 4 - 15 days in order to see the effect on logistic connector and basing alternative performance.

7.1.7 EXTEND Analysis

7.1.7.1 Operational Availability of SURC's due to Fuel ($A_{o\ fuel\ SURC}$)

The Measure of Performance was to maximize $A_{o\ fuel\ SURC}$. Table 79 was generated for all configurations to show the differences in $A_{o\ fuel\ SURC}$.

Operational availability of SURC's due to Fuel							
	Surv.	0.9		0.95		0.99	
Days		LCU	Seacor	LCU	Seacor	LCU	Seacor
4	FOB	0.9932	0.9968	0.9977	0.9992	0.9999	0.9999
	MOB2	0.9815	0.9986	0.9991	0.9968	0.9993	0.9991
5	FOB	0.9734	0.9895	0.9905	0.9991	0.9998	0.9999
	MOB2	0.9672	0.9797	0.9847	0.9952	0.9992	0.9993
6	FOB	0.9556	0.9816	0.9832	0.9906	0.9971	0.9973
	MOB2	0.9278	0.9687	0.9731	0.9821	0.9974	0.9974
7	FOB	0.9044	0.9551	0.9645	0.9811	0.9898	0.9958
	MOB2	0.9021	0.9406	0.9567	0.9706	0.9923	0.9973
8	FOB	0.8962	0.9561	0.9451	0.9818	0.9869	0.9924
	MOB2	0.8488	0.9067	0.9232	0.9643	0.9871	0.9918
9	FOB	0.8362	0.9252	0.9258	0.9629	0.9824	0.9921
	MOB2	0.7938	0.8826	0.8781	0.9531	0.9706	0.9837
10	FOB	0.7911	0.9026	0.8843	0.9648	0.9631	0.9941
	MOB2	0.7543	0.8513	0.8631	0.8934	0.9402	0.9571
11	FOB	0.7434	0.8909	0.8441	0.9536	0.9181	0.9812
	MOB2	0.7333	0.7867	0.7972	0.8635	0.8832	0.9421
12	FOB	0.7253	0.8653	0.8049	0.9064	0.8641	0.9527
	MOB2	0.6724	0.7742	0.7652	0.8519	0.8382	0.8751
13	FOB	0.6681	0.8245	0.7515	0.8618	0.8334	0.9214
	MOB2	0.6198	0.7332	0.7193	0.7631	0.8044	0.8212
14	FOB	0.6181	0.8021	0.7226	0.8313	0.7898	0.8591
	MOB2	0.5925	0.6608	0.6681	0.7488	0.7535	0.7921
15	FOB	0.5889	0.7301	0.6627	0.7596	0.7459	0.8167
	MOB2	0.5818	0.6647	0.6485	0.6803	0.7224	0.7557

Table 79. $A_{o \text{ fuel}}$ SURC for All Configurations.

Figure 129 is a two-dimensional visualization of $A_{o \text{ fuel}}$ SURC for FOB and LCU-2000 configuration for 90%, 95%, and 99% survivability.

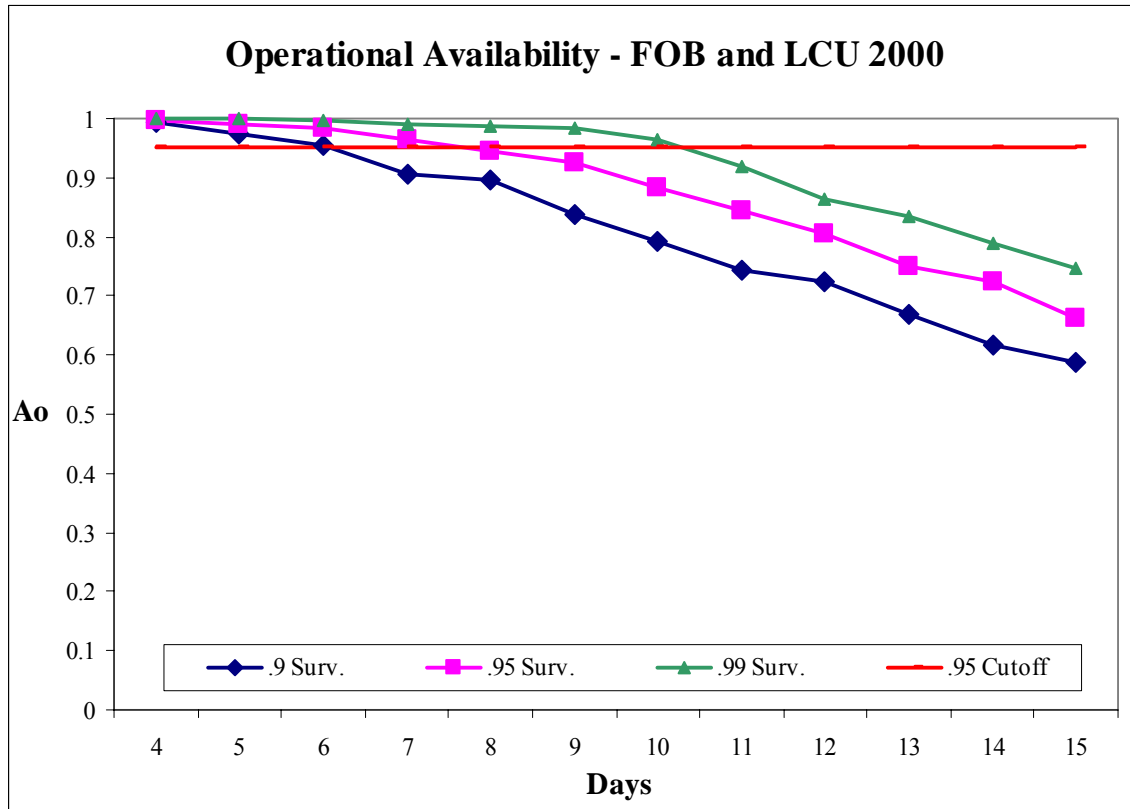

Figure 129. A_o fuel SURC for FOB and LCU-2000.

The general trend shows an increase of supply ship cycle time lowers the A_o fuel SURC. The graph also shows in order to maintain .95 A_o fuel SURC a higher survivability will increase the supply ship cycle time thus allowing for larger windows of delivery.

Figure 130 is a two-dimensional visualization of A_o fuel SURC for FOB and SEACOR “Jim G” configuration for 90%, 95%, and 99% survivability.

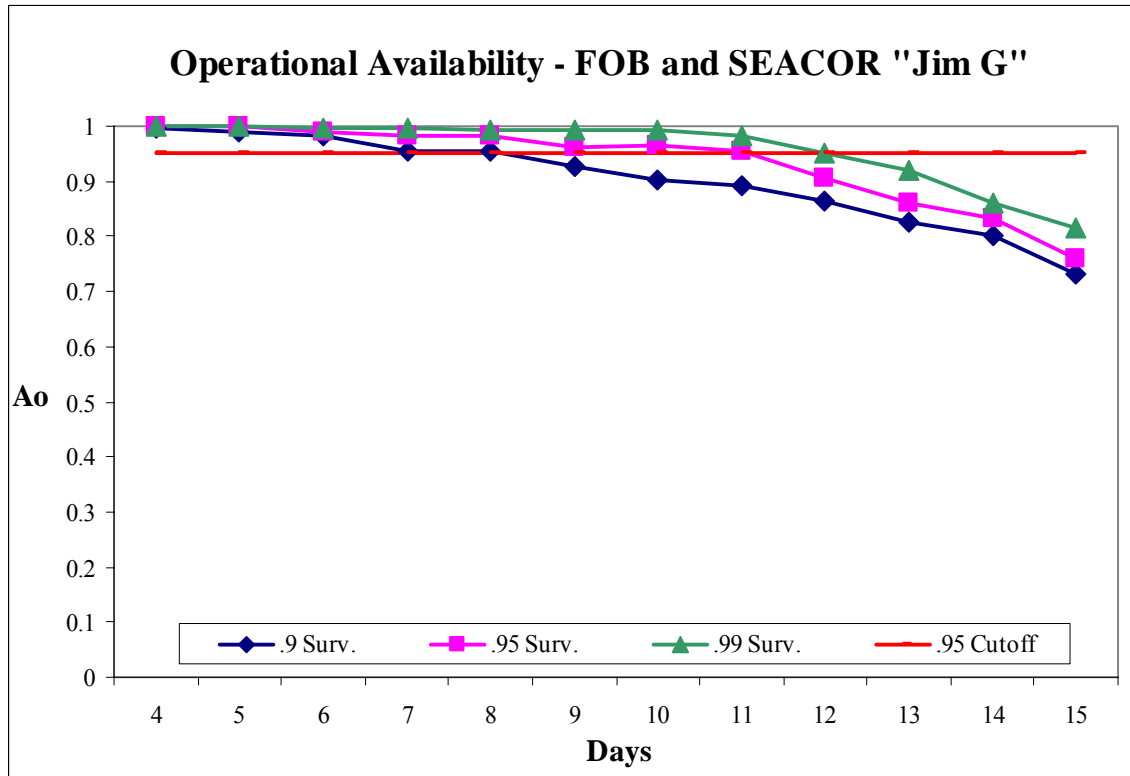

Figure 130. $A_{o \text{ fuel}}$ SURC for FOB and SEACOR “Jim G”

The general trend shows an increase of supply ship cycle time lowers the $A_{o \text{ fuel}}$ SURC. The graph also shows that to maintain .95 $A_{o \text{ fuel}}$ SURC a higher survivability will increase the supply ship cycle time thus allowing for larger windows of delivery.

Figure 131 is a two-dimensional visualization of $A_{o \text{ fuel}}$ SURC for MOB and LCU-2000 configuration for 90%, 95%, and 99% survivability.

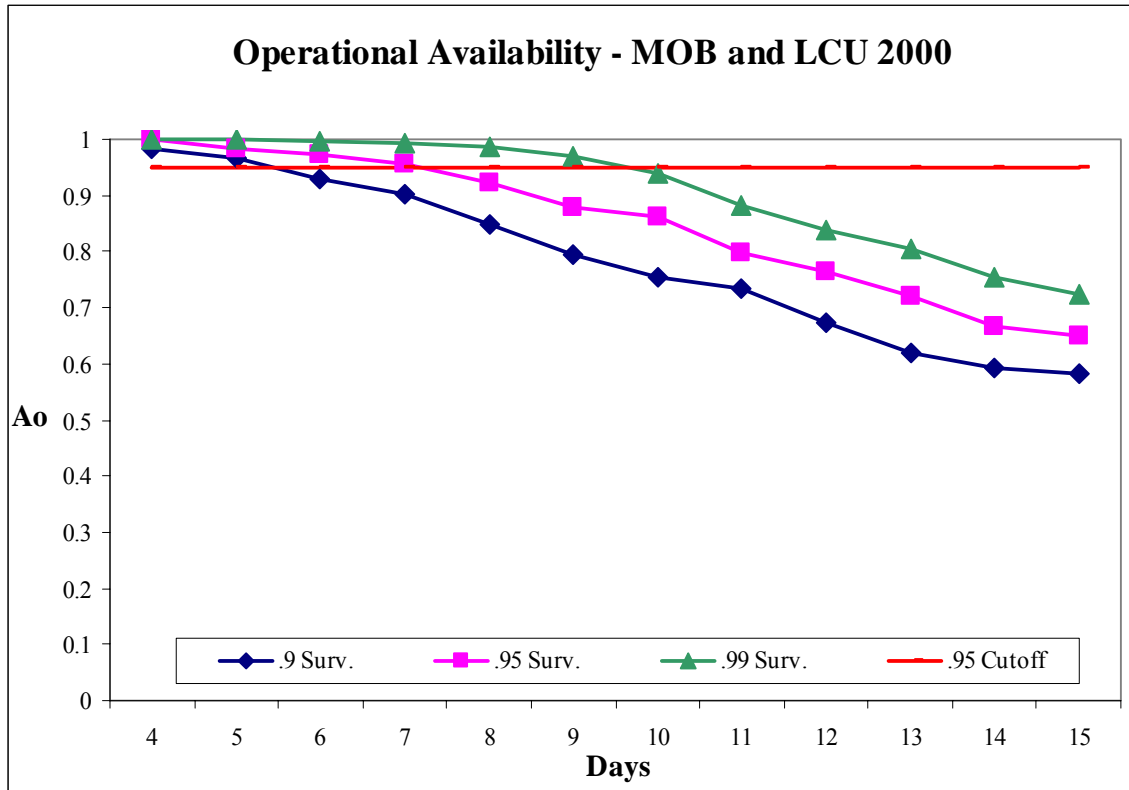

Figure 131. $A_{o \text{ fuel}}$ SURC for MOB and LCU-2000

The general trend shows an increase of supply ship cycle time lowers the $A_{o \text{ fuel}}$ SURC. The graph also shows that to maintain .95 $A_{o \text{ fuel}}$ SURC a higher survivability will increase the supply ship cycle time thus allowing for larger windows of delivery.

Figure 132 is a two-dimensional visualization of $A_{o \text{ fuel}}$ SURC for MOB and SEACOR “Jim G” configuration for 90%, 95%, and 99% survivability.

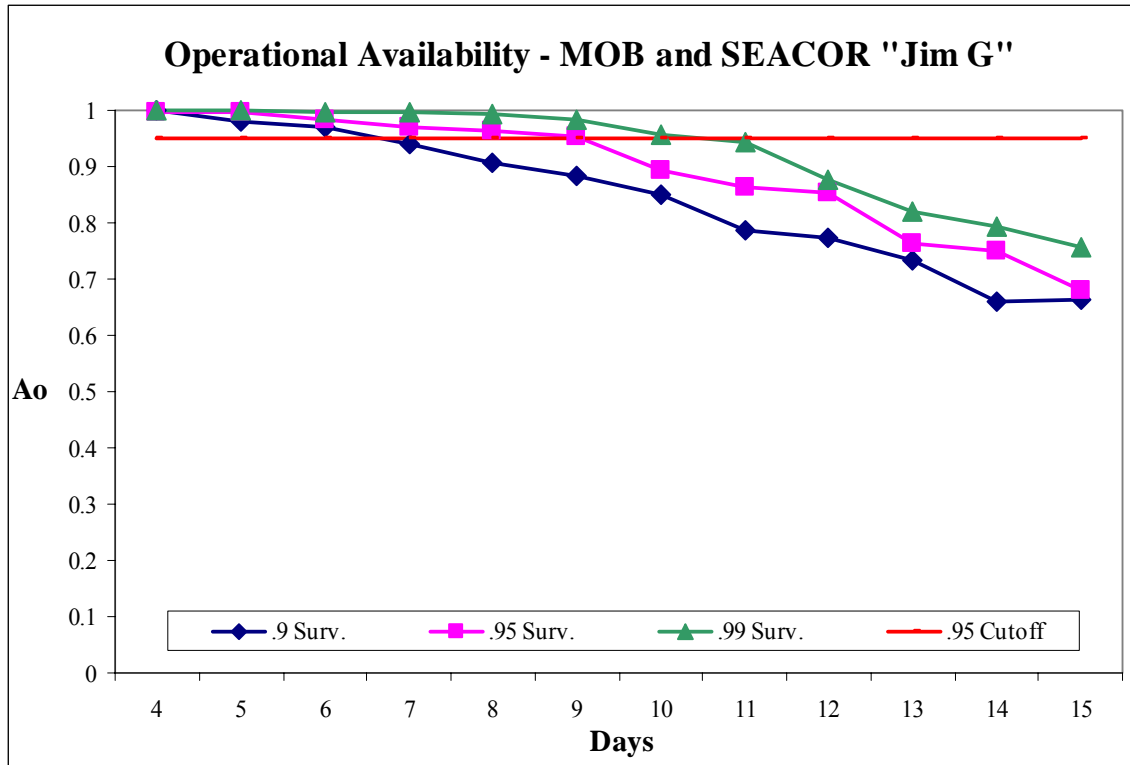

Figure 132. A_o fuel SURC for MOB and SEACOR "Jim G"

The general trend shows an increase of supply ship cycle time lowers the A_o fuel SURC. The graph also shows that to maintain .95 A_o fuel SURC a higher survivability will increase the supply ship cycle time thus allowing for larger windows of delivery.

7.1.7.2 Operational Habitability of Base due to food and water (A_o food & Water Base)

The Measure of Performance was to maximize A_o food & Water Base. Table 80 was generated for all configurations to show the differences in A_o food & Water Base.

Operational Habitability of base due to food and water							
	Surv.	0.9		0.95		0.99	
Days		LCU	Seacor	LCU	Seacor	LCU	Seacor
4	FOB	0.9934	0.9962	0.9975	0.9993	0.9999	0.9999
	MOB2	0.9596	0.9944	0.9956	0.9936	0.9979	0.9981
5	FOB	0.9711	0.9881	0.9896	0.9987	0.9999	0.9999
	MOB2	0.9305	0.9489	0.9623	0.9851	0.9968	0.9962
6	FOB	0.9431	0.9747	0.9799	0.9861	0.9974	0.9964
	MOB2	0.8463	0.9373	0.9439	0.9639	0.9899	0.9919
7	FOB	0.8847	0.9331	0.9605	0.9819	0.9909	0.9962
	MOB2	0.8104	0.8815	0.9092	0.9425	0.9791	0.9882
8	FOB	0.8636	0.9422	0.9343	0.9774	0.9825	0.9911
	MOB2	0.7153	0.8347	0.8425	0.9143	0.9528	0.9737
9	FOB	0.7758	0.8813	0.9115	0.9418	0.9809	0.9893
	MOB2	0.6251	0.7803	0.7537	0.8945	0.8977	0.9382
10	FOB	0.7155	0.8541	0.8489	0.9479	0.9669	0.9941
	MOB2	0.5611	0.7278	0.7214	0.7864	0.8282	0.8796
11	FOB	0.6533	0.8371	0.8147	0.9357	0.9186	0.9815
	MOB2	0.5387	0.6361	0.6126	0.7298	0.7285	0.8456
12	FOB	0.6469	0.8174	0.7616	0.8891	0.8521	0.9499
	MOB2	0.4641	0.6163	0.5631	0.7064	0.6581	0.7381
13	FOB	0.5574	0.7731	0.6963	0.8253	0.8279	0.9307
	MOB2	0.3981	0.5607	0.5168	0.6045	0.6263	0.6676
14	FOB	0.4961	0.7347	0.6507	0.8111	0.7694	0.8606
	MOB2	0.3602	0.4722	0.4615	0.5788	0.5611	0.6344
15	FOB	0.4547	0.6381	0.5671	0.6981	0.6885	0.7972
	MOB2	0.357	0.4659	0.4363	0.5024	0.5252	0.5842

Table 80. $A_{o \text{ food \& Water Base}}$ for all configurations.

Figure 133 is a two-dimensional visualization of $A_{o \text{ food \& Water Base}}$ for FOB and LCU-2000 configuration for 90%, 95%, and 99% survivability.

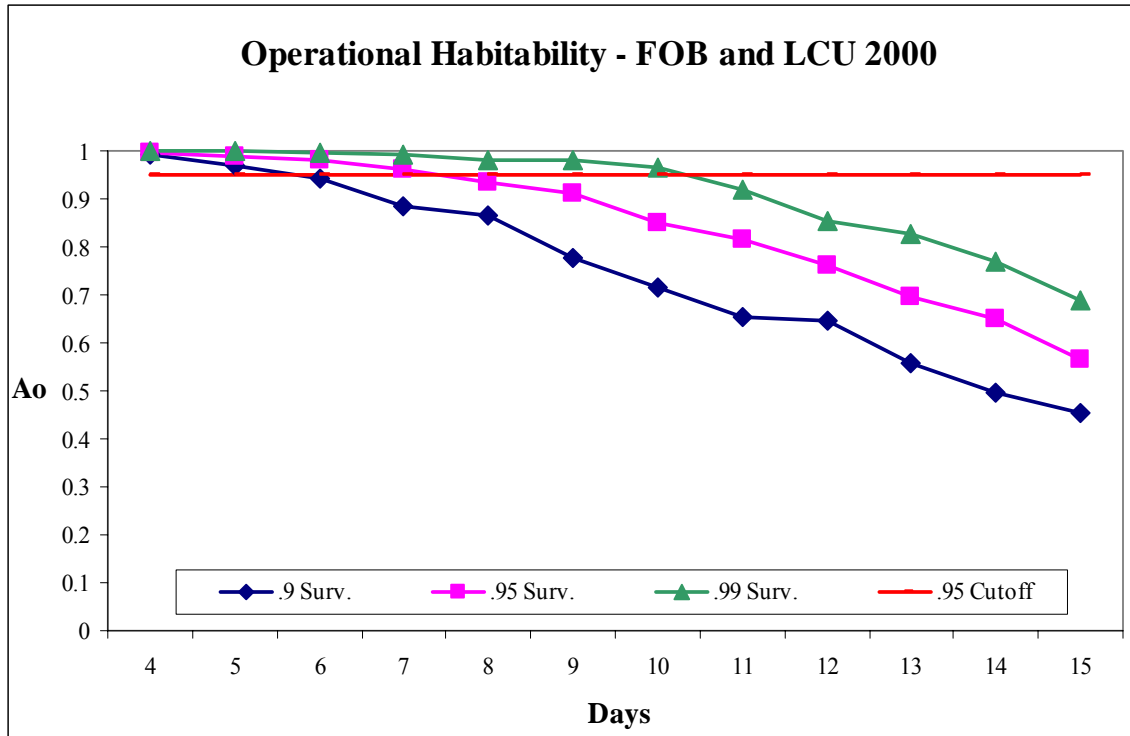

Figure 133. A_o food & Water Base for FOB and LCU-2000.

The general trend shows an increase of supply ship cycle time lowers the A_o food & Water Base. The graph also shows that to maintain .95 A_o food & Water Base a higher survivability will increase the supply ship cycle time thus allowing for larger windows of delivery.

Figure 134 is a two-dimensional visualization of A_o food & Water Base for FOB and SEACOR “Jim G” configuration for 90%, 95%, and 99% survivability.

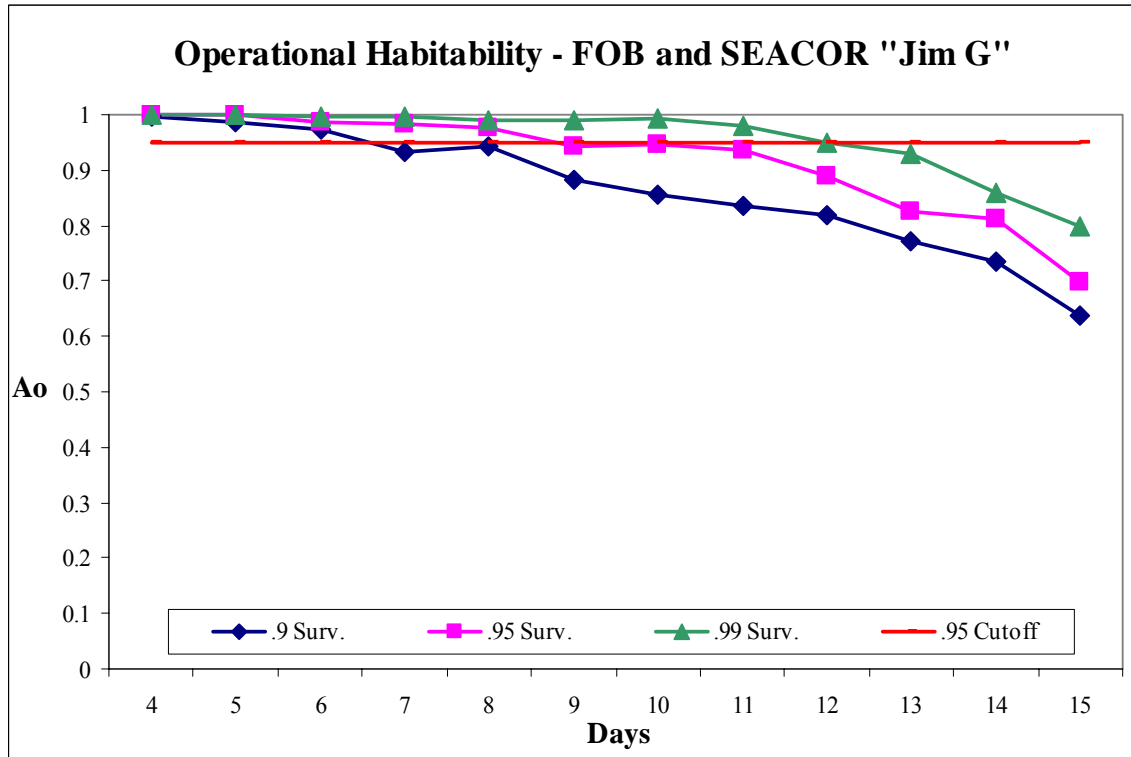

Figure 134. A_o food & Water Base for FOB and SEACOR "Jim G"

The general trend shows an increase of supply ship cycle time lowers the A_o food & Water Base. The graph also shows that to maintain .95 A_o food & Water Base a higher survivability will increase the supply ship cycle time thus allowing for larger windows of delivery.

Figure 135 is a two-dimensional visualization of A_o food & Water Base for MOB and LCU-2000 configuration for 90%, 95%, and 99% survivability.

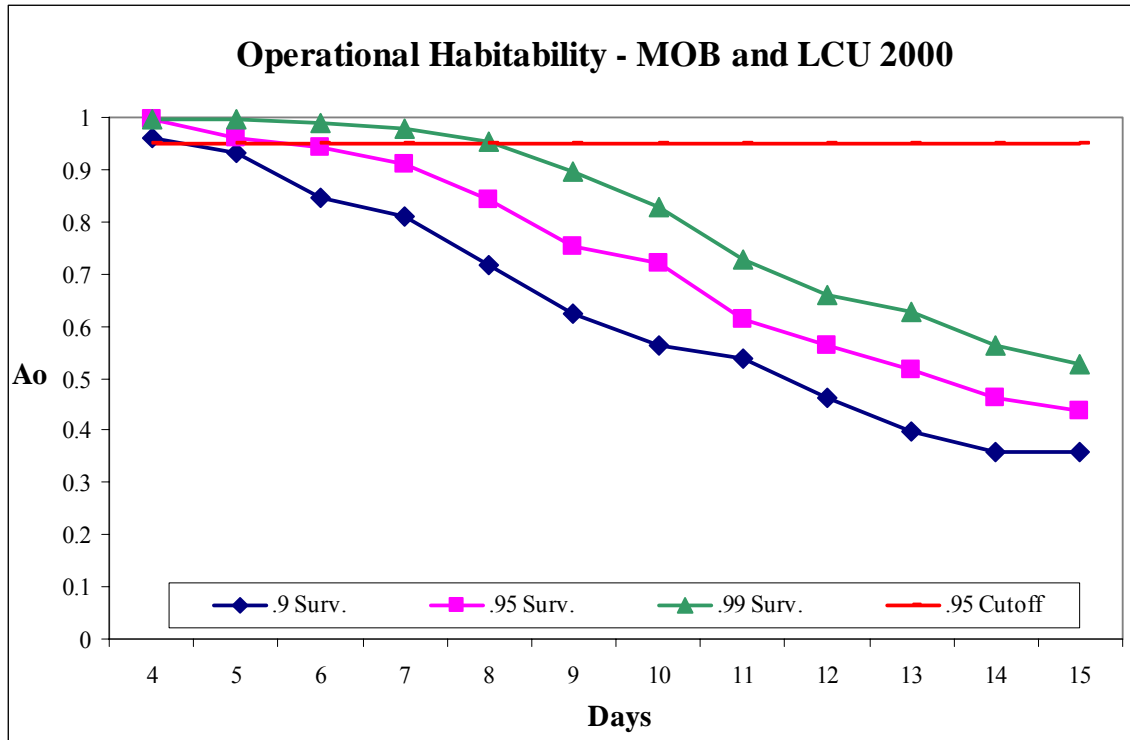

Figure 135. A_o food & Water Base for MOB and LCU-2000

The general trend shows an increase of supply ship cycle time lowers the A_o food & Water Base. The graph also shows that to maintain .95 A_o food & Water Base a higher survivability will increase the supply ship cycle time thus allowing for larger windows of delivery.

Figure 136 is a two-dimensional visualization of A_o food & Water Base for MOB and SEACOR “Jim G” configuration for 90%, 95%, and 99% survivability.

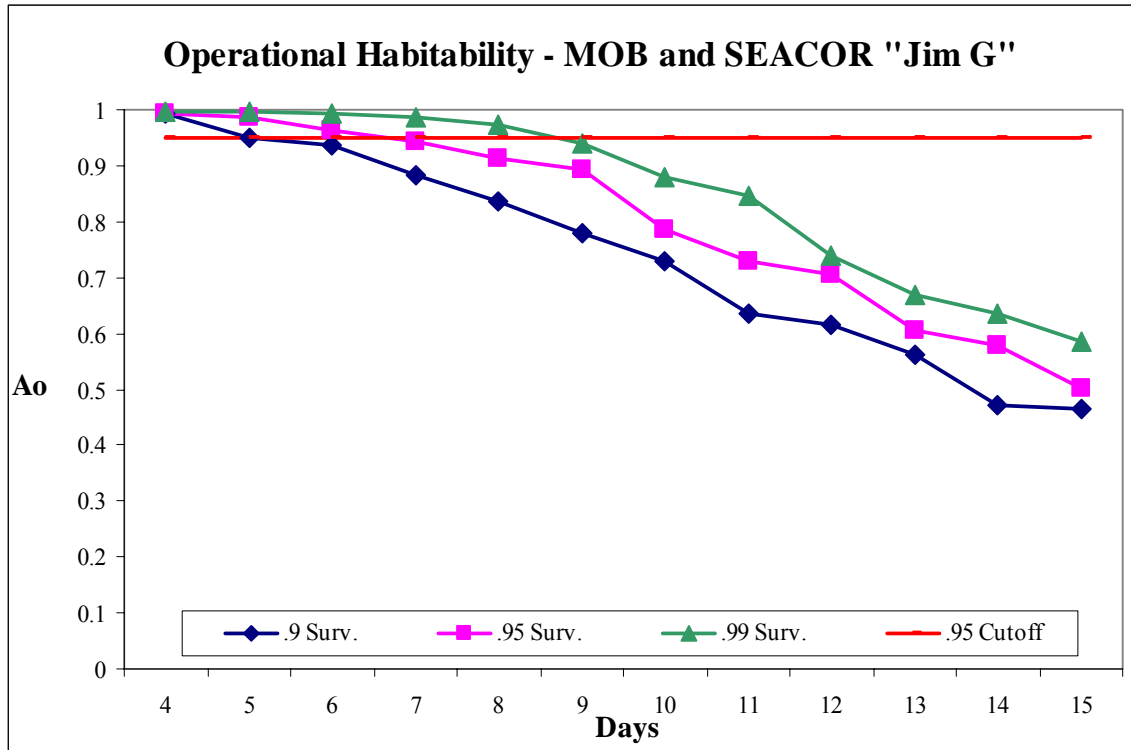

Figure 136. A_o food & Water Base for MOB and SEACOR “Jim G”

The general trend shows an increase of supply ship cycle time lowers the A_o food & Water Base. The graph also shows that to maintain .95 A_o food & Water Base a higher survivability will increase the supply ship cycle time thus allowing for larger windows of delivery.

7.1.7.3 Average number of lost logistic connectors during operation.

The Measure of Performance was to minimize number of lost logistic connectors. Table 81 was generated for all configurations to show the differences in the number of lost logistic connectors.

Number of Lost Connectors							
	Surv.	0.9		0.95		0.99	
Days		LCU	Seacor	LCU	Seacor	LCU	Seacor
4	FOB	7	4	4	2	1	1
	MOB2	7	4	3	3	1	1
5	FOB	6	4	4	2	1	1
	MOB2	7	6	4	4	1	1
6	FOB	6	5	3	2	1	1
	MOB2	8	5	4	3	1	1
7	FOB	6	5	3	3	1	1
	MOB2	5	5	4	3	1	1
8	FOB	5	4	4	3	1	1
	MOB2	6	5	2	2	1	1
9	FOB	5	4	3	2	1	1
	MOB2	6	4	2	3	1	1
10	FOB	5	4	3	2	1	1
	MOB2	6	5	4	2	1	1
11	FOB	4	3	3	1	1	1
	MOB2	6	5	3	2	1	1
12	FOB	5	3	3	1	1	1
	MOB2	6	4	3	2	1	1
13	FOB	4	2	2	2	1	1
	MOB2	6	4	4	2	1	1
14	FOB	4	3	3	2	1	1
	MOB2	5	4	2	3	1	1
15	FOB	4	3	3	2	1	1
	MOB2	4	5	3	2	1	1

Table 81. Number of Lost Connectors for each configuration.

The following figures show the number of lost connectors for each supply ship cycle time at each of the different configurations. The general trend of all figures is that the lower the survivability the more lost connectors. This is also a function of the number of transport events that must be done in order to move all the materiel required. As the supply ship cycle time extends the more materiel that must be moved but the number of s times the supply ship shows up is less during the 180 days. This causes the

unique jumps and dips in all the curves of the figures except the 99% survivability curve where the expected number of lost connectors is always one.

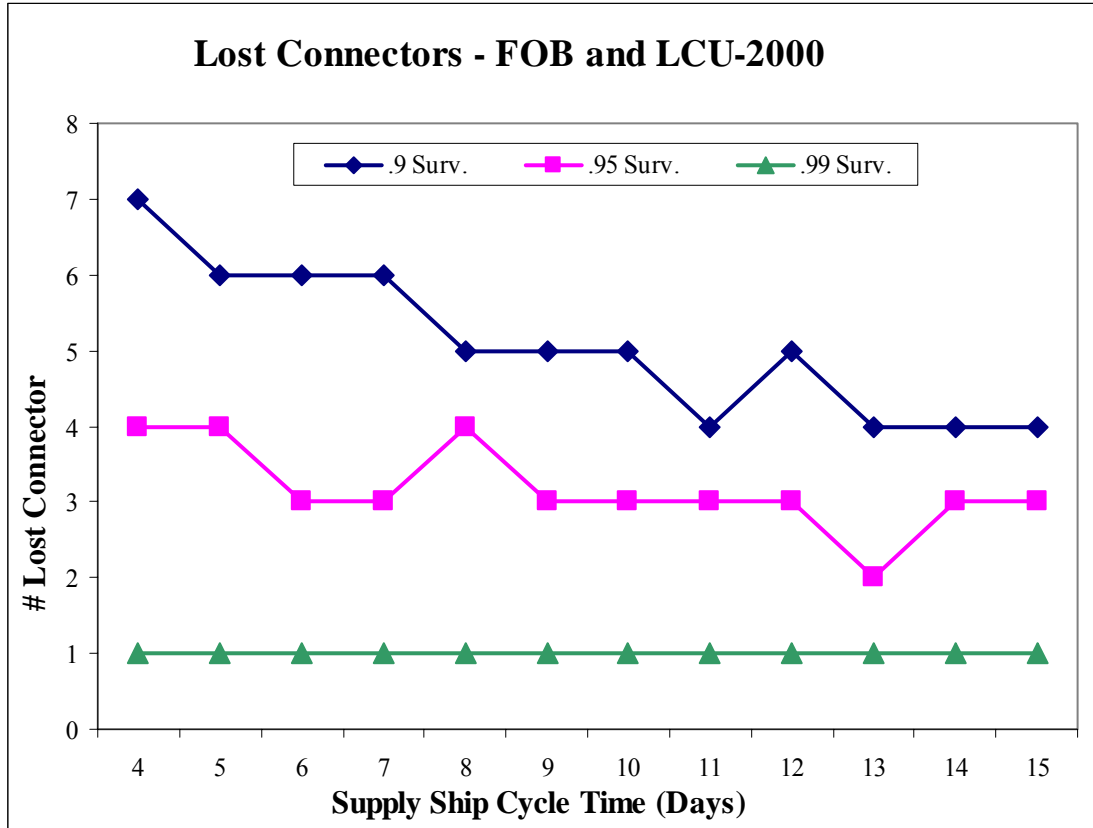

Figure 137. Lost Connectors using FOB and LCU-2000 configuration as a function of supply ship cycle time.

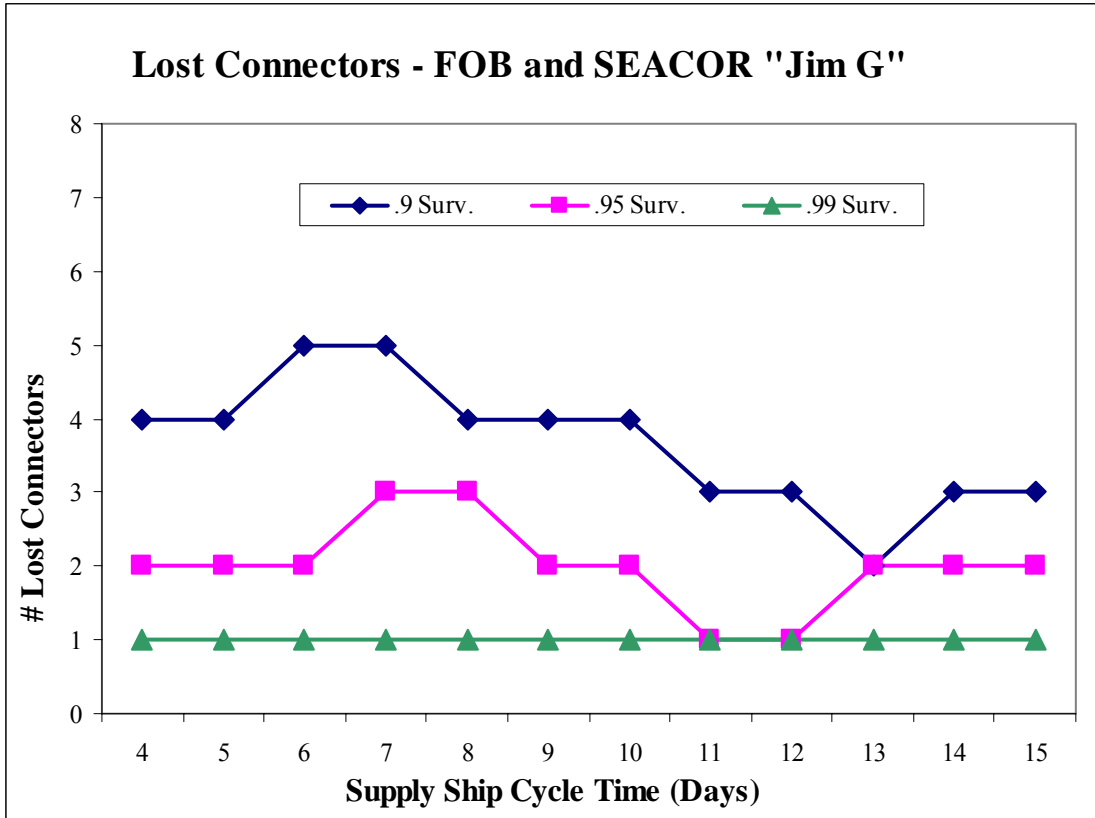

Figure 138. Lost connectors using the FOB and SEACOR “Jim G” configuration as a function of supply ship cycle time.

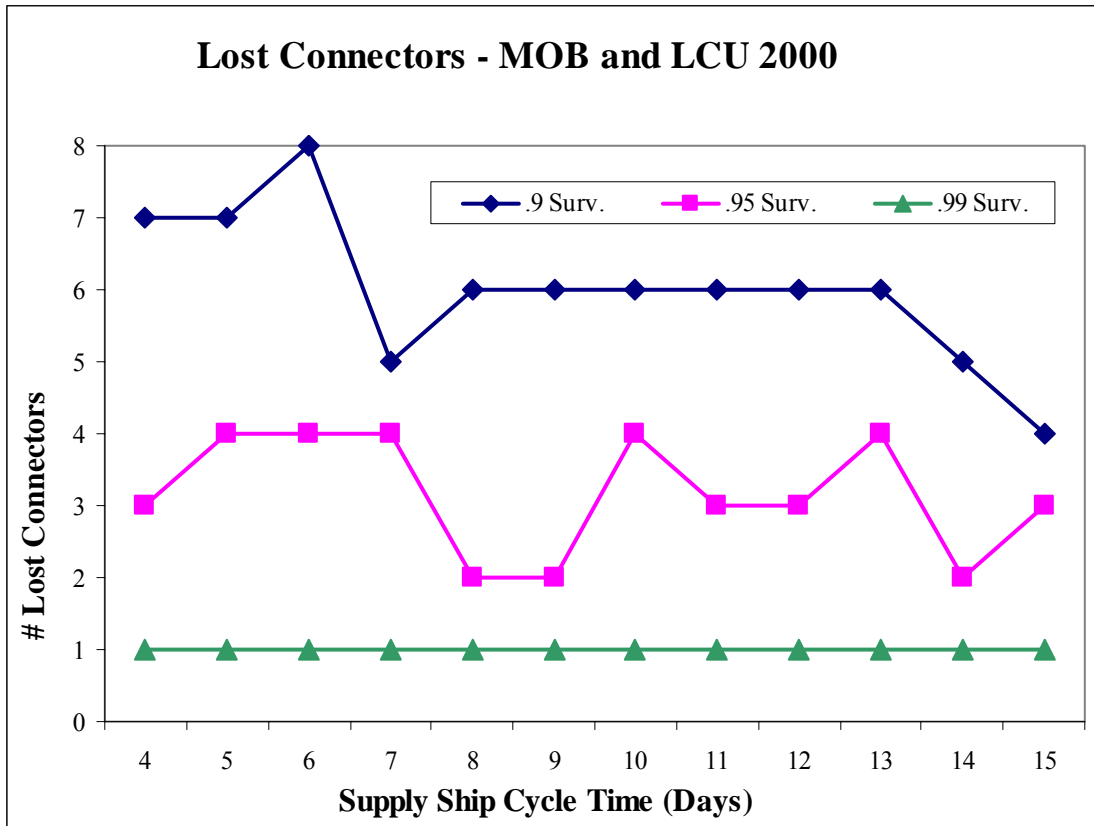

Figure 139. Lost connectors using the MOB and LCU-2000 configuration as a function of supply ship cycle time.

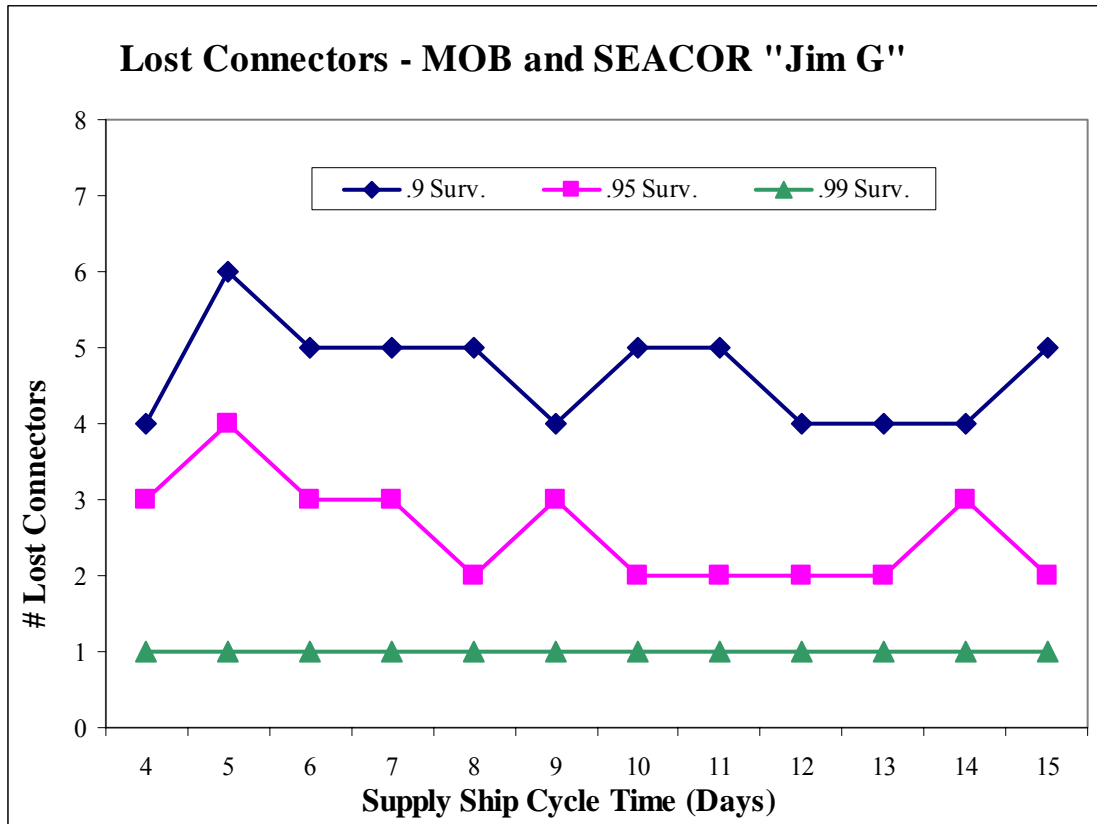

Figure 140. Lost connectors using the MOB and SEACOR “Jim G” configuration as a function of supply ship cycle time.

7.1.8 EXTEND Cost Performance

Cost performance graphs were created by comparing the Lost Cost of the operation with the supply ship cycle time for each basing alternative. The Lost Cost refers to the amount of cost that will be accrued by losing the average number of logistic connectors during the 180 day operation. The Lost Cost is determined by adding the procurement cost for a new logistics connector, the cost of the crew, and the cost of the cargo. For each Lost Cost of an operation there is a window of delivery in which the supply ships can be scheduled in order to maintain 95% $A_{o \text{ fuel SURC}}$. Figure 141 is the Lost Cost for each configuration of the FOB.

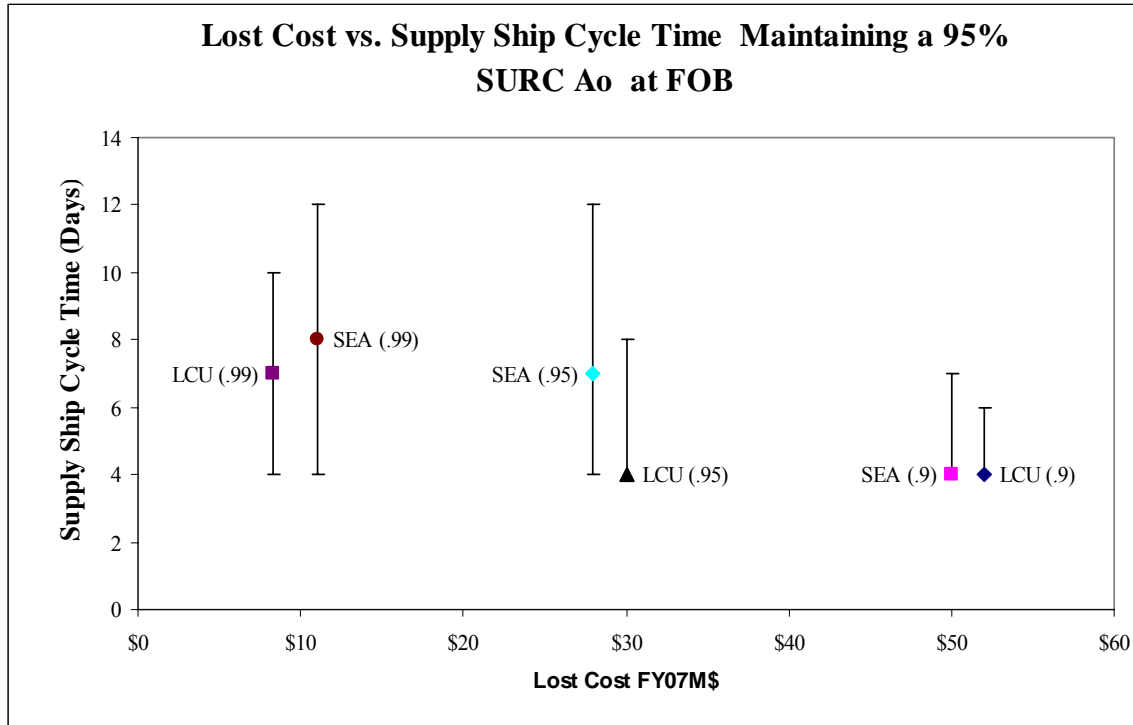

Figure 141. Lost Cost for each configuration of the FOB.

Figure 141 shows a general trend that as the survivability lowers so does the delivery window options for supply ship cycle time. Figure 141 shows the trade space between the variables supply ship cycle time, logistics connector survivability, operational availability, and lost cost. By using the full spectrum of the trade space Figure 141 can be used as a predictor for the supply ship cycle time. If using a FOB and the threat is high meaning a large chance of losing a logistics connector (survivability 90%) then the supply ship cycle time should be 4-7 days using a SEACOR “Jim G” for a lost cost of \$50M or 4-6 days using a LCU-2000 for a lost cost of 53 M\$.

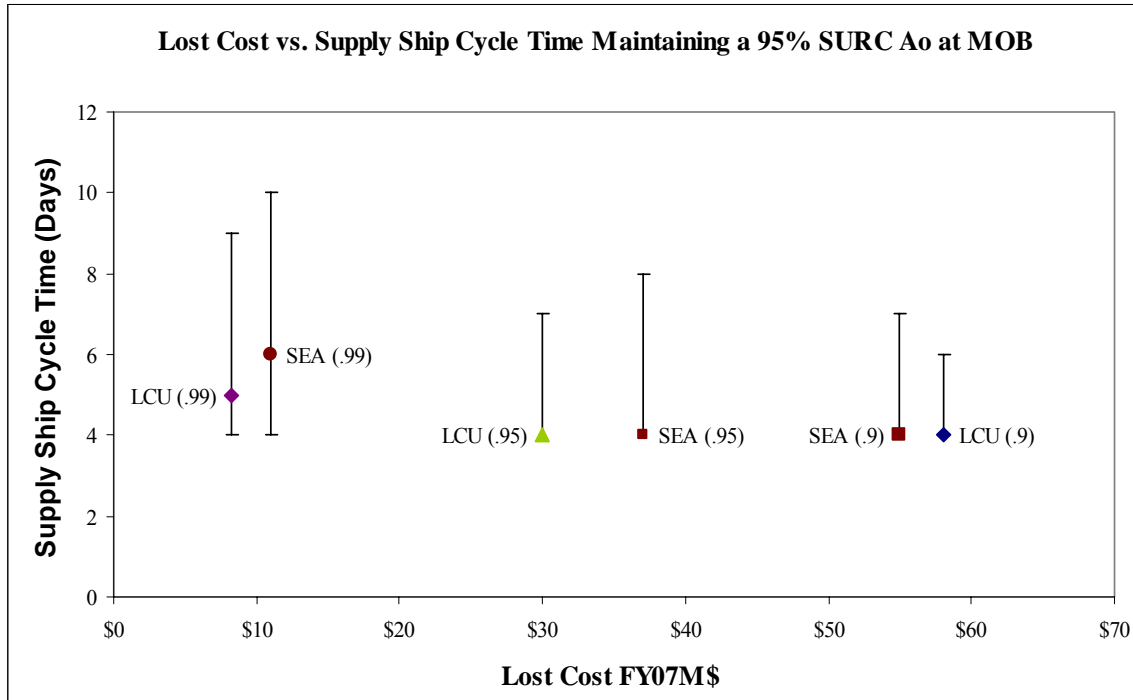

Figure 142. Lost Cost for each configuration of the FOB.

Figure 142 shows a general trend that as the survivability lowers so does the delivery window options for supply ship cycle time. Figure 142 shows the trade space between the variables supply ship cycle time, logistics connector survivability, operational availability, and lost cost. By using the full spectrum of the trade space Figure 142 can be used as a predictor for the supply ship cycle time. If using a MOB and the threat is high meaning a large chance of losing a logistics connector (survivability 90%) then the supply ship cycle time should be 4-7 days using a SEACOR “Jim G” for a lost cost of \$55M or 4-6 days using a LCU-2000 for a lost cost of \$58M.

7.2 REPAIR GROUP

When the status quo is compared to the alternatives, it is clear that Measures of Performance of the RF maintenance alternatives are statistically identical. For this reason, typical data normalization does not apply. Table 82 shows the Status Quo’s MOP’s compared to the alternatives. In terms of efficiency, a minor increase in A_0 comes at a significant expense.

	MCMT	MPMT	A _o of a SURC with Parts On-Hand	Average Number of SURCs Available
SQ	6.42	7.14	88.84%	8
INC PERS	5.76	6.17	90.05%	8
INC ALL 3	5.72	6.02	90.20%	9
INC BAYS	6.58	7.02	88.82%	8
INC SURCs	6.42	6.82	89.08%	9
INC BAY/SURC	6.61	7.01	88.80%	9
INC PERS/BAY	5.55	6.10	90.27%	9
INC PERS/SURC	5.62	5.79	90.44%	9

Table 82. Repair Raw Data Matrix

With regard to the model’s demonstration of sensitivity between alternatives, it is clear that there is strong sensitivity across all alternatives to MSRT and MTBF, due to the nature of the equation and the value of the mean CM and PM times when compared to the larger MTBF and MSRT figures. Recall the following equation from Chapter 5:

$$A_o = \frac{MTBF}{MTBF + MCRT + MPRT + MSRT}$$

RST Operational Availability⁴²⁹

From this equation, one can deduce that a MSRT of anything beyond 24 hours (Figure 143), when matched with a MTBF of 108 operating hours, reduces SURC availability below acceptable operational availability levels. This conclusion is yielded despite rapid maintenance response times indicated by MCMT and MPMT.

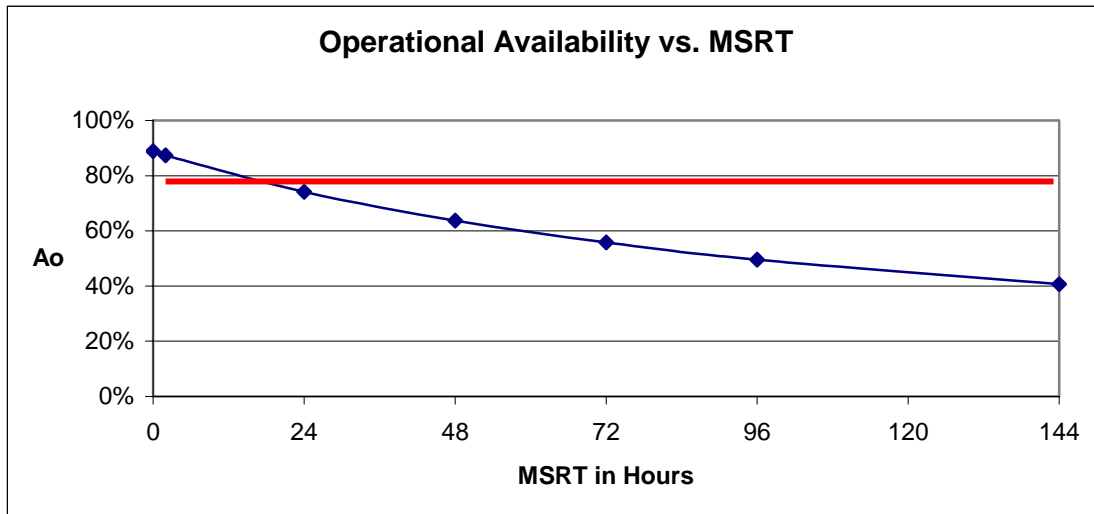

Figure 143. SURC Operational Ao versus MSRT

For the purposes of this study, the RST used an operational availability threshold of 80%, which was derived from a similar platform’s operational requirements document.⁴³⁰ Other factors such as administrative delays, and increased work delays due to resource unavailability had a similar influence on all alternatives. None of the alternatives showed any significant resistance to such changes.

7.3 FORCE PROTECTION GROUP

7.3.1 Revised Measures of Performance

The MOP’s that were derived for in the objectives hierarchy for a FPS were modified by the RST as modeling was conducted. Table 83 below is a summary of the changes made.

Measure of Effectiveness	Measures of Performance	Revised Measures of Performance	Reason for change
Percentage of Unsuccessful Attacks	Range of detection.	Time of enemy casualty.	Modeling limitation/
Force Exchange Ratio	Probability of detection.	Number of enemy hits on a single entity	Modeling limitation.
	Time to locate shot after detection.	Force Exchange Ratio	No change
	Time spent on object after locating.	Number of enemy penetrations	Preference
	Range a contact can be identified.	Mean distance of enemy casualties	Preference
	Time to identify after contact detected.	Number of RF casualties	Preference
	Weapon range.	Number of SURCs destroyed	Preference
	Probability of kill of enemy with weapon.		
	Probability of hit of enemy with weapon.		
	Damage to RF personnel and structures		
	Number of friendly forces and critical structures detected.		
	Maneuverability of critical infrastructures.		

Table 83. Force Protection MOP Revisions

The RST derived revised measures of performance because of limitations in modeling and preference. The revised MOP's were selected because they all captured the intent of the original MOP's, or provided an added evaluation measure that was not previously considered.

7.3.1.1 Time of enemy casualty

This MOP was used as a substitute for time to detect due to modeling limitations and preference in the mortar attack scenario. The RST enabled the single

entity that registered hits continuous coverage of the entire area throughout the simulation to aide in modeling. This entity was then weaponized to serve as the mortar/LCMR combination for the specific architectures. This prevented the time of detection from serving as an accurate measure because the enemy was detected immediately as they were setting up the mortar, rather than when a mortar lands on the FOB, or when the UAV detected the enemy firing the mortar. Every architecture, however, that had the ability to detect the enemy, also had the capability to fire on the enemy immediately after this detection, so the time of an enemy’s casualty more accurately reflected the intent of the time of detection MOP.

7.3.1.2 Number of Enemy Hits on a Single Entity

This MOP was used in the mortar attack scenario in MANA to demonstrate the potential damage inflicted by the enemy mortars. The scale of the map in this scenario did not permit a detailed view of casualties and damage to specific facilities, so the number of hits taken on a single entity was used to serve as an approximation.

7.3.1.3 The Force Exchange Ratio

The equation for the Force Exchange Ratio used by the RST was:

$$ForceExchangeRatio = \frac{\left(\frac{Blue_{casualties}}{Blue_{Total}}\right)}{\left(\frac{Red_{casualties}}{Red_{Total}}\right)}$$

This did not represent a change from the intended MOE, but the equation used by the RST was the inverse of the equation that is commonly used, because there were results from the modeling that contained runs with zero blue casualties. This MOP/MOE was only used in the raid on the FOB scenario.

7.3.1.4 Number of Enemy Penetrations

The RST reasoned that the number of enemy penetrations an excellent indication of the success of a FPS architecture in denying the commando raid threat. The requirement for an enemy infiltration in the raid was if the enemy crossed a point that was 270 grids, or 472.5 yards (1.75 yards/grid for the raid scenario) from the center of the FOB.

7.3.1.5 Mean Distance of Enemy Casualties

This MOP was used in the boat attack scenarios to estimate how far the attacking boats could penetrate. The attacking boats automatically detonated when they reached the moored SURC's, so the average location of the casualties of these boats provided insight into the capability of the FPS.

7.3.1.6 Number of RF casualties

This MOP was used in the boat attack scenarios. The MOP was used as an aspect of the damage to the RF personnel and structures. For the boat attack scenarios, there were specific numbers of hit required to kill blue personnel and other entities. The personnel on in the gun posts for the FOB were given two hits to kill while the personnel operating the weapon stations on the MOB were given three hits to kill. The casualties of the personnel on the PBL's could not be reflected so the RST assumed that 15 hits to a PBL would account for the death of the crew and disable the craft.

7.3.1.7 Number of SURC's Destroyed

This MOP was selected for the boat attack scenarios because the SURC's represented the enemy's primary target, as the destruction of the SURC's would result in freedom to move arms on the river.

7.3.2 Statistical Comparison of MOP's and Raw Data Matrices

The raw data from the MANA simulations was outputted into excel format. The RST used MATLAB to draw the data from excel and generate the specific MOP's desired for each scenario. MATLAB was also used to analyze the MOP's for comparing architectures to determine statistical significance.

The results of the simulation runs, such as the time of first detection or the number of forces killed, were expected to distribute in a similar manner for different scenarios, but the RST could not differentiate the type of distribution, specifically, whether the distribution could be approximated as normal. Furthermore, there was an indication that the distributions were not normal, because the MOP's assumed positive values, and hence the required left "tail" of the Gaussian did not exist. In cases like these, rather than use a standard analysis of variance (ANOVA) to test the significance of our conclusions about the differences or similarities between the treatments compared, a different set of tests, called non-parametric tests, were used. An appropriate non-parametric test for our case was the Kruskal-Wallis. The Kruskal-Wallis tests the hypothesis that the mean values of the parameters analyzed are equal for the different treatments, with the sole requirement that the variability around the means is taken from the same distribution (not necessarily normal). In the analysis conducted on the MOP's of the FPS architectures, the null hypothesis (H_0) was that the MOP's would have equal expected values. If at least one of them were different (H_a), the analysis revealed the difference with a certain level of significance that was calculated in each test.

The first step of the Kruskal-Wallis test was to rank the entire set of observations (for all treatments) according to their value, from lowest to highest. Let R_{ij} be the rank of the j^{th} observation of treatment i (out of total I treatments), N the total number of observations and J_i the number of observations of treatment i . Then the test statistic K can be expressed as:

$$K = \frac{12}{N(N+1)} \sum_{i=1}^I \left(\overline{R_{i\cdot}} - \frac{N+1}{2} \right)^2 = \frac{12}{N(N+1)} \sum_{i=1}^I \frac{\overline{R_{i\cdot}}}{J_i} - 3(N+1)$$

The above test statistic was a measure of the extents to which the average ranks of the different observations deviated from their expected value $(N+1)/2$ in the case of equal averages.⁴³¹ For a large number of observations (as in our case – 20 observations of each case in each scenario), K will have approximately the chi-squared distribution for $I-1$ degrees of freedom. For a certain level of significant α , if $K > \chi^2_{\alpha, I-1}$ the null hypothesis was rejected (which means that K holds an improbable value if we assume that H_0 is true).

7.3.2.1 Mortar MOP Results and Statistical Analysis

Figure 144 and Figure 145 are the box plots for the MOP's of the mortar attack scenario: time of first detection/enemy casualty and number of hits on the FOB. All values that denote time were taken in MANA time steps. For all of the tests below, H_0 is the null hypothesis, that all of the cases tested have the same means μ_i . H_a is the alternative – that at least one of the μ_i 's is different. H_a is accepted when the difference between the means is statistically significant.

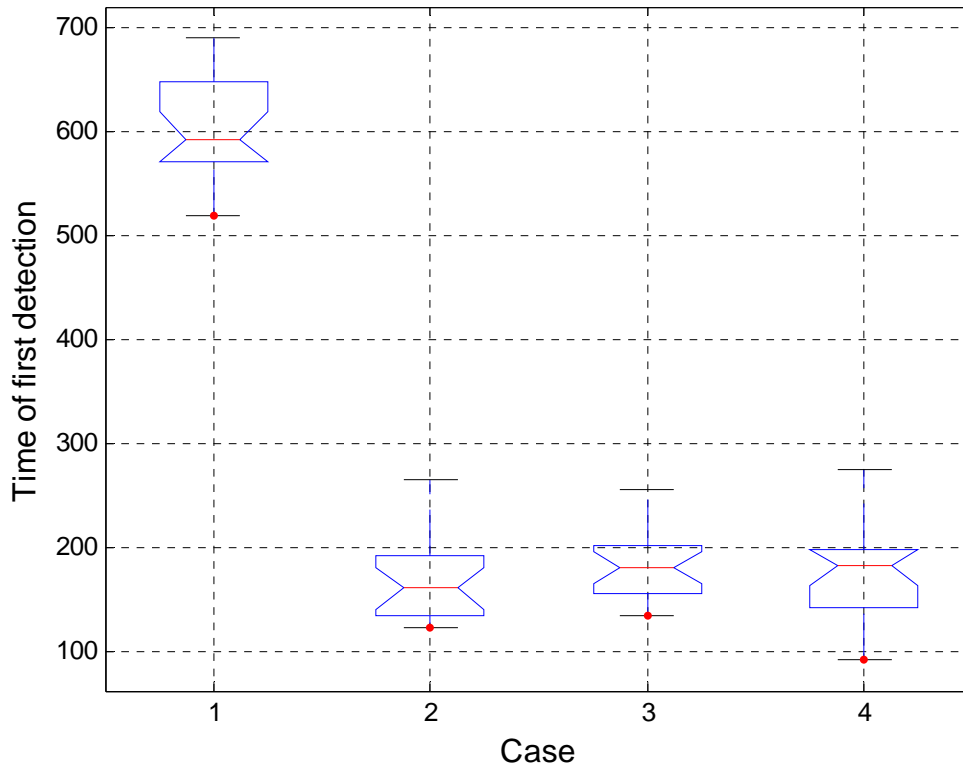

Figure 144. Time of First Enemy Detection/Enemy Casualty

The order of the case numbers corresponded to the following architectures; 1, baseline defense; 2, mortar and UAV; 3, mortar and LCMR; and 4, mortar, LCMR, and UAV. The Kruskal-Wallis analysis was conducted as indicated:

$$H_0: \mu_1 = \mu_2 = \mu_3 = \mu_4$$

Significance level (That at least one is different): > 99.99%

Case 1 is significantly worse than the others.

$$H_0: \mu_2 = \mu_3 = \mu_4$$

They are not significantly different – significance level only 56.11%.

Ranking (worst – best): 1 – 2, 3, 4

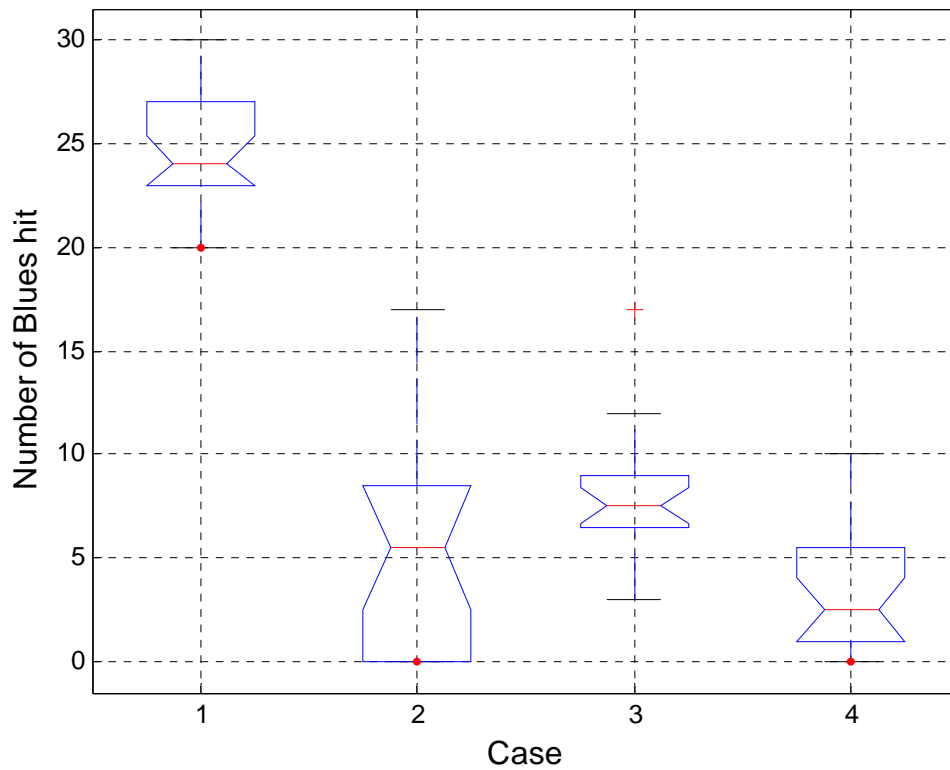

Figure 145. Number of Hits on FOB

The order of the cases is the same as in the box plot of the time of first detection/enemy casualty plot.

$$H_0: \mu_1 = \mu_2 = \mu_3 = \mu_4$$

Significance level (That at least one is different): > 99.99%

Case 1 is significantly worse than the others.

$$H_0: \mu_2 = \mu_3 = \mu_4$$

Significance level (That at least one is different): 99.81%

Case 4 is significantly better than the others.

$$H_0: \mu_2 = \mu_3$$

Significance level (That at least one is different): 96.86 %

Case 2 is significantly better than 3.

Ranking (worst – best): 1 – 3 – 2 - 4

7.3.2.2 *Commando Raid MOP Results and Statistical Analysis*

Figure 146 and Figure 147 are the box plots for the MOP's of the commando raid scenario: Force Exchange Ratio and number of penetrations. For all of the tests below, H_0 is the null hypothesis, that all of the cases tested have the same means μ_i . H_a is the alternative – that at least one of the μ_i 's is different. H_a is accepted when the difference between the means is statistically significant.

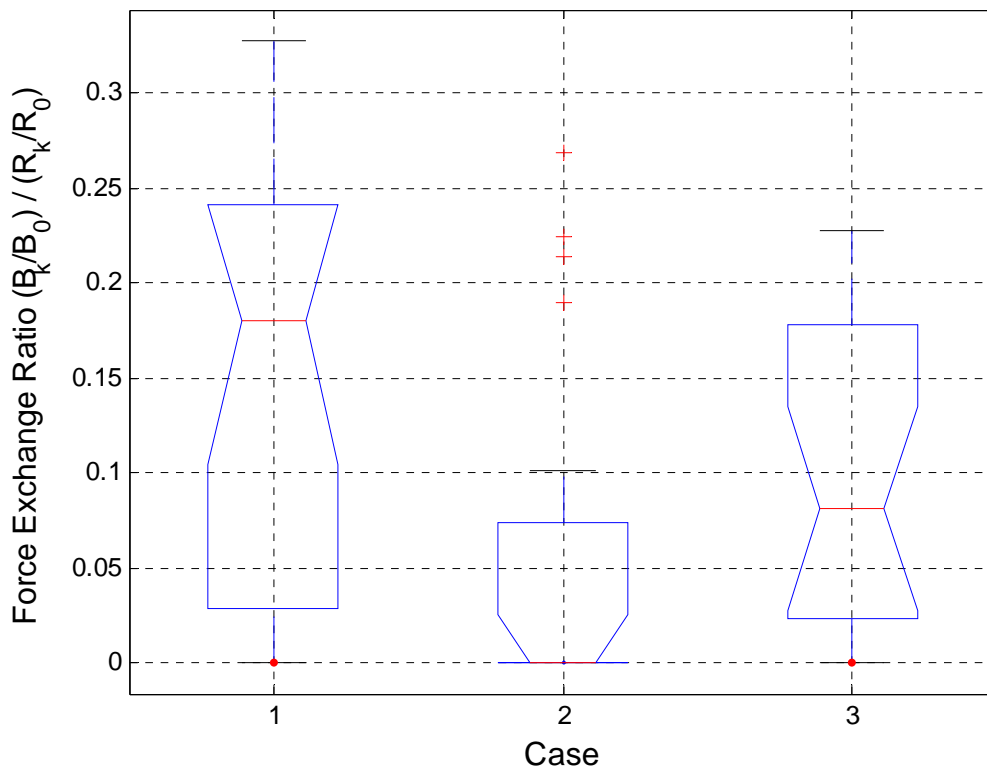

Figure 146. Force exchange ratio (B killed / B₀) / (R killed / R₀)

The order of the case numbers corresponded to the following architectures: 1, baseline raid defense; 2, baseline defense with mortar and sensor fence; 3, ROSAMs. The Kruskal-Wallis analysis was conducted as indicated:

$$\mathbf{H}_0: \mu_1 = \mu_2 = \mu_3$$

Significance level (That at least one is different): 99.55%

Case 1 is significantly worse than the others.

$$\mathbf{H}_0: \mu_2 = \mu_3$$

Significance level (That at least one is different): 97.1%

Case 2 is significantly better.

Ranking (worst – best): 1 – 3 - 2

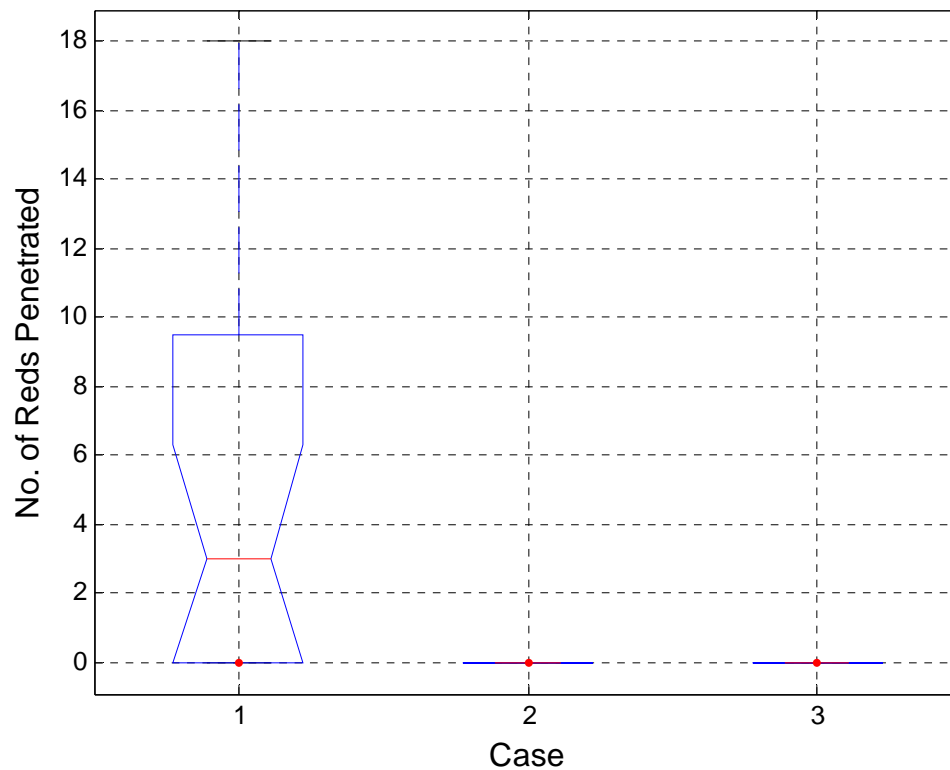

Figure 147. Number of Red Penetrations

The case numbers are the same as the box plot of the Force Exchange Ratio above.

$$\mathbf{H_0: } \mu_1 = \mu_2 = \mu_3$$

Significance level (That at least one is different): > 99.99%

Case **1** is significantly worse than the others.

$$\mathbf{H_0: } \mu_2 = \mu_3$$

The same – no penetrations occurred.

Ranking (worst – best): 1 – 2, 3

7.3.2.3 Boat Attack on FOB Results and Statistical Analysis

Figure 148 through Figure 150 are the box plots for the MOP's of the boat attack on the FOB scenario: mean distance of detected reds/ casualty location of reds, number of blue casualties, and SURC's destroyed. For all of the tests below, H_0 is the null hypothesis, that all of the cases tested have the same means μ_i . H_a is the alternative – that at least one of the μ_i 's is different. H_a is accepted when the difference between the means is statistically significant.

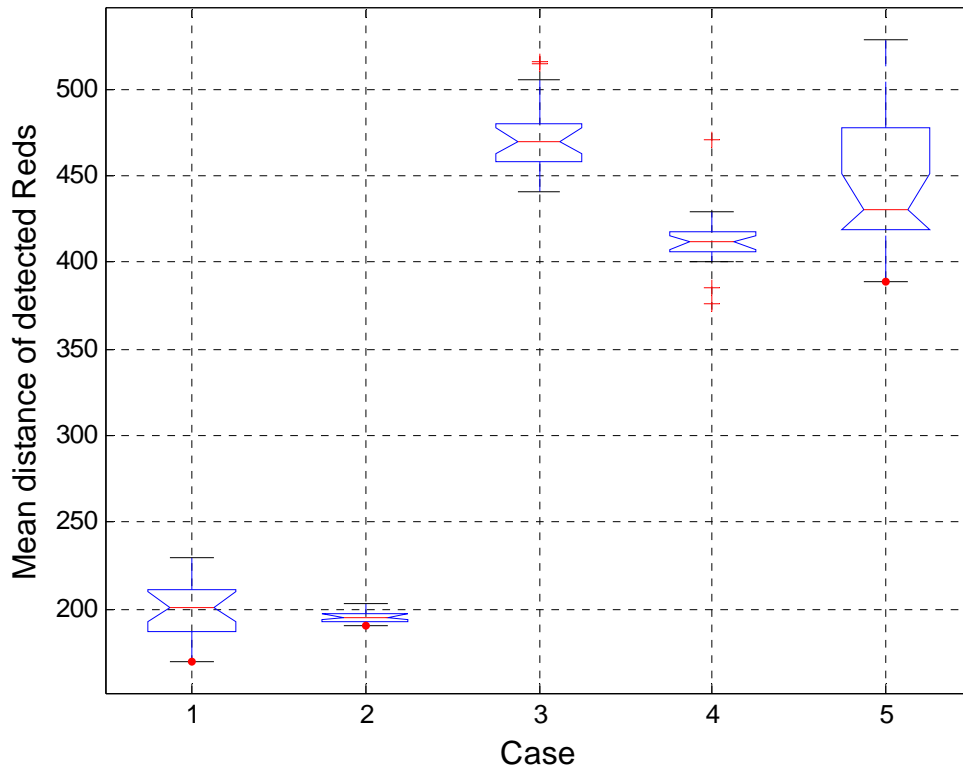

Figure 148. Mean distance of Red Casualties

The order of the case numbers corresponded to the following architectures; 1, baseline FOB boat defense; 2, baseline with floating barrier, 3, ROSAMs and floating barrier; 4, baseline, floating barrier, and PB; and 5, ROSAMs, floating barrier, and PB. The Kruskal-Wallis analysis was conducted as indicated:

$$\mathbf{H}_0: \mu_1 = \mu_2 = \mu_3 = \mu_4 = \mu_5$$

We should accept \mathbf{H}_a with a significance level: > 99.99%

1, 2 are significantly worse then 3, 4, 5.

$$\mathbf{H}_0: \mu_1 = \mu_2$$

Significance level for \mathbf{H}_a (That they are different): 84.05%

→ Not significantly different.

$H_0: \mu_3 = \mu_4 = \mu_5$

Significance level (That at least one is different): > 99.99%

3 is significantly better than 4, 5.

$H_0: \mu_4 = \mu_5$

Significance level (That they are different): 99.95%

4 is significantly worse than 5.

Ranking (worst – best): 1, 2 - 4 - 3

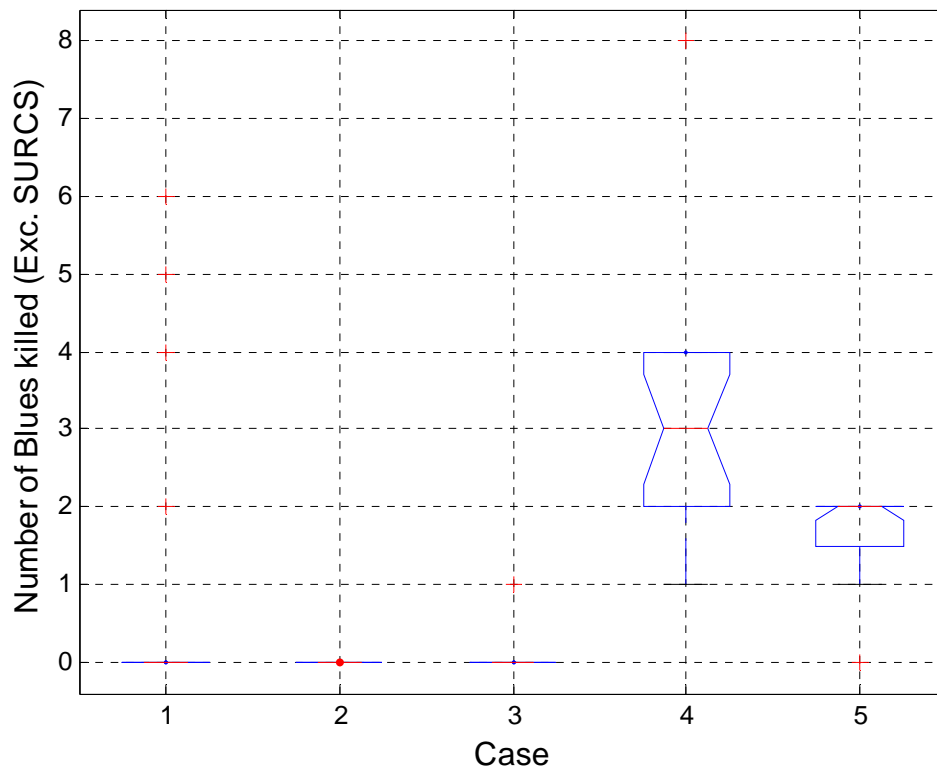

Figure 149. Number of Blue casualties, Excluding SURC's

The case numbers represent the same architectures as in the mean distance of casualty location plot.

$$\mathbf{H_0: } \mu_1 = \mu_2 = \mu_3 = \mu_4 = \mu_5$$

Significance level (That at least one is different): > 99.99%

Cases **1, 2, 3** are significantly better than 4, 5.

$$\mathbf{H_0: } \mu_1 = \mu_2 = \mu_3$$

Significance level (That at least one is different): 90.29%

Case **1** has few (positive) outliers – hence it is worse than 2, 3

$$\mathbf{H_0: } \mu_2 = \mu_3$$

Significance level (That at least one is different): 84.81%

→ No significant difference

$$\mathbf{H_0: } \mu_4 = \mu_5$$

Significance level (That at least one is different): 99.78%

5 is significantly better than **4, 5**.

Ranking (worst – best): 4 – 5 – 1 – 3, 2

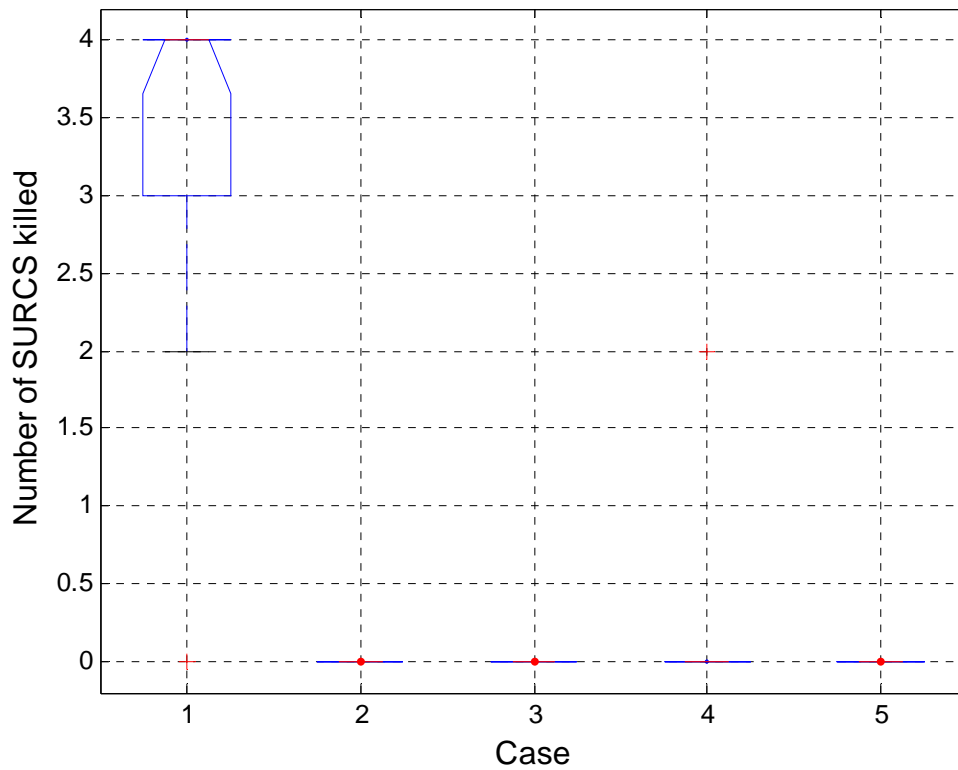

Figure 150. Number of SURC's Destroyed

$$H_0: \mu_1 = \mu_2 = \mu_3 = \mu_4 = \mu_5$$

Significance level (That at least one is different): 100%

Case 1 is significantly worse than the others.

$$H_0: \mu_2 = \mu_3 = \mu_4 = \mu_5$$

Significance level (That at least one is different): 60.84%

→ No significant difference

Ranking (worst – best): 1 – 2, 3, 4, 5

7.3.2.4 Boat Attack on MOB Results and Statistical Analysis

Figure 151 through Figure 153 are the box plots for the MOP's of the boat attack on the MOB scenario: mean distance of detected reds/ casualty location of reds, number of blue casualties, and SURC's destroyed. For all of the tests below, H_0 is the null hypothesis, that all of the cases tested have the same means μ_i . H_a is the alternative – that at least one of the μ_i 's is different. H_a is accepted when the difference between the means is statistically significant.

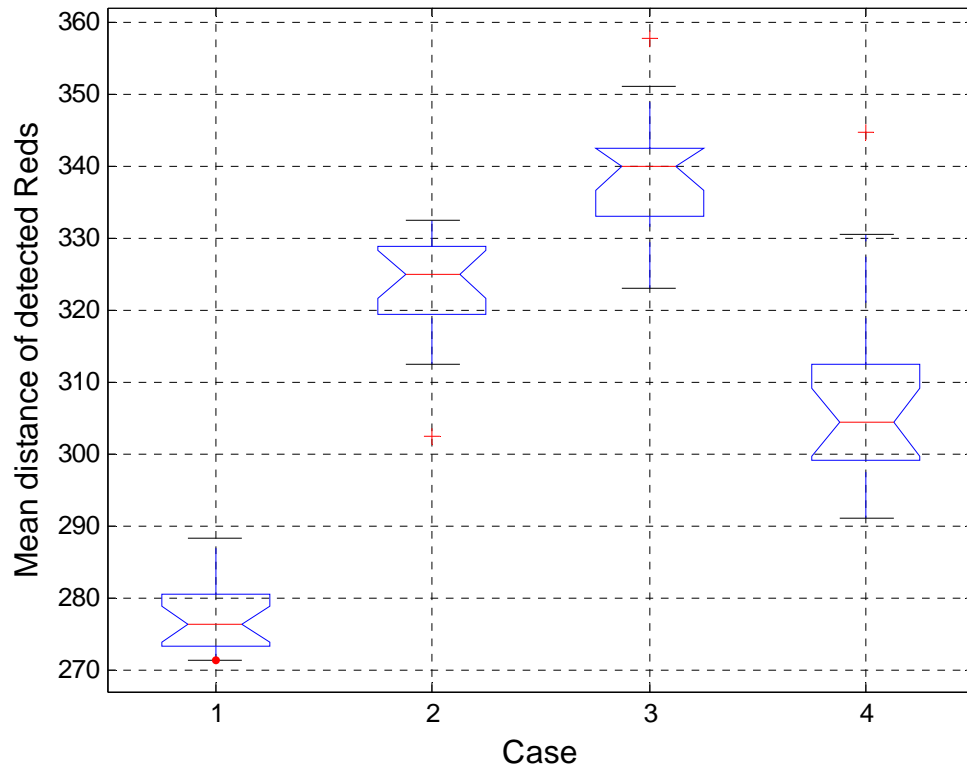

Figure 151. Mean Distance of Red Casualties

The order of the case numbers corresponded to the following architectures; 1, baseline RCSS; 2, RCSS with PB, 3, Nobriza and Barge baseline; and 4, Nobriza and Barge baseline with floating barrier and PB. The Kruskal-Wallis analysis was conducted as indicated:

$$H_0: \mu_1 = \mu_2 = \mu_3 = \mu_4$$

Significance level (That at least one is different): > 99.99%

Case 1 is significantly worse than the others.

$$H_0: \mu_2 = \mu_3 = \mu_4$$

Significance level (That they are different): >99.99%

Case 4 is significantly worse than 2, 3.

$$H_0: \mu_2 = \mu_3$$

Significance level (That at least one is different): > 99.99%

Case 2 is significantly worse than 3.

Ranking (worst – best): 1 – 4 – 2 - 3

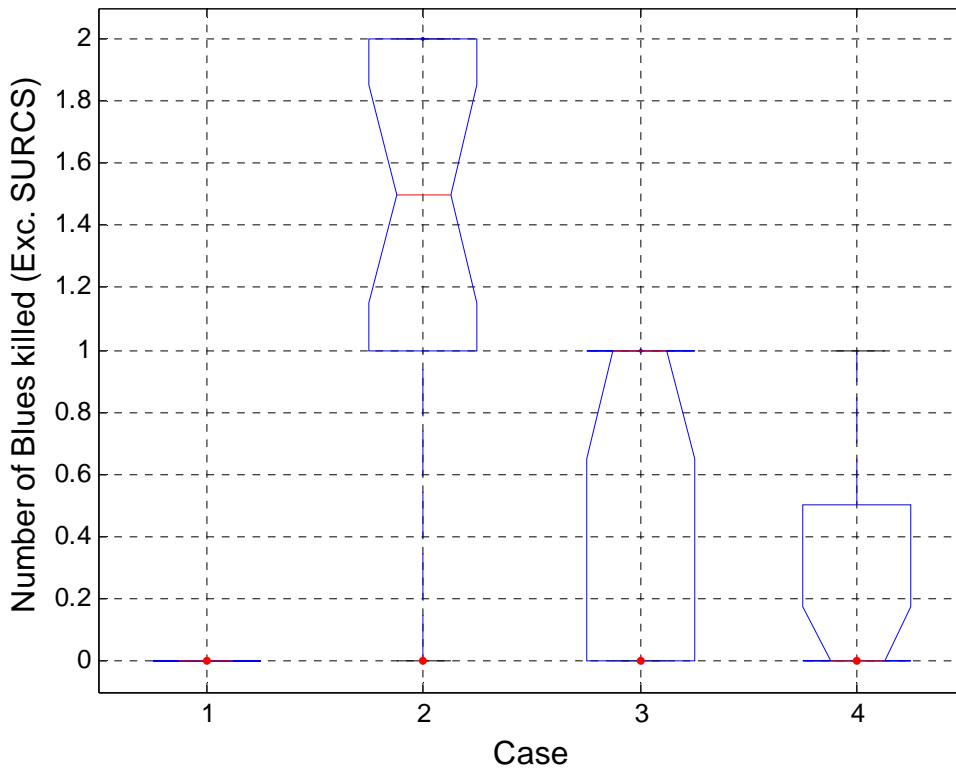

Figure 152. Number of Blue Casualties, excluding SURC's

The case numbers represent the same architectures as in the mean distance of casualty plot.

$$\mathbf{H_0: } \mu_1 = \mu_2 = \mu_3 = \mu_4$$

Significance level (That at least one is different): >99.99%

Case **1** is significantly better than the others, and **2** is significantly worse.

$$\mathbf{H_0: } \mu_3 = \mu_4$$

Significance level (That at least one is different): 94.41%

Case **3** is significantly worse than **4**.

Ranking (worst – best): 2 – 3 – 4 – 1

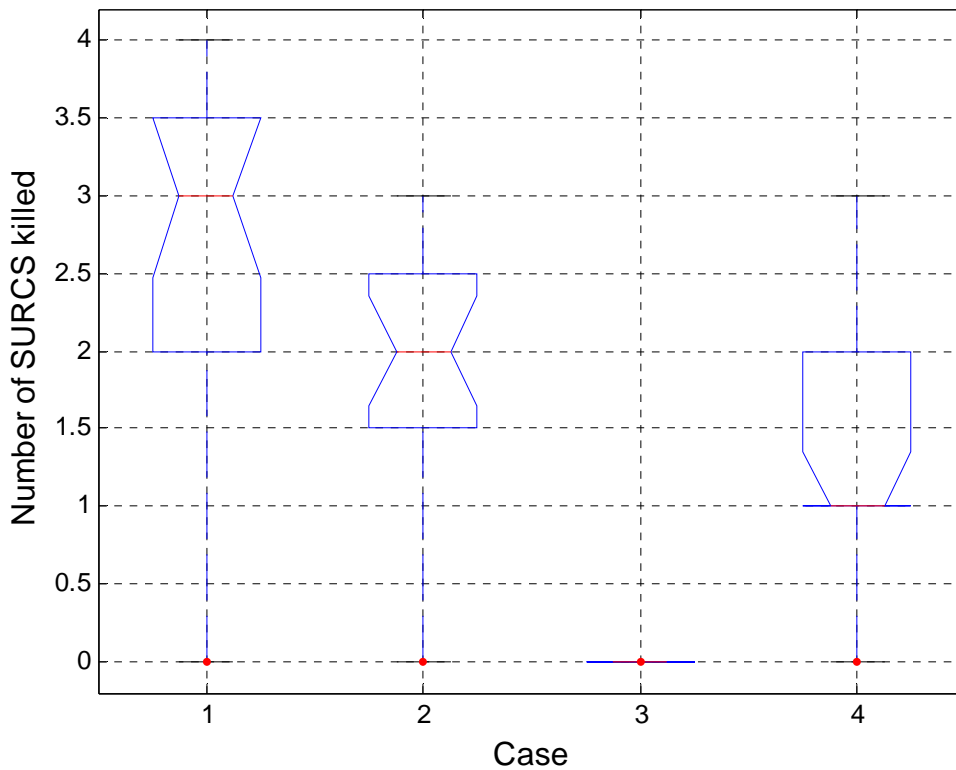

Figure 153. Number of SURC's destroyed

$$\mathbf{H_0: } \mu_1 = \mu_2 = \mu_3 = \mu_4$$

Significance level (That at least one is different): >99.99%

Case 3 is significantly better than the others.

$$\mathbf{H_0: } \mu_1 = \mu_2 = \mu_4$$

Significance level (That at least one is different): = 99.95%

Case 1 is significantly worse than 2, 4.

$$\mathbf{H_0: } \mu_2 = \mu_4$$

Significance level (That at least one is different): = 96.4%

Case 2 is significantly worse than 4.

Ranking (worst – best): 1 - 2 – 4 - 3

7.3.3 Raw Data Matrices, Alternative Rankings, and Sensitivity Analysis

At the conclusion of the MOP statistical analysis, Raw Data Matrices were formed for each scenario based off of the measured medians. The architectures that had no statistical difference in their MOP were given equivalent medians so that there would be no difference in performance.

The data was normalized using a linear relationship and the following formulas. For data where a higher value was worse, the following formula was used:

$$\left(\frac{MaxValue - AlternativeData}{MaxValue - MinValue} \right) * 100$$

For data where a higher value was desired, the following formula was used:

$$\left(\frac{AlternativeData - MinValue}{MaxValue - MinValue} \right) * 100$$

For each MOP, the MaxValue and MinValue changed.

After data normalization, weights were assigned to each MOP so a utility score comprised of all MOP's for an alternative could be generated. The alternative ranking

for the architectures of each scenario was based off this utility score, but the rankings were also checked for sensitivity based on the weights assigned.

7.3.3.1 Mortar Defense Alternatives

Table 84 is the Raw Data Matrix for the Mortar threat architectures.

Mortar Defense	Time to detect	Number of hits received
Baseline (already in RF)	600	24
Mortar and UAV	150	5
Mortar and LCMR	150	8
Mortar, LCMR, UAV	150	2

Table 84. Raw Data Matrix for Mortar Defense Architectures

This data was normalized using the higher-is-worse equation for both MOPs. The MaxValue for time to detect was assumed to be 600, while the MinValue was 60. The MaxValue for the number of hits received was 30, as this was the most mortar rounds the enemy could carry in this scenario, and the MinValue was 0. Table 85 is the normalized data matrix.

Mortar Defense (normalized)	Time to detect	Number of hits received
Baseline (already in RF)	0	20
Mortar and UAV	83	83
Mortar and LCMR	83	73
Mortar, LCMR, UAV	83	93

Table 85. Normalized Data Matrix for Mortar Defense

Weights were assigned to the MOPs to generate an alternative scoring among the mortar defense alternatives, although from the normalized data matrix there is a clear increase in performance down the matrix as the time to detect remained constant and the number of hits received varied. The RST reasoned that the number of hits is four times as important of a MOP for mortar defense as time to detect, so a weight of .8 was assigned to the number of hits MOP, while .2 was assigned to the time to detect MOP.

With the assigned weights, utility scores for each alternative were developed. Table 86 is the utility scores for each of the mortar defense alternatives.

Mortar Defense	Utility Scores
Baseline (already in RF)	16
Mortar and UAV	83
Mortar and LCMR	75
Mortar, LCMR, UAV	91

Table 86. Mortar Defense Utility Scores

The utility score confirmed what was already apparent for these alternatives because there were only two MOP's and the performance of the alternatives were consistent across the MOP's. Sensitivity analysis did not have to be performed for these alternatives because the results were clearly insensitive based on the data presented earlier.

7.3.3.2 *Commando Raid on FOB*

Table 87 is the raw data matrix for the Commando Raid architectures.

Commando Raid	Force Exchange Ratio	Number of Penetrations
Baseline	0.17	3
Baseline, Sensor Fence, and Mortar	0	0
ROSAMS	0.07	0

Table 87. Raw Data Matrix for Commando Raid Architectures

Much like the mortar alternatives, there is a clear delineation of performance here. The baseline, Sensor Fence, and Mortar alternative was the highest performing, while the ROSAMs architecture was second followed by the baseline. Data normalization and utility scoring were still conducted in similar fashion as the Mortar scenario to arrive at a utility score for use in efficiency curves.

Also like the mortar scenario, both of the MOPs for this scenario represent less performance with higher numbers in the raw data matrix. The MaxValue assumed for the Force Exchange Ratio was .5 as this would represent a significant loss to the blue force. The MinValue for the Force Exchange Ratio was 0. The MaxValue of infiltrations for the scenario was 10, as this would represent 10% of the attacking insurgents infiltrating the camp. The MinValue was, of course, 0. Table 88 is the normalized data matrix for the commando raid alternatives.

Commando Raid (normalized)	Force Exchange Ratio	Number of Penetrations
Baseline	66	70
Baseline, Sensor Fence, and Mortar	100	100
ROSAMS	86	100

Table 88. Normalized Data Matrix for Commando Raid Alternatives

The RST assigned a weight of .7 to the FER and .3 to the number of infiltrations for the utility scoring. Table 89 is the utility scoring for each of the commando raid alternative FPSs.

Commando Raid	Utility Score
Baseline	69
Baseline, Sensor Fence, and Mortar	100
ROSAMS	96

Table 89. Commando Raid Utility Scores

Sensitivity analysis was not necessary to perform as the performance of each alternative was consistent across all MOPs.

7.3.3.3 FOB Boat Attack Alternatives

Table 90 is the raw data matrix for the FOB Boat Attack alternatives.

FOB Boat Attack	Mean distance of detected reds	Number of blue casualties	Number of SURCS destroyed
Baseline	200	0.5	4
Baseline and Water Barrier	200	0.0	0
Water barrier and ROSAM	470	0.0	0
Baseline Water Barrier and PB	410	3.0	0
ROSAM Water Barrier and PB	425	2.0	0

Table 90. Raw Data Matrix for FOB Boat Attack Architectures

In this data matrix, the higher number of mean distance of detected reds was favorable, while number of blue casualties and number of SURC's destroyed were desired to be low. It was clear from the raw data matrix that the water barrier and ROSAM alternative is the best performer, and the baseline was the worst performer. The other alternatives having varying degrees of performance across MOP's. Table 91 is the normalized data matrix.

FOB Boat Attack (normalized)	Mean distance of detected reds	Number of blue casualties	Number of SURCs destroyed
Baseline	39	90	0
Baseline and Water Barrier	39	100	100
Water barrier and ROSAM	94	100	100
Baseline Water Barrier and PB	82	40	100
ROSAM Water Barrier and PB	85	60	100

Table 91. Normalized Data Matrix for FOB Boat attack

The MaxValue and MinValue for distance was 500 and 0, respectively. Five hundred was set as the beginning of an exclusion zone around the base, so once an unknown boat crossed this line they were considered a threat. The MaxValue for number of blue casualties was 5, and the MinValue 0. The RST considered five casualties to be a worst case number as this was almost half of the 11 blue personnel that could be in the scenario (8 on the MG's along the river bank and three in the patrol boat). The MaxValue for the number of SURC's destroyed was 4 and the MinValue was 0, as the number of moored SURC's was 4. Table 92 is the utility scores assigned for the FOB Boat Attack architectures.

FOB Boat Attack	Utility Scores
Baseline	40
Baseline and Water Barrier	94
Water barrier and ROSAM	99
Baseline Water Barrier and PB	74
ROSAM Water Barrier and PB	82

Table 92. Utility Score for FOB Boat Attack

The utility scores were derived with a weight of .5 for the damaged SURC's, .4 for blue casualties, and .1 for the mean distance of detected reds/ red casualties. It was necessary to conduct sensitivity analysis on the alternatives because the inconsistency of the MOP's for the different architectures.

7.3.3.4 MOB Boat Attack Alternatives

Table 93 is the raw data matrix for the FOB Boat Attack alternatives.

MOB Boat Attack	Mean distance of detected reds	Number of blue casualties	Number of SURCS destroyed
RCSS Baseline	275	0	3
RCSS and PB	326	1.5	2
Nobriza and Barge Baseline	340	1	0
Nobriza and Barge Baseline, PB, and Water Barrier	304	0.1	1

Table 93. Raw Data Matrix for MOB Boat Attack Architectures

In this data matrix, the higher number of mean distance of detected reds was favorable, while number of blue casualties and number of SURC's destroyed were desired to be low. There was no clear alternative that performed the best from this data matrix. Table 94 is the normalized data matrix.

MOB Boat Attack (normalized)	Mean distance of detected reds	Number of blue casualties	Number of SURCS destroyed
RCSS Baseline	55	100	25
RCSS and PB	65.2	70	50
Nobriza and Barge Baseline	68	80	100
Nobriza and Barge Baseline, PB, and Water Barrier	60.8	98	75

Table 94. Normalized Data Matrix for MOB Boat attack

The MaxValue and MinValue for distance was 500 and 0, respectively. Five hundred was set as the beginning of an exclusion zone around the MOB, so once an unknown boat crossed this line they were considered a threat. The MaxValue for number of blue casualties was 5, and the MinValue 0. The RST considered 5 casualties to be a worst case number as this was almost half of the 11 blue personnel that could be in the scenario (8 manning the weapons on the MOB and three in the patrol boat). The MaxValue for the number of SURC's destroyed was 4 and the MinValue was 0, as the number of moored SURC's was 4. Table 95 is the utility scores assigned for the FOB Boat Attack architectures.

MOB Boat Attack	Utility Score
RCSS Baseline	58
RCSS and PB	60
Nobriza and Barge Baseline	89
Nobriza and Barge Baseline, PB, and Water Barrier	83

Table 95. Utility Score for MOB Boat Attack

The utility scores were derived with a weight of .5 for the damaged SURC's, .4 for blue casualties, and .1 for the mean distance of detected reds/ red casualties. It was necessary to conduct sensitivity analysis on the alternatives because the inconsistency of the MOP's for the different architectures.

7.3.3.5 MANA Results

Figure 154 represents the results of the first five MATLAB scenarios that dealt specifically with the combat stage of the model and consisted of the various configurations of weapons, bunkers, machine guns, and IR illuminators.

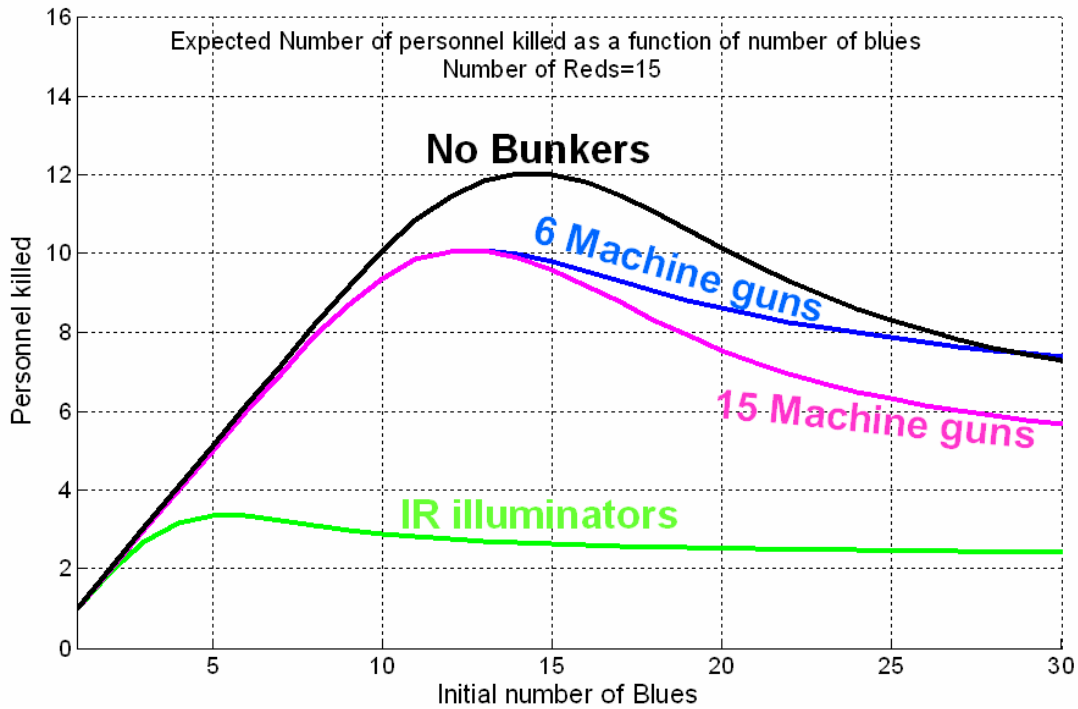

Figure 154. MATLAB Combat Stage Results

The top curve represented six machine guns and no bunkers. The bottom three curves all assumed the use of bunkers. The IR illuminator curve also assumed six machine guns.

The graph demonstrated IR illuminators were the most valuable asset for perimeter defenses. If less Blue personnel were employed bunkers were also valuable, but as the number of Blue personnel increased, machine guns became more valuable.

Scenario six of the MATLAB analysis was derived the value of IR sensors. This scenario was only applied to the sensing and detection stage of the model, so the lives saved were from those spared from a surprise attack by the enemy. Figure 155 represents the graph depicting the performance of the sensors. The graph shows approximately five lives could be saved by employing nine or more sensors.

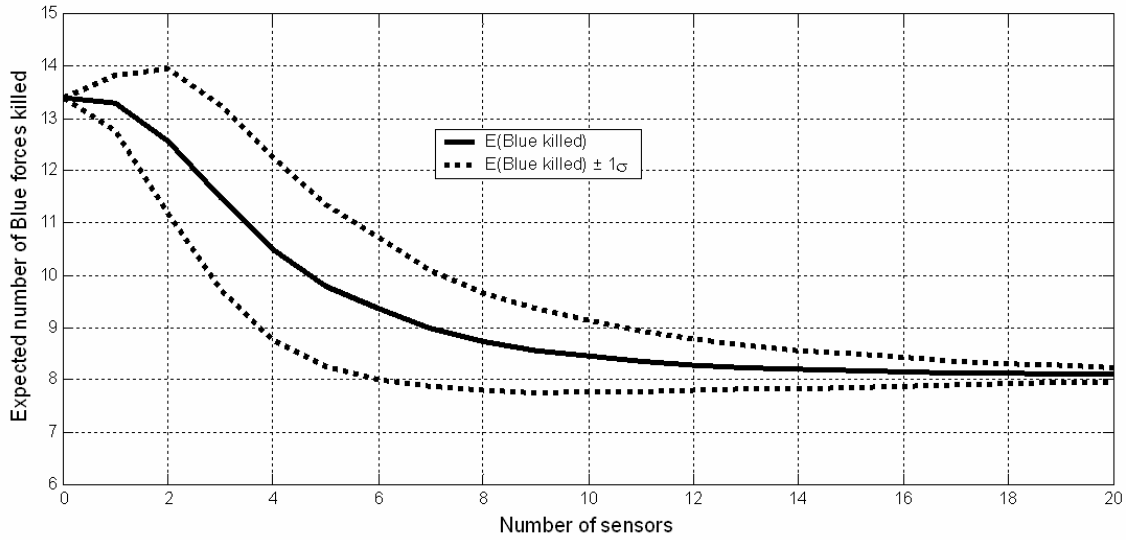

Figure 155. Value of IR Sensors

7.3.4 Cost Performance Curves

The RST used the original utility scores and the cost estimations for each architecture to create cost performance curves that showed the cost versus performance for the different architectures in each scenario. Figure 156 is the cost performance curve for the mortar defense alternatives.

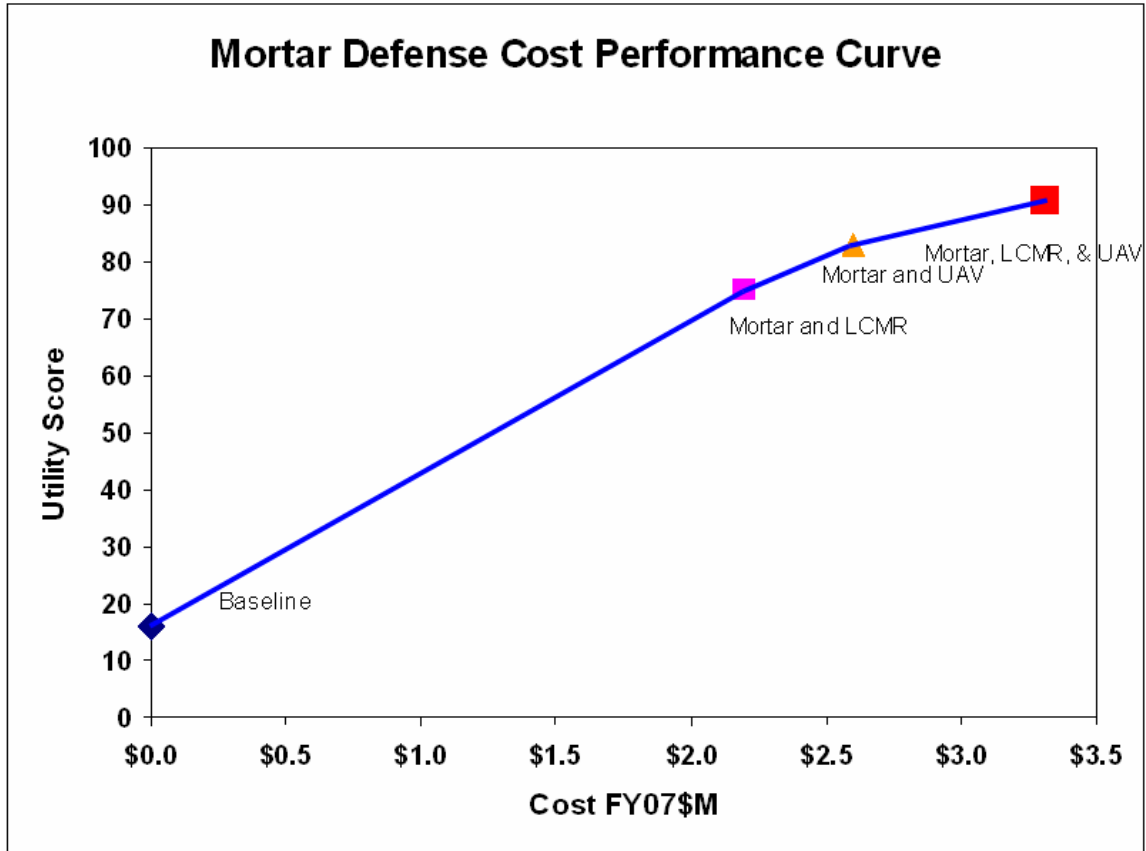

Figure 156. Mortar Defense Cost Performance Curve

The cost performance curve for mortar defense demonstrated an almost linear relationship between the utility score for each architecture and their associated cost. Because of this almost linear relationship, there is no clear alternative that provides the best “bang for the buck” Figure 157 is the cost performance curve for the Commando Raid Architectures.

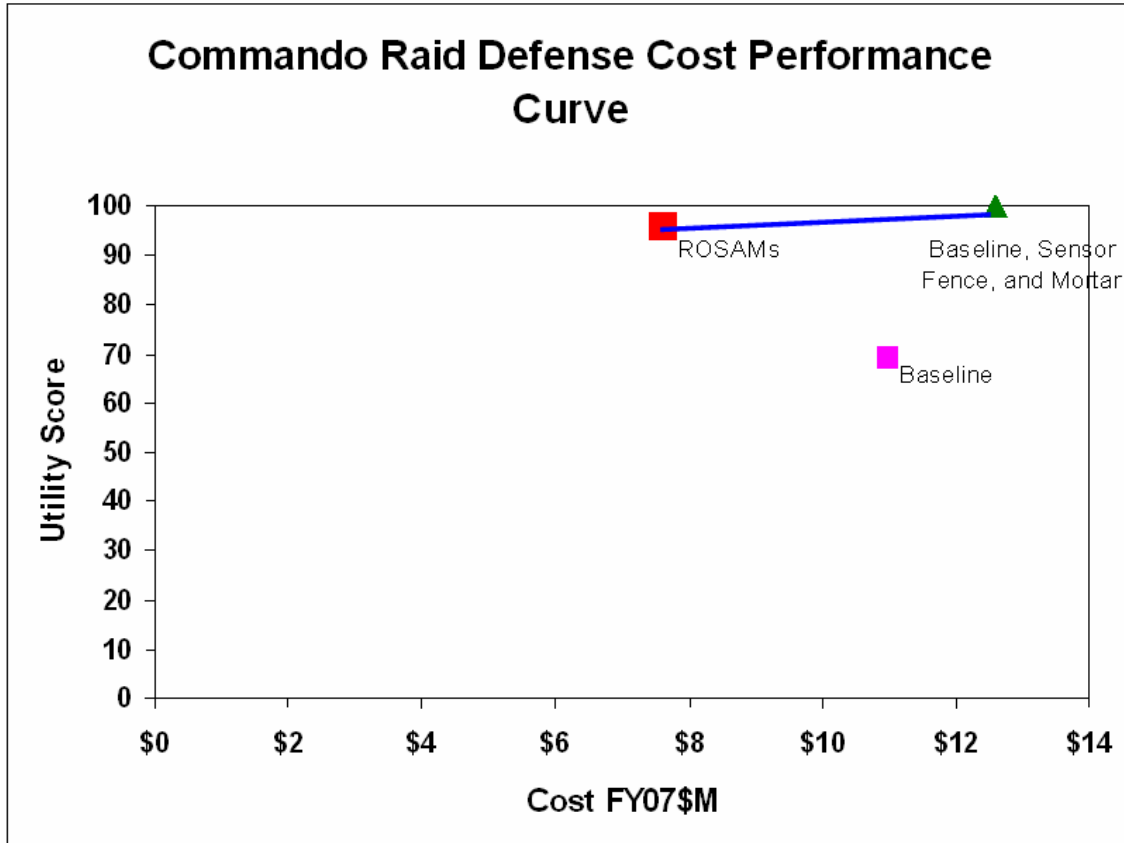

Figure 157. Commando Raid Alternatives Cost Performance Curve

The cost performance curve for the commando raid defense reveals that the ROSAMs are the clear choice for most “bang for the buck.” The ROSAMS had a high utility because their use resulted in fewer RF personnel casualties. The baseline architecture was dominated by the ROSAMs in that it was more expensive and did not perform as well as indicated by its low utility score. Figure 158 is the cost performance curve for the boat attacks on the FOB alternatives.

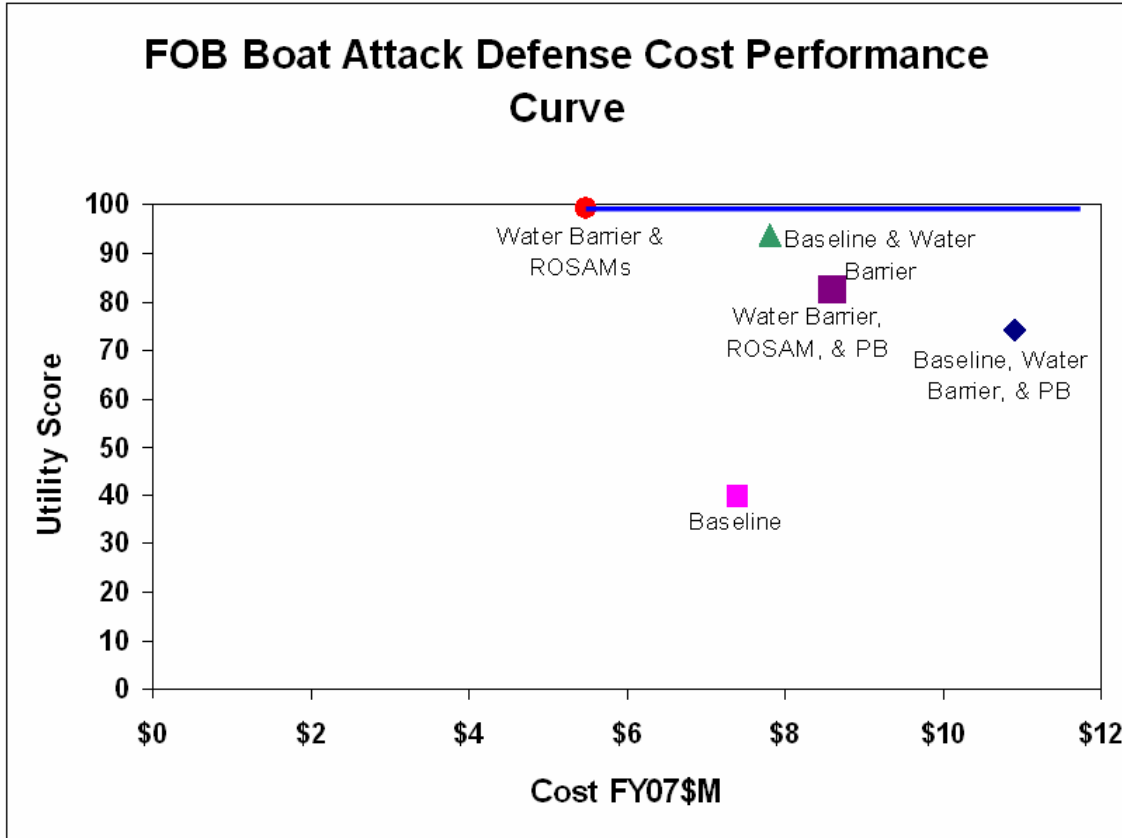

Figure 158. FOB Boat Attack Cost Performance Curve

The Water Barrier and ROSAMs dominated all other alternatives because it was the highest performing and lowest cost. The lack of personnel had a double effect for this alternative. Not only were less blue forces killed, thus increasing the survivability of this alternative, but the O&S costs were reduced because the manning requirement was less.

Figure 159 is the cost performance curve for MOB Boat Attack alternatives.

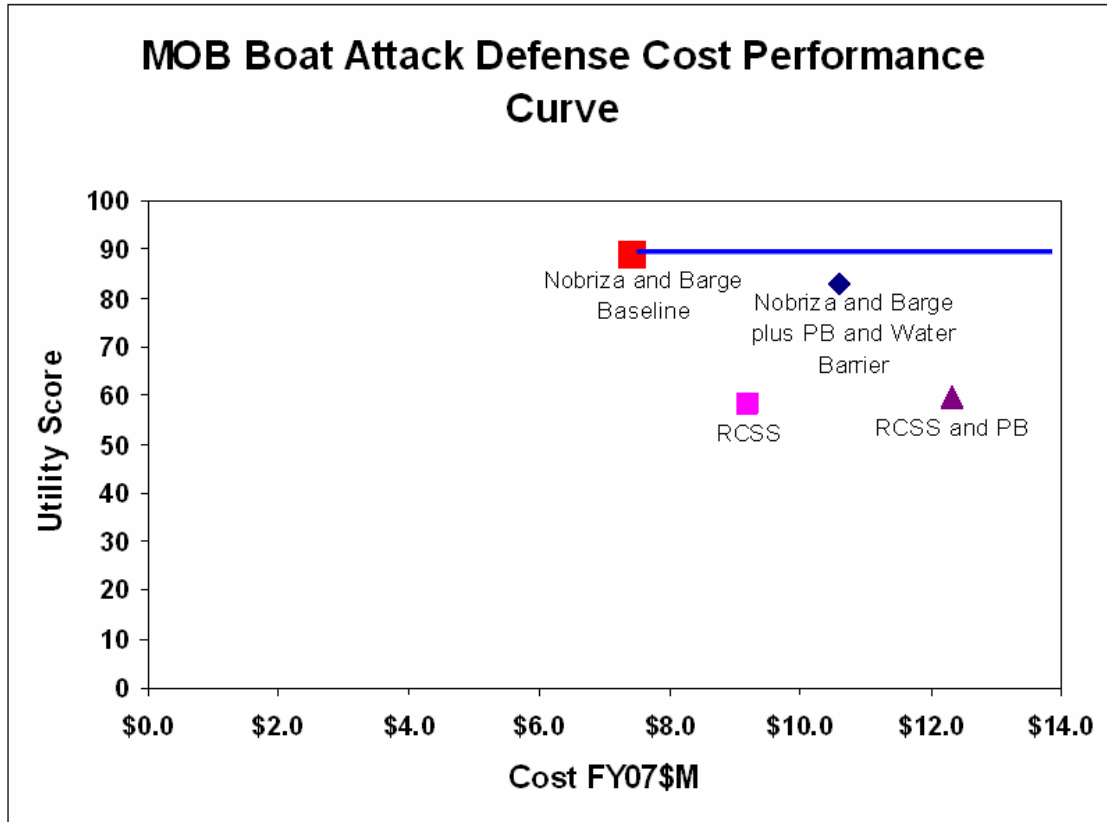

Figure 159. MOB Boat Attack Defense Cost Performance Curve

The Nobriza and Barge baseline was clearly most cost effective in this scenario. The operating and support cost for the Nobriza and Barge were less because there were less weapon manning requirements than the RCSS. The Nobriza provided heavy fire power without having to use the more vulnerability patrol boats, so the utility was higher for this architecture.

⁴²⁹ Adams, Christopher M. “Inventory Optimization Techniques, System vs. Item Level Inventory Analysis.” *Reliability and Maintainability 2004 Annual Symposium - RAMS* (2004). http://ieeexplore.ieee.org/xpls/abs_all.jsp?arnumber=1285423.

⁴³⁰ U.S. Special Operations Command, *Operational Requirement Document (ORD) for the Special Operations Craft- Riverine (SOC-R)*, 5 January 1998 (Washington, DC: GPO, 1998), 5.

⁴³¹ Jay L. Devore, *Probability and Statistics for Engineering and the Sciences*, 6th ed. (Belmont, CA: Thomson Learning, 2004), 689.

THIS PAGE INTENTIONALLY LEFT BLANK

8. CONCLUSIONS AND RECOMMENDATIONS

8.1 SUPPLY GROUP

Key factors of riverine sustainment supply success are supply ship cycle time, basing alternative, logistics connector survivability, operational availability of the SURC's and cost. Given the supply ship cycle time, basing alternative, and number of assets used, the RST was able to determine the most effective configuration of connectors.

Helicopters added very little to the overall performance of the configuration of connectors, but they increase the cost significantly. If the RF operates from a FOB with a supply ship cycle time between 4-7 days, then the most effective connector is the LCU-2000. This is because the LCU-2000 can carry the entire supply load in one run. When the supply ship cycle time increases to 8-9 days, then the LCU-2000 can no longer carry the entire supply load in one run. Instead, the Jim G becomes the most effective connector. This is assuming that the RF would have to procure an LCU-1610 and LCU-2000. If the procurement of the two crafts is not necessary, then the LCU-2000 with an LCU-1610 would be the most cost effective configuration. If only one vessel is used, then the Jim G will allow the maximum supply ship cycle time to maintain a 95% operational availability of SURC's due to fuel if the supply ship cycle time is not specified.

If the RF operates from a Nobriza+Barge MOB with a supply ship cycle time between 4-7 days, then the most cost effective connector is the LCU-2000. Similar to the FOB, the Nobriza+Barge requires a seven day supply load that can fit in the LCU-2000. When the supply ship cycle time increases to 8-9 days, then the LCU-2000 with an LCU-1610 is the most effective configuration. Unlike the FOB, the Nobriza+Barge requires a slightly greater supply load that would require a LCU-2000 and a Jim G to do multiple runs. If only one vessel is used, then the Jim G will allow the maximum supply ship cycle time to maintain a 95% operational availability of SURC's due to fuel if the supply ship cycle time is not specified.

If the RF operates from the RCSS, Endurance, or Sri Inderapura MOB with a supply ship cycle time between 4-7 days, then the most effective configuration of connectors is a Jim G with an LCU-1610. The increase in supply load compared to the other basing alternatives requires multiple runs when a single Jim G or two LCU-1610's are used. When a Jim G and an LCU-1610 are combined, they can re-supply the MOB in one run. When the ship cycle time increases to 8-9 days, then two Jim G's is the most effective configuration. If only one vessel is used, then the Jim G will allow the maximum supply ship cycle time to maintain a 95% operational availability of SURC's due to fuel if the supply ship cycle time is not specified.

For a single connector, the Jim G supported the best supply ship cycle time. If the RF wants to only use one Jim G while having the maximum supply ship cycle time, then the RF should operate from a FOB because of its lower supply demand.

8.2 REPAIR GROUP

Increasing personnel, maintenance bays, or SURC did not have a significant effect on improving operational availability with the repair model, and with this in mind it is recommended that the status quo remain in place. However, when considering the RST scenario constraint of maintaining at least 9 mission ready SURC's at all times, the alternative of increasing both personnel and maintenance bays was the cheaper than procuring additional SURC's. Also, the model indicated that MSRT was the biggest factor that affected SURC operational availability. MSRT's exceeding 24-hours drove operational availabilities below 80%. Given a logistically barren environment as presented in the RST scenario, it is vital that an exhaustive PUK is developed for the RF. This PUK must not only contain high failure rate items, but also items that fail at moderate rates.

Despite not predicting any significant difference between the baseline status quo and the alternatives, the model developed by the repair model can serve as a planning tool for future riverine warfare operations. As key parametric changes can be easily implemented within the model, such as environmental concerns, Commander's discretion, medical problems, and so forth, the Repair Group's model has established a

foundation upon which such studies can be made. Furthermore, with regard to every alternative, including the status quo, being very sensitive to MSRT, the repair model may serve as a tool for repair re-supply planning and evaluation of logistics alternatives that involve faster connectors such as airlift.

8.3 FORCE PROTECTION GROUP

The analysis conducted in the scenarios revealed some key insights. The first insight revealed was that the current mortar defenses proposed by the RF are insufficient. The analysis conducted in this study was with the aide of a host nation providing security beyond the FOB's perimeters out to the expected mortar range. Even though the best alternative improved on the baseline by severely decreasing the number of mortar rounds that hit the base, the modeling showed that three mortar rounds still struck the base. This means that even with the mortar defenses proposed in this study, the FOB could expect to be hit by mortar rounds each time they are attacked. If the RF is to based at the a FOB ashore, then the host nation needs to provide robust perimeter defense. For the decision maker deciding which basing alternative to consider, this is a major consideration because a MOB can move and prove less susceptible to mortar fire, especially with as wide a river as the Kampar.

The analysis also revealed that the ROSAMs were an excellent resource for force protection in two different scenarios. The ROSAMs provide a reduction in manpower, which decreased the RF footprint and also promoted greater RF survivability when the FOB was attacked.

The MOB boat attack scenarios revealed that the Nobriza and Barge were the most cost effective means to defend the RF when they were operating from a MOB. The Nobriza provided excellent firepower without the added exposure to personnel, which was discovered to be a draw back for a patrol boat.

The MATLAB analysis revealed that for the perimeter defenses, IR illuminators coupled with the NVG's are very valuable assets. The RF should also consider using acquiring RDFW units for the creation of bunkers.

8.4 COMMUNICATIONS TECHNOLOGY

Tactical communications equipment used by riverine forces needs to continue on a path of modernization and increased capacity. Current technology used by riverine forces, though mature in its development, is based on technology requirements and operational doctrine which support a narrow view of what a communications system should do. Development of new technologies in communications is progressing at a rapid rate and warrants a closer look into their applications for use in tactical environments.

A technology search found that advances in Worldwide Interoperability for Microwave Access (WiMAX) technology hold great potential for advancing the communications and information sharing capacity of riverine forces operating in a tactical environment.

Since WiMAX technology is a commercial off the shelf product, it holds promise as a more readily available and lower cost solution for tactical communications networks. Its development around the needs of corporate industry to increase their communications and information throughput at greater distances than standard wireless networks parallels the riverine forces needs for greater throughput of the same in support of their operations. The ability of WiMAX to handle multiple types of communications simultaneously at high rates of throughput shows its potential to overcome current limits of bandwidth available to riverine forces.

9. AREAS OF FURTHER STUDY

The first Navy riverine squadron, RIVRON-ONE, was stood-up 2006 since the Vietnam Era. RIVRON-ONE was deployed to Iraq in February 2007 to relieve the Marine Corp's Dam Security Unit. The dynamic nature of this force lends itself to countless avenues of potential study. The RST chose to address the sustainment, which included supply, repair, and force protection. During the course of this study the RST unveiled several areas of study that were beyond the scope of this technical report. The RST categorized these areas of further study into six groupings: WIED's, riverine craft, supply, repair, force protection and communication.

The RST recognized that Waterborne Improvised Explosive Devices (WIED's) are a real and emerging threat to the RF. WIED's do not require much effort or technology to employ and could easily render the RF helpless. They can be floated down river or anchored to the river bank, in either case they are lethal and difficult to counter. Measures need to be developed to protect the FOB, MOB, and SURC's from these deadly devices.

Current U.S. Naval ship inventories do not adequately address the needs of the riverine squadron. The Navy does not have any ships that could provide an adequate mobile operating support base for the RF. A vessel that can travel in excess of 20 knots, has a displacement of less than 10 feet, can sustain a RF sized force of 224, is sufficiently armored, has a capacity for helicopters/UAV's, and can support all of the RF's C4ISR needs should be developed. The RST selected the LCU-2000 and Jim G as the best logistic connectors for the RF for their superior throughputs. However, both vessels traverse at speeds below 10 knots when fully loaded. These slow speeds hamper throughput and invite attack from hostile elements. A logistic vessel with the cargo capacity of the Jim G that is capable of transporting goods at speeds in excess of 20 knots should be examined. The SURC, like special warfare's SOC-R, is highly maneuverable and fast (speeds in excess of 40 knots) which makes it perfect for insertion/extraction missions where speed is important. However, the SURC is not the appropriate vessel for the riverine squadron's missions that require a persistent presence like most of the MSO

and TSC missions. Most of these missions require the riverine craft to patrol at speeds less than ten knots. The slower speeds make the SURC crews vulnerable to ambush and sniper fire. A riverine craft that is built like a tank, similar to the Swedish CB-90s, should be developed. All of these ideas were passed on to NPS's Total Ship Systems Engineering (TSSE) group for further study.

The RST identified areas for further study for supply, based on assumptions made for the scenario. The primary focus of this study dealt with re-supplying the RF with fuel, water, food, ammunition, and repair parts. The process that dealt with how supplies were stored and transported is recommended for further study, in particular fuel and water. Other areas of further study include the protection of the supply connectors and the ability of the RF to perform MEDEVAC and CASEVAC operations.

Fuel was stored in 900 gallon SIXCON's. Because of the amount of fuel required for the SURC's alone, further study may need to be done on bigger fuel tanks. Also, a more efficient way of transporting fuel, such as fuel tanks in the logistic connectors vice carrying SIXCON's on deck, is an area of further study.

Water was also stored in SIXCON's, and the RST looked at transporting potable water to the operating base. An area of further study is the use of water purification systems in the river in order to decrease the supply load. Current water purification systems for a riverine environment are very good at removing normal impurities of silt and debris plus any micro organisms. However, in determining the amounts of water to be moved up the river the RST discovered that there was no guarantee that highly polluted river water from paper factories and industrial waste was able to be removed from the water. This poses a serious health risk to the forces on the ground, especially in underdeveloped countries that have not developed laws to protect the environment.

The RST also recommends analyzing how to protect the supply connectors. From the study, the RST showed how re-supplying the RF in a timely manner is vital to the operation. Further study on the protection of the supply connectors is recommended. This protection is recommended to be organic to the logistic connector therefore assets

designate for the actual operation would not be taken from their primary mission to protect the logistic connectors.

Another area of further study is the ability of the RF to perform CASEVAC operations. The RST assumed that these operations would be done by the host nation, but the RF may not have the same support in a different scenario. The critical time for a casualty is how fast initial stabilization can be done. If stabilization can occur within the first hour after a casualty the personnel have a much higher chance of surviving. This ties in directly to develop a system that would be able to rapidly deploy and quickly retrieve personnel whether in the river or on land.

With regard to resource allocation and area-specific riverine logistics planning, the repair group found that the RF maintenance activities could be modeled after Naval Special Warfare Special Boat Teams as well as Naval Aviation Squadrons. An analysis into the pre-positioning of maintenance materiel, non-conventional logistics connectors, and the effect of key changes in maintenance doctrine on the utility of the aforementioned should greatly benefit the RF of the future. At present, the Repair Group is satisfied that Raytheon CLS is under contract to provide crucial reliability, maintainability and availability data on the Small Unit Riverine Craft; however, a more thorough analysis of the mean time between failure, mean time to repair by fault category (i.e., propulsion related faults, auxiliary, etc.), administrative delays, supply response times given certain logistics connectors, and the mean time between maintenance actions is needed in order to get a better grasp on the needs of the RF maintenance system. Such information is vital to providing our operators in a riverine environment the resources necessary to fulfill their mission successfully.

In the process of scoping and bounding the problem the RST identified several areas for future study of the FPS. The primary focus of this study was in the area of denying the threat a successful attack. The RST recommends that future studies examine the subsystems for predicting the threat and deterring the threat. The RST recognized that the alternative FPS architectures would have an impact in the area of deterrence, but did not focus modeling and analysis in this area.

The RST also recommends the long term effects of system suitability should be examined for the FPS architectures. The modeling conducted by the RST for the FPS architectures were all evaluated only at the actual time of attack in a certain operational area. It would be useful to know the performance of the architectures of the FPS's in different locations and over longer periods of time.

APPENDIX A: LIST OF REFERENCES

- Adams, Christopher M. "Inventory Optimization Techniques, System vs. Item Level Inventory Analysis." *Reliability and Maintainability 2004 Annual Symposium - RAMS* (2004). http://ieeexplore.ieee.org/xpls/abs_all.jsp?arnumber=1285423.
- American Technology Corporation. "LRAD 1000R: Remote Long Range Acoustic Device." <http://www.atcsd.com/site/content/view/27/41/>.
- American Technology Corporation. "LRAD: Long Range Acoustic Device." <http://www.atcsd.com/site/content/view/27/41/>.
- Armed Forces International. "PGMM – It's a hit!" <http://www.armedforces-int.com/categories/guided-mortar-munitions/pgmm-hit.asp>.
- Army.mil. "HMMWV." *U.S. Army Fact File*. http://www.army.mil/fact_files_site/hmmwv/index.html.
- Beaver, James W., and others. "Systems Analysis of Alternative Architectures for Riverine Warfare in 2010." MS diss., Naval Postgraduate School, 2006.
- Blanchard, Benjamin S., and Wolter J. Fabrycky. *Systems Engineering and Analysis*, 4th ed. Upper Saddle River, NJ: Pearson Education, 2006.
- Buede, Dennis M. *Engineering Design of Systems: Models and Methods*. New York: John Wiley & Sons, 2000.
- Buss, Arnold. "Basic Event Graph Modeling." Technical Notes from Simulation News Europe. 2001.
- Buss, Arnold. "Component-Based Simulation Modeling with SIMKIT." Proceedings from Winter Simulation Conference. 2002.
- Buss, Arnold H. "Component-Based Simulation Modeling." Proceedings from Winter Simulation Conference. 2000.
- Buss, Arnold H. "Modeling With Event Graph." Proceedings from Winter Simulation Conference. 1996.
- Buss, Arnold H. and Paul J. Sanchez. "Building Complex Models with LEGOS (Listener Event Graph Objects)." Proceedings from Winter Simulation Conference. 2002.
- Buss, Arnold H. and Paul J. Sanchez. "Simple Movement And Detection In Discrete Event Simulation." Proceedings from Winter Simulation Conference. 2005.

CDR David Schiffman. *OS4580 Logistics; Sustainability*. Naval Postgraduate School, 01 April 2007. Slides.

CDR Mike Doran. PCO LCS-1 Gold. *Littoral Combat Ship*. 2007. Slides.

Center for Naval Analyses. *Renewal of Navy's Riverine Capability: Resource Implications for Combat Support/Combat Service Support and TSC*, January 2006. Alexandria, VA: GPO, 2006.

Central Intelligence Agency. "Indonesia." *CIA – The World Factbook*.
<https://www.cia.gov/cia/publications/factbook/geos/id.html>.

Chief of Naval Operations remarks as delivered at the National Defense Industry Association Expeditionary Warfare Conference. Panama City, FL, 26 Oct. 2005.
<http://www.navy.mil/navydata/leadership/quotes.asp?q=11&c=6>.

Chief of Naval Operations remarks as delivered at the Naval War College. Newport, RI, 31 August 2005.
<http://www.navy.mil/navydata/leadership/quotes.asp?q=11&c=6>.

Chrzanowski, Krzysztof. *Non Contact Thermometry: Measurement Errors*. Warsaw, Poland: Polish Chapter of SPIE. 2001.

CMC (SCW) Robert Grenier. "CM Manning Point Paper." Working paper. U.S. Department of the Navy, 3 April 2007.

Cochran Steel. "Typical Razor Wire Fence Applications."
<http://www.cochransteel.com/typical.html>.

"Concept Paper on Global Fleet Stations." Working Paper, U.S. Department of the Navy, 25 January 2007.

Corpening, Michael, Linda Hurry, and Gregory Young. "The Role of Seabasing in SOF Operations." Report. Joint Forces Staff College, RI, 2006.

Cost and Economics Office of the Deputy Assistant Secretary of the Army. "CAIG Cost Element Structure." *OSMIS*. <https://www.osmisweb.com>.

Cotecmar. "Riverine Support Patrol Vessel." <http://www.cotecmar.com>.

Cutler, Thomas J. *Brown Water, Black Berets*. Annapolis, MD: Naval Institute Press, 1988.

CWO3 Rod Smith, "Riverine One Command Brief." 18th Navy Counselor Symposium, July 12, 2006. Slides.

Defense Acquisition University. "Joint Capabilities Integration and Development System"
http://akss.dau.mil/dag/DoD5000.asp?view=document&rf=GuideBook\IG_c1.3.asp.

Defense Logistics Agency. "Operational Rations." *Subsistence Homepage*.
<http://www.dscp.dla.mil/subs/rations/programs/index.asp>.

Defense Update. "Long Range Acoustic Device – LRAD." <http://www.defense-update.com/products/l/LRAD.htm>.

Devore, Jay L. *Probability and Statistics for Engineering and the Sciences*, 6th ed. Belmont, CA: Thomson Learning, 2004.

dtic.mil. "Army RDT&E Budget Item Justification (R2a Exhibit)."
<http://www.dtic.mil/descriptivesum/Y2008/Army/0604823A.pdf>.

"Dragon Fire I-II: Expeditionary Fire Support System." *Defense Update. Issue 1*, 2004.
<http://www.defense-update.com/products/d/dragon-fire.html>.

Eller, E.M. Introduction to *Riverine Warfare: The U.S. Navy's Operations on Inland Waters* by Department of the Navy – Naval Historical Center. Washington, DC: GPO, 2006. Also available online at
<http://www.history.navy.mil/library/online/riverine.htm#intro>.

Federation of American Scientists. "AN/SPS-67." <http://www.fas.org/man/dod-101/sys/ship/weaps/an-sps-67.htm>.

Federation of American Scientists. "CH-53 Sea Stallion." <http://www.fas.org/man/dod-101/sys/ac/h-53.htm>.

Federation of American Scientists. "Landing Craft Air Cushion (LCAC)."
<http://www.fas.org/man/dod-101/sys/ship/lcac.htm>.

Federation of American Scientists. "LHD-1 Wasp Class." <http://www.fas.org/man/dod-101/sys/ship/lhd-1.htm>.

Federation of American Scientists. "SH-60 LAMPS MK III Seahawk."
<http://www.fas.org/man/dod-101/sys/ac/sh-60.htm>.

- Federation of American Scientists. "Special Operation Forces Reference Manual (Version 2.1 Academic Year 99/00, Army Command and General Staff College.)" http://www.fas.org/irp/agency/dod/socom/sof-ref-2-1/SOFREF_Ch4.htm.
- Federation of American Scientists. "U.S. Land Warfare Systems." <http://www.fas.org/man/dod-101/sys/land/index.html>.
- Federation of American Scientists. "U.S. Navy Shipboard Combat Systems." <http://www.fas.org/man/dod-101/sys/ship/weaps/index.html>.
- Federation of American Scientists. "V-22 Osprey." <http://www.fas.org/man/dod-101/sys/ac/v-22.htm>.
- FLIR Systems. "SeaFLIR III." <http://www.flir.com/imaging/Maritime/Products/SeaFLIRIII.aspx>.
- FLIR Systems. "ThermoVision Sentry II." <http://www.flir.com/imaging/Security/Products/ThermoVisionSentryII.aspx>.
- Forsberg, Kevin, Hal Mooz, and Howard Cotterman, *Visualizing Project Management: Models and Frameworks for Mastering Complex Systems*, 3rd ed. Hoboken, NJ: John Wiley & Sons, 2005.
- General Dynamics. "U.S. Navy Type Classifies Mk49 MOD 0 Gun Weapon System." <http://www.gdatp.com/news/2005/NR-019.htm>.
- General Dynamics. "Operational Capabilities." *Littoral Combat Ship*. http://www.gdlcs.com/gd_opsCapability.html.
- General Jim McCarthy. *Transformation Study Press Briefing*. Press Briefing, 12 June 2001.
- Geocell Systems. "Rapid Deployment Fortification Wall (RDFW)." http://www.geocell-systems.com/brochures/pdfs/Modular_Versatile.pdf.
- Gibson James E., "How to Do Systems Analysis." Paper, University of Virginia: Charlottesville, Virginia, 1991.
- Global Security. "Classes and Subclasses of Supply." <http://www.globalsecurity.org/military/intro/supclass.htm>
- Global Security. "General Dynamics Littoral Combat Ship." <http://www.globalsecurity.org/military/systems/ship/lcs-pics-gd.htm>.

- Global Security. "High Speed Vessel."
<http://www.globalsecurity.org/military/systems/ship/hsv-gallery.htm>.
- Global Security. "Mechanized Landing Craft (LCM)."
<http://www.globalsecurity.org/military/systems/ship/lcm-gallery.htm>.
- Global Security. "M120 120 mm Mortar."
<http://www.globalsecurity.org/military/systems/ground/m120.htm>.
- Global Security. "Landing Craft Utility (LCU)."
<http://www.globalsecurity.org/military/systems/ship/lcu-gallery.htm>.
- General Dynamics. "Operational Capabilities." *Littoral Combat Ship*.
http://www.gdlcs.com/gd_opsCapability.html.
- Global Security. "Small Unit Riverine Craft (SURC)."
<http://www.globalsecurity.org/military/systems/ship/surc.htm>.
- Gourley, Scott R. "Lightweight Counter-Mortar Radar." *Army Magazine*. April 2002.
- Hardie, Ben. *Mini-Typhoon Remote Operated Small Arms Mount*. General Dynamics: Armament and Technical Products, April 27, 2005. Slides.
- Howstuffworks. "How LRAD Works."
<http://science.howstuffworks.com/lrad.htm/printable>.
- Jane's Radar and Electronic Warfare Systems. "AN/SPS-67(V) search radar."
http://www8.janes.com/Search/documentView.do?docId=/content1/janesdata/yb/jrew/jrew0382.htm@current&pageSelected=allJanes&keyword=SPS-67&backPath=http://search.janes.com/Search&Prod_Name=JREW&.
- Kauchak, Marty. "Building Forts." *Special Operations Technology*, November 19, 2006.
<http://www.special-operations-technology.com/article.cfm?DocID=1797>.
- Kollmorgen Electro-Optical. "Mk 46 Mod 1 Optical Sight System."
http://www.eo.kollmorgen.com/uploads/textWidget/wysiwyg/documents/AD-39_MK46_datasht.pdf.
- Kucera, Joshua. "Army calls for improved counter-mortar radar." *Jane's Defense Weekly*. 9 February 2006.
- Law, Averill M. and W. David Kelton. *Simulation Modeling and Analysis*. 3rd ed. Boston, McGraw Hill, 2000.

- Lawler, Clint, Greg Mitchell, and Il Suh, "Riverine Combat Support Ship (RCSS)." Report. Massachusetts Institute of Technology, MA, 2006.
- LCDR Frank Okata. "Riverine Support Unit." Working paper. U.S. Department of the Navy, 3 April 2007.
- Lockheed Martin. "Our Solution." *Littoral Combat Ship*.
<http://www.lmlcsteam.com/solution.html>.
- Marine Corps Warfighting Laboratory. "Dragon Fire II Experimental System NDIA Briefing."
http://www.dtic.mil/ndia/2004armaments/DayII/SessionII/07Lindsey_Dragon_Fire_II.pdf.
- Marine Corps Warfighting Laboratory. "Dragon Fire II Fact Sheet."
<http://www.mcwl.usmc.mil/factsheets/dragon%20fire%20II%205%20Aug%2005.pdf>.
- Mathworks, "MATLAB 7.4: Introduction and Key Features," *Mathworks*,
<http://www.mathworks.com/products/matlab/description1.html>.
- Mast, Karin. "Temporary Forward Operating Base Site Opens With Medical Task Force Training." *Triad Online*.
<http://www.mccoys.army.mil/readingroom/triad/04222005/TemporaryFOBase.htm>
- McLaurin, Mandy. "Navy Establishes First Riverine Group." *Navy newsstand*, May 26, 2006. http://www.navy.mil/search/display.asp?story_id=23854.
- Military.com. "A PAIR OF FOXES: The Navy's New RPV Lineup."
http://www.military.com/soldiertech/0,14632,Soldiertech_SeaFox,,00.html.
- Mobile Riverine Force Association. "Riverine Assault Force."
http://www.mrfa.org/riverine_assault.htm.
- Moniz, Dave. "5-foot-long plane to run recon missions for Marines." *USA Today*, 25 Mar 2004. http://www.usatoday.com/news/washington/2004-04-25-drone-usat_x.htm.
- Mulcahy, Paul. "LCU." *U.S. Watercraft*.
http://www.pmulcahy.com/watercraft/us_watercraft.htm.
- Naval Center for Cost Analysis. "ATMSR TMS Query." *Navy VAMOS*.
<http://www.navyvamosc.com/>.

- Naval Center for Cost Analysis. "Ship Class Average Query." *Navy VAMOS*.
<http://www.navyvamosc.com/>.
- Naval Expeditionary Combat Command. "About Us." <http://www.necc.navy.mil/>.
- Naval Expeditionary Combat Command. *U. S. Navy Riverine Group, Concept of Operation*. Little Creek, VA: GPO, 2006.
- Naval-Technology.com. "Cut Away View of an LPD-17." *LPD 17 (San Antonio Class) Landing Platform Dock, USA*. <http://www.naval-technology.com/projects/lpd17/lpd1710.html>.
- Naval-Technology.com. "Frank S. Besson Class LSV Logistic Support Vessel, USA." <http://www.naval-technology.com/projects/lsv/>.
- Naval-Technology. "Kollmorgen Electro-Optical Awarded \$13.75M Contract for MK46 Optical Sight Systems." http://www.naval-technology.com/contractors/weapon_control/kollmorgen/press4.html.
- Naval-Technology.com. "Vigilant Port Security Boat." <http://www.naval-technology.com/contractors/patrol/brunswick/brunswick2.html>.
- Navy Opportunity Forum. "Advanced Laser Target Designator/ Target Designator for the Mk 46 Optical Sight System (Mk 46 OSS)." <http://www.navyopportunityforum.com/abstracts.php?viewPageNum=3&query=&casesensitive=&matchword=>.
- Navy Times. "2007 Regular Military Compensation." *Navy Times*.
http://www.navytimes.com/static/money/pay_charts/2007regularmilitarycompensation/.
- Navy Times. "Navy Times Editorial: Clarity on Force Cuts." *Navy Times*.
http://www.navytimes.com/community/opinion/navy_opinion_editorial070219/ (accessed: April 2007).
- Navy Opportunity Forum. "Advanced Laser Target Designator/ Target Designator for the Mk 46 Optical Sight System (Mk 46 OSS)." <http://www.navyopportunityforum.com/abstracts.php?viewPageNum=3&query=&casesensitive=&matchword=>.
- Navy.mil. "High-Speed Vessel – HSV." *United States Navy Fact File*.
http://www.navy.mil/navydata/fact_display.asp?cid=4200&tid=1400&ct=4.
- Nussbaum, Daniel A. *OS3703 Systems Assessment Course Notes; Cost Estimation*. Naval Postgraduate School, 29 January 2007. Slides.

- Paulo, Eugene P. *SI4001 Systems Engineering and Architecture Course Notes; Needs Analysis*. Naval Postgraduate School, 10 July 2006. Slides.
- Pengelly, Rupert. "Militaries assess the long and short of weapon location." *Jane's International Defense Review*. 1 September 2004.
- Polmar, Norman *The Naval Institute Guide to the Ships and Aircraft of the U.S. Fleet*. 18th ed. Annapolis, MD: Naval Institute Press, 2005.
- Priolo, Gary P. "APL-39/APB-39/IX-502 Mercer." *NavSource Online*.
<http://www.navsource.org/archives/10/13/1339.htm>
- Priolo, Gary P. "LST-1192 Spartanburg County." *NavSource Online*.
<http://www.navsource.org/archives/10/16/161192.htm>.
- Priolo, Gary P. "LST-839 Iredell County." *NavSource Online*.
<http://www.navsource.org/archives/10/16/160839.htm>.
- Priolo, Gary P. "PC-1 Cyclone." *NavSource Online*.
<http://www.navsource.org/archives/12/0301.htm>.
- Priolo, Gary P. "Tank Landing Ship (LST) Index." *NavSource Online*.
<http://www.navsource.org/archives/10/16/16idx.htm>.
- Raytheon Corporation. "AN/SPS-67." <http://www.raytheon.com/newsroom/photogal/photos/sps67.jpg>.
- Raytheon Integrated Defense Systems. *Small Unit Riverine Craft (SURC) Reliability Summary 06-Q2*. Quarterly Report. August 2006.
- Ricci, Vic. *Spartan Scout ACTD USV Overview and Status*. Naval Undersea Warfare Center, March 10, 2006. Slides.
- Roman, Elmer L. "Trip Report for the Office of Naval Research Global – Latin America Office visit to the Columbian Navy R&D Institutions, 28-30 June 2006." Report presentation, Washington, DC, 28-30 June 2006.
- Sage, Andrew P., and James E. Armstrong Jr. *Introduction to Systems Engineering*. New York: John Wiley & Sons, 2000.
- SEACOR Marine. "Jim G." <http://www.seacormarine.com/ourfleet.cgi?type=ms>.
- SEACOR Marine "Sharon F." <http://www.seacormarine.com/ourfleet.cgi?type=crewfsv>.

- Sensor Fence, "Technology" <http://www.sensorfence.com/invention.html>.
- Singapore Technologies Engineering. "141m Landing Ship Tank." <http://www.stengg.com/CoyCapPro/detail.aspx?cylid=&pdid=104>.
- StrategyPage. "Counter-mortar Radar." *StrategyPage.com*.
<http://www.strategypage.com/htm/htart/articles/20040119.aspx>.
- Sovereign Publications Limited. "TERMA." <http://www.sovereign-publications.com/terma.htm>.
- Sun Tzu. *The Art of War*. Translated and edited by Ralph D. Sawyer. Boulder, CO, Westview Press, 1994.
- "SURC Failure Reporting Analysis and Corrective Action System (FRACAS) Information." *Raytheon Technical Services, Customer Logistics Support (CLS) Quarterly Report*, 26 March 2007.
- Tactical Water Purification System (TWPS)*. Knoxville, TN: Water Technologies, aqua-chem, Inc., [2004?].
- Temasek Defence Systems Institute. "Strategic Alliance." http://www.tdsi.nus.edu.sg/about_strategic_alliance.html.
- Terma Radar Systems. "Terma Radar Systems: Safety and Security in Ports and Inland Waterways." http://www.terma.com/multimedia/brochure_port4.pdf.
- United Nations. "Climate and Weather." *The Republic of Indonesia*.
<http://www.un.int/indonesia/Indonesia/Indonesia/indoninfo.html>.
- United Nations. "Land Geography." *The Republic of Indonesia*.
<http://www.un.int/indonesia/Indonesia/Indonesia/indoninfo.html>.
- United States Marine Corps, Small Craft Company, *Operation Phantom Fury (Al-Fajr) After Action Report*, 25 November, 2004.
- United States. Dept of Defense. Cost and Economics Office of the Deputy Assistant Secretary of the Army. *O&S Cost Web. O&S Cost for FY 2000-2006*.
<http://www.osmisweb.com>.
- U.S. Department of the Army. *Field Manual(FM) 5-114: Engineering Operations Short of War*. Washington, DC: GPO, 1992.
- U.S. Department of the Army. *Landing Craft. Utility (LCU 2000) Technical Manual (TM) 55-1905-223-10*. 17 January 1989. Washington, DC: GPO, 1989.

- U.S. Department of the Army. *Logistics Manual (ALM) 43-4302-C Overview of Army Maintenance Management*. Washington, DC: GPO, 2004.
- U.S. Department of the Army. *Technical Manual (TM) 5-698-2, Reliability-Centered Maintenance (RCM) for Command, Control, Communications, Computer, Intelligence, Surveillance and Reconnaissance (C4ISR) Facilities*, 2003. Washington, DC: GPO, 3 May 2003.
- U.S. Department of Defense. *Joint Publication 1-02: Department of Defense Dictionary of Military and Associated Terms*, 1 March 2007. Washington, D.C.: GPO, 12 April 2001.
- U.S. Department of Defense. *Joint Publication 3-0: Joint Operations*, 17 September 2006. Washington, D.C.: GPO, 2006.
- U.S. Department of Defense. *Joint Publication 3-02: Joint Doctrine for Amphibious Operation*, 19 September 2001. Washington, DC: GPO, 2001.
- U.S. Department of Defense. *Joint Publication 3-35: Joint Deployment and Redeployment Operations*, 7 September 1999. Washington, DC: GPO, 1999.
- U.S. Department of Defense. *Joint Publication 5-0: Joint Operation Planning*, 26 December 2006. Washington, DC: GPO, 2006.
- U.S. Department of the Navy. *Highlights of the Department of Navy FY2008 Budget*. Washington DC: GPO, 2007.
- U.S. Department of the Navy. *Marine Corp Reference Publication (MCRP) 4-11.8: Food Services Reference*. 10 September 1999. Washington, DC: GPO, 1999.
- U.S. Department of the Navy. *Marine Corps Reference Publication (MCRP) 3-31B: Amphibious Ships and Landing Craft Data Book*, 29 August 2001. Washington, DC: GPO, 2001.
- U.S. Department of the Navy. *Marine Corp Reference Publication (MCRP) 4-11A, Vol : Combat Service Support Field Reference Guide*. 12 June 2000. Washington, DC: GPO, 2000.
- U.S. Department of the Navy. *Marine Corps Warfighting Publication (MCWP) 4-11.4 Maintenance Operations*, 24 April 1998. Washington, DC: GPO, 1998.
- U.S. Department of the Navy. *NATOPS Flight Manual Navy Model MV-22B Tiltrotor*. 1 June 2000. Washington, DC: GPO, 2000.

- U.S. Department of the Navy. *Naval Doctrine Publication 4, Naval Logistics*, 10 January 1995. Washington, DC: GPO, 1995.
- U.S. Department of the Navy. *N87 Resource Officer's Guide for Conducting Risk Assessment*. 26 January 2007. Washington, DC: GPO, 2007.
- U.S. Department of the Navy. *Table of Allowances for Riverine Squadron One*. Washington, DC: GPO, [2007?].
- U.S. Department of the Navy. *U. S. Navy Riverine Group, Concept of Operations*, 18 May 2006. Little Creek, VA: GPO, 2006.
- U.S. Department of the Navy – Naval Historical Center. *Riverine Warfare: The U.S. Navy's Operations on Inland Waters*. Washington, DC: GPO, 1965. Also available online at <http://www.history.navy.mil/library/online/riverine.htm>.
- U.S. Naval Surface Warfare Center. *Riverine Assault Craft Replacement Craft Study*. West Bethesda, MD, 2000.
- U.S. Naval Surface Warfare Center, Dahlgren Division. *Operational Logistics: Navy Expeditionary Small Boat Units Draft*. Dahlgren, VA: GPO, 2007.
- U.S. Special Operations Command. *Operational Requirement Document (ORD) for the Special Operations Craft- Riverine (SOC-R)*, 5 January 1998. Washington, DC: GPO, 1998.
- USMC.mil. "Optics Systems: Target Acquisition System Device List." http://www.lejeune.usmc.mil/lmt/downloads/Target%20Acquisition%20Systems%20Devices%20_May%202006_.pdf.
- Wagner, Breanne. "Brown-Water Navy begins hunt for new riverine combat craft." *National Defense*. <http://www.nationaldefensemagazine.org/issues/2007/April/BrownWaterNavy.htm>.
- Walker, Ric. *US Coast Guard R&D System*. Underwater Port Security R&D, 16 November 2004. Slides.
- Wasil, Nigel. "Remote Operated Small Arms Mount (ROSAM)." www.dtic.mil/ndia/2004arms/session7/wasil.ppt.
- Wave Dispersion Technologies. "Maritime Homeland Defense and Force Protection Port Security Solutions: WhisprWave." <http://www.whisprwave.com/port.htm#scib>.

THIS PAGE INTENTIONALLY LEFT BLANK

APPENDIX B: TASKING LETTER FROM MEYER INSTITUTE



NAVAL
POSTGRADUATE
SCHOOL

Wayne E. Meyer Institute of Systems Engineering
Naval Postgraduate School
777 Dyer Rd., Monterey, CA 93943

6 December, 2006

MEMORANDUM FOR SEA-11 STUDENTS

Subj: SEA-11 CAPSTONE PROJECT OBJECTIVES

Enclosures: Tab A: Background for Capstone Project Development
Tab B: Preliminary Objectives for the Maritime Security Cooperation Project
Tab C: Preliminary Objectives for the Port Security/Force Protection Project

1. The objective of this memorandum is to provide guidance for the conduct of the integrated projects required for the completion of your degree. You will be required to complete your project by the first week of June, 2007, in accordance with the following plan and milestones.
 - (a) Develop a project proposal and a project management plan during the course of Prof Paulo's SI 3002 Project Management class. This proposal and plan will serve to focus your initial research and analysis. You should plan to review and update this plan frequently as you progress with your research.
 - (b) Conduct project reviews approximately every six weeks, finishing with a final brief to be scheduled for the first week of June, 2007.
 - (c) Begin outlining and preparing your Project Report as early as you can. Work with your faculty advisors, about every week, to prepare your Project Report for their approval and signature. The final report is due by 1 June, 2007.
2. Background information on the character and objectives of the projects is outlined in Tab A. The preliminary objectives statements for the two projects are contained in Tabs B and C. Your initial efforts should be to refine these objectives statements, based on research of current guidance documents and subject to the approval of your faculty advisors.

3. You will be expected to identify and integrate students and faculty from across the campus -- and other resources from outside the school -- to participate in your projects. This participation could include students who would join your groups, students doing related individual thesis topics, and faculty inside or outside NPS who have expertise related to your projects. It will be your responsibility to integrate the efforts of outside participants in your projects. Your faculty advisors will, of course, assist in these efforts.
4. Faculty advisors who have agreed to participate with SEA-11 include the following.
 - (a) Maritime Security Cooperation: Rear Admiral Paul Shebalin, USNR
 - (b) Port Security/Force Protection: Rear Admiral R. D. Williams, USN (ret)
 - (c) Management planning and systems engineering advisor: Dr. Gene Paulo
 - (d) Technology advisor: Prof Craig Smith.
5. The grades assigned to the participants in these projects will be pass/fail, and will be assigned by the lead faculty advisors of the individual groups. Although you will work as part of a team, your individual performance will be the basis for this evaluation. Successful completion and documentation of your project is a degree requirement.
6. I request each SEA-11 member acknowledge that you have read this letter by signing it and returning it to Dr. Paulo.

_____ Acknowledged

Dr. Frank Shoup
Director
Meyer Institute of Systems Engineering
Naval Postgraduate School
Monterey, California

Distribution:
SEA-11
RADM Shebalin, RADM Williams, Profs Hughes, Papoulias, Paulo, Smith,
Stevens, Solitario

Tab A

Background for Capstone Project Development

Objective

- Provide educational content appropriate to future professional careers as senior leaders.
- Apply course content to execution of projects.

Character of Capstone Projects

- Address future security environments.
- Relate strategic objectives, systems concepts, operational concepts, and technologies.
- Tailor topics to group size and composition.

Guidelines for SEA-11 Capstone Project Development

- New threats and missions
 - Joint missions: Joint, interagency, and international operational focus
 - Collaboration with NECC on emerging Navy missions
 - Collaboration with USCG and other interagency groups on interagency missions
- Interactions with wargaming, experimentation, and other related research efforts conducted at NPS and elsewhere
- Develop international student roles in integrated projects

Sources of guidance on current national maritime objectives

- NSPD-41/HSPD-11 “Maritime Security Policy”
- National Strategy for Maritime Security
- National Plans for Maritime Security

Related CNO guidance

- Navy Strategic Plan
- CNO Guidance for 2006
- Naval Operational Concept

Sources of guidance on future security environments, to include

- National Intelligence Council: “Mapping the Global Future” ...
- U.S. Coast Guard Project Evergreen

Tab B

Maritime Security Cooperation

Design a system of systems for performing selected missions associated with coalition operations in littoral and riverine environments.

Potential Focus Areas:

- Capability gaps and potential options for enabling future multi-national operations
- Joint, interagency, and intergovernmental command and control and information exchange
- CONOPS for joint, interagency, and international operations

Tab C

Port Security/Force Protection

Design a conceptual system of systems to improve Port Security measures for U.S. ports, and Force Protection options for U.S. forces in U.S. and foreign ports.

Potential Focus Areas:

- Develop a system of systems to provide individual ship self protection for U.S. Navy combatants
- Develop concepts and systems for the integration of U.S. Navy shipboard self protection systems with U.S. Navy shore based systems.
- Develop concepts and systems for U.S. commercial port security systems and the integration of U.S. Navy combatants and commercial vessels into these systems.

THIS PAGE INTENTIONALLY LEFT BLANK

APPENDIX C: ACRONYMS

APB	Self Propelled Barracks Ship
APL	Non-Self Propelled Barracks Craft
AO	Area of Operations
C2	Command and Control
C3	Command, Control, and Communications
C4ISR	Command, Control, Communications, Computers, Intelligence, Surveillance and Reconnaissance
CI	Configuration Item
CNO	Chief of Naval Operations
COASTS	Coalition Operating Area Surveillance and Targeting System
CONUS	Continental United States
CSSE	Combat Service Support Element
DES	Discrete Event Simulation
DOTMLPF	Doctrine, Organization, Training, Materiel, Leadership and Education, Personnel, Facilities
ECRC	Expeditionary Combat Readiness Center
ETC	Expeditionary Training Command
EOD	Explosive Ordnance Disposal
EMIO	Extended Maritime Interdiction Operations
FLS	Forward Logistics Site
FMC	Fully Mission Capable
FOB	Forward Operating Base
FP	Force Protection
FPS	Force Protection System
FY\$	Fiscal Year Dollars
GFS	Global Fleet Station
GWOT	Global War On Terrorism
HADR	Humanitarian Assistance/Disaster Relief
HMMWV	High Mobility Multi-purpose Wheeled Vehicle
HSV	High Speed Vessel
IA	Informations Assurance
IMA	Intermediate Maintenance Activity
IPT	Integrated Project Team
ITCZ	Inter-Tropical Convergence Zone
JFC	Joint Force Commander
JCS	Joint Chiefs of Staff
JFLCC	Joint Force Land Component Commander
JFMCC	Joint Force Maritime Component Commander
JOC	Joint Operational Center
KD	Kapal Di-Raja (Royal Ship, Malaysia)
KRI	Kapal Republik Indonesia (Republic of Indonesia Ship)
LCAC	Landing Craft Air Cushion
LCM	Landing Craft Mechanized
LCS	Littoral Combat Ship
LCU	Landing Craft Utility
LEGO	Listener Event Graph Objects
LST	Tank Landing Ship
LSV	Logistic Support Vessel
MADT	Mean Administrative Delay Time
MCAG	Maritime Civil Affairs Group
MCMT	Mean Time to Perform Corrective Maintenance

MCO	Major Combat Operations
MG	Machine Gun
MDS	Mobile Diving and Salvage
MIO	Maritime Interdiction Operations
MIT	Massachusetts Institute of Technology
MOB	Mobile Operating Base
MOVES	Modeling, Virtual Environments, and Simulation
MPMT	Mean Time to Perform Preventive Maintenance
MSC	Maritime Sealift Command
MSD	Mean Supply Delay Time
MSO	Maritime Security Operations
MTBMA	Mean Time Between Maintenance Actions
MTTR	Mean Time To Repair
MTVR	Medium Tactical Vehicle Replacements
NASA	National Aeronautics and Space Administration
NAVSCIATTS	Naval Small Craft Instruction and Technical Training School
NAVSEA	Naval Sea Systems Command
NCC	Navy Component Commander
NCW	Naval Coastal Warfare
NECC	Naval Expeditionary Combat Command
NMC	Non Mission Capable
NPS	Naval Postgraduate School
NUS	National University of Singapore
OR	Operations Research
OSMIS	Operating and Support Management Information System
PB	Light Patrol Boat
PCC	Pre-Combat Checks
PCI	Pre-Combat Inspections
PUK	Pack Up Kit
RAC	Riverine Assault Craft
RCSS	Riverine Combat Support Ship
RF	Riverine Force
RRC	Rigid Raiding Craft
RSS	Republic of Singapore Ship
RST	Riverine Sustainment Team
RS	Riverine Squadron
SEA	Systems Engineering and Analysis
SURC	Small Unit Riverine Craft
TDSI	Temasek Defence Systems Institute
TNT	Tactical Network Topography
TSC	Theater Security Cooperation
UAV	Unmanned Aerial Vehicle
U.S.	United States
VAMOSC	Visibility and Management of Operating and Support Costs
VTC	Video Tele-Conference

APPENDIX D: SURC FUEL CONSUMPTION AND ENGINE OPERATING HOUR CALCULATIONS

1. BACKGROUND

In order to determine the amount of fuel used by the SURC's during the MIO operation proposed in this scenario, several models were developed. A major assumption in this study is that the SURC's only refuel at their base of operation and there is no on station refueling. Fuel consumption rates were determined using the Fuel Consumption Graph (Figure D1) supplied by Yanmar Diesel, the manufacturer of the engines of the SURC.

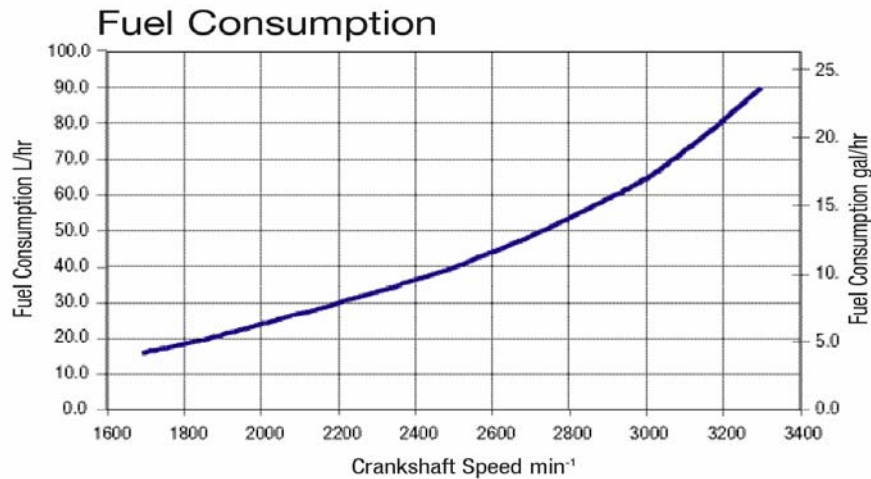

Figure D1: Fuel Consumption Graph for the Yanmar Diesel 6LY2A-STP⁴³²

Figure A depicts fuel consumption rates for a single Yanmar 6LY2A-STP engine. From this graph, typical fuel consumption rates for a two engine SURC operating at various speeds was derived and are shown in Table D1.

Speed (knots)	Fuel Consumption (gal/hr)
Idle	10
2	15
10	20
15	25
20	30
25	35
30	40
35	45
40	50

Table D1: SURC Fuel consumption at various speeds

A SURC mission profile was developed to determine the average amount of fuel consumed per craft during its on time station. It was determined from an EXTEND model that during a MIO mission, a SURC would consume 18 gallons per hour. With this data, a Monte Carlo Model was created in Excel to determine the total fuel consumed by these craft for an entire mission from the three basing alternatives.

2. SETUP

Table D2 below is the inputs into this Monte Carlo model for MIO missions performed from the three basing alternatives.

INPUTS	FOB	MOB	GFS	
Min Distance to MIO Area	1	1	40	nautical miles
Max Distance to MIO Area	15	25	54	nautical miles
Speed if AO<5nm	15	15	15	knots
Speed if AO>5nm	30	30	30	knots
Fuel Consumption Rate @ 15 knots	25	25	25	gallons/hr
Fuel Consumption Rate @ 30 knots	40	40	40	gallons/hr
Average Fuel Consumption Rate Performing Mission	18	18	18	gallons/hr
Time on Station Required	8	8	8	hours
Number of SURC's on Mission	4	4	4	craft
Number of Missions performed per week	34	31	21	missions
Pre-op boat checks/pre-watch brief/weapons issue	30	30	30	minutes
On-station setup/turnover	30	30	30	minutes
Post-watch debrief/weapon turn in/ post op boat checks	30	30	30	minutes

Table D2: Model Inputs

Input Explanations.

- **Minimum Distance:** The minimum distance was set at one nautical mile in accordance with the scenario guidelines for the FOB and the MOB. The minimum distance for the GFS was set at 40 nautical miles since the GFS would have to operate away from the mouth of the Kampar River in permissive waters.
- **Maximum Distance:** For the FOB, the maximum distance was determined to be 15 nautical miles with the assumption that the FOB was within the AO. For the MOB, the maximum distance was determined to be 25 nautical miles allowing the MOB operational flexibility to work and move outside the AO. For the GFS, the maximum distance was determined through iterations of the model with the assumption that a SURC must have a minimum of 10 gallons of fuel on return to the base following an operation.
- **Transit Speeds:** Taking operating procedures and human factors considerations into account, the speed for transiting was set at 15 knots if the AO was less than five nautical miles away and 30 knots if the AO was greater than five nautical miles away. Human factors considerations were that the faster these craft go and for longer durations at higher speeds, physical fatigue of the crewmembers becomes a concern. Transiting at high rate of speeds means that the crew can arrive on station faster, but their ability to perform the required eight hour mission might be diminished if they are physically fatigued.
- **Fuel Consumption Rates:** The transit fuel consumption rates average on station fuel consumption rates came from the previously discussed SURC mission profile and Table II.
- **Mission Profile:** From the scenario, in order to ensure 24 hour a day/7 days a week coverage, it was determined that time on station would be eight hours and that 1 detachment of four SURC's was required for each mission. Given 24 hours a day and operating in eight hour, non-overlapping shifts equated to a minimum 21 missions per week. The pre-operation boat checks, on station

time, and post watch debrief times were estimated at 30 minutes apiece in order to calculate the entire duration of the mission for the crew and engine run hours.

3. RESULTS

From these inputs, Monte Carlo Model was constructed for 500 iterations and various data was extracted. A summary of this data is displayed in Table D3.

		FOB	MOB	GFS	
Round Trip Transit Data per SURC	Average Round Trip Transit Time	35.66	54.73	189.04	minutes
		0.59	0.91	3.15	hours
	Average Round Trip Fuel Consumed	22.15	35.49	126.03	gallons/round trip
	Average Fuel Left to perform Mission	277.85	264.51	173.97	gallons
<hr/>					
Patrol Data	Average Fuel Used On Station	144.00	144.00	144.00	gallons/patrol
<hr/>					
Total Mission Data	Average Fuel Used per Mission	166.15	179.49	270.03	gallons/mission
	Average Fuel Remaining after Upon Return to Base	133.85	120.51	29.97	gallons
	Minimum Fuel Remaining Upon Return to Base	116.11	89.40	12.05	gallons
	Maximum Fuel Remaining Upon Return to Base	152.51	152.46	49.30	gallons
<hr/>					
Detachment Data	Average Round Trip Fuel Consumed	88.59	141.96	504.10	gallons/det round trip transit
	Average Fuel Used On Station	576.00	576.00	576.00	gallons/patrol
	Average Fuel Used per Mission	664.59	717.96	1080.10	gallons/mission
	Total Fuel Consumed Per Week	13956.39	15077.16	22682.12	gallons
<hr/>					
	Total Mission Time	10.08	10.43	12.66	Hours
	SURC Operating hours/day	8.61	8.88	11.13	hours/day
	SURC Operating hours/week	60.27	62.16	77.89	hours/week

Table D3: Excel Monte Carlo MIO Results

From the above data, there is nothing surprising about the results. Common sense would dictate that the further away a vessel operates from the base of operation and the longer the missions are the more fuel will be consumed. However, one significant item to point out from these initial runs was that in order to meet the assumption that a SURC

must have a minimum of 10 gallons of fuel upon return to base; the GFS could only operate a maximum of 54 nautical miles away from the AO, the boat crews had to be very fuel conscience (which could impact their operational abilities), and that the time on station could be no greater than eight hours. This greatly limits the operational flexibility and maneuverability of the riverine forces on mission and the GFS basing alternative in this scenario.

Next, various aspects of this model were examined. If the total fuel consumed per week was equivalent among all three basing alternatives the number of missions per week for the various basing alternatives was determined. Essentially by keeping the GFS profile constant since it is the limiting factor, it was determined that 34 operations per week could be performed from a FOB and 31 missions per week could be performed from a MOB. A typical fuel curve for the basing alternatives is shown below in Figure D2. This increase of 10 to 13 extra missions a week would allow commanders more operational flexibility and supplement missions with extra craft as necessary.

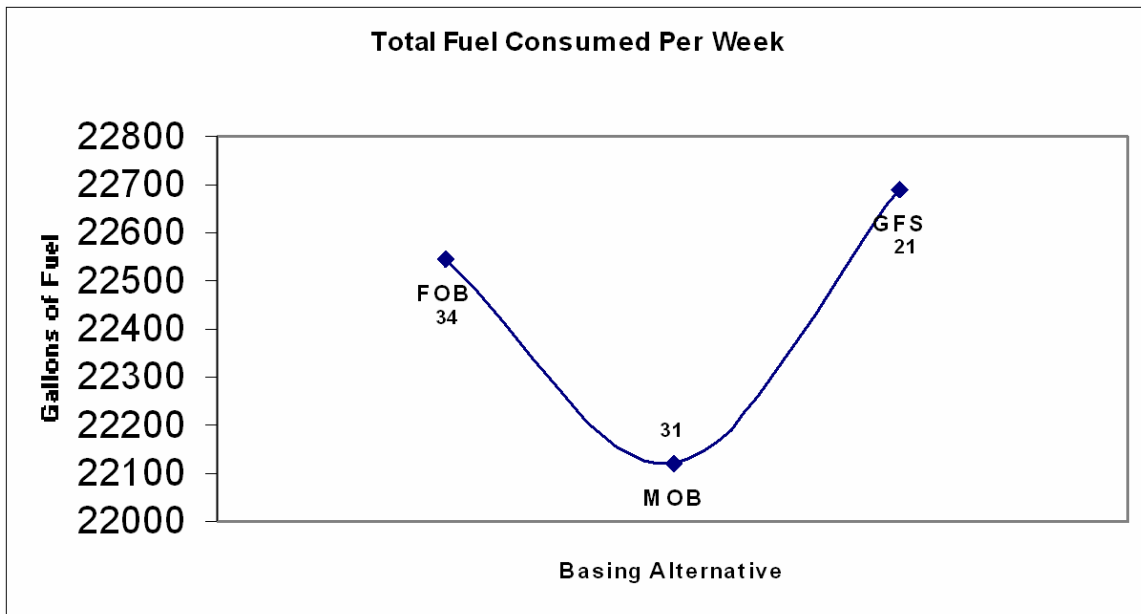

Figure D2: Total Mission Fuel per Week versus Number of Missions and Basing Alternative

In Conclusion, from this Excel model, the fuel consumption rates for performing this operation and engine run time data were incorporated throughout the technical report. Some interesting observations were also taken away from this analysis. Numerous more missions could be performed from a FOB or MOB in this scenario. As stated previously, operations from a GFS basing alternative would restrict RF operations. This topic of how to extend the range of riverine forces up river while operating from a GFS was not discussed in this paper but needs to be addressed.

⁴³² Yanmar “LYA Series Marine Diesel Engine (370-440hp),” *Yanmar Marine*, http://www.yanmar.com.au/marine/lya_series/lyaseries.htm.

APPENDIX E: A STUDY INTO THE POTENTIAL FOR WIRELESS TECHNOLOGIES AS AN ALTERNATIVE COMMUNICATIONS ARCHITECTURE FOR RIVERINE FORCES.

1. INTRODUCTION

1.1 Discussion of Military Communications

Admiral Alfred Thayer Mahan wrote at the turn of the century, “Communications dominate war...they are the most important single element in strategy.” More to-the-point, General Mark Clark remarked during World War II that without communications, all he could command was his desk.⁴³³ Communication in a tactical military environment is difficult due to its dynamic nature, changing environment and lack of fixed infrastructure in terms of wired connections. Due to these challenges, the military employs various devices that transmit and receive information utilizing the radio frequency (RF) spectrum. By using RF, a military communications device is able to move freely about the battlefield without hindrance of being hardwired to any fixed point. Consequently, the military is able to freely extend the distance between devices without the need for (or extra cost of) running wires throughout the tactical environment.

For decades, the military has used radio devices to transmit and receive information that primarily consisted of voice data in an analog format. This method provided a much needed conduit to transmit and receive information, but this information was limited. These connections were limited to single channel radio and circuit switched phone networks. Now, with the emergence of the concept of Network Centric Warfare and the widespread use of the Internet, there is a need for these military radio devices to transmit and receive digital data that may consist of text, video, voice and imagery to multiple users that are dispersed throughout a tactical environment.

Small boats, which are the primary operators in Maritime Interdiction Operations (MIO) and riverine operations, do not have the multiple communications capabilities which have been developing along the NCW transformation in larger vessels. Much like the individual foot soldier, logistics and power considerations have historically prevented

the link of communications to these operators. The technological revolution is changing this link to the disadvantaged user. Unlike the foot soldier, the small boat has electrical power, similar to land based vehicles, and therefore can be empowered as a communications relay more easily than a foot soldier. This enables more connectivity to the small boat operator, who like the foot soldier, relies on battery power for communications links.

One could argue that the US does not need to add newer platforms or weapons systems, but instead to improve its command and control interoperability, not only within the fleet, but also with coalition Naval and Coast Guard Forces around the globe. The guiding principle of interoperability sums this situation up with the need for an unprecedented level of information sharing required by all participants. Riverine environments are all significantly different and robust communications capabilities will be required to compensate for these differences. One of the key obstacles to overcome this is the communications interoperability with indigenous, paramilitary and military forces, which must be connected with US riverine operators. To link all units of a force, radio transmissions must be capable of being transmitted and received by all participants. This is easier done where identical equipment is outfitted among the different units, but this is often not feasible due to the economic costs and proprietary engineering found on modern tactical radios. The difficulty of integrating the communications of more than one military service has been a challenge faced by military forces for some time. With the addition of law enforcement forces, various government agencies, and humanitarian response groups, this problem increases in unprecedented complexity. This is especially true today, when current naval communications are inadequate to maintain the modern national fleet (combined US Navy and US Coast Guard) with its overwhelming GWOT mission requirements.

The current concept of operations (CONOPS) implemented by the U.S. Navy Riverine Force was based strongly on the equipment and procedures used by the United States Marine Corps (USMC), which until February of 2007, held the primary charter for conducting operations in a riverine environment. The USMC riverine doctrine utilizes the concept of distributed operations, which is defined by the Marine Corps Warfighting

Lab (MCWL) as “...an operating approach that seeks to create an advantage over an adversary – spatial, temporal and psychological – through the intentional use of dispersion and independent small-unit tactical actions, which are enabled by increased access to functional support.”⁴³⁴ This concept of distributed operations as applied to a riverine force requires, “a reliable, secure, rapid communication system.”⁴³⁵

To address these issues, the US military is developing a working communications architecture based around the Joint Tactical Radio System (JTRS). JTRS is the Department of Defense (DoD) attempt to develop software defined ground, airborne, and maritime tactical radios that are capable of transmitting multiple waveforms within each radio. It is intended that once this system is fully fielded within the military, it will reduce the number of radios needed by the military, to 250,000 radios (vice the currently fielded 750,000 legacy radios) by combining communications functions and using common components.⁴³⁶ This will cost the DoD an estimated \$40 billion to replace every currently fielded legacy radio with a JTRS. A Government Accounting Office (GAO) report of the status and outlook of JTRS states the following:

“The program still faces several managerial and technological challenges that could affect the DoD’s ability to develop and procure JTRS radios successfully. These include managing requirements and funding, maturing key technologies, integrating system components, testing, and developing secure communication. The most significant challenge we identified is the lack of a strong, joint management structure.”⁴³⁷

The operational requirements placed on the riverine forces and their coalition partners will call for a reliable, robust, secure and manageable network topology architecture to be able to deliver the full scope of their intended communications, and any shortfalls will need to be compensated for. There are numerous benefits to be gained in leveraging commercial, off the shelf (COTS) technologies, while implementing the features that will be unique to the riverine combat environment.

1.2 The Systems Engineering Design Process (SEDP)

The SEDP was used to guide and facilitate the work done throughout the development and analysis in this project. An iterative process, the SEDP allowed for constructive generation and organization of ideas based on continuous feedback. Progression through the SEDP occurs in four distinct phases: Problem Definition, Design and Analysis, Decision Making, and Implementation. The relationship among the phases is shown in the flow diagram of the SEDP (Figure E1).

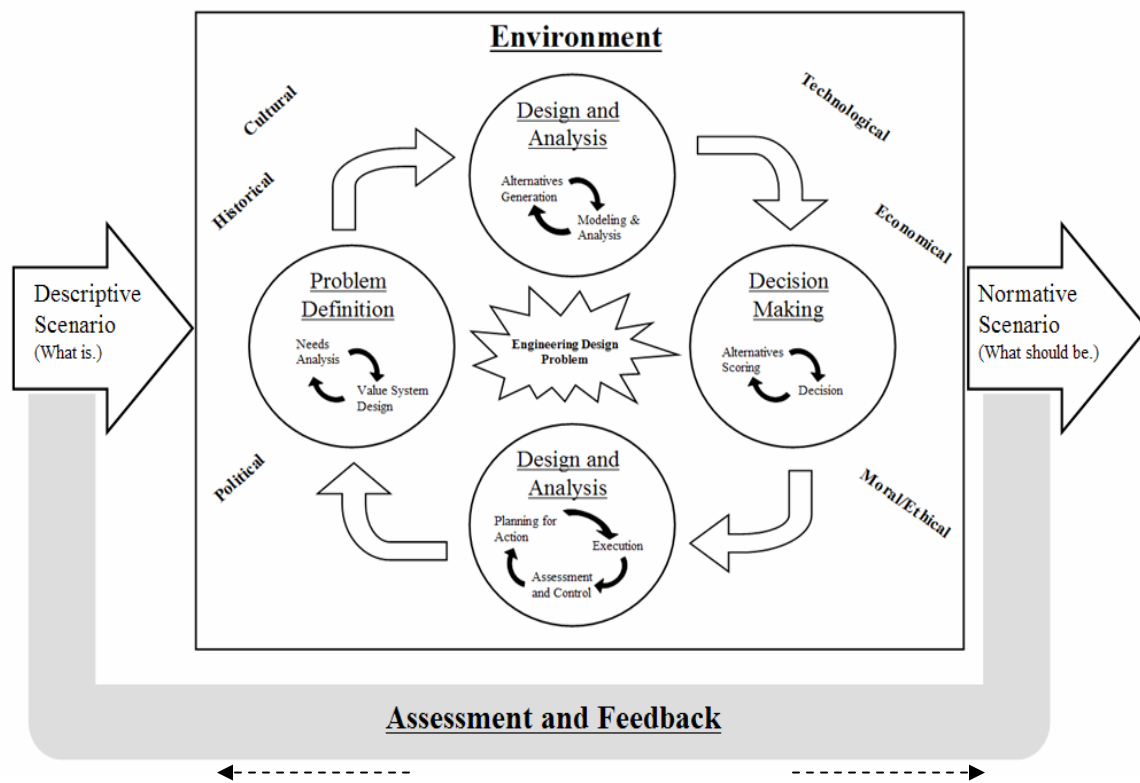

Figure E1 The Systems Engineering Design Process Flow

Supporting each phase was a unique subset of steps that focused on achieving the goals of the individual phase. Similar to the iterative relationship between the phases, the subsets of tasks were also cyclic. The iterative steps contained within the iterative phases allowed for constant refinement and improvement during the process. The goal of the

Problem Definition phase is to unambiguously define the challenge at hand. Needs Analysis and Value System Design are the main steps in this phase. The Needs Analysis step attempts to identify system requirements by involving system decomposition, stakeholder analysis, functional analysis and futures analysis. The Value System Design step attempts to arrange and rank the system requirements through the creation of a value hierarchy followed by the determination and weighting of measures of evaluation.

The goal of the Design and Analysis phase is to generate and examine potential solutions to the problem. Alternative Generation and Modeling and Analysis are the steps in this phase. The Alternative Generation step used structured brainstorming to develop potential solutions to the problem. The Modeling and Analysis step seeks to compare alternatives by using technical performance models, agent-based models, and/or statistical analysis and modeling tools in an integrated overall modeling plan.

The goal of the Decision Making phase is to compare the modeling results for alternatives and recommend the best course of action. The SEDP was only completed through the Alternative Scoring step for this study, since a decision recommendation was the desired final outcome. Therefore, the Decision step was not accomplished. Alternative Scoring ranked the alternatives based on four factors: security, transmission capability, receive capability, and interoperability.

The goal of the Implementation phase would have been to execute the selected solution, monitor its progress, and solve the determined problem. This phase in the SEDP was beyond the scope of this analysis and, therefore, was not performed.

Throughout the application of the SEDP, changes and adjustments were made, and past work was revisited and revised as new information and insights became available. This constant modification resulted from the continual feedback inherent in the SEDP, and led to a more robust solution than would be available with a one-time-through approach. Thus, the SEDP served as an extremely useful framework to organize and structure the work that was done in this study.

2. PROBLEM DEFINITION

Needs Analysis was the first step in the Problem Definition phase of the Systems Engineering Design Process. The primary purpose of Needs Analysis is to develop a Revised Problem Statement, or Effective Need Statement, that reflects critical stakeholder concerns. It provided justification for proceeding further and expending time, effort, and other resources in the design process. The resulting Effective Need Statement is the cornerstone on which the entire subsequent design and decision process is built.

2.1 Needs Analysis

Initially, there was not much concern, on the part of the stakeholders, with the configuration and use of the current communications suite fielded on the Small Unit Riverine Craft (SURC) that were to be used by the riverine forces. This resulted in the derivation of an initial Primitive Need Statement, from interviews with potential stakeholders, to “Design a conceptual system of systems to allow reliable, secure, multifaceted communications for riverine forces to use while conducting MIO operations.” The intent was to design and assess integrated alternative architectures for a riverine force and coalition partner, focusing on a MIO scenario taking place in the Kampar River, in Thailand, supported from a forward operating base (FOB) in the area of operations. The group conducted Needs Analysis by utilizing a variety of tools including System Decomposition, Stakeholder Analysis, Input/Output Model, and Functional Analysis to determine an Effective Need Statement from the initial Primitive Need Statement.

2.2 System Decomposition

System Decomposition enabled the group to identify a hierarchical structure and the major functions and components of a communications system, and is illustrated in Figure E2. The primary functions of communications that were identified were to

receive, analyze, store, secure, interoperate and finally disseminate (transmit) information.

The three levels of the hierarchical structure were super, lateral, and subsystems. The super systems relative to the communications system were the Joint Forces Maritime Command Component (JFMCC), US Naval Expeditionary Combat Command (NECC), and the US Riverine Forces. Lateral systems included supply and logistics elements, repair and maintenance elements and force protection elements. Communications subsystems included the personnel that would eventually be the end-user of the system and its associated equipment.

The system included structural, operating, and flow components. The structural components consisted of the laptop computers, transceivers and associated antenna. Operating components included the necessary operating software and encryption algorithms. Flow components were the information types that could utilize the system, specifically in the form of voice, data, video or imagery.

Possible operational states that the system could exist in were identified as being powered on and fully functional, powered off, or powered on yet not operating to necessary operational minimums in at least one design parameter.

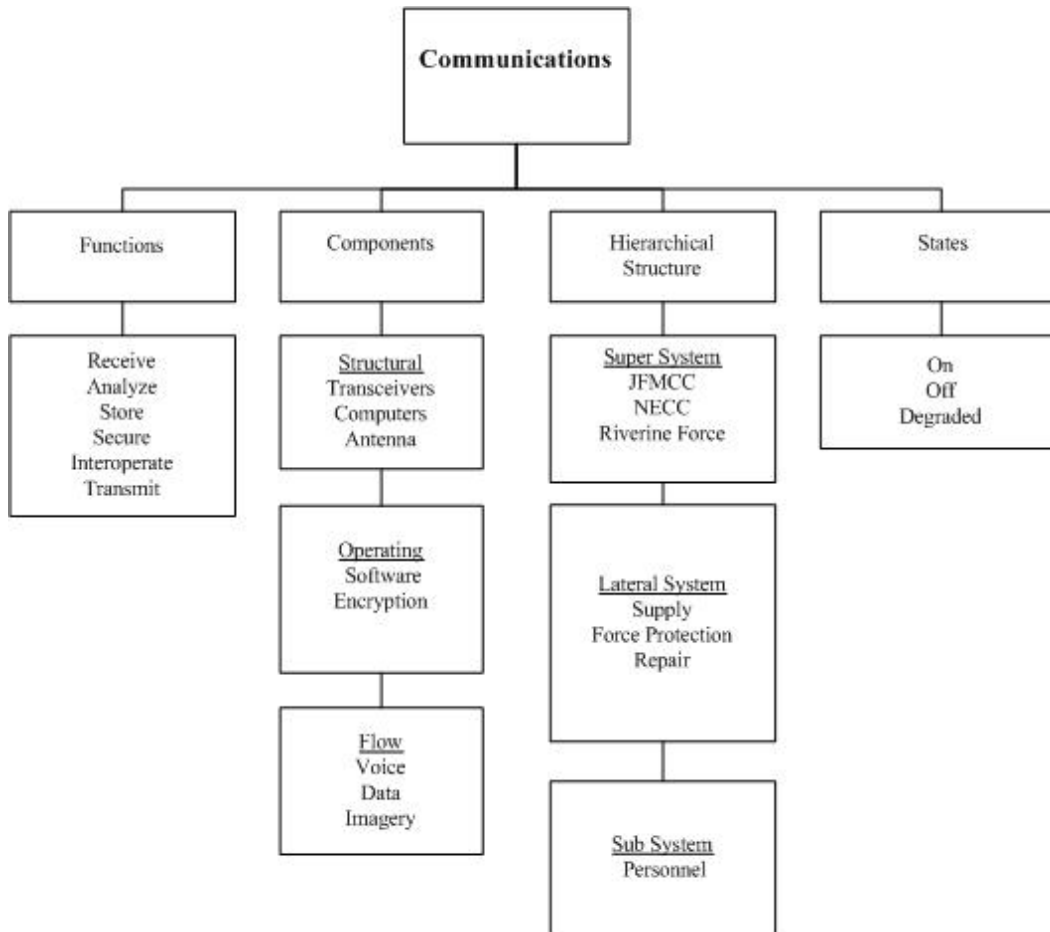

Figure E2 Communications System Decomposition

2.3 Stakeholder Analysis

Stakeholder Analysis began with the identification of critical assumptions and constraints on the problem. These assumptions and constraints set the boundary conditions for the problem and framed the range of problem solutions. These boundaries came from variety of sources and included assumptions ranging from strategic to tactical. In many cases, there was insufficient stakeholder access, resulting in additional consultation with subject matter experts from the Naval Postgraduate School faculty and student body. Stakeholder Analysis was conducted primarily through research and interviews with current and potential stakeholders. The need for secure, reliable communication of information was a common need, want, or desire of each stakeholder.

An interview with a United States Navy (USN) communications officer, who has technical familiarity and operational employment expertise with current systems, was able to provide insights into the operational issues of actual implementation.⁴³⁸ He also identified limitations of current capabilities such as single channel operations and insufficient bandwidth for the amount of information needing to be passed through the system. These current issues and limitations provided a basis for determining what a communications system *should* do (i.e., its functions).

2.4 Input-Output Model

A basic system Input-Output Model was designed utilizing the information gained from the Stakeholder Analysis, in order to visualize the necessary communications architecture as a system with Inputs and Outputs. The Input-Output Model developed (Figure E3) shows the Controllable and Uncontrollable Inputs and the resulting Intended Outputs and Unintended By-Products.

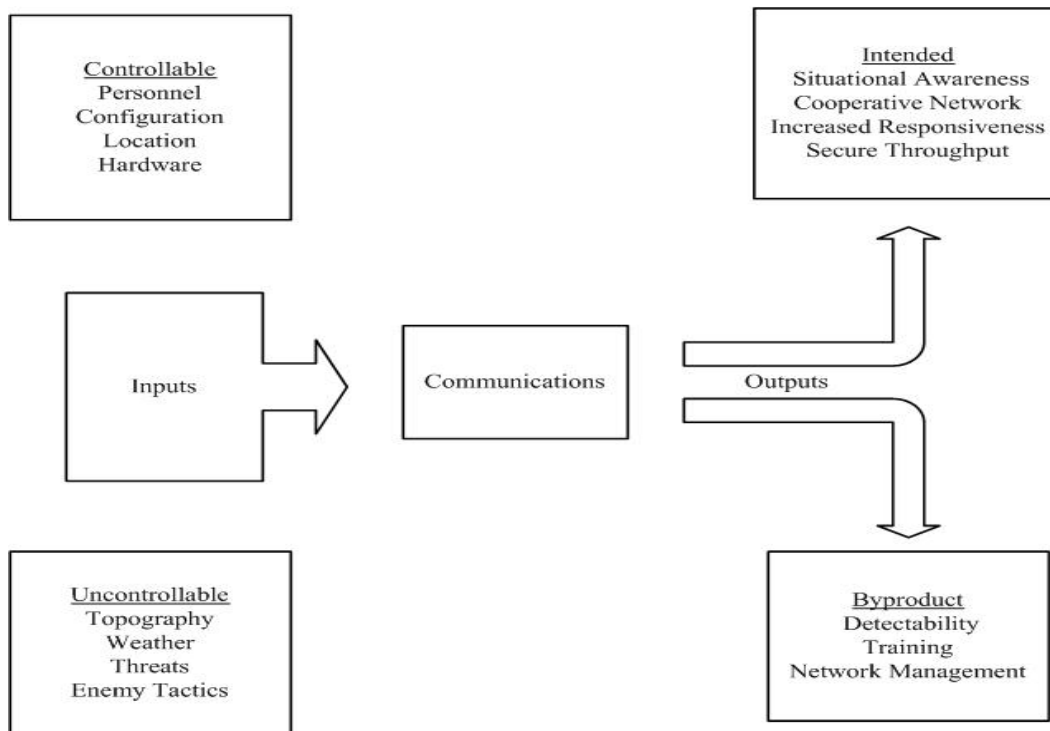

Figure E3 Communications System Input-Output Model

The Input-Output Model separated the communications system from its surroundings, giving a different perspective of the system. This was useful for determining which parameters could be used to influence the system outcome, and which system outcomes were undesirable. System design and performance would be affected by both Controllable and Uncontrollable Inputs.

The Controllable Inputs to the communications system were determined to be personnel who would utilize the system, equipment configuration and setup, geographic location of system employment and the individual system hardware components. Three types of Uncontrollable Inputs were identified: *unknown* such as threat events or enemy tactics; *estimable* such as location topography; and *random* such as weather.

The primary Intended Output of the system was to create a high level of situational awareness and response capability that would allow command and control decisions to be made and acted on more rapidly. This intended output would be scalable to account for inclusion of coalition partners in utilization of the system. Unintended By-Products included detectability of system transmissions, additional training of personnel to utilize the system and possible need to a dedicated network manager.

2.5 Functional Analysis

The Functional Analysis step of the Problem Definition phase determined what the system should do to meet the stakeholders' needs, wants, and desires. It provided a system overview of the process being designed. From this overview, objectives and metrics could be linked to functional areas in order to develop a value systems design for the system. What needed to be accomplished was identified, a hierarchy of these needs was established, and resources and components were then identified.

The system had to receive incoming transmissions of information, analyze what was received, organize the information, possibly store the information for later use (for

items such as imagery or video), ensure it was secure from compromise, and then transmit any information output for use by both coalition partners and own forces.

The Receive function would allow transmissions of information from external sources to be brought into the system. Once received, the information would undergo the Analyze function in order to determine transmission format (either analog or digital) and whether the information carried is encrypted. The system may then execute the sub-functions of *converting* the received transmission to the necessary format needed in the remainder of the system, and *decryption* of the information for ready use. Once decrypted and in the system, the information would undergo the organize sub-function and be arranged according to type (voice, video, imagery, etc). This arranged information would then allow for the Store function to be performed for information such as video and imagery that may be needed at a later time. The Secure function would take necessary actions to ensure that information in the system would not be compromised. This would be done in a layered approach, utilizing supporting sub-functions of *monitoring* of the network for unintended activity, *authentication* of users of the system to ensure only authorized personnel would be allowed access in, and *encryption* of the information itself. Information within the system would now be available for the Transmit function and be disseminated externally from the system to other units. The availability of this information facilitates the final function of the system, which is the ability to Interoperate with other communications systems.

Each of these functions and associated sub-functions were determined by asking the question, “What does the system component do?,” while ignoring “how” the system would perform the function. A Functional Flow Diagram (Figure E4) was developed as part of Functional Analysis in order to delineate the logical functional process of what the system would do and gave a chronological view of the way top-level functions related to each other. This perspective was useful for determining how the outputs from some functions served as inputs to other functions.

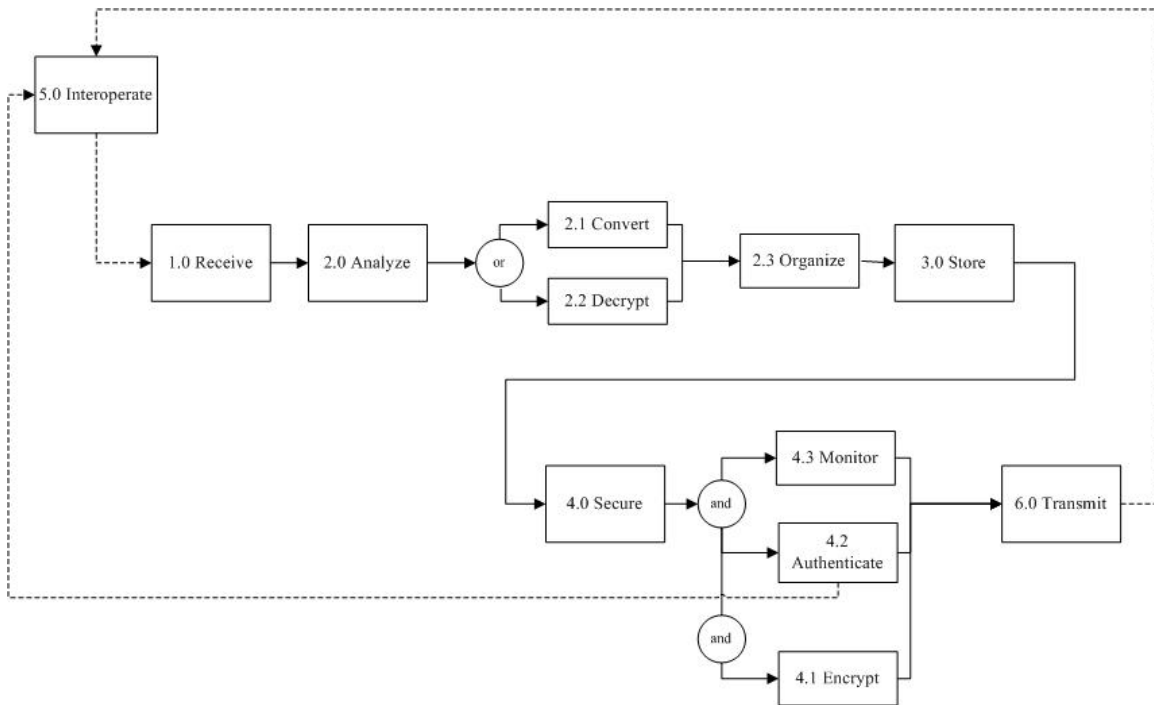

Figure E4 Communications System Functional Flow

Stepping through the Functional Flow Diagram provided a picture of how the system would work.

The Functional Flow Diagram was used as an aid in the creation of the Functional Hierarchy (Figure E5). The Functional Hierarchy delineated “what” the system did according to its top-level primary functions and any associated sub-functions that would be needed in support of a top-level function.

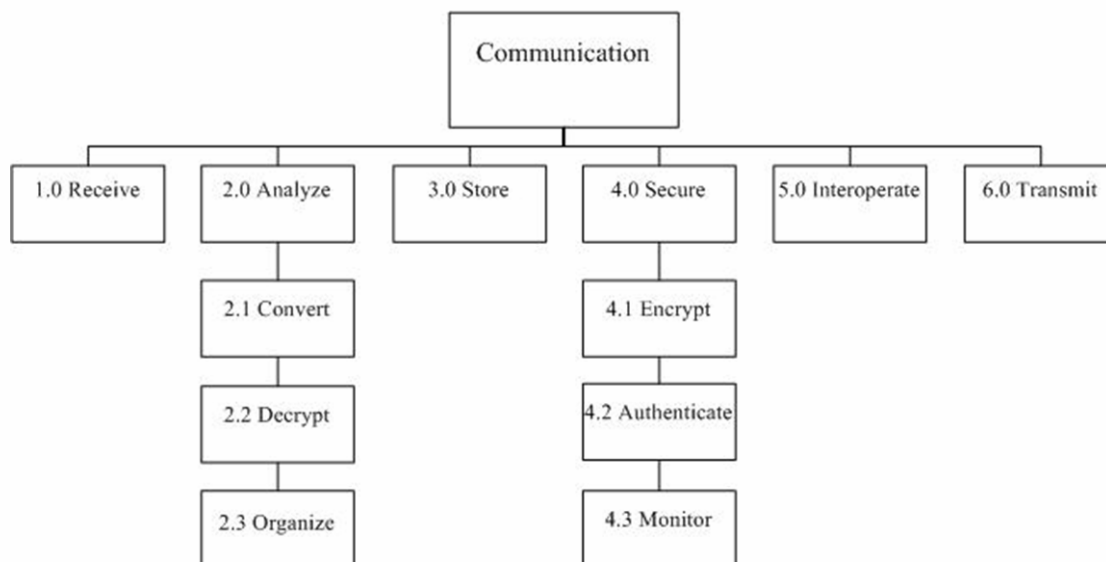

Figure E5 Communications Functional Hierarchy

It also gives a snapshot of “how” the system accomplished each top-level function. For example, Secure was accomplished by use of encryption, authentication and monitoring.

The Communications architecture was required to be capable of transmitting and receiving multimodally, with the capability to process voice, video, data and image exchanges. In addition to transmitting and receiving relevant data, the communications architecture needed to analyze information—converting it and organizing it to make it usable and manageable through the system and for users. In addition, data type would need interpretation at various points to ensure proper display and relevance. The communications network would not be effective unless relayed information could be readily understood such that individual action elements, regardless of nationality, had a clear operational picture and the same understanding of C2 decisions that determined actions. Another consideration arising from the design of architectures for use within a multinational force structure was the difference among the nations in technology development and existing commercially and militarily available technologies. Because

of these inherent differences, information organizing and processing could differ from nation to nation, possibly requiring data conditioning between communications points or platforms. Security was a consistent concern in multinational operations and it necessitated encryption and decryption capability at transmission and reception points. The Communications architecture could network a variety of equipment, platforms, and other applicable technologies and would therefore need to be capable of scaling in size to accommodate new users as they enter or leave the network.

2.6 Effective Need Statement

The product of the Needs Analysis step is a revised problem statement, called the Effective Need Statement, reflecting the most significant needs and desires of the stakeholder. After iterative analysis of all components and tasks in the Needs Analysis step, the Effective Need Statement evolved to read: “Design a conceptual secure, adaptable architecture that will allow utilization of multiple information types with a greater capacity of throughput than the currently used system.”

2.7 Objectives Hierarchy

The Objectives Hierarchy provided detailed analysis of the functions the system must perform and the objectives the system must satisfy. The Objectives Hierarchy delineated the different system functions, which it further broke down into sub-functions, objectives, and evaluation measures. The end product of the Objectives Hierarchy was a representation of the system breakdown, from top-level functions and objectives down to the evaluation measures that would determine system performance. The metrics developed in the Objectives Hierarchy would be used to help generate system requirements.

The objectives and MOE’s for Communications were developed as an integrated effort between SEA-11 and the Temasek Defense Systems Institute (TDSI) Communications and Information Assurance (IA) tracks. The professional expertise the

TDSI students brought into the process assisted greatly in the development of an effective Objectives Hierarchy that included functions applicable to the IA domain. Communications MOE's are given in Table E1.

<u>Functions</u>	<u>Objectives</u>	<u>MOEs</u>
Receive	<ul style="list-style-type: none"> - Maximize successful and correct reception of data - Minimize transmission loss - Minimize need for re-transmission 	<ul style="list-style-type: none"> - The system has the capability to receive - Call completion rate - Percentage of dropped calls - Error correction and recovery capability
Analyze	<ul style="list-style-type: none"> - Convert data to digital format - Maximize correct decryption - Determine data type 	<ul style="list-style-type: none"> - Amount of time required to decrypt data for use - Probability of failure of decryption
Store	<ul style="list-style-type: none"> - Store data for later retrieval or re-transmission 	<ul style="list-style-type: none"> - Data download rate - Time to achieve maximum storage capacity per data type - Durability of storage media - Reliability of storage media
Secure	<ul style="list-style-type: none"> - Prevent unauthorized disclosure of data - Maximize security of transmissions between units - Maximize encryption of data - Grant right/privileges to users, controlling access - Enforce authenticity of users 	<ul style="list-style-type: none"> - Probability of data exploitation due to encryption failure - Percentage of intrusion attempts detected - Susceptibility of system integrity to compromise
Interoperate	<ul style="list-style-type: none"> - Minimize network downtime - Successfully integrate additional, authorized users - Maximize robustness and redundant capability 	<ul style="list-style-type: none"> - Scalability of network nodes (number in use per area) - Average downtime per node
Transmit	<ul style="list-style-type: none"> - Maximize successful and correct transmission of data - Minimize transmission loss - Minimize need for re-transmission 	<ul style="list-style-type: none"> - The system has the capability to transmit - Data throughput (bit per second)

Table E1 Communications Objectives Hierarchy

2.8 Requirements Generation

Alternatives Generation for Communications and IA was primarily conducted by the TDSI Communications and IA tracks. Requirements were derived from the scenario description, available CONOPS, Effective Need Statement, and the Objectives Hierarchy. The requirements to securely, reliably transmit and receive transmissions among units and be flexible enough to scale in size according to addition and subtraction of users (including coalition partners) were common items of concern expressed by all stakeholders surveyed. A listing of all requirements provided by stakeholders is given in Table E2.

<p>Communications Requirements:</p>	<ul style="list-style-type: none"> ▪ Twenty-four hours a day/seven days a week availability ▪ Accommodate mobile nodes ▪ Interoperable with other systems ▪ Point-to-Point and Point-to-Multipoint broadcast. ▪ Time latency (near real time) ▪ Digital
<p>Information Assurance Requirements:</p>	<ul style="list-style-type: none"> ▪ Secure transmissions ▪ Control of accessibility. ▪ Information integrity ▪ Availability of information

Table E2. Stakeholder Specified, System Requirements

2.9 Communications System Requirements

The system needed by the stakeholders would have several specific requirements that would need to be satisfied in terms of its functionality as a communications system and its ability to move information securely.

When needed for operations, the system would need to transmit information with a minimal amount of delay between transmission and complete receipt of usable

information. The communications system would have to be available for use around the clock, for as long as an operation is being conducted, with minimal interruption or downtime. During this time, it would also have to be able to accommodate multiple, mobile users (nodes) entering and leaving the area of operations (AO). It should be able to transmit between units in multiple modes of operation. Specifically, Point-to-Point transmission for directed communication to a specific unit, or Point-to-Multipoint transmission for broadcast of transmissions to multiple units simultaneously. The system would have to allow for the interoperability of nodes with minimal complications involving system configuration or set-up. Interoperability is defined as the condition achieved among communications-electronics systems or items of communications-electronics equipment when information or services can be exchanged directly and satisfactorily between them and/or their users.⁴³⁹ It is intended that this will facilitate self-synchronization and shared awareness among forces in a coalition environment. Digital formatting of data was determined to be necessary to better facilitate transmission and storage of greater amounts of data.

The communications system that would be needed will have to provide for information assurance and security of the transmissions it handles. It will need to be able to secure the actual data transmissions as they move from node to node, in addition to protecting the integrity of the data that is transported. It will need to control who does and who does not have access to the system, while at the same time ensuring that data in the system will be available for use by authorized users of the system.

3. DESIGN AND ANALYSIS PHASE

Design and Analysis was the second phase in the Systems Engineering Design Process. The objective of the Design and Analysis phase was to create and evaluate potential solutions to the problem. Progress through the Design and Analysis phase was divided into the Alternatives Generation step and the Modeling and Analysis step. During Alternatives Generation, solutions to the problem are constructed and the current systems are analyzed. Under the Modeling and Analysis step, the feasible alternative solutions and the current systems are modeled and then analyzed. All the data from is

recorded and evaluated. The Design and Analysis phase resulted in feasible alternative solutions and an analysis of the benefits of potential solutions as well as current systems.

3.1 Alternatives Generation

The Alternative Generation step involved the “creative mental process of producing concepts and ideas in order to solve the problem”⁴⁴⁰. Brainstorming of potential solutions was based on system requirements and objectives. These requirements and objectives bound the design space, and a feasibility screening process imposed realistic limitations on the physical and technological characteristics of the possible system solutions. In addition to creating new solutions to the problem, the current system (or recognition of the lack of a current system) was also included as a possible solution to the problem. Following the development and selection of possible solutions, the alternatives were modeled and analyzed.

3.2 Current Communications Architecture

The primary communications system currently in use on the SURC consists of a single military radio set per craft, the AN/VRC-89, which is actually two radio set mounted within a single housing. During specific missions, a C2 craft may be designated, where it will be equipped with an additional AN/VRC-89 radio set to allow for added communications capability for the C2 element. Each craft will also have an open channel marine band VHF radio, commonly found on private and commercial vessels for safety of navigation communication with other vessels. Finally, each crewmember will be equipped with one of numerous models of commercially available personal handheld radios (similar to what you may find in use by civilian police forces), capable of being encrypted via the embedded encryption available from the manufacturer.

3.2.1 AN/VRC-89

The AN/VRC-89 (Figure E6) is a vehicle-mounted, dual-configuration radio consisting of one short-range and one long-range, solid-state, securable transceiver intended for VHF-FM tactical operations. The AN/VRC-89 provides long-range (up to 35 kilometers) and short-range (up to 8 kilometers) operation in two nets simultaneously. The AN/VRC-89 is a dual-radio configuration mounted on a single vehicular mount. It replaces existing AN/VRC-47 configurations, as well as separate configurations of AN/VRC-64 or AN/VRC-46 in a single vehicle. The AN/VRC-89 is basically two vehicular-mounted, short-range radio sets with an added power amplifier that provides one of the radio sets with a long-range communications capability up to 35 kilometers.⁴⁴¹

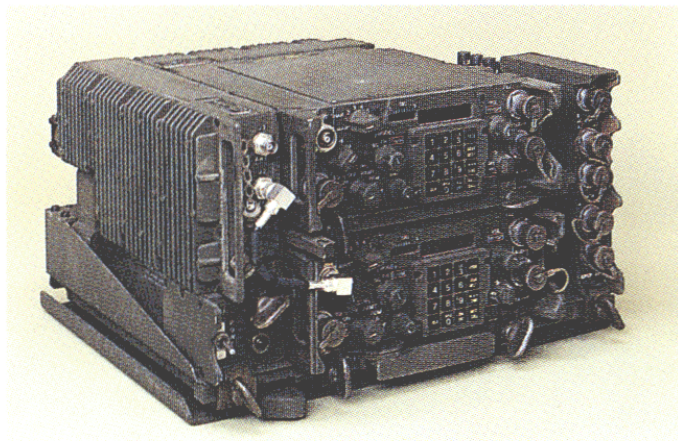

Figure E6 AN/VRC-89 Radio Set⁴⁴²

3.2.2 Riverine Craft Upgrades

As NECC takes custody of their riverine craft from the Marine Corps, they have planned an upgrade of the communications suite currently in use. They are looking to increase the communications system capacity to better handle increased amounts of data available in a tactical environment and to maximize the availability of the data to operators in the AO, to provide better overall situational awareness among units.⁴⁴³ This upgraded communications suite will be an arrangement comprised of two different

military radio sets, a commercially available marine band VHF radio, uniform personal handheld radios for intra-team communications and an onboard laptop for data handling and storage.

3.2.3 AN/PRC-117F

The AN/PRC-117F (Figure E7) multiband, multimission radio uses proprietary, Harris Software-Defined Radio (SDR) technology to provide embedded communications security (COMSEC) and satellite communications (SATCOM). It covers the entire 30 to 512 MHz frequency range, using two antenna ports. It has the capability for multiband scan and cross band/mode retransmit features, which are intended to expand the radio's operational capabilities, and a built-in-test mode that checks system performance down to the module level.

This radio is fully compatible with currently fielded cryptographic gear in both voice and data modes. The AN/PRC-117F is US National Security Agency (NSA) COMSEC-certified and is compatible with Fascinator cryptographic equipment in voice mode and the KG-84C in data mode. The radio supports both DS-101 and DS-102 cryptographic fill interfaces and all common fill devices. The AN/PRC-117F also supports a KY-57/Vinson-compatible cryptographic interface to ease backwards interoperability with older legacy equipment currently fielded. An embedded Demand Assigned Multiple Access (DAMA) and SATCOM modem is Joint Operability Test Command (JITC) certified to MIL-STD-188-181B, -182A, and -183A and is software reconfigurable to accommodate changes to these standards. Data rates up to *56 kbits/s* are supported in SATCOM. An external GPS interface accepts time and position data.

Advanced key management techniques help manage the embedded security capabilities of the transceiver. Over 170 keys can be stored and transferred by securely encrypting them using benign key fill techniques. Removal of the cryptographic ignition key (CIK), (contained in the Keypad/Display Unit (KDU)) declassifies the keyed radio. Reattachment of the KDU restores the radio to its previous operating condition.

A High Performance Waveform (HPW) is designed to securely transfer files and TCP/IP data between external computers over 5 and 25 kHz SATCOM links and 25 kHz LOS links. This waveform provides error-free data delivery using high-speed over-the-air data rates, ARQ and automatic waveform adaptation based on channel conditions. A high speed data capability over LOS channels provides up to 64 Kbps data in a 25 kHz channel.⁴⁴⁴



Figure E7 AN/PRC-117F Radio Set⁴⁴⁵

3.2.4 AN/PRC-150

The AN/PRC-150 (Figure E8) is a member of the FALCON[®] II family of NSA-certified multiband tactical radio systems. It is an HF/SSB VHF/FM equipment designed to provide reliable, long-range, secure, tactical communications. The transceiver's extended frequency range (1.6 to 60 MHz) in combination with 16 kbits/s digital voice and data enable fixed-frequency interoperability with other VHF/FM combat net radios. The AN/PRC-150 provides US Type 1 voice and data encryption compatible with ANDVT/KY-99, ANDVT/KY-100, Vinson/KY-57 and KG-84C cryptographic devices, eliminating the need for external encryption. An integral encryption mode offers secure communication interoperability with similarly equipped coalition and Partnership for Peace forces.

Communications range is improved by utilizing advanced waveforms and more robust voice encoders. Mixed Excitation Linear Prediction (MELP) 2,400 bits/s and MELP 600 bits/s are also provided for voice compression to enhance the volume of voice traffic it can handle. MIL-STD-188-1 I0B serial tone, 39-tone, ANDVT, FSK, and NATO Standardization Agreements (STANAGs) 4285 and 4415 modem waveforms are all

embedded in this radio. MIL-STD-188-141 B Appendix A Automatic Link Establishment (ALE) provides automatic calling and linking on the best available HF channel. The radio also provides 3rd generation ALE based on STANAG 4538. A removable Keypad Display Unit (KDU) provides access to controls for on-the-move operation. Operation is via a menu-driven human-machine interface (HMI). Net presets combine operating mode, frequency, COMSEC keys and modem settings under user-defined names.⁴⁴⁶



Figure E8 AN/PRC-150F Radio Set⁴⁴⁷

3.2.5 AN/PRC-152

The FALCON[®] III AN/PRC-152 (Figure E9) multiband hand-held radio utilizes the Joint Tactical Radio System (JTRS) Software Communications Architecture (SCA) and is the first radio utilizing the JTRS SCA operating environment to receive US National Security Agency (NSA) certification for the protection of voice and data traffic up to the Top Secret level.

The AN/PRC-152 single-channel, multimission radio covers the frequency range of 30 to 512 MHz and provides an adjustable transmit output power up to 5W. It supports SINCGARS, Have-Quick II, VHF/UHF AM and FM, MIL-STD-188-181B, and the High Performance Waveform (HPW) that provides 56 Kbps of data. Both Have-Quick II and VHF/UHF AM and FM waveforms are ported versions of the preliminary JTRS library waveforms, validating the AN/PRC-152's JTRS architecture

The AN/PC-152 uses the Harris Sierra[™] II software programmable encryption module. This encryption device has been designed to maximize battery life. Sierra II supports all JTRS COMSEC and TRANSEC requirements. The AN/PRC-152 also

supports numerous cryptographic device compatibility modes, including KY-57/Vinson, ANDVT/KYV-5, KG-84C, DS-101 and DS-102.

The AN/PRC-152 is able to store multiple cryptographic fill files, extending the time between reconfigurations. It can include an optional embedded GPS receiver to display local position and to provide automatic position reporting for situational awareness on the battlefield.



Figure E9 AN/PRC-152 Handheld Intra-team Radio⁴⁴⁸

3.2.6 Panasonic Toughbook CF-30 Laptop Computer

The Panasonic Toughbook CF-30 (Figure E10) is a ruggedized, weather resistant laptop computer. It is constructed using an ultra strong magnesium alloy case, is vibration and shock resistant to MIL-STD 810F and comes with a 32mm thick, foam packed Hard Disk Drive (HDD) casing, enabling it to withstand drops from a height of 90cm. A special HDD-heater allows the CF-30 to operate under extreme conditions up to -20°C while the anti-sun-reflective silver painting and the internal thermal pipe system of the unit prevent heat absorption in hot outdoor conditions. All joints and external covers have been sealed using a gasket method that creates a watertight seal with flexible elastomer to ensure dust and water resistance.

The Intel[®] Centrino architecture with wireless local area network (WLAN) allows for greater flexibility and provides optimal reception with two integrated WLAN-

antennas located in the top of the display unit. Depending on overall usage, the CF-30s durable battery has been can last up to 8.5 hours, however provisions for power to be provided from the SURC have been made. Other integrated options include Evolution Data Optimizing (EVDO), General Packet Radio Service (GPRS), Global Positioning System (GPS) and Bluetooth, enabling complete wireless mobility. 'Hot-swapping' of components is supported and allows for flexibility to swap between several optical drives and possibly a secondary battery, if needed.⁴⁴⁹



Figure E10 Panasonic CF-30 Ruggedized Laptop Computer⁴⁵⁰

Although the current communications architecture (and pending upgrade equipment) has proven reliable and rugged in a tactical environment, the equipment can be expensive and is currently operating at or near the maximum capacity for data bandwidth. Only the handheld AN/PRC-152 has the capacity to support the Wideband Network Waveform (WNW) that is planned to give the JTRS the capability of data throughput up to 3 Mbps. Also, an additional power amplification system will be needed in order for this radio to be able to broadcast to the ranges needed for the MIO scenario. Finally, the further development of the WNW had been delayed at the time of this writing and estimates on when this capability will be fully fielded were not forthcoming.⁴⁵¹

3.3 Alternative Communications Architecture

In this study, the project group utilized many brainstorming sessions to identify potential solutions to the problem. Eventually the concept of bandwidth wants and shortages initially came up in reference to the ever growing bandwidth need of people in the private sector, and what technology was being fielded to give home and corporate networks more capacity for bandwidth. This gave the group a direction in which to focus a technology search to see if there was commercially available technology that could fit into the context of our scenario as a possible solution to the problem. This resulted in the identification of the Worldwide Interoperability for Microwave Access (WiMAX) technology, which utilizes the IEEE 803.16 standard for broadband wireless access, as a possible solution. It was realized that wireless technology is fast extending network reaches by providing convenient and inexpensive access in many locations around the world. WiMAX systems provide the ability to establish high speed connectivity over longer distance than standard wireless networks utilizing the IEEE 802.11 standard. The emergence of the 802.16 family of standards is spurring widespread commercial use of WiMAX.⁴⁵² The ongoing evolution of 802.16 has the potential to expand the standard to address mobile applications, enabling broadband access directly to WiMAX-enabled portable devices ranging from smart-phones and PDA's to notebooks and laptop computers.

Further considerations were given to the commercial availability of necessary equipment for implementing use of WiMAX and how scalable this equipment would be to address the possibility of intermixed coalition forces, allowing them shared access to resulting networks as seamlessly as possible. Taking the area of operation (AO) and MIO tasking from our scenarios into consideration, our conceptual solution must be deployable in a varied riverine environment, requiring the transmission of data, voice, video and still imagery. The concept of the proposed architecture is scoped to allow for communications between the operational forces conducting the MIO operations on the river and the FOB base station only. Communications beyond the AO are assumed to be through the larger FOB communications suite via current military radio systems (to

include SATCOM) that the FOB would utilize for long range communication to higher headquarters.

The project group was able to collaborate closely with other research groups at the Naval Postgraduate School (NPS) which were actively conducting field testing on similar architectures utilizing WiMAX technology. Specifically, the Cooperative Operations and Applied Science and Technology Studies (COASTS) research group has been conducting field experiments in the jungles of Thailand; a near match for the environment of our MIO scenario. To handle all data types at the anticipated high rates of throughput via WiMAX technology, the system will need to be equipped to be able to accommodate TCP/IP data transmission, requiring network routers to be employed to link and manage all the devices that are on-board the patrol crafts. Through our interviews with the COASTS members, we were able to determine the key components necessary to facilitate incorporating a WiMAX capability into the communication capabilities of riverine forces. They recommended an architecture composed of a RedCONNEX™ AN 50e from Redline Communications, and a FortiGate™ 100A router, from Fortress Technologies as the core components, which would interface into the CF 30 laptop computers that would be part of the upgraded system on the SURC. These components would allow for a network which would have both a communications and information assurance capability.

3.3.1 RedCONNEX™ AN-50e Module

The RedCONNEX™ AN-50e module (Figure E11) enables a secure communications channel via 802.16 to be established between the FOB and riverine craft operating on the water. It operates in the 5.4 GHz and 5.8 GHz unlicensed bands and employs Orthogonal Frequency Division Multiplexing (OFDM) technology to deliver data rates of up to 49 Mbps supporting long-range operations of over 80 km in clear line of sight (LOS) conditions. This module is also capable of operating in non-line-of-sight (NLOS) and over-the-water applications. It supports point-to-point (PTP) and point-to-multipoint (PMP) broadcasting and provides site-to-site connectivity for demanding

applications including transparent local area networks (LAN), voice-over-IP (VoIP), and video streaming.⁴⁵³



Figure E11 Redline RedCONNEX™ AN-50e⁴⁵⁴

This module ensures that information is transmitted over a secured channel by providing an added security function to encrypt the channel frame control information over the 802.16 channel. This will minimize the potential for an adversary being able to obtain the frame control information, which could allow him the possibility to ‘sniff’ out data information contained within the transmission channel.

In studying the operational environment for the AO in the MIO scenario, the heavy vegetation and the surface of the river present a highly multi-path environment for a wireless transmission channel. Transmission channels in a multi-path environment are subjected to both constructive and destructive interference as the signals from the transmitter reach the receiver at different times due to the different paths that the signals takes. In addition, this spread in the time taken by each path also results in the spreading of the received signals, giving rise to inter-symbol interferences, causing a reduction of the achievable data rate to ensure that the transmission has a certain reliability of transmission. The AN-50e implements Orthogonal Frequency Division Multiplexing (OFDM) technology in its communication between the transmitter and the receiver. This technology is able to mitigate the effects of destructive interference and inter-symbol interferences caused by the presence of multiple path taken by the signals from the transmitter to the receiver, allowing a higher data rate (about 49 Mbps) to be achievable between the transmitter and the receiver, allowing for simultaneous capabilities such as

video streaming and voice communications to be employed within the patrol group and between the patrol group and FOB.

A point-to-multipoint (PMP) capability will allow the riverine craft on patrol, as Subscriber Stations (SS) to establish a communications link with the FOB Base Station from virtually any point in the AO without having to adjust the antenna to point directly from the craft to the FOB. Point to multipoint makes WiMAX as scalable and flexible as 802.11 WiFi is in the home.

The AN-50e module supports long range operations of over 80 km in clear line of sight (LOS) conditions. These performance parameters allow the establishment of 802.16 networks in the 50 km ranges specified for the AO in the scenario. Although the specified operating range of the module is 80 km, Figure E12 illustrates more realistic ranges in the riverine jungle environment in this scenario, and that the expected attainable operating range may be lower than reported by the manufacturer, yet within the ranges of the states AO of the MIO scenario.

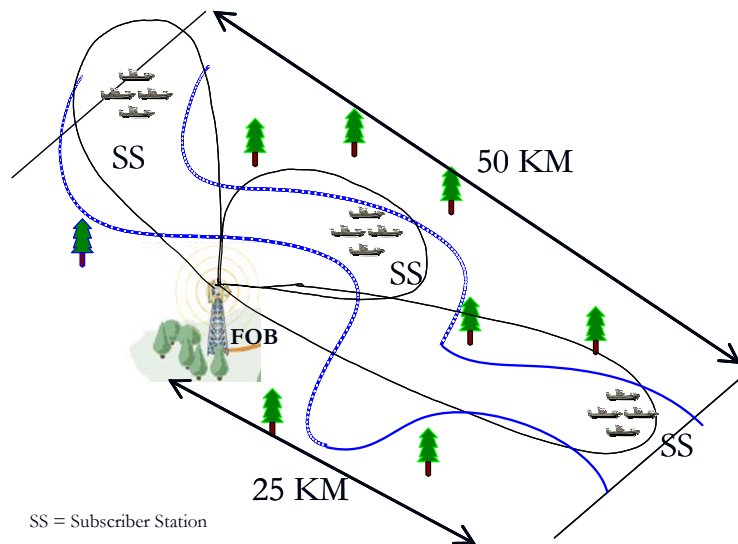

Figure E12 Expected Operating Ranges of the AN 50e Module as Applied to the Jungle Environment of the Scenario

This compromise in operating range could be due to several environmental factors. The two main factors that were taken into considerations are:

- Humidity Level: Water vapor absorbs electromagnetic energy from transmission signal waves. Higher amounts of water level are present in high humidity environments and thus, such environments will tend to degrade the maximum transmission range of any wireless communication channel.
- River Topography: Operating distances from manufacturer websites are based on ideal cases, where a clear, direct Line of Sight (LOS) is possible. However, in the actual AO, with the bends of the rivers and the height of the trees and river banks, a clear LOS may not always be possible.

Due to these considerations, operating ranges of this module is expected to be degraded to some extent. An estimation of the link budget was performed using predictive software tools provided by Redline Communications. With an understanding of the potential for bias in using vendor provided software, the results revealed that under the specified operating environment, the system is able to provide WiMAX coverage of up to 27 km radius, taking into account the addition of a 70 m tall base station antenna at the FOB.

3.3.2 FortiGate™ 100A Network Router

To be equipped for such capabilities video streaming (and video teleconferencing if needed) in any communication architecture, the architecture itself must first be able to accommodate TCP/IP data transmission. Routers would need to be employed in order to network all the subscriber stations that are deployed on the patrol craft, in addition to providing the primary security for the transmitted content.

The FortiGate™ 100A network router (Figure E13) features dual Wide Area Network (WAN) link support for redundant internet connections, and an integrated 4-port switch that eliminates the need for an external hub or switch, giving networked devices a direct connection to the FortiGate™ 100A. Dual DMZ ports provide additional network

segmentation for web and mail servers, and wireless access points with individual security and access policies for increased control of network traffic.⁴⁵⁵ This router contains several network management tools and security features integral to the unit that offer a defense-in-depth approach to security of the information transmitted via the system by placing multiple layers of protection to prevent attackers from directly attacking the system to gain access to the security critical information resources.

The FortiGate™ 100A provides a firewall capability has the ability to detect and eliminate the most damaging, content-based threats contained in email and web traffic such as viruses, worms and network intrusions in real time without degrading overall network performance. Additionally, it provides the capability to eliminate spam, viruses, spoofing, phishing, spyware and denial of service (DoS) attacks. Denial of Service (DoS) attacks were identified as the most probable threat that could disable the network. These are attacks which will render the network useless, regardless of how sophisticated the network configuration is and how high the data throughput of the system is. Hence, with the routers ability to detect and prevent over 1300 intrusions and attacks⁴⁵⁶, FortiGate™ is able to not only detect and prevent any DoS attack, but will also prevent further attacks from the adversary by blocking the Internet Protocol (IP) address the adversary may be using.

The FortiGate™ allows for data integrity and confidentiality by providing Virtual Private Networking (VPN) technology, which allows users to communicate through a secured and encrypted transmission link, effectively creating communications ‘tunnels’ directly between units. It can accommodate 80 separate VPN channels (tunnels), which will facilitate necessary scalability as units enter or leave the network. Additionally, these channels could be segregated into clusters, handling specific data types that will be transmitted on each cluster. For example, channels 1-20 could be assigned to be used for Data transmission, channels 21-40 assigned to be used for voice transmission and so-on. In addition, separate username and password controls could be set for different channel sets and hence, this could act as a form of filter to ensure that only authorized personnel will have access to a particular transmission type.

A capability for remote accessibility is a key feature of this system, which facilitates interoperability of the system among users. This capability allows for all units that are equipped with the FortiClient™ Host security software (which can be installed on any commercially available computer), secure remote access from anywhere within range of the transmission footprint. This can allow for easier scalability in the network, in the sense that minimal configuration will be required on the administrator's end whenever there is an authorized user that is within the range of the network and needs to gain access into the network.

A final feature in this device is the Dual WAN interface capability. This capability is able to provide support for 2 separate connections, providing a built-in redundancy when one of the connections goes down. When one of the connections fails, the other one automatically takes over, increasing the reliability of the architecture.



Figure E13 FortiGate™ 100A Network Router⁴⁵⁷

3.4 Concept of System Employment

The primary purpose of this proposed architecture is to enable the communication link between the patrol craft and the FOB (Figure 14). To facilitate this, patrol craft and the FOB will need to be equipped with the RedCONNEX™ AN 50e to allow for a secured communication link to be established between units. Information security on the part of the patrol craft would not require the FortiGate™ router to be installed in the craft. Instead, the FortiClient™ remote software is installed in the patrol craft laptop, and interfaces with the FortiGate™ router installed at the FOB.

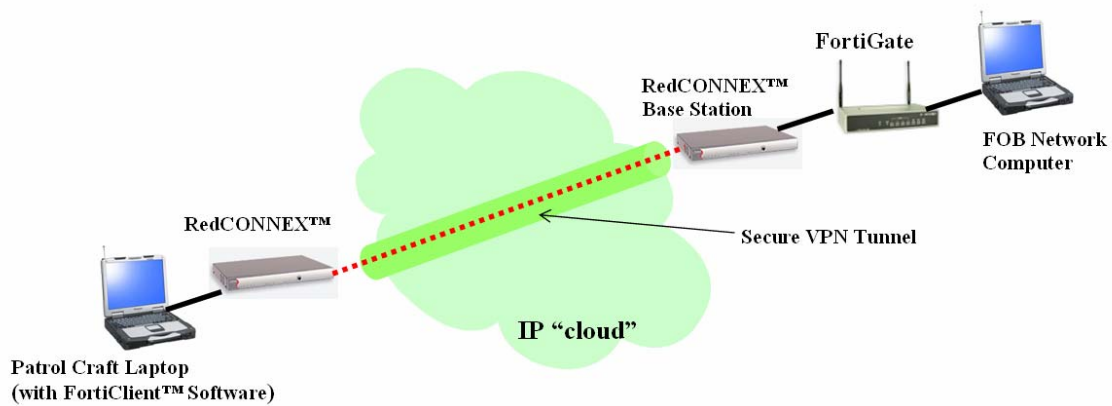

Figure E14 Conceptual Overview of WiMAX System Employment

For the patrol craft crewmen, or authorized coalition personnel to establish a secure connection via the VPN feature in the FortiClient™ software, a unique username and password will have to be assigned to each and every unit requiring authorization. This will be set up by the network administrators on each piece of gear prior to deployment of the patrol craft. For coalition partners using the system, this can be facilitated via a technical assist visit by network administrators to install and configure the RedCONNEX™ AN 50e, set up the FortiClient™ software and VPN accounts, and finally, provide initial training in the system use.

Upon initiation of the request to setup a secured VPN channel by the FortiClient™ software, the laptop will request connection from the network management feature of the FortiGate™ router at the FOB. The FortiGate™ router will request the username and password of the unit that is trying to establish the VPN channel. A session key will be sent to the client to establish a secure VPN tunnel only upon confirmation that the username and password matches to one stored in the database maintained in the FortiGate™ router.

Once this connection is established, the network is continuously monitored by the network management and security features of the FortiGate™ router and data traffic can be passed between units. Commercially available software applications can then be

utilized by personnel to interface with the data types being handled. For instance, in passing voice communication between units, VoIP software would be used as an interface through the computers and video streaming or conferencing could be conducted using Microsoft® Net-Meeting (or equivalent).

3.5 Feasibility Screening

To evaluate the alternatives considered, feasibility screening criteria were developed based on the effective need and assumed system constraints. To assist with the development of alternatives, there were characteristics that select components of the system had to possess, and were used as the system constraints. The feasibility constraints are:

- Security- The system will need to initiate and receive secure transmissions while maintaining integrity and confidentiality of the data transmitted.
- Data Throughput- The system would need to be able to pass transmission rates greater than 64Kbps.
- Ease of Interoperability- The system would need to be able to readily allow expansion of the network to authorized users without reconfiguration of equipment.

An alternative screening matrix was developed, placing the alternatives against the three feasibility screening criteria discussed above (Table E3). Each criterion of each alternative was scored “G” for good, meaning the alternative satisfied the criteria and “NG” for no good, meaning the alternative did not satisfy the criteria. Each was then recapped with an overall “G” or “NG” result. The alternative of the current system, comprised of only the AN/VRC-89, listed as satisfying the security criteria, yet it could not meet either of the criteria for throughput or ease of interoperability. The alternative of the upgraded system, comprised of the AN/PRC-117, AN/PRC-150 and AN/PRC-152 radios and Panasonic CF 30 computer, was also able to satisfy the security criteria. Although it was capable of greater throughput capacity than the AN/VRC-89, it still was

not able to satisfy the throughput or interoperability criteria. The proposed solution utilizing WiMAX was able to satisfy all three of the necessary criteria, showing that it held a greater feasibility, given the stated requirements for the scenario.

Constraints	Secure	Data Throughput >56Kbps	Ease of Interoperability	RECAP
Alternatives				
Current System (as is)	G	NG	NG	NG
Upgraded System (as planned)	G	NG	NG	NG
WiMAX (proposed)	G	G	G	G

Table E3 Alternative Feasibility Screening Matrix

3.6 Analysis of WiMAX Applicability

During the progression of the study, numerous unanticipated delays were encountered while attempting to accurately define the problem and identify alternatives. This led to the project group not having as much time as would have been ideal to conduct a thorough quantitative analysis of the proposed system. It was determined that a qualitative analysis would be conducted with the time remaining, to get a feel for whether the WiMAX system would be feasible as a communication architecture. This was done via the Analytical Hierarchy Process (AHP).

The Analytic Hierarchy Process is a powerful decision making tool for problem solving and decision making in a complex environment. It provides a proven, effective means to deal with complex decision making and can assist with identifying and weighting selection criteria, analyzing the data collected for the criteria and expediting the decision-making process. It can capture both subjective and objective evaluation

measures, providing a useful mechanism for checking the consistency of the evaluation measures and alternatives suggested by the team, reducing bias in decision making.

3.7 Analysis Criteria Formulation

To facilitate an analysis between the upgraded system and the proposed system, four prime criteria for measurement were identified. They are security, transmission capability, receive capability and interoperability. These criteria were determined to be essential for the operation of the communication system in the riverine AO.

- Security- It is essential that a wireless network is secured from any form of network attack. This criterion identifies how well data is being protected during transmission, level of data confidentiality, level of data integrity, and data availability and authenticity.
- Transmission capability- In the riverine AO, it is necessary that the system is able to transmit the required signals of voice, video and data, to the receiver located as far as 25 km radius from the transmitter. Thus, transmission capability measures how well voice, video and data is being transmitted to the receiver.
- Receive capability- This is the reverse of transmission capability. It measure how well the receiver, located at 25 at away from the transmitter is able to receive voice, video and data from the transmitter.
- Interoperability- The condition achieved among communications-electronics systems or items of communications-electronics equipment when information or services can be exchanged directly and satisfactorily between them and/or their users.⁴⁵⁸ It also involved the scalability of the system. This criterion identifies the degree of interoperability of the system with other systems and coalition partners.

3.7.1 Preference Weight

In a multi decision problem such as AHP, it is a requirement to judge the relative importance or priority on the set of criteria. The degrees of importance or priority are judged in the form of a set of weights. To compare the importance of each criteria, a pair-wise comparison reciprocal matrix is created (Table E4), after which normalized weights are computed using the approximation method of Row Geometric Mean (RGM) approximation method. Sub matrices will be eventually be created for each criteria.

Criteria	Security	Tx	Rx	Interoperability	RGM	Normalized Weight
Security	1.00	2.00	2.00	4.00	2.000	0.434
Transmission (Tx)	0.50	1.00	2.00	3.00	1.316	0.286
Receive (Rx)	0.50	0.50	1.00	2.00	0.841	0.182
Interoperability	0.25	0.33	0.50	1.00	0.452	0.098
					4.609	1

Table E4 Pair-wise Criteria Comparison

The main pair-wise comparison matrix shows how the relative importance between each criterion is specified. The values for the importance of each of the criteria was determined through stakeholder survey response and through consultation with panels of subject matter experts, composed of faculty and students from the Naval Postgraduate School (NPS).

In a military operational environment, information security was judged as the prime consideration, thus security is specified as 2 times more important than transmission and receive capability and 4 times more important than interoperability. Transmission and receive capability are given the same importance as they are interdependent. Interoperability is rated less important as the other criteria for the operation of a communication system. This led to the formulation of the first sub-matrix

for rating the security capability of each system (Table E5). This sub-matrix is to determine a score for the security level of the communication systems. A system is rated outstanding if it meets all security requirements of data confidentiality, data integrity, data availability and data authenticity. A system is rated average if it meets only some of the requirements. An unsatisfactory rating is for systems that do not meet any of the requirements. The normalized weight of outstanding is 1, average is 0.405 and unsatisfactory is 0.164.

					Normalized Weight	
Security	Outstanding	Average	Unsatisfactory	RGM	Dist	Ideal
Outstanding	1.00	3.00	5.00	2.466	0.637	1.000
Average	0.33	1.00	3.00	1.000	0.258	0.405
Unsatisfactory	0.20	0.33	1.00	0.405	0.105	0.164
				3.872		

Table E5 Security Criteria Comparison Sub-Matrix

The transmission (Table E6) and receive (Table E7) capability are measured in terms of the system's ability to transmit and receive video streams, voice communications, and analog information and digital information. Video streaming was determined to be a slightly more crucial requirement in a MIO operation as it could immediately transmit real time situational update to the command element. Voice communication is rated second most important as it would provide for coordinating instruction to be communicated.

						Normalized Weight	
Tx	Video	Voice	Analog	Digital	RGM	Dist	Ideal
Video	1.00	2.00	4.00	5.00	2.515	0.494	1.00
Voice	0.50	1.00	3.00	4.00	1.565	0.307	0.62
Analog	0.25	0.33	1.00	0.50	0.452	0.089	0.18
Digital	0.20	0.25	2.00	1.00	0.562	0.110	0.22
					5.094		

Table E6 Transmission Criteria Comparison Sub-Matrix

						Normalized Weight	
Rx	Video	Voice	Analog	Digital	RGM	Dist	Ideal
Video	1.00	2.00	4.00	5.00	2.515	0.494	1.00
Voice	0.50	1.00	3.00	4.00	1.565	0.307	0.62
Analog	0.25	0.33	1.00	0.50	0.452	0.089	0.18
Digital	0.20	0.25	2.00	1.00	0.562	0.110	0.22
					5.094		

Table E7 Receive Criteria Comparison Sub-Matrix

The following four matrices compare results between the existing system and proposed WiMAX system of the previous sub-matrices. The proposed system is capable of transmitting video stream while the existing system is unable to do so. Thus it is rated as five times better than the existing system (Table E8).

Video	Existing system	Proposed system	GRM	Normalized Weight
Existing system	1.00	0.20	0.45	0.167
Proposed system	5.00	1.00	2.24	0.833
			2.68	

Table E8 Sub-Matrix Comparison for Video Capability

Both systems are capable of provide quality voice communication therefore they have the same rating (Table E9).

Voice	Existing system	Proposed system	GRM	Normalized Weight
Existing system	1.00	1.00	1.00	0.373
Proposed system	1.00	1.00	1.00	0.373
			2.00	

Table E9 Sub-Matrix Comparison for Voice Capability

Both systems are capable of provide quality analog communication, therefore they have the same rating (Table E10).

Analog	Existing system	Proposed system	GRM	Normalized Weight
Existing system	1.00	1.00	1.00	0.373
Proposed system	1.00	1.00	1.00	0.373
			2.00	

Table E10 Sub-Matrix Comparison for Analog Capability

The proposed system is capable of transmitting digital information such as email and instant short message, etc, while the existing system is limited in its capacity to do so. Thus it is rated as five times better than the existing system (Table E11).

Digital	Existing system	Proposed system	GRM	Normalized Weight
Existing system	1.00	0.20	0.45	0.167
Proposed system	5.00	1.00	2.24	0.833
			2.68	

Table E11 Sub-Matrix Comparison for Digital Capability

The overall transmission and receiving capability weighting (Table E12) for both the existing and proposed system was then able to be determined. It is seen that the proposed system is able to satisfy all requirements thus has the higher weight.

Tx/Rx	Video	Voice	Analog	Digital	Overall Weight
	1.00	0.62	0.18	0.224	
Existing system	0.167	0.373	0.37	0.167	0.503
Proposed system	0.833	0.373	0.37	0.833	1.319

Table E12 Sub-Matrix Comparison for Transmission and Receiving Capability

The interoperability of the communication systems was next rated (Table E13). A system is rated outstanding if it able to easily interoperable with other system or if it is scalable. A system is rates average if it requires substantial technical configuration or setup before it could interoperate with other system, or not scalable in being able to change as units enter or leave the network. Below average is for a system that is not interoperable and scalable. The normalized weight of outstanding is 1, average is 0.405 and unsatisfactory is 0.164.

					Normalized Weight	
Interoperability	Outstanding	Average	Below Average	RGM	Dist	Ideal
Outstanding	1.00	3.00	5.00	2.466	0.637	1.000
Average	0.33	1.00	3.00	1.000	0.258	0.405
Below Average	0.20	0.33	1.00	0.405	0.105	0.164
				3.872		

Table E13 Sub-Matrix Comparison for Interoperability

Finally, the overall score of the system (Table E14) based the above weights could be determined. Security and interoperability for the existing system was rated as

average as it provided limited security and required reconfiguration of the system before it could interoperate with other systems. Security and interoperability for the proposed system are rated as outstanding and average, respectively, based on the layered security features being included in the design and thus, in the final scoring, the proposed system gained a higher score as it better satisfied the specified system requirements.

	Security	Tx	Rx	Interoperability	Overall Score
Baseline Weight→	<i>0.434</i>	<i>0.286</i>	<i>0.182</i>	<i>0.098</i>	
<u>Existing System</u>	Average			Average	
Weight	0.405	0.503	0.503	0.405	0.451
<u>Proposed System</u>	Outstanding			Average	
Weight	1.000	1.319	1.319	0.405	1.091

Table E14 Final Comparison of Communication Systems

4. CONCLUSIONS

Although the time constraints of this study limited the extent of the depth that was able to be investigated concerning technologies available for alternative communications architectures, the project group felt that much useful information was gained. The communications equipment in use by the riverine forces in tactical environments, though tried and proven in the field, is designed around dated military technologies that support a communications doctrine consistent with the periods they were developed. However, as time and technology have advanced, the information demands of battlefield environments have grown to the point of dwarfing the capacities of legacy systems that seem to only be able to advance their capacity through lengthy development time and increased financial investment. It is felt that this study supports a more thorough investigation into the development of commercially available technologies as alternative communications architectures, especially considering the rapid pace at which these technologies now seem to be developed.

The scenario used with this study was merely representative and it would have been preferable to examine the systems under more varied scenario application. Also, hard data that could have been used if it were available; however, the testing that the data would result from was still in progress.

Currently there is room for WiMAX technology to mature to meet greater needs of military forces. The certification of a mobile standard for 802.16 is nearing final acceptance and holds the potential for further advancing tactical use of wireless networking on more and more varied mobile platforms. It also holds great promise as a potential conduit for smaller units to interface with the Global Information Grid (GIG), being implemented.

WiMAX systems face several obstacles to acceptance as a tactical communications network. Being a newer technology, it is understandably not seen as having the maturity of the current technologies, and will require much testing and successful exposure to overcome. This feeds into one of the biggest obstacles to its acceptance and that may be the paradigms that operators have toward the use of current systems. These legacy systems have been in service for many years and have the advantage of being tried in the combat environments that operators expect, and the fact that the newer upgrades are produced by the same manufacturer gives a certain degree of confidence. This is compounded by the visibility that 802.11 wireless technology has acquired in the commercial market as being highly susceptible to security problems from 'hacking', viruses, interception and exploitation.

5. RECOMMENDATIONS FOR FURTHER RESEARCH

Although the investigation supporting this study showed promise, additional research and testing is required to determine if WiMAX is fully compatible with the riverine forces concept of employment. In addition to construction and field testing of the proposed WiMAX architecture in this study, further research should also focus on the following:

1. Cost Analysis- It is anticipated that the financial cost associated with acquiring and maintaining this technology will decrease as it matures. Costs

for outfitting and supporting a fully deployable riverine force should be analyzed and compared to other systems in currently in use to determine the economic feasibility of this technology. This should take into account the fact that coalition partners would either have to purchase or be provided the RedCONNEX™ module.

2. Relay Development- The need for a 70m antenna as part of the FOB could be avoided altogether if relay platforms were available to mitigate blind areas that may develop due to topography or obstacles. The lengthening operational loitering abilities of Unmanned Aerial Vehicles (UAV's) could be further developed to include relay nodes for WiMAX transmissions. This would need to be in conjunction with advancing developments in power cell technologies and micro-miniaturization of electronic components. In this way, UAV's could loiter on station above riverine forces and allow them to relay broadband WiMAX transmissions over obstructions.
3. WiMAX Amplification- Development of ways to amplify the transmission signals of WiMAX systems would greatly expand on the usable signal ranges that could be achieved. This would provide a certain measure of greater operational flexibility to operational forces conducting riverine operations.
4. Vulnerability Assessments- Information assurance is a very important concern for wireless technologies. Vulnerabilities are expected to become apparent as this technology matures and becomes increasingly available. It is felt that this warrants research into identifying and mitigating security issues with this technology.
5. Ruggedization- WiMAX equipment currently available is designed around use in expanding the productivity of commercial corporations, and is thus, designed to be installed within fixed facilities where it is protected from environmental factors and movement. Developing methods of making this equipment capable of handling the varied environments which are inherently hostile toward electronic equipment. This should include heat dissipation and waterproofing in addition to shock absorption.

6. Other Equipment Sources- The pace at which WiMAX technology is growing, and as interest in this technology use grows in commercial industry, it is anticipated that more companies will begin to develop and make available alternative components with WiMAX capability, that may have improved performance or lower cost than the equipment looked at in this study.
7. COASTS Integration- The COASTS group at NPS regularly conducts field testing of equipment for the propose of increasing coalition interoperability. It is recommended that groups looking into the development of WiMAX use in a tactical environment combine their efforts with the COASTS group to develop WiMAX architectures and integrate them into field scenario testing.

⁴³³ W.T.T. Pakenham, *Naval Command and Control: Volume Eight*, (London: Brassey's Defense Publishers, 1987), 69.

⁴³⁴ Marine Corps Warfighting Lab. “Distributed Operations 2006 Capabilities and Enhancements Report.”, July 17, 2006, http://www.mcwl.usmc.mil/SV/DO%20CapEnhncRpt_19%20Jan%2005.pdf, (accessed: March 15, 2007).

⁴³⁵ U.S. Navy Riverine Force, *Concept of Operations* (Little Creek, VA: GPO, 2006), 39.

⁴³⁶ JTRS, Joint Program Office Brief. “JTRS: Program Status”, http://spacecom.grc.nasa.gov/icnsconf/docs/2003/11_D2/D2-06A-Harrison.pdf.

⁴³⁷ Congressional Budget Office, “The Army’s Bandwidth Bottleneck,” <http://www.cbo.gov/showdoc.cfm?index=4500&sequence=5>.

⁴³⁸ Lieutenant Commander Herve Lara, in discussion with the authors, 23 January 2007.

⁴³⁹ U.S. Department of Defense, *Joint Publication 1-02: Department of Defense Dictionary of Military and Associated Terms*, 1 March 2007 (Washington, D.C.: GPO, 12 April 2001), 273.

⁴⁴⁰ Eugene Paulo, “Alternative Generation,” SI4001 Introduction to Systems Engineering, Supplemental Class Notes, (Naval Postgraduate School, 10 July 2006), slides.

⁴⁴¹ Olive-Drab Military Reference, “Military Radios: Vehicular SINCGARS,” *Olive-Drab.com*, http://www.olive-drab.com/od_electronics_sincgars_v.php.

⁴⁴² Army.mil, “SINCGARS RT-1439 Non-ICOM Radio,” *Army.mil*, <http://www.monmouth.army.mil/peoc3s/trcs/SINCRT1439/niweb.htm>.

⁴⁴³ Captain David Balk, in discussion with the authors, 29 March 2007.

⁴⁴⁴ Jane’s Information Group, “AN/PRC-117F Multiband, Multimission Radio,” *Janes.com*, http://www8.janes.com/Search/documentView.do?docId=/content1/janesdata/yb/jmc/jmc_0242.htm@current&pageSelected=allJanes&keyword=an%2FPRC-117F&backPath=http://search.janes.com/Search&Prod_Name=JMC&.

⁴⁴⁵ Olive-Drab Military Reference, “AN/PRC-117,” *Olive-Drab.com*, http://www.olive-drab.com/od_electronics_anprc117.php.

⁴⁴⁶ Jane’s Information Group, “AN/PRC-150(C) HF/VHF Tactical Radio System,” *Janes.com*,

http://www8.janes.com/Search/documentView.do?docId=/content1/janesdata/yb/jmc/jmc_5237.htm@current&pageSelected=allJanes&keyword=an%2FPRC-150&backPath=http://search.janes.com/Search&Prod_Name=JMC&.

⁴⁴⁷ Harris Corporation, “AN/PRC-150,” *Harris Corporation*, <http://www.rfcomm.harris.com/products/tactical-radio-communications/ANPRC150-brochure.pdf>.

⁴⁴⁸ Jane’s Information Group, “AN/PRC-152,” *Janes.com*, <http://www8.janes.com/janesdata/yb/jmc/images/p1123713.jpg>.

⁴⁴⁹ Panasonic, “Panasonic Toughbook 30,” *USAT*, <http://www.usatcorp.com/products/panasonic.asp>.

⁴⁵⁰ Panasonic, “Panasonic Toughbook 30,” *USAT*, <http://www.usatcorp.com/products/panasonic.asp>.

⁴⁵¹ Captain David Balk, in discussion with the authors, 29 March 2007.

⁴⁵² Redline Communications, “Secure Wireless Solutions,” *Redline Communications*, www.redlinecommunications.com/news/resourcecenter/appnotes/CaseStudy_Fortress.pdf.

⁴⁵³ Redline Communications, “Product Brochures and Datasheets,” *Redline Communications*, <http://www.redlinecommunications.com/news/resourcecenter/productinfo.html>.

⁴⁵⁴ Redline Communications, “AN-50e,” *Redline Communications*, <http://www.redlinecommunications.com/products/AN50e.html>.

⁴⁵⁵ Fortiwall Internet Security, “FortiGate 100A 24x7 Bundle,” *Fortiwall*, <http://www.fortiwall.com/ProductCart/pc/viewPrd.asp?idcategory=27&idproduct=4905>.

⁴⁵⁶ Fortiwall Internet Security, “FortiGate 100A 24x7 Bundle,” *Fortiwall*, <http://www.fortiwall.com/ProductCart/pc/viewPrd.asp?idcategory=27&idproduct=4905>.

⁴⁵⁷ Fortiwall Internet Security, “FortiGate 100A 24x7 Bundle,” *Fortiwall*, <http://www.fortiwall.com/ProductCart/pc/viewPrd.asp?idcategory=27&idproduct=4905>.

⁴⁵⁸ U.S. Department of Defense, *Joint Publication 1-02: Department of Defense Dictionary of Military and Associated Terms*, 1 March 2007 (Washington, D.C.: GPO, 12 April 2001), 273.

INITIAL DISTRIBUTION LIST

1. Defense Technical Information Center
Arlington, VA
2. Dudley Knox Library
Naval Postgraduate School
Monterey, California
3. Commander Fleet Forces Command
Norfolk, VA
4. Commander, Naval Expeditionary Combat Command
Norfolk, VA
5. Commander, Riverine Group ONE
Norfolk, VA
6. Commander, Naval Special Warfare Group FOUR,
Norfolk, VA
7. OPNAV N851
Washington, DC
8. PEO, Littoral and Mine Warfare
Washington Navy Yard, DC
9. Commanding Officer, Naval Special Warfare Group ONE Logistics Support Unit,
San Diego, CA
10. Commander, Naval Coastal Warfare Group ONE
San Diego, CA
11. Commander, Naval Coastal Warfare Group TWO
Portsmouth, VA
12. Center For Naval Analyses
Alexandria, VA
13. Office of Naval Research
Arlington, VA
14. Commander, Surface Warfare Development Group
Norfolk, VA

- 15. Commander, Naval Surface Warfare Command
Newport, RI

- 15.16. Commander, Dahlgren Division
Naval Surface Warfare Center
Dahlgren, VA

- 16.17. Port Hueneme Division
Naval Surface Warfare Center
Port Hueneme, CA

- 17.18. Carderock Division
Naval Surface Warfare Center
West Bethesda, MD

- 18.19. Mr. Matthew Hawkins
Norfolk, VA

- 19.20. Mr. Andrew Ulak
Norfolk, VA

- 20.21. Mr. Mike Massocco
Norfolk, VA