

# A Platform Across the Valley of Death: Tech Transition via Open Enterprise Information System Development

---

By Chris Gunderson, Naval Postgraduate School, Department of Information Science  
On behalf of the Undersecretary of Defense for Intelligence

## Abstract

Achieving “Tech Transfer”, defined as “an invention usefully adopted,” is difficult, particularly within the Defense Enterprise. The Defense acquisition system is designed to transition technology through a long serial process that is especially ill suited for Information Technology (IT). However, there is a successful commercial practice for transitioning newly invented IT called “Product Line Architecture” (PLA). PLA optimizes a specified open standard technical framework around specific, measurable, enterprise business objectives and streamlined bureaucratic process. There are no legal or technical barriers that prevent the Defense Enterprise from adapting PLA to leverage the IT marketplace for transition of information centric capabilities. However, several fundamental paradigm shifts in policies and perceptions are required, namely:

- Specify open system approaches in context with measurable and testable business objectives, as part of procurement requirements i.e. Defense Enterprise PLA.
- Virtualize inheritable security controls into open standard IT infrastructure.
- Base procurement award and performance incentives on demonstrated Validation and Verification (V&V) against value-based metrics, including for reuse of existing components and infrastructure.
- Apply expert systems technologies -- per Computer Assisted Design (CAD), TurboTax, and workflow automation -- to automate the Enterprise Information System (EIS) design and compliance process.
- Establish a persistent, distributed, “PlugTest” virtual environment based on Defense Enterprise PLA to implement and nurture eco-system per all the above.
- Use the PlugTest environment as a channel to catalyze a COTS marketplace around Defense Enterprise IT requirements writ large.

## Table of Contents

|  |           |
|--|-----------|
| <b>Abstract.....</b>   | <b>1</b>  |
| <b>Table of Contents .....</b>                                     | <b>2</b>  |
| <b>Table of Figures.....</b>                                       | <b>3</b>  |
| <b>Introduction: Survival of the Fittest.....</b>                  | <b>4</b>  |
| <b>What is Successful Technology Transition? .....</b>             | <b>4</b>  |
| <b>Transition vs. Transfer .....</b>                               | <b>4</b>  |
| <b>How to Cross the Valley and the Trough .....</b>                | <b>6</b>  |
| <b>DoD's Deeper Valley and Wider Trough.....</b>                   | <b>7</b>  |
| <b>Building Blocks for the Bridge.....</b>                         | <b>11</b> |
| <b>Success Defined.....</b>  | <b>11</b> |
| <b>The Bridge Design: Product Line Architecture.....</b>           | <b>12</b> |
| <b>Einsteinien Action .....</b>                                    | <b>15</b> |
| <b>Incentivize Open System Approach .....</b>                      | <b>16</b> |
| <b>Measure the Right Things.....</b>                               | <b>16</b> |
| <b>Pay for the Right Things the Right Way .....</b>                | <b>17</b> |
| <b>Virtualize and Standardize Security .....</b>                   | <b>17</b> |
| <b>Manage Tech Transition in a Brown Field.....</b>                | <b>18</b> |
| <b>Automate Design, Engineering Workflow, and Compliance .....</b> | <b>18</b> |
| <b>Move from Monopoly to Market.....</b>                           | <b>20</b> |
| <b>Works Cited .....</b>   | <b>22</b> |

## Table of Figures

|   |    |
|---|----|
| Figure 1: Gartner's Hype Curve. The Trough of Disillusionment is analogous to the Valley of Death.....  | 7  |
| Figure 2: Basic components (comments are the author's) of the Defense acquisition system from 2013 interim guidance pending new policy.....   | 9  |
| Figure 3: Product Line Architecture provides a platform to transition inventions immediately to adoption. Successful new components often evolve to become elements of infrastructure .....   | 13 |
| Figure 4: Diagram from 2013 interim guidance for Defense acquisition system (comments are the author's.) This approach inserts the "square peg" of iterative software development in the round hole of a traditional waterfall model.....   | 20 |
| Figure 5: Conceptual model for using the COTS IT marketplace, and Defense enterprise PLA, to hold competition, perform AoA, do risk mitigating prototyping, pre-certifying useful components, and conveniently procuring lifecycle supported capability to programs across the Defense acquisition portfolio..... | 22 |

## Introduction: Survival of the Fittest

The Industrial Age is over and the Information Age is underway. Many old enterprises have not survived the transition. Today's thriving enterprises do so by adapting to the new environment. Non-state terror organizations are among those that have adapted well. (United Nations Office on Drugs and Crime, 2012)

The new environment is virtual, distributed, information-centric, and evolving dynamically. From an information systems engineering perspective, the gene pool for enterprise evolution is the Information Technology (IT) marketplace. Metaphorically speaking, Open Enterprise Information Systems (OEIS) can serve as the cauldrons for stirring the primal evolutionary soup. The World Wide Web, after all, is the mother of all OEIS! Following this argument, successful system evolution is equivalent to "Technology Transition." Achieving information-centric tech transition requires understanding and executing some fundamental departures from industrial age system development paradigms. For example:

- Develop enterprise, or in-line, rather than point solutions
- Build open systems rather than closed systems
- Harvest and recompose successful off-the-shelf components to create new capability.

According to many watchdog reports and Congressional mandates, the Defense Enterprise, unlike non-state terror organizations, has fallen far behind at evolving enterprise information-centric capability.

## What is Successful Technology Transition?

### Transition vs. Transfer

"Invention" and "innovation" are similar, related terms. "Invention" is often defined as creation of a new artifact, and "innovation" as useful application of the invention. In other words, an innovation is an invention that has been adopted in a way that changes prior behavior.

"Technology Transfer", and "Technology Transition" are, likewise, closely related terms. *Transition* of an invention is equivalent to adoption of the invention by a community of practice. An invention that becomes an innovation has, thus, been transitioned. *Transfer* of technology typically means that Intellectual Property (IP)

moves from the technology developer to the technology applier. This transfer may be formal or informal, deliberate or accidental, voluntary or co-opted, and legal or illegal. An academic or government laboratory might allow a commercial firm, and/or another government or academic lab, etc., to use its invention for agreed purposes. Alternatively, the IP might be released freely into the public domain, or be involuntarily reverse engineered by technology pirates. In the Defense Enterprise, transition often is the unintended consequence of COTS IT procurement, even though virtually no transfer occurs. Exploitation of this opportunity can be one of the most effective approaches for meaningful tech transition. Regardless, per the following examples, *tech transfer* is an often useful, but certainly not sufficient condition for *tech transition*.

For example, government-funded research at Rand Corporation led to the invention of packet switching technologies in the early 1960's. The IP *transferred* to the DoD's Advanced Research Projects Agency (ARPA). It also *transferred* to what eventually became the Open Systems Interconnections (OSI) committee of the International Standards Organization (ISO).

The OSI committee represented a huge international government and industry collaborative, including the US DoD. The OSI committee's goal was to transition packet switching technology via an invention called "virtual circuits". Their approach was to gain consensus on a comprehensive suite of standards that could then be widely implemented. In fact, in 1988 the US Department of Commerce mandated that all US government computers must use OSI standards. However, implementation of OSI standards turned out to be expensive and difficult. Virtual circuit technology never transitioned. By contrast, the ARPA-net project implemented packet switching technology with two inventions called "Transmission Control Protocol" (TCP) and "Internet Protocol" (IP). TCP/IP was cheap and easy to use, so people adapted it for any number of useful purposes. Standardization occurred *after* early adoption. Therefore, the Department of Commerce mandate to use OSI standards became moot. (Russell, 2013)

Similarly, government-funded research led to the discovery of satellite navigation technology. That raw technology was *transferred* to the DoD laboratories that developed the Global Positioning System (GPS). The DoD *transferred* access to the GPS "selective availability" (previously restricted precise data) to the general public in 2000.

The GPS system *transitioned* satellite navigation technology by publishing message and data formats that made it freely and easily available to the public. Myriad innovative products and services consumed the GPS navigational data and turned it into extraordinarily, convenient, useful and lucrative utilities

Standards for the Internet, search engines, GPS and other related technologies have evolved, and continue to evolve, following the initial adoption of demonstrated capabilities. In these cases, commercial industry's innovative technology adoption,

and follow on standards evolution, has exponentially enhanced the government's ability to harvest the potential value of the technology the taxpayers paid to invent.

## How to Cross the Valley and the Trough

The difficulty of transitioning a promising new invention into a useful and sustained utility is well documented. In fact, this transition is so difficult that literature often refers to the issue as "The Valley of Death." The consulting company, Gartner, has invented a similar concept to describe the difficulty of transitioning IT called the "Hype Curve." Inevitably, according to Gartner, the novelty of some newly invented IT generates excitement. The hype increases with speculation over its potential applications. The hype dies down in light of failure to immediately live up to expectations. Gartner calls the long difficult period between the peak of the hype and the slow climb toward useful adoption (in those cases where adoption indeed occurs) the "Trough of Disillusionment." (See figure: 1)

Arguably Clayton Christensen's famous book "The Innovator's Dilemma" offers useful insight for crossing both the Trough of Disillusionment and the Valley of Death. Christensen describes the problem in context with "disruptive technology." A disruptive technology is one whose adoption fundamentally changes community behavior. (Christensen, 2003) Inventors love it when their inventions become disruptive. On the other hand, those vested in the status quo fear disruptive inventions that threaten their comfortable business models. For example, Defense budgetary processes typically cite maintenance of status quo capabilities as justification for continued investment. Traditional Defense contractors are comfortable with that status quo. Hence deliberate adoption of disruptive technologies within the Defense investment is problematic. Christensen's best practices for catalyzing disruptive innovation include the following:

- Target potential early adopters at the low end of the market who are underserved by, and not vested in, the status quo.
- Provide a solution that is cheaper and/or more convenient than the status quo.
- Implement the innovation via familiar methods that are comfortable to the implementers on one hand, and won't raise defenses of the old guard on the other.

The Internet, GPS, and web services are disruptive technologies that became broadly and usefully adopted as the fabric of the World Wide Web (WWW). The likes of Amazon, iTunes, TurboTax, Travelocity, eBay, etc., have leveraged Christensen's tenants, within the framework of WWW, to disrupt the brick-and-mortar retail industry.

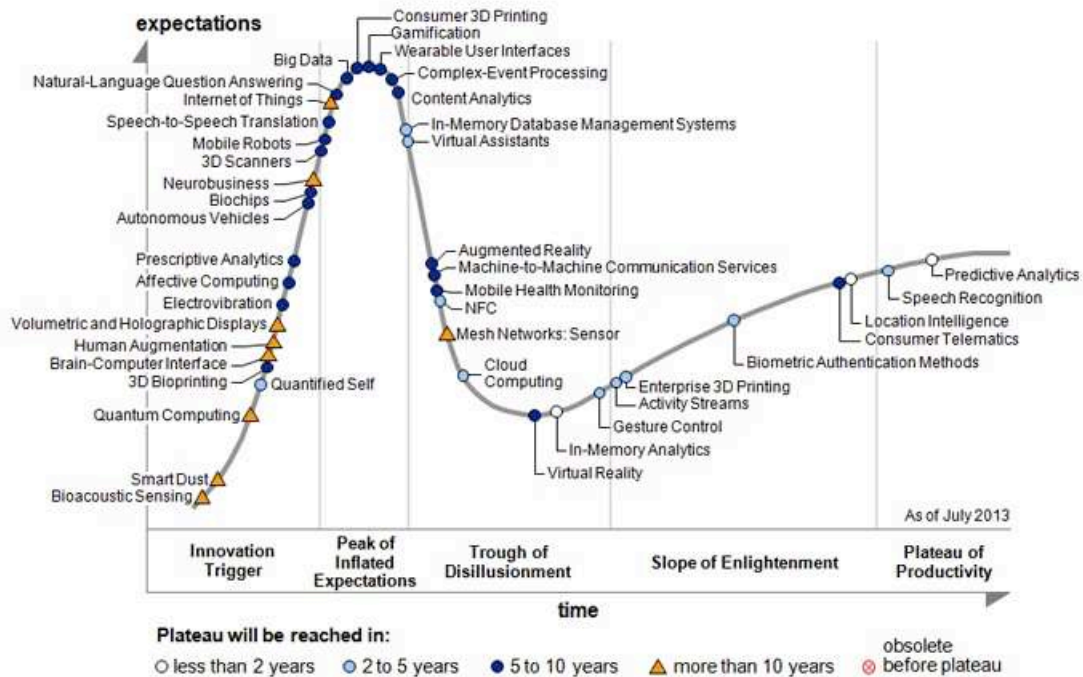

Figure 1: Gartner's Hype Curve. The Trough of Disillusionment is analogous to the Valley of Death

### DoD's Deeper Valley and Wider Trough

The US Defense Enterprise began continuous and significant investment in scientific research and associated engineering early in the twentieth century. Radar, sonar, the atomic bomb, GPS, TCP/IP, and the search engine are examples of the technologies that transitioned from this Defense investment. The continuing Defense investment in technology discovery is called the "Science and Technology" (S&T) process.

The Defense Enterprise can follow essentially two paths to tech transition. Intellectual Property (IP) developed at government expense can transition via direct commercialization. It can also transition via the "Program of Record" (POR) wherein Defense Systems get built with government-developed IP. The Federal Acquisition Regulations (FAR) mandate that government programs leverage Commercial-off-the-Shelf (COTS) technology whenever possible. The FAR further encourages that IP developed at government expense be made as widely available to the public as possible. (US Federal Government) The implication is that transition via direct commercialization is preferred. However the two paths to transition are not necessarily mutually exclusive. POR's can certainly transition technology by

investing in commercial firms to evolve generic COTS products that address requirements for Defense systems. Indeed, that often happens as a stopgap measure necessitated by schedule and budget over runs, or emergencies. In these cases effective transition occurs essentially by accident, without a strategy for continuously refreshing the COTS.

Famous historical successes and accidental opportunities at tech transition notwithstanding, in general the Valley of Death plagues the Defense acquisition process. (National Research Council, 2004) Defense programs' tend to invest in information technologies while they are still near the top of the Hype Curve. That tendency contributes to the issue. (GAO, 2006) Watchdog reports have suggested changes to the Defense acquisition process to better cope with the rapid evolution of IT. (Defense Science Board, 2009) Many Defense and other government offices have responded with enlightened policies that aim to adapt commercial best practices for rapid, evolutionary, development. (Office of the Secretary of Defense, 2010) These intentions notwithstanding, so far success has been limited. (Powner, 2014) In particular, DoD has acknowledged that it is generally unable to implement its envisioned rapid, incremental delivery of IT-enabled capability. (GAO, 2014)

DoD's process for spanning the Valley of Death via POR is called the "Acquisition System." In this system, a POR proceeds serially from "Research and Material Solution Analysis" through "Milestone A" (MS A) into "Technology Development" for risk reduction. The process continues through "MS B" into "Engineering & Manufacturing Development" through "MS C". "Operational Test & Evaluation" (OT&E), and Interoperability Testing follow MS C and precede "Production and Deployment." Initial Operating Capability (IOC) is next, followed by "Operations and Support." (Department of Defense (DoD), 2013) (See figure: 2) The end-to-end process takes years and is subject to frequent cost and schedule over runs, and re-baselining. (Department of Defense, 2014)

The DoD acquisition process includes differing categories of funds, each with its own strict fiscal governance. Research and Development, Test and Evaluation (RDT&E) funds are used generally for discovery, prototype development and risk reduction. Procurement funds are used generally to develop and manufacture delivered capability. Operations and Maintenance (O&M) funds are used to sustain delivered capability.



Documentation for each milestone decision takes a long time to develop and is expensive. It tends to be redundant, especially for information systems. Why not automate across the Defense Enterprise per Computer Assisted Design (CAD) for engineering, and TurboTax for compliance?

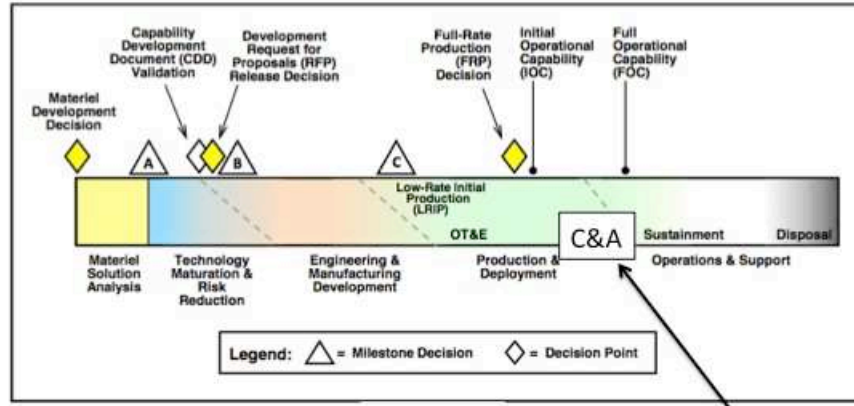

1 – 2 years for Information Assurance (IA) Certification and Accreditation (C&A). Every time IT is refreshed, C&A must also be refreshed. C&A artifacts do not transfer across systems? How about an open standard virtual security layer?

Figure 2: Basic components (comments are the author’s) of the Defense acquisition system from 2013 interim guidance pending new policy

Theoretically, technology developed via the S&T process may enter the POR Acquisition System at any point in the process, however it typically enters during the Technology Maturation and Risk Reduction phase. Practitioners within the S&T process often equate transfer of their technology to the POR as “transition.” (US GAO, 2013) However, that technology can only become usefully adopted if and when the POR reaches the Operations and Support phase, usually years later.

Any information processing capability developed for the Defense enterprise must undergo a Certification and Accreditation (C&A)<sup>1</sup> process for Information Assurance (IA) before it can be made operational. C&A is the purview of the Designated Approving Authority (DAA) associated with the device, system, and/or environment of interest. C&A is a largely non-standard process that occurs prior to “Operations and Support” and typically takes more than a year to complete for well-understood

<sup>1</sup> Per DoD Instruction 8510.01, dated 12 March 14, the term C&A will be replaced by “Assessment and Authorization “(AA) and the term DAA will be replaced by “Authorizing Official” (AO). Legacy terms are used here because they are still in common use.

technologies. For innovative or disruptive technologies, the process can take several years. C&A updates are required whenever significant tech refreshes occur across the lifecycle of the capability. If an IT-intensive systems is to remain relevant, it must undergo frequent tech refresh.

DoD officials recognize that the process described above is not optimized for information systems. Accordingly, the latest update to the DoD Acquisition System policy helpfully suggests streamlining the transition process for “Software Intensive” programs, and for “Accelerated Acquisition Programs.” The streamlining calls for executing multiple software builds between MS B and MS C. That means that the iterative software development activity is preceded by the legacy AoA and requirements development process prior to MS A, and followed by legacy operational testing and C&A that occurs after MS B. (Department of Defense (DoD), 2013) In other words, even in this streamlined version, software development is inserted in the middle of a paper-intensive, serial verification process, based on criteria originally developed for traditional hardware. (See figure: 4) Hence the DoD Acquisition System still does not lend itself to rapid incremental transition of new IT. (GAO, 2014)

Meanwhile, Defense acquisition policy recognizes that the process for post IOC lifecycle sustainment of a software-intensive capability requires continuous tech refresh. This requirement is relentlessly driven by the fact that the original hardware and software quickly become unavailable from the Original Equipment Manufacturer (OEM.) In other words “sustaining” IT really means continually improving it, as suggested by Moore’s Law, not just fixing it when it breaks. Therefore, the sustainment phase after IOC requires defining requirements, AoA, risk reduction, engineering & manufacturing development, T&E, and C&A – i.e., the same activities required before IOC!

However, in the sustainment phase O&M funds, rather than RDT&E or procurement funds, are generally used to execute these activities. Per the FAR, O&M funds must be executed in their budget year. They may not be used for research and development or major procurements. Typically, therefore, O&M funds used to sustain equipment are executed via contracts for COTS products and services. Accordingly, Defense acquisition policy for capability sustainment is essentially to apply commercial best practices. (DAU) Consistent with that policy, best commercial practice for tech refresh of information systems includes rapid, parallel iteration of the following processes:

- Continuous feedback to-from operational customers to evolve requirements in concert with evolving technology
- Objective, testable Measures of Effectiveness, Performance, and Suitability.
- Best-of-breed lifecycle supported, open standard, pre-approved, off-the-shelf capability
- Performance-test-based AoA and source selection for risk reduction

- Pre-negotiated, performance-based, contracts
- Streamlined C&A via re-use of previously developed artifacts

Note that government officials must manage all those O&M post-IOC tech refresh activities according to the same Federal Acquisition Regulation (FAR) that governs material development prior to IOC.

## Building Blocks for the Bridge

Per discussion above, Christensen's insight, and study of the many successful and failed transitional efforts suggests some universal patterns of success. The following general recommendations are based on those patterns.

The best first step for transitioning an invention is to quickly wrap it in a utility that makes life easier or cheaper for a specific customer group. Focus on making the application useful, not hyping the enabling technology.

Government furnished IP is a powerful catalyst for industrial innovation. The best practice is to deliberately "open source" government IP rights as "Government Furnished Equipment" (GFE) available broadly to industry. Require vendors who are paid to develop IP at government expense to employ appropriate licenses and data rights models to make this happen.

Industrial innovation is a powerful force multiplier for government acquisition objectives. The best practice is to incentivize COTS industry to satisfy government requirements with their generic product lines. Employ acquisition strategies that build with generic COTS components rather than develop specialized capabilities via "commercial standards".

Standards can be catalysts for tech transition, but only if they either already exist, or if they evolve from the bottom up following initial adoption. Top down efforts to mandate creation of standards in order to transition technology simply don't succeed. The best practice is to implement mature commercial open standards for interfaces between productized functional capabilities. Require new functional inventions to interface via those specified functioning open standards. In other words encourage creativity and production within functional "boxes" in the system design. Require compliance with the specified mature and already functioning standard interface "lines" between the functional boxes. If the newly invented functional capability becomes widely adopted, its standardization will follow. (See Figure: 3)

## Success Defined

Applying these concepts to a the Defense acquisition system leads to the following set of conditions that define successful tech transition:

- Owner of new capability is identified
- Funds are available to procure and sustain it
- Prototype new capability has been demonstrated to interface usefully to legacy architecture.
- New capability satisfies threshold operational, system, and process requirements
- Lifecycle support model, including government's IP rights, is specified
- Capability is certified and accredited for functionality, safety, interoperability, and security
- Funding authority approves allocation of funds
- Convenient contract vehicle exists and governs lifecycle activities of capability
- Capability delivered and functions to threshold level in target environment
- Capability successfully undergoes lifecycle support

Historically, the government has achieved these conditions, intentionally or unintentionally, through one of these three approaches:

- Government procurement of purely commercial offerings
- Government-industry partnerships for tech transition via deliberate commercialization
- Government acquisition programs designed to develop government-specific capability

These options are listed in order of the Government's preference, i.e. as previously explained, laws and regulations mandate that government procurement should support and not compete with commercial industry. (US Federal Government)

## **The Bridge Design: Product Line Architecture**

Product Line Architecture (PLA) is a disruptive invention that helped transform the WWW, as well as other communications platforms, into the rapidly evolving commercial ecosystem they have become. PLA is the set of IT design characteristic and implementation processes at the intersection of an enterprise's e-business model, and its open standard IT platform. PLA aims to optimize the latter to achieve the former. Both Mac and Windows, for example, apply PLA very effectively within their respective IT device product lines. A body of work by Carnegie Mellon University (CMU) Software Engineering Institute (SEI) thoroughly explains and describes PLA in context with multiple real world use cases. (CMU SEI)

PLA imposes the discipline necessary to prevent the “verticals,” i.e. the product providers, in an enterprise from competing with each other on the basis of proprietary “horizontal” infrastructure. Correspondingly, PLA provides consumers with a single point of access to the entire suite of e-products provisioned by the enterprise of interest. PLA thus supports rapid speed-to-capability for initial capability, lifecycle refresh, and extending the scope of capability. It also enables decreased cost-per-capability through simplified integration and reuse of existing capabilities.

Although the term PLA has often been associated with relatively narrowly defined enterprise software frameworks such as Mac or Windows, or telecommunications platforms such as Nokia, the same concept can be applied more abstractly to more loosely defined and more federated Enterprise Information Systems (EIS). Arguably, for example, the eFile standards and policies governed by the Internal Revenue Service (IRS) represent a PLA of sorts. In any case, PLA is a disruptive invention designed to accelerate the transition of disruptive software inventions. For example, TurboTax represents a technology that transitioned via the IRS’s eFile PLA, and profoundly disrupted the tax filing and collecting ecosystem.

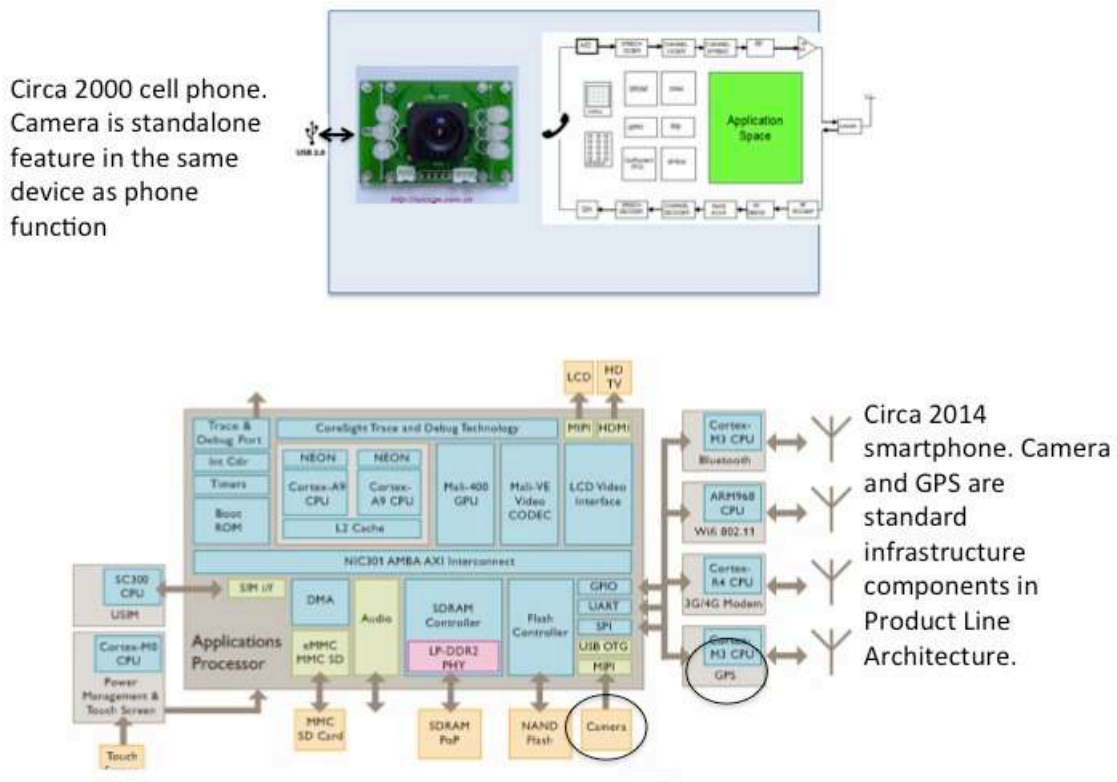

Figure 3: Product Line Architecture provides a platform to transition inventions immediately to adoption. Successful new components often evolve to become elements of infrastructure

Clearly the digital camera is a disruptive technology. Much of its disruptive influence was manifested when the camera-as-a-component was incorporated into PLA for IT devices like smart phones and tablets. The camera in an IT device consumes standard power, and transmits standard digital image data, via specified standard interfaces, according to a pre-negotiated standard intellectual property rights model, business model, security model, and lifecycle support models. All the downstream innovations that consume the standard digital image, e.g. instant messaging, Facetime, etc., are constrained on the back end, and accelerated to market on the front end, by the same PLA. Significantly, much of the disruptive influence of the Defense-developed, Global Positioning System (GPS) was manifested via the same, purely commercial, process.

Achieving the potentially catalytic benefits of PLA requires provisioning a suite of PLA-derived tools and processes to developers. The PLA suite's aim is to streamline and parallelize the myriad activities associated with transitioning IT inventions into operations. Here are some of those PLA utilities for rapid, iterative, parallel developing, testing, certifying, offering, consuming, and refreshing capability:

- Bottom up process, informed by customer-in-the-loop, for continuously adapting emerging standards against enterprise functional and performance specifications.
- Persistent, open, online "plug test" PLA Reference Implementation (RI) for developing, testing, and certifying inventions. Includes an evolving library of documented PLA-compliant components, developers' guides, and Software Development Kits (SDK).
- Certification requirements for security and interoperability are embedded in the technical guidance and the RI so that successfully compiled offerings inherit certification controls from the enterprise framework itself.
- Pre-negotiated contractual vehicles that address compensation and obligations to all parties, including intellectual property rights.

Note that Apple, Microsoft, Google, Android, etc. provision these PLA utilities to a huge global community of potential innovators. They do that via convenient resources available through open standard developers' portals at Apps Stores and similar online venues. These enterprises thereby crowd source technology transition by exposing a convenient transition path to their enterprise product lines. That is, the PLA-based developers' portal makes typically difficult activities -- such as Analysis of Alternatives (AoA), prototyping, iterative development, test and evaluation, certification, production, delivery, and lifecycle support --relatively easy and inexpensive to perform.

This "apps-store" transition model lends itself uniquely to the highly abstract nature of software. Unlike any other product type, developers always deploy software knowing that it is flawed. Continually collecting and acting on user feedback to

rapidly fix and enhance the previous iteration mitigates the risk associated with “buggy” software releases. This paradigm greatly decreases the time and cost of “manufacturing development” that traditionally follows demonstrations and tests of hardware prototypes.

In this sense, the online PLA portal provides a virtual laboratory for developing the invention, and a channel to market to transition the innovation. When the invention functions properly in the lab, it can transition as a certified, lifecycle-sustained, product that can be immediately lucrative for both the provider and consumer. If the invention fails to be adopted, it fails fast and cheap, with feedback for the next try.

Not surprisingly, the PLA utilities enumerated above align very well with the COTS best practices that Defense acquisition policy suggests are appropriate for sustainment of software intensive capability explained previously. Further, procurement of COTS products and services as a means to satisfy government requirements is not only legal, the FAR explicitly favors that approach. Finally, the recently implemented “IT Box” option for Joint Capabilities Integration and Development System (JCIDS) prescribes a COTS-friendly software development process for some narrowly defined programs. (Joint Chiefs of Staff, 2012)

Both the RDT&E and Procurement funds executed prior to IOC may legally be used to contract with COTS providers, and to purchase COTS end items. (DoD, 2000) Again, the JCIDS IT Box guidance, which is applicable to some FAR-compliant Defense programs, is well aligned with the COTS PLA best practices. Therefore, there is no statutory barrier to using the COTS best practices mandated for post IOC lifecycle support for all development activities prior to IOC. Rather, the barrier is the arbitrary assumption that software development requirements for various classes of modern systems are fundamentally different from each other. Making arbitrary assumptions about requirements is not consistent with good systems engineering.

## **Einsteinien Action**

Einstein explained that the same thinking, people, and processes that created your problem are unlikely to solve it. His advice was to find a fundamentally different approach. The Defense enterprise has been working hard to bridge the IT transition gap for two decades, more or less. All the points raised above have been raised before. Indeed, dedicated people in the Defense enterprise have taken intelligent action consistent with these arguments. However, the implementation methodologies typically do not heed Einstein’s warning. That is, professionals in the Defense Enterprise clearly understand the desired to-be end state. They also understand the deficiencies associated with the as-is status quo. The issue has been trying to close the gap between the as-is and to-be by using the Pentagon processes

that created the deficiencies in the first place. The following recommendations embrace Einstein's advice by applying Christensen's principles for implementing disruptive inventions via PLA.

### Incentivize Open System Approach

For decades, Defense policy has mandated compliance with standards. The hope is that complying with standards will naturally lead to interoperability and associated efficiencies. However, complying with standards as an objective in and of itself has not led to the hoped-for interoperability or associated efficiencies. Likewise, implementing new technology because it is new is a failed strategy. In contrast, PLA specifies standards as boundary conditions. Technologies, new or otherwise, are implemented if and only if they measurably improve targeted business outcomes. In this way, compliance with enterprise PLA earns a metaphorical "Good Housekeeping Seal of Approval." The PLA "logo" becomes a lucrative market differentiator.

The Einsteinian paradigm shift is to implement open standard approaches (e.g. JIE, IC ITE, DI2E) within the broader business objectives of disciplined enterprise PLA. Certainly require that component solution providers comply with technical standards for interoperability. However, don't test only for standard compliance. Test also for functionality, and mission performance enhancement. Contractually provide for an online feedback loop with operational customers of the delivered capability. Provide a clear open IP policy agreement, and require that solution providers sign up. Demand clear explanation of the evolutionary lifecycle support processes associated with any approved solution. Develop, publish, and implement need-to-share security and/or privacy policies. Reward compliance with PLA standards and business agreements with PLA certification "logo." Associate the logo with front-end loaded license and contract agreements that represent convenient pre-negotiated approvals from contracting officers and certification authorities. Publish a catalog of logoed offerings and associated procurement vehicles.

### Measure the Right Things

"You get what you measure!" A basic tenant of effective management is to measure the things that matter, and react accordingly. Defense acquisition projects measure compliance in terms of paperwork submitted. They also measure "Earned Value" defined as "contractually required activities completed on time and schedule." The most successful commercial enterprises, by contrast, measure the time and cost of compliance in order to streamline compliance. They also measure the margin between cost and value in order to maximize return on investment.

The Einsteinian paradigm shift is to employ testable, system-level and process-level Measures of Performance (MOP) that are tightly coupled to operational-level



Measures of Effectiveness (MOP). These metrics should objectively define: capability outcome requirements, cost-per-capability, speed-to-capability, and predictability of cost, performance, and schedule. (Gunderson C. R., 2014) Establish baseline values and objective V&V techniques that assure that business objectives are properly represented by MOE. Rigorously verify that achieving improved MOP indeed leads to improving MOE. Build this V&V capability into an instrumented, persistent, PlugTest environment. (Gunderson & Minton, Rapid Evolutionary Acquisition: An In Progress Review of an Exemplar Pilot Initiative, 2011)

### Pay for the Right Things the Right Way

“You get what you pay for!” The government pays for things by contracting. Government contracting is usually rigid, expensive, and takes a long time in order to “reduce risk”. Risk is indeed low in the sense that contractors by and large comply with the requirements of their contracts, i.e. the government generally accepts contract deliverables. Nevertheless, the Defense acquisition process is not sufficiently successful when measured against enterprise goals and objectives. Therefore, by definition, Defense acquisition system contracts are not paying for the right things.

One Einsteinian paradigm shift is to use the value-based metrics described above as basis for EIS contract award and incentives. Use published project budgets, schedules, use cases including MOE, MOP, and associated test cases in lieu of traditional solicitations. Use an instrumented PLA Plug Test environment as the platform for V&V of compliance, functionality, and performance in lieu of review of written claims.

Another Einsteinian change is to employ rapid, adaptive, procurement vehicles. These vehicles should be pre-negotiated and allow flexible-award. The vehicle should allow closely aligned use of the same COTS software lifecycle processes for research, procurement, and tech refresh of capability. Employ the inherent innovative potential of Other Transaction Agreements (OTA) (Cassidy, Putsch, & Barclay, 2013), in lieu of, in combination with, and in order to evolve improved versions of, traditional contracts.

### Virtualize and Standardize Security

Security requirements have historically stymied efforts to both accelerate development of information systems, and establish interoperability across systems. In response, new Defense policies demand that security strategies address need-to-share data and resources in balance with the traditional need-to-protect. New policy also requires that the various C&A authorities agree to reciprocity of C&A artifacts across their respective domains. However, traditional security models are based on physical separation, sharing across boundaries creates vulnerability by

definition. Traditional security technologies are not standard, and tend to be tuned to the requirements of a particular stovepipe system. Modern IT architectures, e.g. cloud, are based on logical separation. However, traditional C&A arguments do not recognize logical separation. (Gunderson, 2014)

The Einsteinien paradigm shift is to convert security compliance from a necessary evil to a value added moneymaker. Use virtual technologies to establish assured logical separation within an open standard “security layer” of the enterprise PLA. Develop associated new C&A assurance arguments. Explain the parallels to traditional arguments that allow the technologies that are logically “above” the security layer to inherit the security controls provided by the logical separation. Start with low risk, but important use cases that have strong political support. Use the commercial IT marketplace to expose requirements, government-developed IP, and explanation of the opportunity to industry at large. Demonstrate improved capability-per-cost, and speed-to-capability possible via this dynamic, virtual approach.

### **Manage Tech Transition in a Brown Field**

A green field project is one that is not constrained by prior work. A brown field project recognizes that starting fresh is an unaffordable luxury. (Hopkins, 2008) Typically government acquisition efforts are framed within the soda straw defined by their stovepiped funding model. Accordingly they favor re-invention over reuse, i.e. a green field approach. Re-invention wastes time and resources. Reuse of familiar infrastructure catalyzes adoption of new inventions.

The Einsteinien paradigm shift is to contractually identify existing commercial and government computer networks and components as furnished infrastructure. Project management plans including incentives, risks, and test and C&A strategies should specifically address how the furnished resources will be measurably leveraged. These plans should explain, in particular, how the existing infrastructure will allow early and continuous deployment of incremental capability deliveries, pending delivery of significant infrastructure improvements.

### **Automate Design, Engineering Workflow, and Compliance**

The technical requirements, design constraints, and potential solution options for any kind information systems are likely to be highly redundant. Further, as explained above, use of existing computer network infrastructure should be included in any new information system development. Nevertheless, Defense EIS projects tend to start from scratch with respect to both designing, and documenting compliance of the design. For example, the serial, paperwork required by the Joint Capability Integration Development System (JCIDS) is highly redundant. Yet, each

new EIS program that enters the JCIDS process spends millions of dollars and takes years to reproduce it.

Meanwhile there are certainly tools for automating design, workflow, and compliance that have effectively streamlined those processes in other domains. For example Computer Assisted Design (CAD) has vastly decreased the architecting and engineering time and cost of various classes of systems. TurboTax and similar tools have vastly decreased time and cost of complying with complex tax code, while maximizing the business objectives of the filer.

The Einsteinian paradigm shift is to apply the TurboTax and CAD paradigm and enabling technologies to develop expert systems that automate and streamline the Defense acquisition system. Expert systems like TurboTax puts detailed compliance requirements “under the hood.” CAD likewise puts details of technical standards, design constraints, and available solutions under-the-hood. User-friendly menus narrow the options. Semantic algorithms front-end-load the options that are most likely to be the most beneficial. The expert system “learns” over time. Automated workflow tools can distribute these functions across work centers.

Similar technology can provide similar automated expert assistance for engineering OEIS, while complying with JCIDS in the process. For example, the Marine Corps Combat Development Center demonstrated the viability of this methodology via the Semantically Informed, Dynamic Engineering of Capabilities and Requirements (SIDE CAR) prototype. (Lenet, et al., 2010.)

The latest Defense Acquisition System interim guidance takes a step in the right direction by recognizing the need to do iterative software development, but....

Upfront AoA and requirement V&V is still based on expensive, time consuming paperwork

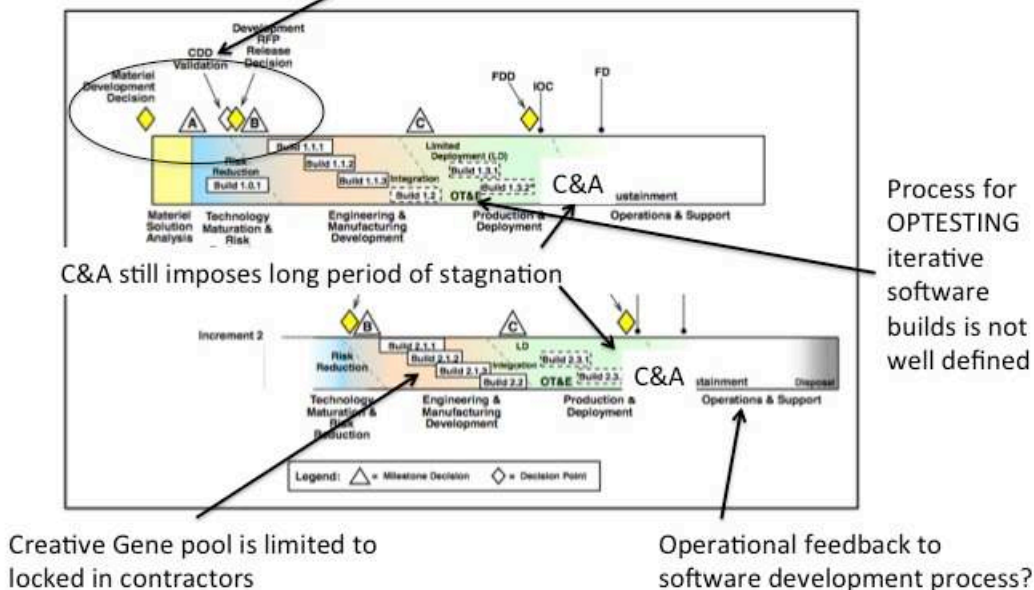

Figure 4: Diagram from 2013 interim guidance for Defense acquisition system (comments are the author's.) This approach inserts the "square peg" of iterative software development in the round hole of a traditional waterfall model

### Move from Monopoly to Market

Defense policy recognizes that IT, and software in particular, are critically important to virtually all material acquisitions. Nevertheless, efforts to improve Defense IT acquisition, rather arbitrarily, identify only certain categories of projects as appropriate for application of commercial best practices for IT. One implied assumption is that software development requirements for weapon or intelligence applications are fundamentally different than for financial or personnel applications. Another implied assumption is that the software requirements for Defense applications within one program are fundamentally different than software requirements for similar applications in other programs.

The basis for these assumptions is not clear. There are only so many ways to process data, and the zeroes and ones don't care why the data is being processed. Regardless, the software development requirements for a given Defense POR are addressed by the small monopoly and associated shallow creative gene pool represented by its locked-in Defense contractor team. Further, these software development requirements are addressed in the Defense acquisition serial process between milestones B and C. Hence, it is impossible for the isolated, time-boxed,

Defense acquisition software development process to keep up with the rapid evolution of IT in the rest of the world.

The rapid evolution of IT in the rest of the world is due largely to the massive crowd sourcing of global entrepreneurial creativity to business opportunities exposed in the COTS IT marketplace. Enterprises that expose a problem and a budget to the marketplace are rewarded with many inventive potential solutions from multiple sources, often in the form of already functioning inventions developed at the inventors' expense.

The Einsteinian paradigm shift is to abstract the software development component of Defense acquisition projects away from the serial waterfall acquisition process. Use the same, continuous, rapid, adaptive, software development process as a critical aspect of all phases of the Defense acquisition process, AoA, risk-reduction, development, production, test, certification, procurement, and life cycle tech refresh. Perform all these activities continuously in parallel across the lifecycle of a project.

Consider software development to be a critical enterprise concern across all Defense investments. That is, the software development requirements for all Defense programs should be exposed to the same marketplace. Don't make arbitrary distinctions based on category of system. Requirements are requirements. Even if a weapon system's requirements at the digital level actually are different than a business system's requirements, the marketplace is still the best way to address them.

Leverage competition and economy of scale by incentivizing a Defense IT marketplace that is literally a subset of the broad global IT marketplace. The Defense Enterprise often attempts to replicate commercial processes rather than join them. However, creating a relatively small duplicate of some aspect of a huge global market is not the same thing as staking out a claim within the huge global market. Economy of scale is absent in the small duplicate.

Catalyze this Defense IT sub-market by exposing use cases, MOP, MOE, test cases, standards, and especially budgets associated with all Defense information processing requirements. The approach to metrics, contracting, and process automation described above is part and parcel. Likewise, a persistent Defense enterprise PLA PlugTest environment, as explained above, can serve as a channel between this marketplace and Defense project offices. (Gunderson C. , 2014)

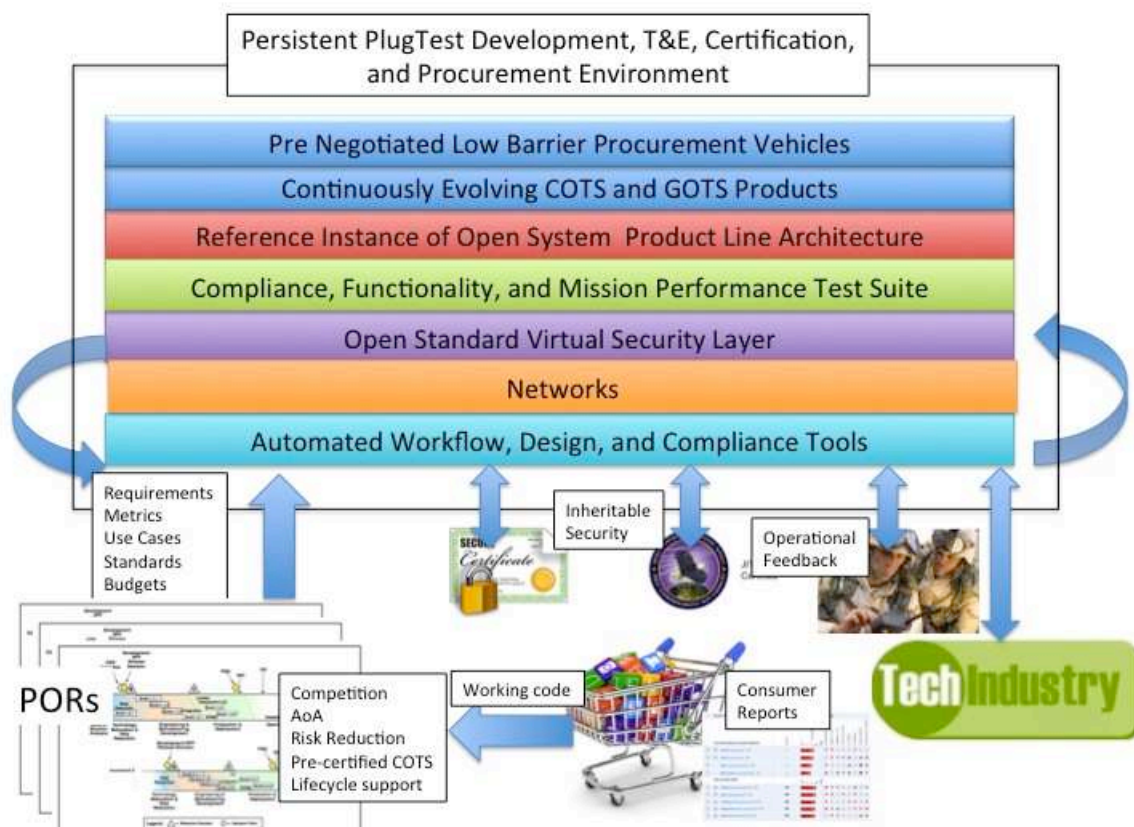

Figure 5: Conceptual model for using the COTS IT marketplace, and Defense enterprise PLA, to hold competition, perform AoA, do risk mitigating prototyping, pre-certifying useful components, and conveniently procuring lifecycle supported capability to programs across the Defense acquisition portfolio.

## Works Cited

- Cassidy, S. B., Putsch, J., & Barclay, S. B. (2013). Another Option in a Tightening Budget: A Primer on DoD "Other Transactions" Agreements . *The Procurement Lawyer* , 48 (3), 3-11.
- Christensen, C. (2003). *The Innovator's Dilemma: When New Technologies Cause Great Firms to Fail*. New York, New York, USA: Harper Collins.
- CMU SEI. (n.d.). *A Framework for Software Product Line Practice, Ver 5.0*. Retrieved July 14, 2014, from Software Engineering Institute, Carnegie Mellon University: [http://www.sei.cmu.edu/productlines/frame\\_report/index.html](http://www.sei.cmu.edu/productlines/frame_report/index.html)
- DAU. (n.d.). *DAG Chapter 5: Lifecycle Logistics*. (D. A. University, Producer) Retrieved July 12, 2014, from Defense Acquisition Guide: <https://acc.dau.mil/CommunityBrowser.aspx?id=489744&lang=en-US>
- Defense Science Board. (2009). *DoD Policy and Procedures for the Acquisition of Information Technology*. Washington DC: OUSD AT&L.
- Department of Defense (DoD). (2013, November 25). DoD Interim Instruction 5000.02: Operation of the Defense Acquisition System. Washington, DC: USD AT&L.

Department of Defense. (2009 ). *Department of Defense Reliability, Availability, and Maintainability and Cost Rationale Report Manual*. Washington DC: Office of the Secretary of Defense.

Department of Defense. (2014). *Performance of the Defense Acquisition System 2014 Annual Report*. Undersecretary of Defense for Acquisition, Technology, and Logistics. Washington, DC: DoD.

DoD. (2000, June). DoD Financial Management Regulation, Voume 2A. *DoD Financial Management Regulation , 2A Chapt 1 paragraph 01208* , 1-19. Washington, DC, USA.

GAO. (2014). *Information Technology: Agencies Need to Establish and Implement Incremental Development Policies* . Washington, DC: Government Accounting Office.

GAO. (2014). *Major Automated Information Systems: Selected Defense Programs Need to Implement Key Acquisition Practies*. Washington DC: GAO.

GAO. (2006). *Stronger Practices Needed to Improve DOD Technology Transition Processes*. Washington, DC: Government Accounting Office.

Gunderson, C. (2014). *Cloud Friendly Virtual Information Assurnace and Cross Domain Services*. NPS, Information Science. Monterey, CA: NPS.

Gunderson, C. (2014). *PLUGFEST: Demonstrating Agile Enterprise Information System Acquisition*. NPS, Information Science. Monterey, CA: Naval Postgraduate School.

Gunderson, C. R. (2014). *Sustainment and Net-ready Key Performance Parameters (KPP) in an Enterprise Information System (EIS) Value Assurance Framework (VAF)*. Naval Postgraduate School, Information Science. Monterey, CA: NPS.

Gunderson, C., & Minton, D. (2011). Rapid Evolutionary Acquisition: An In Progress Review of an Exemplar Pilot Initiative. *IEEE AWG SoSEE*. Albuquerque, NM: IEEE.

Hopkins, R. a. (2008). *Eating the IT Elephant: From Brownfield to Greenfield Development*. International Business Machines Press.

Joint Chiefs of Staff. (2012, January 19). Joint Capability Integration Development System Manual. Washington, DC, USA: JCS.

Lenet, D., Rode, B., Winant, N. K., Collins, S., Mayo, D., Berg-Cross, G., et al. (2010). *SIDECAR: Semantically Informed, Dynamic Engineering of Capabilities and Requirements*. Marine Corps Combat Development Center , Intelligence Integration Division. Auston, TX: Cycorp.

National Research Council. (2004). *Accelerating Technology Transition: Bridging the Valley of Death for Materials and Processes in Defense Systems*. NRC, National Materials Advisory Board, Board on Manufacturing and Engineering Design, Division on Engineering and Physical Sciences. Washington, DC: National Academy of Sciences.

Office of the Secretary of Defense. (2010). *A New Approach for Delivering Information Technology Capabilities in the Department of Defense*. Washington, DC: OSD.

Powner, D. A. (2014). *Reform initiatives Can Help Improve Efficiency and Effectiveness*. Government Accounting Office, Information Technology Mangement Issues. Washington, DC: GAO.

Russell, A. L. (2013, July 30). *OSI: The Internet that Wasn't*. Retrieved July 18, 2014, from IEEE Spectrum: <http://spectrum.ieee.org/computing/networks/osi-the-internet-that-wasnt>

United Nations Office on Drugs and Crime. (2012). *Use of the Internet for Terrorist Purposes*. United Nations, Office on Drugs and Crime. New York, NY: United Nations.

US Federal Government. (n.d.). *Acquisition Central: Federal Acquisition Regulation (FAR), Part 12 and 27*. Retrieved Jul 12, 2014, from [www.acquisition.gov](http://www.acquisition.gov): <http://www.acquisition.gov/far/>

US GAO. (2013). *Technology Transition Programs Support Military Users, but Opportunities Exist to Improve Measurement of Outcomes*. Government Accounting Office. Washington, DC: GAO.