



USER MANUAL

IPO2 Base Unit Experiment

Set Up and Configuration



© 2012 Quanser Inc., All rights reserved.

Quanser Inc.
119 Spy Court
Markham, Ontario
L3R 5H6
Canada
info@quanser.com
Phone: 1-905-940-3575
Fax: 1-905-940-3576

Printed in Markham, Ontario.

For more information on the solutions Quanser Inc. offers, please visit the web site at:
<http://www.quanser.com>

This document and the software described in it are provided subject to a license agreement. Neither the software nor this document may be used or copied except as specified under the terms of that license agreement. All rights are reserved and no part may be reproduced, stored in a retrieval system or transmitted in any form or by any means, electronic, mechanical, photocopying, recording, or otherwise, without the prior written permission of Quanser Inc.

Waste Electrical and Electronic Equipment (WEEE)



This symbol indicates that waste products must be disposed of separately from municipal household waste, according to Directive 2002/96/EC of the European Parliament and the Council on waste electrical and electronic equipment (WEEE). All products at the end of their life cycle must be sent to a WEEE collection and recycling center. Proper WEEE disposal reduces the environmental impact and the risk to human health due to potentially hazardous substances used in such equipment. Your cooperation in proper WEEE disposal will contribute to the effective usage of natural resources. For information about the available collection and recycling scheme in a particular country, go to ni.com/citizenship/weee.

电子信息产品污染控制管理办法（中国 RoHS）



中国客户 National Instruments 符合中国电子信息产品中限制使用某些有害物质命令（RoHS）。
关于National Instruments 中国 RoHS合规性信息，请登录 ni.com/environment/rohs_china
(For information about China RoHS compliance, go to ni.com/environment/rohs_china)

CE Compliance

This product meets the essential requirements of applicable European Directives as follows:

- 2006/95/EC; Low-Voltage Directive (safety)
- 2004/108/EC; Electromagnetic Compatibility Directive (EMC)

CONTENTS

1	Presentation	4
1.1	Description	4
1.2	Linear Modules and Experiment Overview	4
2	IP02 Components	6
2.1	IP02 Component Nomenclature	6
2.2	Component Description	6
3	IP02 Specifications	8
4	Wiring Procedure	10
4.1	Cable Nomenclature	10
4.2	Typical Connections	11
5	Testing and Troubleshooting	13
5.1	Motor	13
5.2	Encoder	13
6	Technical Support	14
7	Maintenance	15
7.1	Reducing IP02 Pinion Wear	15
7.2	Replacing the IP02 Pinions	15

1 PRESENTATION

1.1 Description

The IP02 is a fundamental module for the linear motion experiments. It consists of a precisely machined solid aluminum cart driven by a high quality DC motor equipped with a planetary gearbox. The cart slides along a stainless steel shaft using linear bearings. The cart is driven via a rack and pinion mechanism as opposed to belts or wheels, in order to eliminate slippage, belt stretching and other undesirable effects. This ensures consistent and continuous traction.

A typical IP02 is depicted in Figure 1.1. The IP02 pendulum can suspend in front of the cart to perform self-erecting and gantry experiments. The IP02 cart position is sensed using a quadrature incremental encoder whose shaft meshes with the track via an additional pinion. The IP02 is also equipped with a rotary joint to which a free-swinging rod can be attached and suspended in front of the cart. This rod functions, in subsequent experiments, as an "inverted pendulum", but more precisely as a self-erecting inverted pendulum as well as a regular inverted pendulum. The angle of the rod inclination about the vertical axis is also measured using a quadrature incremental encoder and is therefore unlimited and continuous over the entire range of motion. The pendulum in itself is a module and can be mounted on or remove from the cart. Furthermore, in order to run the self-erecting experiment, the supplied extra mass needs to be attached to the cart, so that the swinging inertia of the pendulum does not lift the cart off the track.

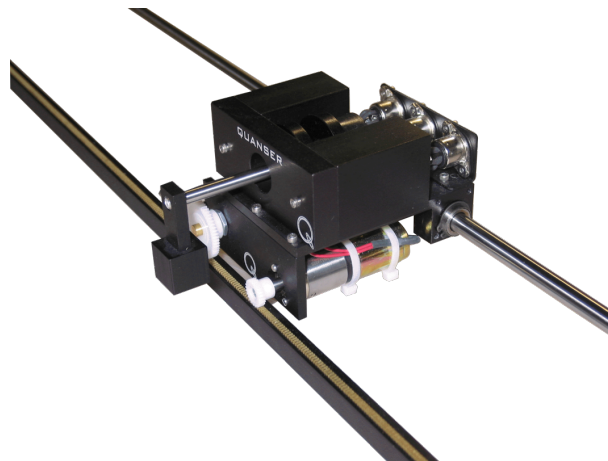

Figure 1.1: Quanser IP02 system

■ **Caution:** This equipment is designed to be used for educational and research purposes and is not intended for use by the general public. The user is responsible to ensure that the equipment will be used by technically qualified personnel only.

1.2 Linear Modules and Experiment Overview

The IP02 linear plant can be used stand-alone for several experiments, but it also serves as a base component for several add-on modules. Table 1.1 below lists these modules and the corresponding experiments that are supplied with them. Thus a new plant is obtained by adding a module which presents new modeling and control challenges.

System	Experiment	Description
IP02	IP02 QUARC Integration	Describes how to use the IP02 plant
IP02	Modeling	Derive the dynamic model of the IP02 from first-principles.
IP02	Position Control	Regulate position of the IP02 using PID.
IP02	Speed Control	Control the speed of the IP02 using a lead and lag compensator.
Single Pendulum Gantry	Anti-swing Control	Design of a control system to track a desired cart linear position while minimizing the swing of the suspended pendulum.
Single Inverted Pendulum	Inverted Pendulum Control	Model the system and then design a controller that balances the pendulum while the linear cart is tracking a reference position
Self-Erecting Single Inverted Pendulum	Self-Erecting Single Inverted Pendulum Control	Design a swing-up controller and a balance compensator to swing-up the pendulum from the resting downward position to the upright vertical position.
Single Linear Flexible Joint	Joint Deflection and Resonance Control	Model the system and design a control system to manipulate the position of a spring driven cart.
Seesaw	Seesaw Balance Control	Model the system and then design a controller that balances the seesaw using a sliding mass.
Seesaw with Single Linear Flexible Joint	Seesaw with Single Linear Flexible Joint Control	Design of a control system to balance a seesaw using a spring driven cart.
Seesaw and Inverted Pendulum	Seesaw with Inverted Pendulum Control	Design of a control system to balance an inverted pendulum on top of a seesaw.
Single Linear Flexible Joint with Inverted Pendulum	Single Linear Flexible Joint with Inverted Pendulum Control	Design of a control system to balance a pendulum on a spring driven cart.
Flexible Inverted Pendulum	Flexible Inverted Pendulum Control	Design of a control system to balance a flexible inverted pendulum.
Double Inverted Pendulum	Double Inverted Pendulum Control	Model the system and design a control system to balance a double inverted pendulum on a linear motion cart.

Table 1.1: IP02-based Experiments

2 IPO2 COMPONENTS

The IPO2 components are identified in Section 2.1. Some of those components are then described in Section 2.2.

2.1 IPO2 Component Nomenclature

The IPO2 components listed in Table 2.1 below are labeled in figures Figure 3.1a, Figure 3.1c, Figure 3.1b, Figure 3.1d, and Figure 3.1e.

ID	Component	ID	Component
1	IPO2 Cart	11	IPO2 Pendulum Encoder Connector
2	Stainless Steel Shaft	12	Motor Connector
3	Rack	13	DC Motor
4	Cart Position Pinion	14	Planetary Gearbox
5	Cart Motor Pinion	15	Linear Bearing
6	Cart Motor Pinion Shaft	16	Pendulum Socket
7	Pendulum Axis	17	IPO2 Weight
8	IPO2 Cart Encoder	18	Rack End Plate
9	IPO2 Pendulum Encoder	19	Rack Set Screw: (7/64)"
10	IPO2 Cart Encoder Connector	20	Track Discontinuity

Table 2.1: IPO2 Components

2.2 Component Description

2.2.1 DC Motor

The IPO2 utilizes a Faulhaber Coreless DC Motor (2338S006), as shown in Figure 3.1b and Figure 3.1c (component # 13). This model is a high-efficiency low-inductance motor resulting in a much faster response than a conventional DC motor. The complete specification sheet of the motor is included in [2].

■ **Caution:** *High-frequency signal applied to a motor will eventually damage the gearbox motor and the motor brushes.* The most likely source for high frequency noise is derivative feedback. If the derivative gain is set too high, a noisy voltage will be fed into the motor. To protect your motor, you should always band limit your signal (especially derivative feedback) to a value of 50 Hz.

■ **Caution:** Input ± 15 V, 3 A peak, 1 A continuous.

■ **Caution:** Exposed moving parts.

2.2.2 Planetary Gearbox

The IPO2 DC motor is coupled to a Faulhaber Planetary Gearhead Series 23/1, as shown in Figure 3.1b and Figure 3.1c (component # 14). Its reduction ratio is 3.71:1. The complete specification sheet of the planetary gearbox is included in [3].

2.2.3 Encoders

On the IP02, both cart and pendulum positions are measured with two optical encoders, represented in Figure 3.1a by components # 8 and 9, respectively. The encoder measuring the IP02 cart linear position does so through a rack-pinion system. Both encoders are typically identical. The encoder model used in the IP02 is a US Digital S1 single-ended optical shaft encoder. It offers a high resolution of 4096 counts per revolution (i.e. 1024 lines per revolution with two channels in quadrature). The complete specification sheet of the S1 optical shaft encoder is included in [1]. Remark that incremental encoders measure the relative angle of the shaft.

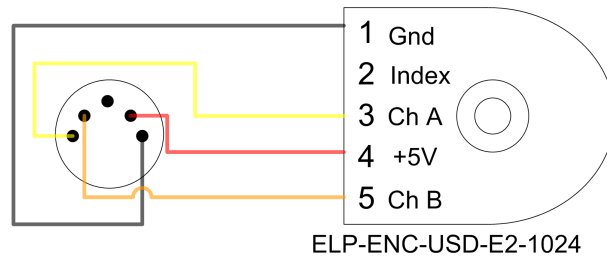

Figure 2.1: IP02 encoder wiring

The position signal generated by the encoder can be directly connected to the data-acquisition device using a standard 5-pin DIN cable. The internal wiring of the encoder and the 5-pin DIN connectors on the IP02, components #10 and #11, is illustrated in Figure 2.1.

■ **Caution:** Make sure you connect the encoder directly to your data-acquisition device and not to the power amplifier.

3 IPO2 SPECIFICATIONS

Table 3.1 lists and characterizes the main parameters associated with the IPO2. Some of these are used in the mathematical model.

Symbol	Description	Value	Variation
V_{nom}	Motor nominal input voltage	6.0 V	
R_m	Motor armature resistance	2.6 Ω	$\pm 12\%$
L_m	Motor armature inductance	0.18 mH	
k_t	Motor current-torque constant	7.68×10^{-3} N m/A	$\pm 12\%$
k_m	Motor back-emf constant	7.68×10^{-3} V/(rad/s)	$\pm 12\%$
η_m	Motor efficiency	0.69	$\pm 5\%$
$J_{m,rotor}$	Rotor moment of inertia	3.90×10^{-7} kg · m ²	$\pm 10\%$
K_g	Planetary gearbox gear ratio	3.71	
η_g	Planetary gearbox efficiency	0.90	$\pm 10\%$
M_c	Mass of cart	0.38 kg	
M_w	Mass of cart weight	0.37 kg	
$B_{eq,c}$	Equivalent viscous damping coefficient (Cart)	4.3 N m s/rad	
$B_{eq,c}$	Equivalent viscous damping coefficient (Cart and Weight)	5.4 N m s/rad	
L_t	Track length	0.990 m	
T_c	Cart travel	0.814 m	
P_r	Rack pitch	1.664×10^{-3} m/tooth	
r_{mp}	Motor pinion radius	6.35×10^{-3} m	
N_{mp}	Motor pinion number of teeth	24	
r_{pp}	Position pinion radius	0.01483 m	
N_{pp}	Position pinion number of teeth	56	
K_{ec}	Cart encoder resolution	2.275×10^{-5}	
K_{ep}	Pendulum encoder resolution	0.0015 rad/count	
f_{max}	Maximum input voltage frequency	50 Hz	
I_{max}	Maximum input current	1 A	
ω_{max}	Maximum motor speed	628.3 rad/s	

Table 3.1: IPO2 Specifications

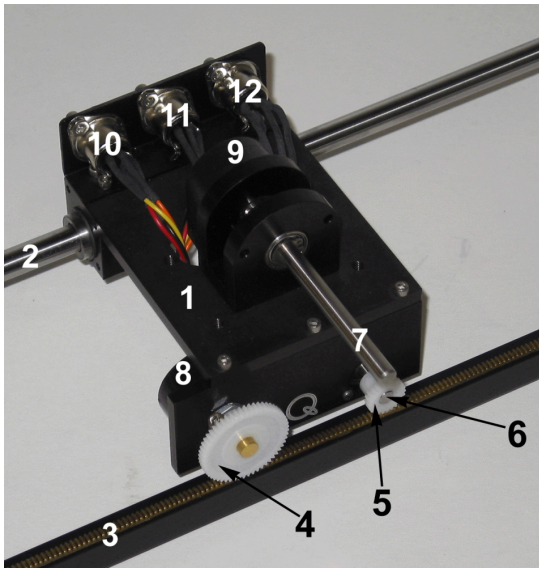

(a) Top view

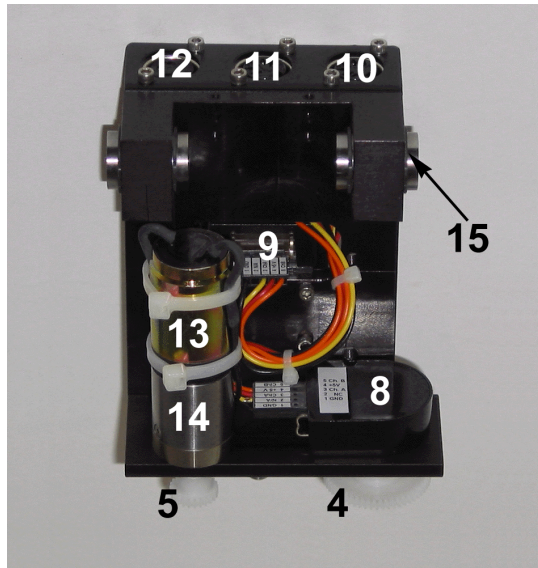

(b) Bottom view

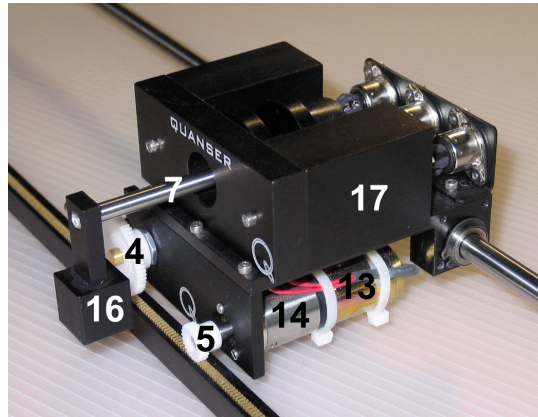

(c) Front view

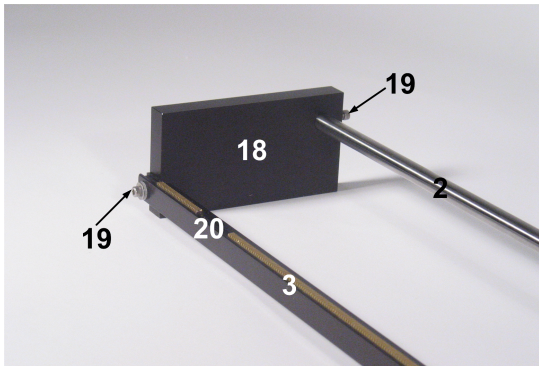

(d) Rack left end

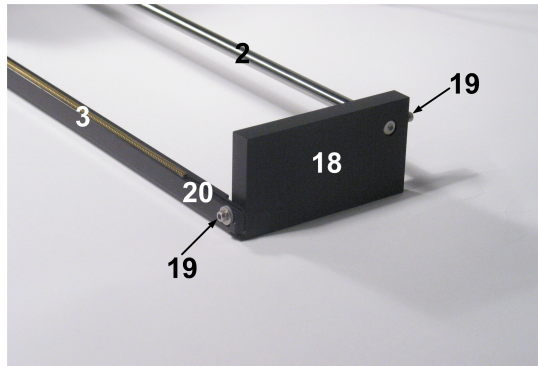

(e) Rack right end

Figure 3.1: IP02 components

4 WIRING PROCEDURE

The following is a listing of the hardware components used in this experiment:

1. **Power Amplifier:** Quanser VoltPAQ-X1, or equivalent.
2. **Data Acquisition Board:** Quanser Q1-cRIO, Q2-USB, Q8-USB, QPID/QPIDe, NI DAQ, or equivalent.

See the corresponding documentation for more information on these components. The cables supplied with the IP02 are described in Section Section 4.1 and the procedure to connect the above components is given in Section 4.2.

■ **Caution:** When using the Quanser VoltPAQ-X1 power amplifier, **make sure you set the Gain to 1!**

■ **Caution:** If the equipment is used in a manner not specified by the manufacturer, the protection provided by the equipment may be impaired.

4.1 Cable Nomenclature

The cables used to connect the Quanser IP02 system with a power amplifier and data-acquisition device is shown in Table 4.1. Depending on your configuration, not all these cables are necessary.



Cable	Type	Description
 <p>(a) RCA Cable</p>	2xRCA to 2xRCA	This cable connects an analog output of the data acquisition terminal board to the power module for proper power amplification.
 <p>(b) Motor Cable</p>	4-pin-DIN to 6-pin-DIN	This cable connects the output of the power module, after amplification, to the DC motor.
 <p>(c) Encoder Cable</p>	5-pin-stereo-DIN to 5-pin-stereo-DIN	This cable carries the encoder signals between an encoder connector and the data acquisition board (to the encoder counter). Namely, these signals are: +5 VDC power supply, ground, channel A, and channel B

Table 4.1: Cables used to connect IP02 to amplifier and DAQ device

4.2 Typical Connections

This section describes the typical connections used to connect the IP02 plant to a data-acquisition board and a power amplifier. The connections are described in detail in the procedure below, summarized in Table 4.2, and pictured in Figure 4.1.

Note: The wiring diagram shown in Figure 4.1 is using a generic data acquisition device. The same connections can be applied for any data-acquisition system that has at least 1x analog output, and 2x encoder inputs.

Cable	From	To	Signal
1	Terminal Board: Analog Output #0	Amplifier <i>Amplifier Command</i> connector	Control signal to the amplifier.
2	Amplifier: <i>To Load</i> connector	IP02 <i>Motor</i> connector	Power leads to the IP02 dc motor.
3	Terminal Board: Encoder Input #0	IP02 <i>Cart Encoder</i> connector	Cart encoder position measurement.
4	Terminal Board: Encoder Input #1	IP02 <i>Pendulum Encoder</i> connector	Pendulum encoder angle measurement.

Table 4.2: IP02 Wiring

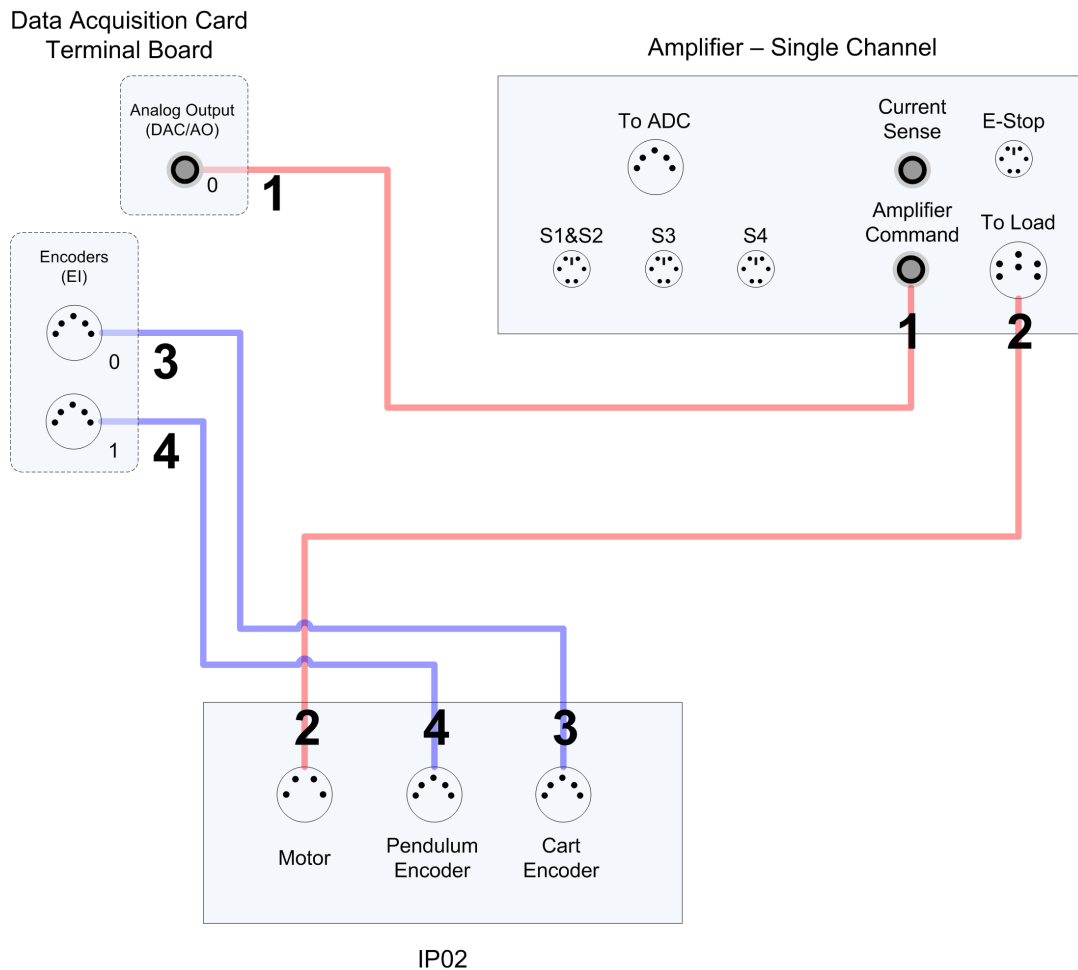

Figure 4.1: Connecting the IP02 to a Single-Channel Amplifier and Two-Channel DAQ

Follow these steps to connect the IP02 system:

1. Make sure that your data-acquisition device is installed and is operational. For example, if using the Quanser Q2-USB see Reference [5].
2. Make sure everything is powered off before making any of these connections. This includes turning off your PC and the amplifier.
3. Connect one end of the 2xRCA to 2xRCA cable from the Analog Output Channel #0 on the terminal board to the *Amplifier Command* connector on the amplifier, i.e. use both white or both red RCA connectors. See cable #1 shown in Figure 4.1. This carries the attenuated motor voltage control signal, V_m/K_a , where K_a is the amplifier gain.
4. Connect the 4-pin-stereo-DIN to 6-pin-stereo-DIN that is labeled from *To Load* on the amplifier to the *Motor* connector on the IP02. See connection #2 shown in Figure 4.1. The cable transmits the amplified voltage that is applied to the SRV02 motor and is denoted V_m .
5. Connect the 5-pin-stereo-DIN to 5-pin-stereo-DIN cable from the *Cart Encoder* connector on the IP02 panel to Encoder Input # 0 on the terminal board, as depicted by connection #3 in Figure 4.1. This carries the cart position measurement.
6. Connect the 5-pin-stereo-DIN to 5-pin-stereo-DIN cable from the *Pendulum Encoder* connector on the IP02 panel to Encoder Input # 1 on the terminal board, as depicted by connection #4 in Figure 4.1. This carries the pendulum angle measurement.

■ **Caution:** Any encoder should be directly connected to the data-acquisition terminal board (or equivalent) using a standard 5-pin DIN cable. **DO NOT connect the encoder cable to the amplifier!**

5 TESTING AND TROUBLESHOOTING

This section describes some functional tests to determine if your IP02 is operating normally. It is assumed that the IP02 is connected as described in the Section 4, above. To carry out these tests, it is preferable if the user can use a software such as **QUARC®** or **LabVIEW®** to read sensor measurements and feed voltages to the motor. See Reference [4] to learn how to interface the IP02 with QUARC. Alternatively, these tests can be performed with a signal generator and an oscilloscope.

5.1 Motor

5.1.1 Testing

Ensure the IP02 motor is operating correctly by going through this procedure:

1. Apply a small voltage to analog output channel #0 of the terminal board using, for example, the QUARC software.
2. The cart should move to the right when facing the IP02 (facing the motor pinions with the cables connected to the back).

5.1.2 Troubleshooting

If the motor is not responding to a voltage signal, go through these steps:

- Verify that the power amplifier is functional. For example when using the Quanser VoltPAQ device, is the green LED lit?
- Check that the data-acquisition board is functional, e.g. ensure it is properly connected, that the fuse is not burnt.
- Make sure the voltage is actually reaching the motor terminals (use a voltmeter or oscilloscope).
- If the motor terminals are receiving the signal and the motor is still not turning, your motor might be damaged and will need to be repaired. Please see Section 6 for information on contacting Quanser for technical support.

5.2 Encoder

5.2.1 Testing

Follow this procedure to test the IP02 encoders:

1. Measure Encoder Input Channel #0 using, for instance, the QUARC software.
2. Move the IP02 cart towards the right side of the track. This movement should result in a positive change in the cart position encoder counts at a rate of +4096 counts per revolution.
3. Similarly, rotating the IP02 free-falling pendulum (or pendulum socket) counter-clockwise, when facing the cart, should result in a positive change in the pendulum encoder counts at a rate of +4096 counts per rotation.

Note: Some data acquisition systems do not measure in quadrature and, in this case, one-quarter of the expected counts are received. In addition, some data acquisition systems measure in quadrature but increment the count by 0.25 (as opposed to having an integer number of counts). Make sure the details of the data-acquisition system being used is known. The counters on the Quanser DAQ boards measure in quadrature and therefore a total of four times the number of encoder lines per rotation, e.g. a 1024-line encoder results in 4096 integer counts for every full rotation.

5.2.2 Troubleshooting

If the encoder is not measuring properly, go through this procedure:

- Check that the data-acquisition board is functional, e.g. ensure it is properly connected, that the fuse is not burnt.
- Check that both the A and B channels from the encoder are properly generated and fed to the data-acquisition device. Using an oscilloscope, there should be two square waves, signals A and B, with a phase shift of 90 degrees. If this is not observed then the encoder may be damaged and need to be replaced. Please see Section 6 for information on contacting Quanser for technical support.

6 TECHNICAL SUPPORT

To obtain support from Quanser, go to <http://www.quanser.com/> and click on the Tech Support link. Fill in the form with all the requested software and hardware information as well as a description of the problem encountered. Also, make sure your e-mail address and telephone number are included. Submit the form and a technical support person will contact you.

7 MAINTENANCE

7.1 Reducing IPO2 Pinion Wear

The motor and encoder pinions will wear gradually over time as a result of regular use. If the motor pinion is wearing or becoming damaged prematurely, consult the following checklist to improve the lifetime of the pinions:

1. Ensure that the track is firmly clamped to a flat surface. The following procedure should be followed when clamping the track to a table:
 - (a) Loosen the track set screws located at either end of the track (Component #19 in Figure 3.1d and Figure 3.1e).
 - (b) Clamp one side of the track to the tabletop.
 - (c) Tighten the track set screw furthest away from the clamp.
 - (d) With the track flat and balanced, tighten the track set screw closest to the clamp.

Note: If necessary, two clamps can be used on either side of the track to ensure that the track remains straight and does not move when is use.

2. Check that the track support, shown in Figure 7.1, is located in the centre of the track

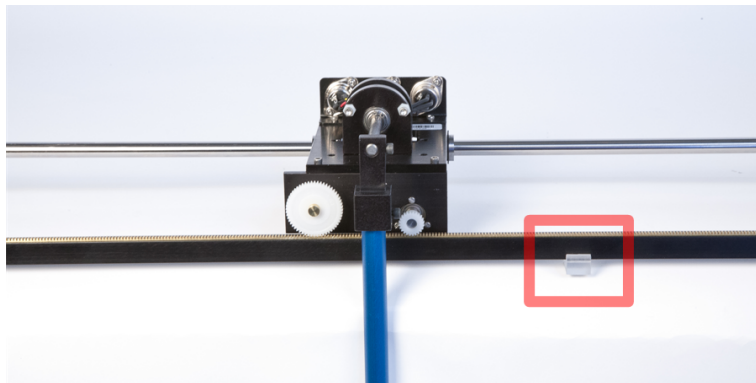

Figure 7.1: IP02 track support

3. Check that the pinions for both the endoder and the motor are aligned in the centre of the rack.

7.2 Replacing the IPO2 Pinions

The IP02 comes with several replacement motor and encoder pinions. If you require additional units, contact your local distributor for information on purchasing replacement component kits for the IP02.

Motor Pinion

To replace the motor pinion, slide the damaged pinion off of the motor shaft. You can also use a screwdriver to gain additional leverage, but be careful not to damage the IP02 cart while removing the pinion. We recommend using a Track-Brad-Staple Puller (McMaster-Carr #5865A11) with some additional padding to prevent damage to the cart, as shown in Figure 7.2.



Figure 7.2: Pinion removal tool

Encoder Pinion

The encoder pinion can be removed by loosening the set screw located on the pinion, and sliding the pinion off the encoder shaft by hand.

Note: Make sure to adjust the motor and encoder pinions to ensure that they are located in the centre of the rack. This will prevent uneven wear on the pinions.

REFERENCES

- [1] US Digital. *E2 Optical Kit Encoder*, 2007.
- [2] Faulhaber. *DC-Micromotors Series 2338*, 2002.
- [3] Faulhaber. *Planetary Gearhead Series 23/1*, 2002.
- [4] Quanser Inc. *IP02 QUARC Integration*, 2008.
- [5] Quanser Inc. *Q2-USB Data-Acquisition System User's Guide*, 2010.

Nine linear motion plants for teaching fundamental and advanced controls concepts



Quanser's linear collection allows you to create experiments of varying complexity – from basic to advanced. With nine plants to choose from, students can be exposed to a wide range of topics relating to mechanical and aerospace engineering. For more information please contact info@quanser.com

©2012 Quanser Inc. All rights reserved.



INFO@QUANSER.COM

+1-905-940-3575

QUANSER.COM

Solutions for teaching and research. Made in Canada.