



# NAVAL POSTGRADUATE SCHOOL

MONTEREY, CALIFORNIA

## **Littoral Undersea Warfare in 2025**

by

CDR Victor Bindi	LCDR Michael Kaslik
LT Jeffrey Baker	LT Keith Manning
LT Ryan Billington	LT Peter Marion
LT Tawanna Gallassero	LT Arthur Mueller
LT Joseph Gueary	LT Nathan Scherry
LT Justin Harts	LT John Strunk

December 2005

**Approved for public release; distribution is unlimited.**

Prepared for: Deputy Chief of Naval Operations for Warfare  
Requirements and Programs (OPNAV N7), 2000 Navy  
Pentagon, Rm. 4E392, Washington, DC 20350-2000

THIS PAGE INTENTIONALLY LEFT BLANK

<b>REPORT DOCUMENTATION PAGE</b>			<i>Form Approved OMB No. 0704-0188</i>	
Public reporting burden for this collection of information is estimated to average 1 hour per response, including the time for reviewing instruction, searching existing data sources, gathering and maintaining the data needed, and completing and reviewing the collection of information. Send comments regarding this burden estimate or any other aspect of this collection of information, including suggestions for reducing this burden, to Washington Headquarters Services, Directorate for Information Operations and Reports, 1215 Jefferson Davis Highway, Suite 1204, Arlington, VA 22202-4302, and to the Office of Management and Budget, Paperwork Reduction Project (0704-0188) Washington, DC 20503.				
<b>1. AGENCY USE ONLY (Leave blank)</b>		<b>2. REPORT DATE</b> December 2005	<b>3. REPORT TYPE AND DATES COVERED</b> Thesis Technical Report	
<b>4. TITLE AND SUBTITLE</b> Littoral Undersea Warfare in 2025			<b>5. FUNDING NUMBERS</b>	
<b>6. AUTHOR(S)</b> CDR Victor Bindi, LCDR Michael Kaslik, LT Jeffrey Baker, LT Keith Manning, LT Ryan Billington, LT Peter Marion, LT Tawanna Gallassero, LT Arthur Mueller, LT Joseph Gueary, LT Nathan Scherry, LT Justin Harts, LT John Strunk				
<b>7. PERFORMING ORGANIZATION NAME(S) AND ADDRESS(ES)</b> Naval Postgraduate School Monterey, CA 93943-5000			<b>8. PERFORMING ORGANIZATION REPORT NUMBER</b> NPS-97-06-001	
<b>9. SPONSORING / MONITORING AGENCY NAME(S) AND ADDRESS(ES)</b> Deputy Chief of Naval Operations for Warfare Requirements and Programs (OPNAV N7), 2000 Navy Pentagon, Rm. 4E392, Washington, DC 20350-2000			<b>10. SPONSORING / MONITORING AGENCY REPORT NUMBER</b>	
<b>11. SUPPLEMENTARY NOTES</b> The views expressed in this thesis are those of the author and do not reflect the official policy or position of the Department of Defense or the U.S. Government.				
<b>12a. DISTRIBUTION / AVAILABILITY STATEMENT</b> Approved for public release; distribution is unlimited.			<b>12b. DISTRIBUTION CODE</b> A	
<b>13. ABSTRACT (maximum 200 words)</b> The US Navy is unlikely to encounter a sea-borne peer competitor in the next twenty years. However, some regional powers will seek to develop submarine forces which could pose a significant threat in littoral waters. In this context, the <i>Littoral Anti-Submarine Warfare (ASW) in 2025 Project</i> applied Systems Engineering principles and processes to create a number of competing ASW force architectures capable of neutralizing the enemy submarine threat. Forces composed of distributed unmanned systems and projected conventional ASW force systems were modeled and analyzed. Results provided insight to ASW challenges and suggested continued efforts that are required to further define and integrate the contribution of evolving technologies into the complex undersea battlespace.				
<b>14. SUBJECT TERMS</b> Anti-Submarine Warfare, Littoral Warfare, Unmanned Systems, Systems Engineering			<b>15. NUMBER OF PAGES</b> 440	
			<b>16. PRICE CODE</b>	
<b>17. SECURITY CLASSIFICATION OF REPORT</b> Unclassified	<b>18. SECURITY CLASSIFICATION OF THIS PAGE</b> Unclassified	<b>19. SECURITY CLASSIFICATION OF ABSTRACT</b> Unclassified	<b>20. LIMITATION OF ABSTRACT</b> UL	

THIS PAGE INTENTIONALLY LEFT BLANK

**NAVAL POSTGRADUATE SCHOOL  
MONTEREY, CA 93943-5001**

RDML Patrick W. Dunne, USN  
President

Richard Elster  
Provost

This report was prepared for the Deputy Chief of Naval Operations for Warfare Requirements and Programs (OPNAV N7), 2000 Navy Pentagon, Rm. 4E392, Washington, DC 20350-2000.

Reproduction of all or part of this report is not authorized without permission of the Naval Postgraduate School.

This report was prepared by Systems Engineering and Analysis Cohort Eight (SEA-8):

CDR Victor Bindi  
LT Jeffrey Baker  
LT Ryan Billington  
LT Tawanna Gallassero  
LT Joseph Gueary  
LT Justin Harts

LCDR Michael Kaslik  
LT Keith Manning  
LT Peter Horton  
LT Arthur Mueller  
LT Nathan Scherry  
LT John Strunk

Reviewed by:

---

FRANK SHOUP, Ph.D.  
SEA-8 Project Advisor  
Littoral Undersea Warfare in 2025

---

ROGER BACON, VADM, USN (Ret.)  
SEA-8 Project Advisor  
Littoral Undersea Warfare in 2025

---

FRANK SHOUP, Ph.D.  
Director for Education  
Wayne E. Meyer Institute of  
Systems Engineering

---

LEONARD A. FERRARI, Ph.D.  
Associate Provost and Dean of Research

THIS PAGE INTENTIONALLY LEFT BLANK

## ABSTRACT

The US Navy is unlikely to encounter a sea-borne peer competitor in the next twenty years. However, some regional powers will seek to develop submarine forces which could pose a significant threat in littoral waters. In this context, the *Littoral Anti-Submarine Warfare (ASW) in 2025 Project* applied Systems Engineering principles and processes to create a number of competing ASW force architectures capable of neutralizing the enemy submarine threat. Forces composed of distributed unmanned systems and projected conventional ASW force systems were modeled and analyzed. Results provided insight to ASW challenges and suggested continued efforts that are required to further define and integrate the contribution of evolving technologies into the complex undersea battlespace.

THIS PAGE INTENTIONALLY LEFT BLANK



## TABLE OF CONTENTS

ABSTRACT.....	v
TABLE OF CONTENTS.....	vii
LIST OF FIGURES.....	ix
LIST OF TABLES.....	xi
LIST OF SYMBOLS, ACRONYMS AND/OR ABBREVIATIONS.....	xiii
EXECUTIVE SUMMARY.....	xvii
ACKNOWLEDGEMENT.....	xix
1.0 INTRODUCTION.....	1
1.1 PURPOSE.....	1
1.2 TASKING.....	1
1.3 SYSTEM ENGINEERING METHODOLOGY.....	2
1.4 SCENARIO.....	8
2.0 PROBLEM DEFINITION.....	10
2.1 NEEDS ANALYSIS.....	10
2.1.1 Introduction and Concept Development.....	10
2.1.2 Understanding Anti-Submarine Warfare.....	10
2.1.2.1 Understanding the Littoral.....	15
2.1.2.2 Defining Littoral for the “ASW in the Littorals” Problem.....	16
2.1.2.3 Understanding Littoral ASW.....	17
2.1.2.4 Understanding ASW Operations in the 21st Century.....	19
2.1.3 Primitive Need.....	21
2.1.4 System Decomposition.....	22
2.1.4.1 Function.....	24
2.1.4.2 Components.....	24
2.1.4.3 Hierarchical Structure.....	31
2.1.4.4 State.....	33
2.1.5 Stakeholder Analysis.....	36
2.1.5 Input-Output Modeling.....	39
2.1.7 Effective Need.....	41
2.1.8 Functional Analysis.....	41
2.1.8.1 Command Functional Analysis.....	43
2.1.8.2 Deploy Functional Analysis.....	45
2.1.8.3 Prosecution Functional Analysis.....	47
2.1.8.4 Defeat Functional Analysis.....	48
2.1.8.5 Functional Flow.....	49
2.1.8.6 Operating Concept.....	50
2.1.9 FUTURES ANALYSIS.....	53
2.1.9.1 Past, Present, and Future ASW Strategy.....	53
2.1.9.2 Futures Analysis From a C4ISR Perspective.....	58
2.1.9.3 False Assumptions for the Future.....	62
2.1.9.4 Future Potential Threats.....	63
2.1.9.5 Closing the Future Capabilities Gap.....	64
2.2 REQUIREMENTS GENERATION.....	67
2.2.1 Requirements for Deployment.....	68

2.2.1.1	System Component Requirements for Prepare .....	68
2.2.1.2	System Component Requirements for Deliver .....	68
2.2.1.3	System Component Requirements for Sustainment .....	69
2.2.2	Requirements for Prosecution .....	69
2.2.2.1	Assess .....	70
2.2.2.2	Detection .....	71
2.2.2.3	Tracking .....	72
2.2.2.4	Classification .....	72
2.2.3	Requirements for PDT (Defeat) .....	74
2.2.3.1	Maneuver .....	74
2.2.3.2	Deter .....	75
2.2.3.3	Engage .....	75
2.2.3.4	Stakeholder Interoperability and Compatibility Platform Requirements 75	
2.2.4	Requirements for Command .....	77
2.2.4.1	Communicate .....	78
2.2.4.2	Network Data .....	79
2.2.4.4	Exchange ISR Data .....	82
2.3	OBJECTIVES ANALYSIS .....	82
2.3.1	Objectives Analysis for Command .....	84
2.3.1.1	Communicate .....	85
2.3.1.2	Network Data .....	86
2.3.1.3	Exchange ISR .....	87
2.3.2	Objectives Analysis for Deployment .....	88
2.3.2.1	Prepare .....	88
2.3.2.2	Deliver .....	88
2.3.2.3	Sustain .....	88
2.3.3	Objectives Analysis for Prosecute .....	89
2.3.3.1	Initial Discoveries .....	90
2.3.3.2	Objectives Hierarchy Matrices .....	91
2.3.3.3	Tying Requirements to Objectives .....	96
2.3.3.4	Assess .....	97
2.3.3.5	Search and Detect .....	100
2.3.3.6	Tracking .....	102
2.3.3.7	Classification .....	104
2.3.4	Objectives Analysis for Defeat .....	106
2.3.4.1	Maneuver .....	106
2.3.4.2	Deter .....	106
2.3.4.3	Engage .....	106
3.0	DESIGN AND ANALYSIS .....	108
3.1	ETHICS IN ANALYSIS .....	108
3.2	SCENARIO BUILDING .....	109
3.2.1	Very Constrained Scenario .....	111
3.2.2	Semiconstrained Scenario .....	112
3.2.3	Coastal Scenario .....	113
3.2.4	Anticipated Threats .....	115

3.2.4.1	Diesel-Powered Submarines .....	115
3.2.4.2	Nuclear-Powered Submarines .....	115
3.2.4.3	AIP Submarines .....	116
3.2.4.4	UUV Technology .....	116
3.3	ALTERNATIVES GENERATION .....	116
3.3.1	Command Alternatives Generation .....	117
3.3.1.1	C4ISR Design Space Analysis .....	117
3.3.1.2	C4ISR Network Architecture Alternatives .....	118
3.3.1.3	C4ISR Communications Architecture Alternatives .....	119
3.3.1.4	C4ISR Feasibility Screening .....	134
3.3.1.5	Feasibility Screening Matrix .....	141
3.3.2	Deployment Alternatives Generation .....	142
3.3.2.1	Preparation .....	143
3.3.2.2	Deliver .....	145
3.3.2.3	Sustain .....	148
3.3.3	Prosecution Alternatives Generation .....	149
3.3.3.1	Air- and Space-Based Sensors .....	152
3.3.3.2	Surface Sensors .....	161
3.3.3.3	Subsurface Sensors .....	167
3.3.4	PDT Alternatives Generation .....	172
3.3.4.1	Maneuver .....	172
3.3.4.2	Deter .....	174
3.3.4.3	Engage .....	174
3.3.5	ALTERNATIVE ARCHITECTURES .....	175
3.3.5.1	Alternative 1: Tripwire .....	175
3.3.5.2	Alternative 2: Sea TENTACLE, TSSE .....	177
3.3.5.3	Alternative 3: War of Machines .....	178
3.3.5.4	Alternative 4: LAG .....	181
3.3.5.5	Alternative 5: Floating Sensors .....	183
3.4	MODELING AND ANALYSIS .....	185
3.4.1	Command Modeling and Analysis .....	185
3.4.1.1	Undersea Acoustic Data Transfer Model .....	185
3.4.1.2	Above the Sea Data Transfer Model .....	193
3.4.2	Deployment Modeling .....	207
3.4.2.1	Introduction .....	207
3.4.2.2	Methodology .....	209
3.4.2.3	Research and Assumptions .....	209
3.4.2.4	Requirements and Objectives .....	218
3.4.2.5	Modeling of Alternatives .....	219
3.4.3	Prosecution Modeling .....	237
3.4.3.1	Assess .....	238
3.4.3.2	Search and Detection .....	247
3.4.3.3	Tracking .....	256
3.4.4	High Level Modeling: NSS .....	266
3.4.4.1	Introduction to Modeling With NSS .....	266
3.4.4.2	NSS Study Plan Development .....	276

4.0	RESULTS, INSIGHTS, AND CONCLUSIONS .....	281
4.1	INTRODUCTION .....	281
4.2	FUTURE OPERATIONS IN THE UNDERWATER ENGAGEMENT ZONE..	
	.....	282
4.3	THE IMPORTANCE OF ARRIVAL TIMELINE .....	283
4.4	THE NEED FOR PERSISTENT SYSTEMS .....	284
4.5	STANDOFF WEAPONS AND UNMANNED SYSTEMS.....	287
	GLOSSARY .....	289
	APPENDIX A: COMMAND EVALUATION MEASURES .....	305
	APPENDIX B: MODELING ANALYSIS SUPPORTING GRAPHS .....	306
B.1	Search and Detection .....	306
B.1.1	Pd of Red Submarines by Blue Assets.....	306
B.1.2	Instantaneous Pd for any Red Submarines by Blue Assets.....	308
B.2	Tracking .....	310
B.2.1	Tripwire Alternative.....	310
B.2.2	TSSE Alternative .....	315
B.2.3	War of Machines Alternative.....	320
B.2.4	LAG Alternative .....	325
	APPENDIX C: COST ANALYSIS .....	331
C.1	INTRODUCTION .....	331
C.2	ALTERNATIVE 1: TRIPWIRE.....	332
C.3	ALTERNATIVE 2: TSSE SEA TENTACLE .....	336
C.4	ALTERNATIVE 4: WAR OF MACHINES .....	345
C.5	ALTERNATIVE 4: LAG .....	350
C.6	COMPARISON OF ALTERNATIVES .....	353
	APPENDIX D: RELIABILITY AND SUSTAINABILITY .....	356
D.1	RELIABILITY AND SUSTAINMENT MODELING .....	356
D.1.1	Modeling UUV Reliability .....	356
D.1.1.1	Reliability States Diagram (Without Maintenance).....	358
D.1.2.1	Reliability States Diagram (With Maintenance).....	359
D.1.3.1	Modeling Parameters .....	359
D.1.4.1	Modeling Variables.....	360
D.1.5.1	Modeling Assumptions .....	361
D.1.6.1	EXTEND Modeling.....	364
D.1.7.1	Modeling Results (Without Maintenance).....	374
D.1.8.1	Modeling Result (With Maintenance) .....	378
D.1.9.1	Sensitivity Analysis .....	379
	APPENDIX E .....	386
	APPENDIX F: CLASSIFICATION OF SUBMARINES .....	390
	LIST OF REFERENCES.....	391
	INITIAL DISTRIBUTION LIST .....	397

THIS PAGE INTENTIONALLY LEFT BLANK

## LIST OF FIGURES

Figure 1: The SEDP .....	4
Figure 2: System Approach Diagram (Eisner, 2002).....	6
Figure 3: Data Flow Between Teams showing how each of the teams are fed information from outside reference sources. They then share information, performance specifications, requirements, and modeling outputs. Together the overall ASW model architecture provides data for analysis and recommendations. ....	7
Figure 4: Elements of a CSG and Their Respective Missions.....	12
Figure 5: Submarine Assets by Country and Type .....	13
Figure 6: “The Littorals” .....	17
Figure 7: Current SAG System Decomposition.....	23
Figure 8: System Decomposition Diagram for Sensors.....	26
Figure 9: Air Component Breakdown Chart.....	27
Figure 10: ASW Surface Component Breakdown.....	28
Figure 11: Subsurface Sensors Breakdown .....	29
Figure 12: IUSS Components .....	29
Figure 13: Hierarchical Structure of a Littoral Action Group .....	32
Figure 14: Display of Different States for Sensors .....	34
Figure 15: Generic Input-Output Model.....	40
Figure 16: Overall Functional Hierarchy .....	42
Figure 17: C4ISR Functional Hierarchy .....	45
Figure 18: Breakdown of Deployment Team’s Overall Functional Structure.....	46
Figure 19: Overall Sensors Approach to the ASW Problem .....	47
Figure 20: Functional Decomposition of Prosecute including Key Concepts that will need to be addressed in the ASW Problem .....	48
Figure 21: Breakdown of PDT’s Overall Functional Structure .....	49
Figure 22: Functional Flow Diagram.....	50
Figure 23: Breakdown of Deployment Team’s Overall Functional Structure.....	68
Figure 24: Function and Subfunctions for Sensors.....	70
Figure 25: Technology Roadmap for Sensors .....	73
Figure 26: Functional Hierarchy for Defeat.....	74
Figure 27: Functional Hierarchy (SoS Critical Functions).....	84
Figure 28: Command Subfunctions .....	84
Figure 29: Communicate Objectives Hierarchy Analysis .....	85
Figure 30: Network Objectives Hierarchy Analysis.....	86
Figure 31: Transfer ISR Data Hierarchy Analysis.....	87
Figure 32: Deploy Functional Objectives Hierarchy .....	89
Figure 33: Functional Hierarchy (SoS Critical Functions).....	90
Figure 34: Functional Hierarchy (Prosecute Subfunctions).....	91
Figure 35: Objectives Hierarchy for “Assess” Subfunction .....	92
Figure 36: Cueing Objectives Hierarchy Analysis .....	93
Figure 37: Track Objectives Hierarchy Analysis.....	94
Figure 38: Classification Objectives Hierarchy Analysis.....	95
Figure 39: Identification Objectives Hierarchy Analysis .....	96
Figure 40: Revised Functional Hierarchy for “Sensors” .....	97

Figure 41: Requirements Summary for “Assess” Subfunction.....	98
Figure 42: Revised Objectives Hierarchy for “Assess” Subfunction .....	99
Figure 43: Revised Objectives Hierarchy Matrix for “Search and Detection” Subfunction .....	101
Figure 44: Requirements for “Search and Detect” Subfunction.....	102
Figure 45: Requirements for “Tracking” Subfunction.....	103
Figure 46: Revised Objectives Hierarchy Matrix for “Tracking” Subfunction.....	104
Figure 47: Requirements for “Classification” Subfunction.....	104
Figure 48: Revised Objectives Hierarchy Matrix for “Classification” Subfunction .....	105
Figure 49: The PDT’s Value System Hierarchy.....	107
Figure 50: Future ASW CONOPS, Office of Force Transformation .....	110
Figure 51: Very Constrained Scenario Geography.....	112
Figure 52: Semiconstrained Scenario Geography.....	113
Figure 53: Coastal Scenario Geography .....	114
Figure 54: EM Attenuation in Seawater (Professor Robert Harney).....	122
Figure 55: Artist Rendition of an Undersea Network (University of Washington, Applied Physics Laboratory) .....	126
Figure 56: The EM Spectrum (US Department of Commerce).....	128
Figure 57: Theoretical LOS Distance based on Antenna Height (Dip).....	130
Figure 58: Undersea Communications System Alternatives Relationship Matrix .....	138
Figure 59: Atmospheric Communications Alternative Relationship Matrix.....	140
Figure 60: C4ISR Feasibility Matrix .....	142
Figure 61: Functional Objectives Hierarchy for Prosecute.....	150
Figure 62: Air Component Breakdown.....	153
Figure 63: Surface Component Breakdown.....	162
Figure 64: Subsurface Component Breakdown .....	168
Figure 65: SNR Based on Range and AN – 10 kHz 10 W .....	190
Figure 66: SNR Based on Range and AN – 12 kHz 10 W .....	190
Figure 67: SNR Based on Range and AN – 10 kHz 20 W .....	191
Figure 68: SNR Based on Range and AN – 12 kHz 20 W .....	192
Figure 69: Data Latency When COP Update is 0.1Mb .....	196
Figure 70: Data Latency When COP Update is 0.11Mb .....	198
Figure 71: Data Latency When COP Update is 0.12Mb .....	199
Figure 72: Data Latency Experience When COP Update Message is 0.05Mb .....	201
Figure 73: Data Latency Experienced When COP Update Message is 0.05Mb .....	202
Figure 74: Data Latency Experienced When COP Update Message is 0.1Mb .....	203
Figure 75: Data Latency Experienced When Input COP Messages are 8x Combined; Sent Message 0.1Mb.....	204
Figure 76: Data Latency When Input COP Messages are 16x Combined; Sent Update Messages 0.12Mb .....	205
Figure 77: An Example of a Triangular Distribution Utilized for Calculating the Transit Distance of Deployed Assets .....	212
Figure 78: Hypothetical UUV Deployment Module for Air Deployments .....	217
Figure 79: Tripwire – Number of Arrivals/Time Step.....	221
Figure 80: Tripwire – Individual Percent Capability/Time .....	222
Figure 81: Tripwire – Combined Percent Capability/Time .....	223

Figure 82: Tripwire – Logistical Arrival .....	224
Figure 83: TSSE Sea TENTACLE Sensor Grid .....	225
Figure 84: TSSE Sea TENTACLE – Individual Percent Capability/Time.....	226
Figure 85: TSSE Sea TENTACLE – Combined Percent Capability/Time .....	227
Figure 86: TSSE Sea TENTACLE – Logistical Arrival.....	228
Figure 87: War of Machines – Aircraft Percent Capability/Time .....	230
Figure 88: War of Machines – Aircraft and SSGN Percent Capability/Time .....	231
Figure 89: War of Machines – Combined Percent Capability/Time .....	231
Figure 90: War of Machines – Aircraft Logistical Arrival Without SSGNs .....	232
Figure 91: War of Machines – Total Asset Logistical Arrival Including SSGNs .....	233
Figure 92: LAG – Individual Percent Capability/Time Step.....	234
Figure 93: LAG – Combined Percent Capability/Time Step.....	235
Figure 94: LAG – Logistical Arrival .....	236
Figure 95: Alternative Confidence Intervals.....	237
Figure 96: MCA Metric with Baseline and a Sample Problem .....	245
Figure 97: Change Effectuated for MCA with Environmental Multiple at 1 .....	246
Figure 98: Parts that Comprise the Environmental Multiple .....	246
Figure 99: Pd of All Red Submarines by Blue Assets per Time Step for Each Alternative .....	251
Figure 100: Pd of Any Red Submarines by Blue Assets per Time Step for Each Alternative.....	252
Figure 101: Instantaneous Pd for any Red Submarine by Blue Assets per Time Step Showing Initial Pd as Assets Enter Theater and the Steady State Pd with Permanence of Assets in Theater.....	253
Figure 102: Probability that Blue Assets can Successfully Track Red Submarines per Time Step in 6-Minute Intervals for Alternative 1 – Tripwire .....	257
Figure 103: Probability that Blue Assets can Successfully Track Any One Red Submarine per Time Step in 6-Minute Intervals for Alternative 1 – Tripwire .....	258
Figure 104: Probability that Blue Assets can Successfully Track Red Submarines per Time Step in 6-Minute Intervals for Alternative 2 – TSSE.....	259
Figure 105: Probability that Blue Assets can Successfully Track Any One Red Submarine per Time Step in 6-Minute Intervals for Alternative 2 – TSSE.....	260
Figure 106: Probability that Blue Assets can Successfully Track Red Submarines per Time Step in 6-Minute Intervals for Alternative 3 – War of Machines.....	261
Figure 107: Probability that Blue Assets can Successfully Track Any One Red Submarines per Time Step in 6-Minute Intervals for Alternative 3 – War of Machines .....	262
Figure 108: Probability that Blue Assets can Successfully Track Red Submarines per Time Step in 6-Minute Intervals for Alternative 4 – LAG .....	263
Figure 109: Probability that Blue Assets can Successfully Track Any One Red Submarine per Time Step in 6-Minute Intervals for Alternative 4 – LAG.....	264
Figure 110: Snapshot of the Probability of Blue Assets Being Able to Track All Red Submarines by 240 Time Steps.....	265
Figure 111: Snapshot of the Probability of Blue Assets Being Able to Track Any One of Red's 8 Submarines by 240 Time Steps.....	266
Figure 112: Winter Propagation Loss in Bass Strait, LAT 40 50S LON 146 25E.....	273
Figure 113: Summer Propagation Loss in Bass Strait, LAT 40 50S LON 146 25E.....	273



Figure 114: Expected Detection Ranges in Southern Bass Strait, LAT 40 50S LON 146 25E.....	274
Figure 115: Expected Detection Range in Middle of Bass Strait, LAT 40 00S LON 146 30E.....	274
Figure 116: Expected Detection Range in Java Sea, LAT 04 32S LON 113 07E.....	275
Figure 117: Expected Detection Range off Coast of South Korea, LAT 37 54N LON 129 30E.....	276
Figure 118: Bass Strait Showing Red OPAREAs A, B, and C.....	277
Figure 119: The Inability of Nonpersistent Systems to Provide the Location of Enemy Forces Throughout the ASW Scenario is Evident.....	285
Figure 120: By Combining the Short-Lived UUVs With a Persistent Manned System, Enemy Detection can be Sustained Throughout the ASW Scenario.....	286
Figure 121: The Instantaneous and Cumulative Probability of Detection of an Enemy Submarine Leaving Port.....	287
Figure 122: The Trade-Off Between Trailing Range and Acceptable Kill-Chain Timelines is Critical.....	288
Figure 123: System Engineering and Design Process.....	302
Figure 124: Tripwire, Probability of Detection of All Red Submarines by Blue Assets per Time Step.....	306
Figure 125: TSSE, Probability of Detection of All Red Submarines by Blue Assets per Time Step.....	307
Figure 126: War of Machines, Probability of Detection of All Red Submarines by Blue Assets per Time Step.....	307
Figure 127: LAG, Probability of Detection of All Red Submarines by Blue Assets per Time Step.....	308
Figure 128: Tripwire Alternative Pd Representing Instantaneous Average Probability of Blue Detecting any Red Submarine at the Given Time Steps.....	309
Figure 129: Sea TENTACLE Alternative Pd Representing Instantaneous Average Probability of Blue Detecting any Red Submarine at the Given Time Steps.....	309
Figure 130: War of Machines Alternative Pd Representing Instantaneous Average Probability of Blue Detecting any Red Submarine at the Given Time Steps.....	309
Figure 131: LAG Alternative Pd Representing Instantaneous Average Probability of Blue Detecting any Red Submarine at the Given Time Steps.....	310
Figure 132: Probability that Blue Assets can Successfully Track Red Submarines per Time Step in 6 Minutes for Tripwire Alternative.....	311
Figure 133: Probability that Blue Assets can Successfully Track Red Submarines per Time Step in 12 Minutes for Tripwire Alternative.....	311
Figure 134: Probability that Blue Assets can Successfully Track Red Submarines per Time Step in 18 Minutes for Tripwire Alternative.....	312
Figure 135: Probability that Blue Assets can Successfully Track Red Submarines per Time Step in 24 Minutes for Tripwire Alternative.....	312
Figure 136: Probability that Blue Assets can Successfully Track Red Submarines per Time Step in 30 Minutes for Tripwire Alternative.....	313
Figure 137: Probability that Blue Assets can Successfully Track Red Submarines per Time Step in 36 Minutes for Tripwire Alternative.....	313

Figure 138: Probability that Blue Assets can Successfully Track Red Submarines per Time Step in 42 Minutes for Tripwire Alternative .....	314
Figure 139: Probability that Blue Assets can Successfully Track Red Submarines per Time Step in 48 Minutes for Tripwire Alternative .....	314
Figure 140: Probability that Blue Assets can Successfully Track Red Submarines per Time Step in 54 Minutes for Tripwire Alternative .....	315
Figure 141: Probability that Blue Assets can Successfully Track Red Submarines per Time Step in 6 Minutes for Sea TENTACLE Alternative.....	316
Figure 142: Probability that Blue Assets can Successfully Track Red Submarines per Time Step in 12 Minutes for Sea TENTACLE Alternative.....	316
Figure 143: Probability that Blue Assets can Successfully Track Red Submarines per Time Step in 18 Minutes for Sea TENTACLE Alternative.....	317
Figure 144: Probability that Blue Assets can Successfully Track Red Submarines per Time Step in 24 Minutes for Sea TENTACLE Alternative.....	317
Figure 145: Probability that Blue Assets can Successfully Track Red Submarines per Time Step in 30 Minutes for Sea TENTACLE Alternative.....	318
Figure 146: Probability that Blue Assets can Successfully Track Red Submarines per Time Step in 36 Minutes for Sea TENTACLE Alternative.....	318
Figure 147: Probability that Blue Assets can Successfully Track Red Submarines per Time Step in 42 Minutes for Sea TENTACLE Alternative.....	319
Figure 148: Probability that Blue Assets can Successfully Track Red Submarines per Time Step in 48 Minutes for Sea TENTACLE Alternative.....	319
Figure 149: Probability that Blue Assets can Successfully Track Red Submarines per Time Step in 54 Minutes for Sea TENTACLE Alternative.....	320
Figure 150: Probability that Blue Assets can Successfully Track Red Submarines per Time Step in 6 Minutes for War of Machines Alternative .....	321
Figure 151: Probability that Blue Assets can Successfully Track Red Submarines per Time Step in 12 Minutes for War of Machines Alternative .....	321
Figure 152: Probability that Blue Assets can Successfully Track Red Submarines per Time Step in 18 Minutes for War of Machines Alternative .....	322
Figure 153: Probability that Blue Assets can Successfully Track Red Submarines per Time Step in 24 Minutes for War of Machines Alternative .....	322
Figure 154: Probability that Blue Assets can Successfully Track Red Submarines per Time Step in 30 Minutes for War of Machines Alternative .....	323
Figure 155: Probability that Blue Assets can Successfully Track Red Submarines per Time Step in 36 Minutes for War of Machines Alternative .....	323
Figure 156: Probability that Blue Assets can Successfully Track Red Submarines per Time Step in 42 Minutes for War of Machines Alternative .....	324
Figure 157: Probability that Blue Assets can Successfully Track Red Submarines per Time Step in 48 Minutes for War of Machines Alternative .....	324
Figure 158: Probability that Blue Assets can Successfully Track Red Submarines per Time Step in 54 Minutes for War of Machines Alternative .....	325
Figure 159: Probability that Blue Assets can Successfully Track Red Submarines per Time Step in 6 Minutes for LAG Alternative.....	326
Figure 160: Probability that Blue Assets can Successfully Track Red Submarines per Time Step in 12 Minutes for LAG Alternative.....	326

Figure 161: Probability that Blue Assets can Successfully Track Red Submarines per Time Step in 18 Minutes for LAG Alternative.....	327
Figure 162: Probability that Blue Assets can Successfully Track Red Submarines per Time Step in 24 Minutes for LAG Alternative.....	327
Figure 163: Probability that Blue Assets can Successfully Track Red Submarines per Time Step in 30 Minutes for LAG Alternative.....	328
Figure 164: Probability that Blue Assets can Successfully Track Red Submarines per Time Step in 36 Minutes for LAG Alternative.....	328
Figure 165: Probability that Blue Assets can Successfully Track Red Submarines per Time Step in 42 Minutes for LAG Alternative.....	329
Figure 166: Probability that Blue Assets can Successfully Track Red Submarines per Time Step in 48 Minutes for LAG Alternative.....	329
Figure 167: Probability that Blue Assets can Successfully Track Red Submarines per Time Step in 54 Minutes for LAG Alternative.....	330
Figure 168: 21-inch UUV Learning Curves Showing Average Cost Per Unit of \$372,000 for 15 UUVs.....	334
Figure 169: Alternative 1 - Tripwire - Showing Breakdown of R&D, Procurement, and O&S Funding.....	335
Figure 170: Alternative 1 - Tripwire - Showing Percentages of R&D, Procurement, and O&S Funding.....	335
Figure 171: Large UUV Learning Curves Showing Average Cost Per Unit \$1,300,000 for 135 Large UUVs.....	338
Figure 172: UUV Sled Learning Curves Showing Average Cost Per Unit \$230,000 for 135 UUV Sleds.....	340
Figure 173: 9-inch Learning Curves Showing Average Cost Per Unit \$58,000 for 2,160 UUVs.....	341
Figure 174: 12.75-inch Learning Curves Showing Average Cost Per Unit \$101,000 for 810 UUVs.....	342
Figure 175: Alternative 2 - Sea TENTACLE - Showing Breakdown of R&D, Procurement, and O&S Funding.....	344
Figure 176: Alternative 2 - Sea TENTACLE - Showing Percentages of R&D, Procurement, and O&S Funding.....	344
Figure 177: Recharging Station Learning Curves Showing Average Cost Per Unit \$393,000 for 12 Recharging Stations.....	346
Figure 178: 21-inch Learning Curves Showing Average Cost Per Unit \$538,000 for 60 UUVs.....	348
Figure 179: Alternative 3 - War of Machines - Showing Breakdown of R&D, Procurement, and O&S Funding.....	349
Figure 180: Alternative 3 - War of Machines - Showing Percentages of R&D, Procurement, and O&S Funding.....	350
Figure 181: Alternative 4 - LAG - Showing Breakdown of R&D, Procurement, and O&S Funding.....	352
Figure 182: Alternative 4 - LAG - Showing Breakdown of R&D, Procurement, and O&S Funding.....	352
Figure 183: Comparison of Alternatives Across R&D Funding.....	353
Figure 184: Comparison of Alternatives Across Procurement Funding.....	354

Figure 185: Comparison of Alternatives Across O&S Funding..... 354  
Figure 186: Comparison of Alternatives Across R&D, Procurement, and O&S Funding  
..... 355

THIS PAGE INTENTIONALLY LEFT BLANK

## LIST OF TABLES

Table 1: ASW Sea Power 21: Near- and Long-Term .....	65
Table 2: Surface Force ASW Capabilities .....	162
Table 3: Platform and Sensor Matching .....	169
Table 4: Objectives and their Respective Alternatives .....	175
Table 5: Transit Distance for All Assets .....	212
Table 6: Modeling Input Data for Potential Assets .....	214
Table 7: Payload Data for Modeling Input .....	215
Table 8: Transit Time for a DDG by Color Code .....	219
Table 9: Tripwire Assets .....	220
Table 10: TSSE Sea TENTACLE Assets .....	225
Table 11: War of Machines Assets .....	229
Table 12: LAG Assets .....	234
Table 13: All-Inclusive List of Sensor Systems (Current, In Development, and In Concept) .....	248
Table 14: Comparison Chart of Pd=0.80 for Any and All Red Submarines Detected by Blue Assets .....	252
Table 15: Summary of Pd for each Alternative with the Start Hour, Maximum Pd, and Steady State Pd .....	254
Table 16: Pd of Combined Alternatives using Max Pd and Steady State Pd to Determine the Ideal Combination of Alternatives that Provides a Higher Pd .....	255
Table 17: Red Submarine Underway Time and Mission .....	278
Table 18: Alternative 1 (Tripwire) Blue Asset Capabilities .....	278
Table 19: Alternative 2 (TSSE Sea TENTACLE) Blue Asset Capabilities .....	279
Table 20: Alternative 3 (War of Machines) Blue Asset Capabilities .....	279
Table 21: Alternative 4 (LAG) Blue Asset Capabilities .....	280

THIS PAGE INTENTIONALLY LEFT BLANK

## LIST OF SYMBOLS, ACRONYMS AND/OR ABBREVIATIONS

3M	Maintenance, Material, Management
AAW	Air-to-Air Warfare
ADS	Advanced Distributed System
AEER	Advanced Extended Echo Ranging
ADAR	Air Deployable Active Receiver
AI	Artificial Intelligence
AIP	Air Independent Propulsion
AN	Ambient Noise
AO	Area of Operations
AOU	Area of Uncertainty
APV	Autonomous Profiling Vehicle
ARPDD	Airborne Radar Periscope Detection and Discrimination
ASDS	Advanced Seal Delivery System
ASROC	Anti-Submarine Rocket
ASuW	Anti-Surface Warfare
ASW	Anti-Submarine Warfare
ASWC	Anti-Submarine Warfare Commander
ASWCS	Anti-Submarine Warfare Combat System
AVTC	Advanced Video Tele-Conferencing
BER	Bit Error Rate
Bps	bits per second
BT	Bathythermograph
C2	Command and Control
C4	Command, Control, Communications, and Computers
C4I	Command, Control, Communications, Computers and Intelligence
C4ISR	Command, Control, Communications, Computers, Intelligence, Surveillance, and Reconnaissance
CBNRE	Chemical, Biological, Nuclear, Radiological, and Explosives
CCOI	Critical Contact of Interest
CDF	Cumulative Density Function



CDR	Commander
CEP	Circular Error Probable
CERTSUB	Certain, Submarine
CG	Guided Missile Cruiser
CL	Confidence Level
CNET	Command, Naval Education and Training
CNMOC	Commander, Naval Meteorological and Oceanographic Command
CNO	Chief of Naval Operations
COCOM	Combatant Commanders
COI	Contact of Interest
COMOPTEVFOR	Command, Operational Testing and Evaluation Forces
CONOPS	Concept of Operations
CONUS	Continental United States
COP	Common Operating Picture
COTS	Commercial-off-the-shelf
CSG	Carrier Strike Group
CSMA LAN	Collision Sense Multiple Access Loaded Area Network
CT <sub>N</sub>	Cumulative Total Cost of N Units
CUP	Common Undersea Picture
DADS	Deployable Autonomous Distributed System
DARPA	Defense Advance Research Projects Agency
dB	Decibels
DD	Spruance Class Destroyer
DDG	Guided Missile Destroyer
DHS	Department of Homeland Security
DI	Directivity Index
DICASS	Directional Command Activated Sonobuoy System
DIFAR	Directional Frequency Analysis and Recording
DLC	Data Link Communications
DOD	Department of Defense
DOT	Department of Transportation

EER	Extended Echo Ranging
EHF	Extremely High Frequency
ELF	Extremely Low Frequency
EM	Electro-Magnetic
EMCON	Emission Control
EMP	Electro-Magnetic Pulse
EOD	Explosive Ordnance Disposal
EPAS	Electro-Optic Passive ASW Sensor
ERS	European Synthetic Radar Satellites
ESG	Expeditionary Strike Group
ESM	Electronic Surveillance Material
EW	Electronic Warfare
FAS	Fast Attack Submarine
FCC	Federal Communications Commission
FCS	Fire Control Solution
FFG	Guided Missile Frigate
FLIR	Forward Looking Infrared
FLTCDR	Fleet Commanders
FMC	Fully Mission Capable
FNC	Future Naval Capabilities
FNMOCC	Fleet Numerical Meteorological and Oceanographic Command
FT	Failure Time
Gbps	Gega-bits per second
GFCS	Gun Fire Control System
GIG	Global Information Grid
HF	High Frequency
HGVA	High Gain Volumetric Array
HVU	High Value Unit
HWV	Heavyweight Vehicle
Hz	Hertz
ID	Identify/Identification

IEER	Improved Extended Echo Ranging
IFF	Identification of Friend/Foe
INFOCON	Information Operations Condition
I-O	Input-Output
IPR	Interim Progress Report
IR	Infrared
IRDS	Infrared Detection System
ISR	Intelligence, Surveillance, Reconnaissance
IUSS	Integrated Undersea Surveillance System
IWS	Integrated Warfare Systems
JCIDS	Joint Capability Integration and Development System
JDAM	Joint Direct Attack Munition
JELO	Joint Expeditionary Logistics Operations Model
JFEO	Joint Forcible Entry Operations
JSF	Joint Strike Fighter
JSOW	Joint Stand Off Weapon
Kbps	Kilo-bits per second
KCT	Kill-Chain Timeline
KHz	Kilohertz
KW	Kilowatt
KWh	Kilowatt Hours
LAG	Littoral Action Group
LAMPS	Light Airborne Multi-Purpose System
LBVDS	Lightweight Broadband Variable Depth Sonar
LC	Landing Craft
LCAC	Landing Craft Air Cushion
LCM	Landing Craft Mechanized
LCS	Littoral Combat Ship
LEO	Low Earth Orbit
LF	Low Frequency
LFAR	Low Frequency Analysis and Recording

LFAS	Low Frequency Active Sonar
LIDAR	Light Detection and Ranging
LOS	Line of Sight
LTA	Lighter Than Air
LTAV	Lighter Than Air Vehicles
LVAA	Littoral Volumetric Acoustic Array
LVT	Landing Vehicle Tank
LWAA	Large Wide Aperture Array
LWV	Light Weight Vehicle
MAD	Magnetic Anomaly Detector
Mbps	Megabits per second
MCA	Mission Capability Assessment
MCM	Mine Counter Measures
METOC	Meteorological and Oceanographic Center
MF	Medium Frequency
MFTA	Multi-Function Towed Array
MIW	Mine Warfare
MMA	Multi-Mission Aircraft
MOBS	Mobile Off-Board Source
MOE	Measures of Effectiveness
MOP	Measures of Performance
MPA	Maritime Patrol Aircraft
MTBF	Mean Time Between Failures
MW	Megawatt
NAMP	Naval Aviation Maintenance Program
NATO	North Atlantic Treaty Organization
NAVSEA	Naval Sea Systems Command
NDP	Naval Doctrine Publication
NEASW	Network-Enabled ASW
NetSAT	Netted Search, Acquisition and Targeting
NM	Nautical Miles

NMC	Non-Mission Capable
NMS	National Military Strategy
NPS	Naval Postgraduate School
NSS	Naval Simulation System
NTMLTA	Near Term Multi-Line Towed Array
NTOMS	NATO Tactical Ocean Modeling System
NTT	Non-Traditional Tracking
NUWC	Naval Undersea Warfare Center
O&S	Operating & Support
OA	Operating Area
ONR	Office of Naval Research
OODA	Observe, Orient, Decide, Act
OPAREA	Operating Area
OPNAV	Naval Operations
OSD	Office of the Secretary of Defense
OTH	Over-the-Horizon
PANDA	Portable Ambient Noise Data Acquisition
PC IMAT	Personal Computer-based Interactive Multi-sensor Analysis Training
Pd	Probability of Detection
PDF	Probability Density Function
PDT	Platform Development Team
PEO	Program Executive Office
PMC	Partially Mission Capable
PMI	Prevention of Mutual Interference
PMS	Preventative Maintenance Schedule
POR	Program of Record
PSL	Pressure Spectrum Level
R&D	Research & Development
RAP VLA	Reliable Acoustic Path Vertical Line Array
REA	Rapid Environmental Assessment

RAPID	Radar Augmentation for Periscope Identification
RF	Radio Frequency
RHIB	Rigid Hull Inflatable Boat
RMP	Recognized Maritime Picture
RMV	Remote Minehunting Vehicle
ROE	Rules of Engagement
ROMANIS	Remotely Operated Mobile Ambient Noise Imaging System
RWT	Receive While Transmit
SAG	Surface Action Group
SAR	Synthetic Aperture Radar
SATCOM	Satellite Communications
SCN	Signal Case Number
SEA-8	Systems Engineering and Analysis Cohort Eight
SEDP	Systems Engineering Design Process
SEID	Specific Emitter Identification
SHF	Super High Frequency
SIPS	Scalable Improved Processing Sonar
SL	Signal Loss
SLOC	Sea Lines of Communication
SNR	Signal to Noise Ratio
SOF	Special Operations Forces
SoS	System of Systems
SOSUS	Sound Surveillance System
SPAWAR	Space and Naval Warfare Systems Command
SS	Steady State
SSBN	Nuclear Ballistic Missile Submarine
SSGN	Ohio Class Cruise Missiles Submarine
SSN	Attack/Nuclear Submarine
SURTASS	Surveillance Towed Array Sonar System
SUW	Surface Warfare
SVP	Sound Velocity Profile

SWBS	Seaweb-Based Sensors
SWDG	Surface Warfare Development Group
SWEEP	Shallow Water Expendable Environmental Profiler
SWO	Surface Warfare Officer
TACON	Tactical Control
T-AGOS	Towed-Array Ocean Going Surveillance Ship
TBD	To Be Determined
TFASW	Task Force Anti-Submarine Warfare
TL	Transmission Loss
TRL	Technology Readiness Level
TSSE	Total Ship Systems Engineering
TYCOM	Type Commanders
UAV	Unmanned Aerial Vehicle
UC	Undersea Communications
UDM	UUV Deployment Model
UEZ	Underwater Engagement Zone
UHF	Ultra High Frequency
UJEZ	Undersea Joint Engagement Zones
UNCLAS	Unclassified
US	United States
USAF	United States Air Force
USV	Unmanned Surface Vehicle
USW	Undersea Warfare
UTAS	Unmanned Lightweight Towed Arrays
UUV	Unmanned Undersea Vehicle
U/W	Underway
VAMOSOC	Visibility and Management of Operating and Support Costs
VHF	Very High Frequency
VID	Visual Identification
VLAD	Vertical Line Array Directional Frequency
VLF	Very Low Frequency

VLS	Vertical Launching System
VoIP	Voice over Internet Protocol
VSD	Value Systems Design
WAN	Wide Area Network
WHOI	Woods Hole Oceanographic Institute
WMA	Warfare Mission Area
XBT	Expendable Bathythermograph Sonobuoy



THIS PAGE INTENTIONALLY LEFT BLANK

## EXECUTIVE SUMMARY

The Littoral Anti-Submarine Warfare (ASW) in 2025 project represents a cooperative multi defense research study involving more than 48 students from the Naval Postgraduate School (NPS) Systems Engineering and Analysis (SEA) curriculum, the Total Ship Systems Engineering (TSSE) program, and other student groups on campus, as well as more than 15 faculty members. The project was the result of tasking provided by the office of the Deputy Chief of Naval Operations for Warfare Requirements and Programs (OPNAV N7) to the Wayne E. Meyer Institute of Systems Engineering.

The OPNAV N7 tasked the Meyer Institute to perform a study of System-of-Systems (SoS) architectures for the conduct of undersea warfare in the littorals in the 2025 time frame. To that end, SEA Group 8 (SEA-8) was tasked with developing those architectures, operations and associated capabilities required for the United States Navy (USN) to meet the challenges contained within the Chief of Naval Operation's (CNO) "Anti-Submarine Warfare, Concept of Operations (CONOPS) for the 21<sup>st</sup> Century," published on 20 December 2004. As a systems engineering team, SEA-8 followed a methodical process that provided unbiased, quantifiable insight and possible architectural solutions for this future littoral ASW challenge.

SEA-8 used the Systems Engineering Design Process (SEDP) designed by Andrew Sage and James Armstrong as the foundation of analysis during the integrated cross-campus study. The SEDP is an iterative process that guides an engineering design team to solutions through four phases: Problem Definition, Design and Analysis, Decision Making, and Implementation.

During the Problem Definition Phase, SEA-8 conducted an in-depth futures analysis study. It was determined that a threat submarine force need only be successful in attack once, whereas US ASW forces had to be successful in defense every time. A successful enemy first strike against the sea base or a force on force kill against a traditional ASW asset might undermine American support at home. This analysis inferred a hesitancy to engage the enemy through traditional means—not because we cannot win, but because the definition of "winning" has changed. SEA-8 perceived that in order to win, the US must act quickly, decisively, and with minimal loss of capital assets or friendly life.

When entering into the Design Analysis Phase, SEA-8 generated four alternative ASW solutions that sought to neutralize the enemy threat, while holding friendly forces at safe distances using standoff, distributed, unmanned systems that leveraged high technology to achieve lower risk. These systems used different combinations of rapidly deployable, netted sensing systems, autonomous Unmanned Undersea Vehicles (UUVs) and advanced airborne-delivered floating sensors. As a baseline for comparison, SEA-8 also generated a fifth ASW architectural solution that used legacy systems (Virginia-class submarines and rotary wing ASW aircraft) in concert with anticipated future ASW assets (DD(X) and the Littoral Combat Ship) to execute traditional ASW methods.

Analysis of these alternatives was performed via modeling and simulation against the backdrop of a real world “defense of island nation” scenario, where the threat systems were Air Independent Propulsion (AIP) and fuel cell-powered submarines. SEA-8 used several physics-based models to input key ASW performance parameters into a single higher-level, entity-based, Monte Carlo simulation model, Naval Simulation System (NSS). Through this high-level model, SEA-8 was able to create a digital battlespace, where Red and Blue forces met, and the results of those interactions were recorded. Modeling performance comparisons were conducted, and the analysis of that data provided SEA-8 with valuable insights into each of the alternatives as well as into the future conduct of littoral ASW.

Keeping with the Secretary of Defense’s 10/30/30 construct, SEA-8 evaluated these five competing ASW alternative architectures by their ability to:

- begin ASW operations within 72 hours;
- seize the initiative within 10 days;
- be able to sustain ASW denial for 30 days; and
- permit follow on redeployment actions 30 days later

The results of this analysis led SEA-8 to the following conclusions:

*There are no perfect systems.*

The Littoral ASW in 2025 study found that no single alternative was the best solution for all ASW scenarios. Theater specific variables such as threat, geography,

remoteness of location, ambiguous warning periods, Red-force timelines, and differing Blue-force readiness profiles prevented SEA-8 from determining a single dominant solution. While each competing alternative ASW force structure had strengths, each also had weaknesses. Some alternatives were logistically burdensome, others could not respond quickly when warning timelines were short, and those that could be rapidly deployed tended to lack pervasive endurance. Pronounced differences in detection and tracking capabilities exist between alternatives, but even the worst performer could be effective if the Blue timeline was flexible. The best solution may be a combination of system architectures that could be tailored to suit specific theater scenario needs.

*Reaction time is the key driver to seizing the initiative.*

The enemy submarine was most vulnerable entering and exiting their home ports, due primarily to restricted waterways, where position and movements were predictable. Therefore, detecting and tracking these submarines as they were leaving port became an important part of SEA-8's research study. However, enemy force actions were uncertain and (without any future intelligence-gathering advantage) attempting to determine when and from where they were to deploy their submarines was difficult. Warning timelines were often ambiguous and unpredictable. During modeling and simulation, SEA-8 was unable to begin ASW operations within 3 days or to seize the initiative within 10 days without leveraging the delivery flexibility and speed associated with strategic air assets such as B-2 and B-52 delivery of nontraditional ASW assets such as UUVs and netted sensor grids. In order to hedge against uncertain enemy timelines, quick reaction and rapidly deployable system architectures proved advantageous. To this end, airborne deployment methods that used strategic air to insert nontraditional ASW assets appear to be least sensitive to enemy initiative.

*Persistent systems are required to sustain ASW denial.*

Constant presence of detection systems was required to effectively sustain ASW for 30 days. Ability to achieve undersea control was dependent on employing systems that were persistent in both time and space. Traditional methods used relatively small numbers of sensing platforms over large areas. These assets were persistent in time, but

due to their limited number were not persistent in space. Nontraditional methods (such as rapidly deployed sensor grids and UUVs) proved to be persistent in space, but without improvements in system recharging, tending, and/or replacement they lacked the staying power of more traditional manned assets.

*Kill-Chain Timeline (KCT) trade-offs exist between traditional and nontraditional ASW methods.*

Traditional manned trailing assets require short KCTs because of the need for manned systems to operate from a safe trailing distance in order to prevent counterdetection and countertargeting. While maintaining safe standoff, a quieter future enemy will further complicate the problem for manned platforms. Traditional ASW forces, using traditional ASW methods, have to make rapid choices concerning whether or not to shoot or else risk losing contact with a perspective target. By comparison, invasive nontraditional unmanned trailing systems that are capable of tracking at a closer range, decreased their probability of lost track and allowed for the use of longer KCT capable weapons systems.

Short KCTs relied on rapid rules of engagement (ROE) decisions and required the engaging asset to either be the detecting asset or be within close proximity when detection occurred. Nontraditional tracking and trailing methods allowed for a longer KCT and expanded the engagement envelope to include standoff weapons.

*Undersea Joint Engagement Zones (UJEZ) are the key to unlocking the power of future ASW technology.*

Finding that no single ASW alternative was the best solution for our littoral ASW scenario, and after gaining insight on the preceding themes of Reaction Time, Presence, and KCT tradeoffs, SEA-8 concluded that a dramatic shift in ASW doctrine and methodology was required to unleash the power of future ASW technologies. The waterspace management and Prevention of Mutual Interference (PMI) techniques employed during the late 20th century are akin to stove-pipe engineering; they prevent complementary platforms and sensors from operating together to fill other systems' weaknesses in deployment timelines, endurance, prosecution, and engagement

capabilities. This study shows that future littoral ASW requires a scenario-specific mix of sensors, UUVs, and manned platforms that will operate with one another in the same waterspace. It is imperative that these forces be designed to operate cooperatively, with low false positive and low fratricide rates, in a manner that more accurately resembles the Joint Engagement Zone currently used by air warfare systems.

From the results of the Littoral ASW in 2025 project, SEA-8 formulated a series of recommendations concerning future ASW research, development, tactics and doctrine.

### **Research**

Recommend follow-on study, using the nontraditional systems envisioned in this report, to compare the relative effectiveness of mixed combinations of ASW force alternatives with respect to threats, geographies, and political scenarios.

### **Development**

The Littoral ASW in 2025 study showed that larger numbers of simpler (and perhaps less expensive) platforms generated effective search rates that could not be matched by smaller numbers of highly capable traditional assets. To leverage this sensing advantage, SEA-8 recommends aggressive development of autonomous UUV technology and UUVs that possess the capability to search, detect, track, trail, and engage enemy submarines.

SEA-8 also recommends that rapidly deployable sensing grids and the communication capabilities required to develop a common undersea picture be developed. This capability will be used to help cue UUVs to the presence of enemy submarines and expand the effective search rates of more traditional manned ASW assets.

Finally, in order to unlock the full potential of UUVs and remote sensors, SEA-8 believes that it is vitally important to develop, in parallel, those systems that can give nontraditional assets greater endurance and staying power. Systems such as undersea recharging stations and rapid remote reseeding methods will greatly increase the overall effectiveness of these future assets.

## **Tactics**

SEA-8 recommends that the USN conduct operational planning and testing that employs strategic air assets to rapidly deploy and expand the reach of tactical ASW operations. The potential to stealthily insert nontraditional ASW assets deep into enemy waterspace, near port entrances, and choke points, is promising and should be vigorously explored.

SEA-8 recommends that gliding body shells, similar to the Joint Standoff Weapon (JSOW), be developed that can be used to deliver netted sensors and UUVs close to enemy shorelines and harbors. Much like the JSOW, these glide bodies should be made low-observable so as to allow for the clandestine establishment of an ASW system within an enemy's waterspace. Systems such as this would allow the strategic air asset to remain at a safe standoff range, while delivering salvos of these nontraditional ASW assets.

## **Doctrine**

SEA-8 recommends that the USN evolve from waterspace management and PMI techniques of the past toward a more comprehensive undersea battlespace management doctrine (such as the UJEZ) of the future. We recommend that the Submarine and Undersea Warfare communities lead the way in overcoming the obstacles associated with the transition to the UJEZ.

THIS PAGE INTENTIONALLY LEFT BLANK



## ACKNOWLEDGEMENT

The integrated project of SEA-8, Littoral Warfare in 2025, would like to express our thanks and sincere gratitude for the time, dedication, expertise and guidance of the following individuals.

VADM Roger Bacon, USN (Ret.)  
Dr. Frank Shoup  
RADM Richard Williams, USN (Ret.)  
Professor Matthew Boensel  
Dr. Ravi Vaidyanathan  
Dr. Dave Olwell  
Dean Wayne Hughes  
CAPT Jeff Kline, USN (Ret.)  
CAPT Starr King, USN  
Professor Thomas Hoivik  
Dr. Daniel Nussbaum  
Mr. John Ruck  
CDR David Gilbert, USN (Ret.)  
Dr. Gene Paulo  
Dr. Jan Breemer  
CAPT Allan Galsgaard, USN  
Dr. Samuel Buttrey  
Dr. Robert Harney  
Professor Mark Stevens  
Professor Bard Mansager  
Professor Doyle Daughtry  
Professor William Solitario  
Professor Gregory Miller

Additionally, we would like to thank the remaining faculty and staff of the Wayne Meyer Institute of Systems Engineering who provided both direct and/or indirect support to SEA-8's project success. Also, we would like to extend our thanks and appreciation to our families, whose unwavering patience, understanding, and support during long hours and lost weekends was essential for the successful completion of our project.

THIS PAGE INTENTIONALLY LEFT BLANK

## **1.0 INTRODUCTION**

### **1.1 PURPOSE**

The purpose of this report on Undersea Warfare (USW) is to detail the results of the Wayne E. Meyer Institute's cross-campus study of "Littoral Antisubmarine Warfare in 2025." Conducted at the Naval Postgraduate School from July 2005 through December 2005, this study, led and managed by students in the Systems Engineering and Analysis curriculum, includes contributions from many members of the NPS academic community, including a major contribution from the Total Ship Systems Engineering (TSSE) program. This report fulfills a major portion of the SEA student's requirement to receive a Masters of Science degree in *Systems Engineering and Analysis*.

### **1.2 TASKING**

Working with their project advisors, students in the eighth section of the Systems Engineering and Analysis Cohort Eight (SEA-8) at the Naval Postgraduate School (NPS) were tasked with leading a six-month study focusing on the development of a full systems engineering analysis of potential US Navy littoral antisubmarine warfare (ASW) efforts as it pertains to battlespace preparation and monitoring, persistent detection and cueing, combined arms prosecution, high volume search and kill rates, nontraditional ASW methodologies, and ASW defense-in-depth.

In preparation for this tasking, SEA-8 students attended a series of classes in the UW 3301 Naval Postgraduate School course, The History of Undersea Warfare in the 20th and 21st Centuries, taught by the Chair Professor, Undersea Warfare, VADM Roger F. Bacon, USN (ret). This was completed prior to commencement of the six-month project.

SEA-8's major responsibility was to serve as the lead engineering team, supported by other collaborative teams from across the NPS student body and faculty, by employing the project management tools and methodology studied in their course work over the previous 18 months in residence.

**Deliverables:** SEA-8 was specifically tasked to provide the following:

- **Informal Interim Progress Report (IPR):** Four informal briefings were conducted between June and October 2005, during which SEA-8 updated the Meyer Institute faculty and staff on project progress with regard to research, analysis, modeling, management planning, and their cross-campus partnership studies
- **A Formal Briefing:** Conducted on 7 December 2005, this briefing of the entire project to senior Navy leadership and other invited visitors from the military, academia, and the defense industry was held at NPS and included a comprehensive study presentation conducted by SEA-8, an alternative design brief conducted by TSSE, as well as several separate in-depth briefings conducted by the individual SEA-8 teams covering their individual research and conclusions
- **A Technical Report:** The ultimate deliverable, consisting of the following technical report delivered in December 2005, it covered all aspects of the integrated study

### 1.3 SYSTEM ENGINEERING METHODOLOGY

Due to the scope and complexity of this particular subject, the security requirements inherent in modern ASW—along with the requirement to keep this study unclassified (UNCLAS)—and the relatively short time available, SEA-8’s focus was bound to the following study plan:

- Employ the Systems Engineering Design Process (SEDP),<sup>1</sup> the Systems Approach, as well as other systems engineering methodologies to analyze alternative US ASW force structure options operating in a semiconstrained sea-space 20 years in the future
- Baseline the problem using a current force mix to analyze and compare several similar future force mixes expected to be in operation by 2025

---

<sup>1</sup> Sage, Andrew R., James E. Armstrong, Introduction to Systems Engineering, John Wiley & Sons, Inc., New York, 2000, p. 144.

- Conduct a gap analysis between current force structure and the needed future force structure based on a comprehensive futures analysis to identify potential holes in current defense planning
- Make recommendations to Navy leadership to aide in future decision making

Throughout this process, various members of the NPS cross-campus community, including the TSSE cohort, proposed improvements in planning and design of system alternatives in an effort to ensure that the Navy meets forecasted future threats in littoral ASW.

To conduct this study, SEA-8 formulated a mix of legacy and future platforms and capabilities that could be modeled and tested to establish their capacity to meet the identified future threats. Through this modeling and simulation process, SEA-8 hopes to provide decision makers and stakeholders with a series of detailed performance schedules and cost break-downs that will aid in future acquisition and employment strategy decision making, as well as offering some potential alternatives for their consideration.

**Team Structure:** To facilitate this study, SEA-8 organized into functional teams early on whose division was based on the identified critical aspects of the overall ASW system architecture. The team breakdown was as follows:

- Deployment Team
- Sensors Team (Prosecute)
- C4ISR Team (Command)
- Platform Design Team (PDT) (Modeling)

Each team developed their respective Problem Definition, Needs Analysis Alternatives Generation, and Modeling Analysis studies in accordance with the SEDP, the Systems Approach, or some hybrid of each, appropriate to the specific functionality of their respective areas of research, while at the same time, working together to share specifications, requirements, objectives, and goals to ensure coordination and unity of effort in providing solutions to the overall project problem statement.

**The SEDP:** There are many methods and processes available for conducting systems engineering analysis, and, while no one method is best suited for every project,

SEA-8 made the decision early on to use the SEDP designed by Andrew Sage and James Armstrong as the foundation of analysis in this integrated cross-campus study.

The SEDP focuses on practical analysis and includes many problem-solving techniques and interpretation methods that can be applied throughout the life-cycle of a complex system-of-systems (SoS) to gain understanding and insight into product improvement and design.

Figure 1 depicts the SEDP process. SEA-8’s specific study of future ASW systems began with the Problem Definition Phase of the SEDP and followed that process where appropriate through the Decision-Making Phase. Although the SEDP process continues beyond the Decision-Making Phase, it was outside the scope of SEA-8’s tasking to conduct those portions of the process that cover Product Implementation. Therefore, SEA-8 strove to analyze current and future ASW Command, Control, Communications, Computers, Intelligence, Surveillance, and Reconnaissance (C4ISR) systems existing in the Navy’s program of record (POR), propose alternatives, and inform potential decision makers of the most appropriate system architectures to achieve success in littoral ASW in the 2025 time frame.

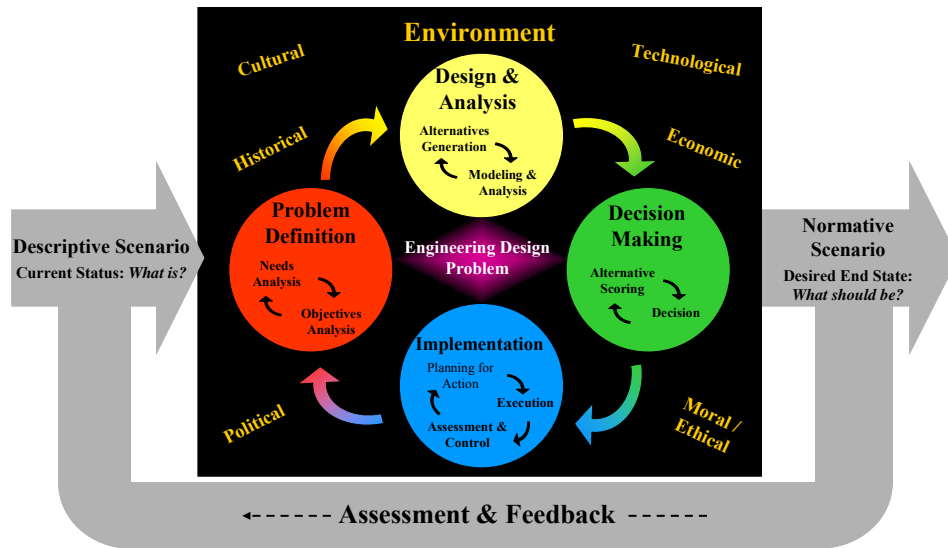


Figure 1: The SEDP

- **Problem Definition Phase** – Focused research and interaction with clients (sponsors, decision makers, and experts in the field), as well as early contact with others involved with system development such as mechanical engineers, aeronautical engineers, operators, and contractors, as

appropriate, to create a list of system requirements

- **Needs Analysis** – (Problem Definition Phase) – The formulation of a successful system depends on meeting the effective need of the customer, stakeholder, or decision maker. The first phase of the SEDP is designed to identify all of the factors that relate to the customer’s implicit and explicit need. Analysis was conducted on current ASW systems, proposed future systems, and stakeholder requirements, all in an effort to produce a refined effective need statement which framed the rest of the ASW analysis portion of the project
- **Objectives Analysis** – (Problem Definition Phase) – After the effective need for the ASW system was identified, the second step in the SEDP began in an effort to correctly identify the objectives of the system. These objectives state what stakeholders intend to accomplish with the system once operational. Correctly identifying these system objectives was crucial to ensuring that proposed alternatives meet the effective need of the Navy in 2025
- **Design and Analysis Phase** – A more detailed interaction with systems component engineers to turn the system “requirements” as identified in the Problem Definition Phase into technologically feasible systems capabilities
  - **Alternatives Generation** – (Design and Analysis Phase) – Using the objectives identified in the Problem Definition Phase, SEA-8 then worked with many members of the NPS cross-campus community (students, faculty, and researchers) as well as numerous subject matter experts from across the Navy to develop viable alternatives to meet the identified needs and objectives
  - **Modeling and Analysis** – (Design and Analysis Phase) – Various modeling tools were used to test and refine proposed ASW alternatives. The results of the individual team modeling efforts were then used to inform the greater SEA modeling efforts led by

the overarching Modeling Team. These results form many of the foundational constraints on the overall SEA-8 analysis of littoral ASW

- **Decision-Making Phase** – Finally, SEA-8 summarized the research to date by offering actionable steps to better posture the US Navy for success in littoral ASW in the 2025 time frame, thus meeting the needs of their stakeholders

**Systems Approach:** A second method applied by SEA-8 was the Systems Approach, in which analysis was conducted on all system processes to highlight the interactions within the system. In this approach, all processes must be repeatable for designing, developing, and operating a system under study. This approach also ensures that many alternatives will be considered, and that the proposed solution will be a refined system. Figure 2 displays the individually numbered steps, iteration phases, and an overview of the systems approach.

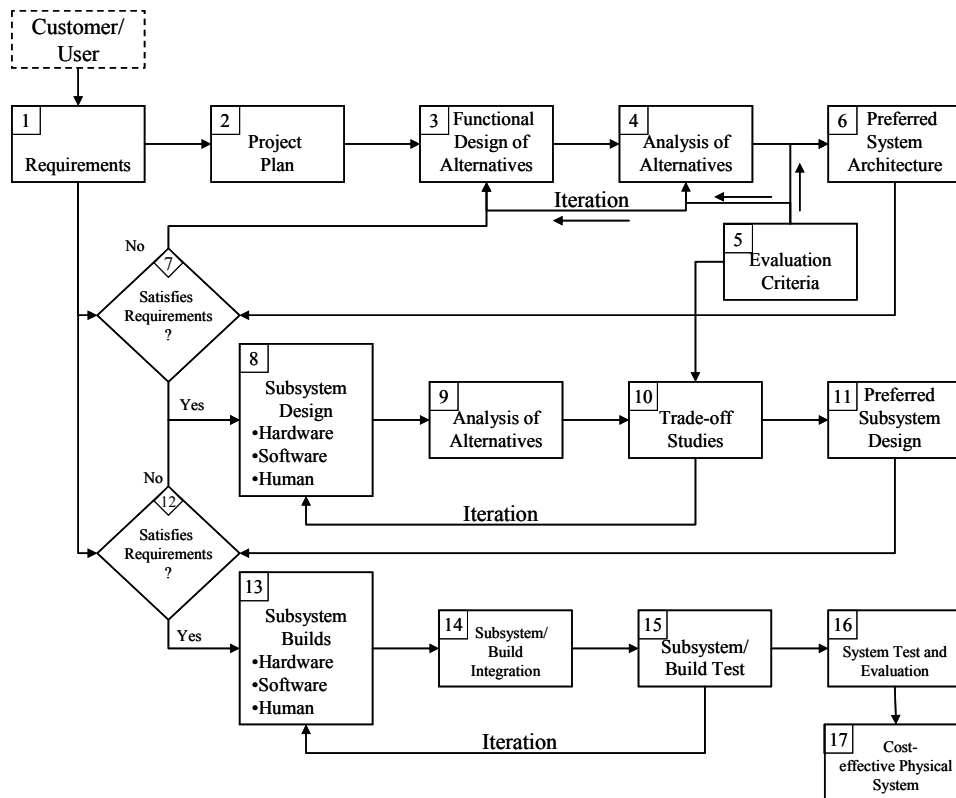
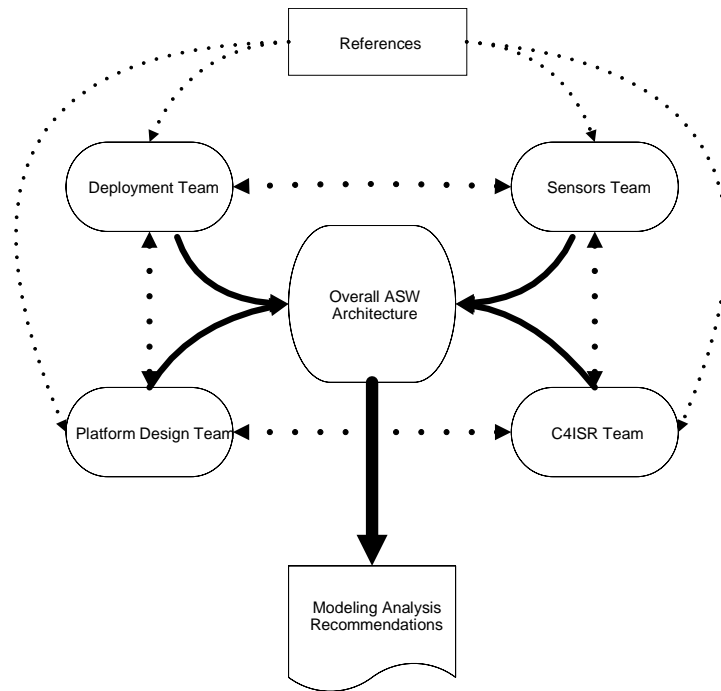


Figure 2: System Approach Diagram (Eisner, 2002)



While both the Systems Approach and the SEDP are iterative and have some commonality, they are also different in many ways. The SEDP ensures that every aspect of one phase is complete before moving to the next phase—such as when going from the Needs Analysis Phase to the Design and Analysis Phase. In the System Approach, the starting point of resolution of the project is in Step 3: Functional Design of Alternatives. Once this point is reached, every step beyond this is iterative. If a flaw is discovered in the alternative design, the System Approach is such that the iterative loop allows the systems engineer to return to the functional design and start over or make revisions to existing designs.

**Overarching Modeling Efforts:** The SEA-8 teams each designed modular models that provided inputs to the overall ASW architecture model as depicted in Figure 3.



**Figure 3: Data Flow Between Teams** showing how each of the teams are fed information from outside reference sources. They then share information, performance specifications, requirements, and modeling outputs. Together the overall ASW model architecture provides data for analysis and recommendations.

From these models output data was analyzed to provide recommendations concerning the following:

- Battle space preparation and monitoring
- Persistent detection and cuing
- Combined arms prosecution
- High volume search and kill rates
- Non-traditional methods
- Defense in depth

Specific conclusions drawn from modeling efforts concerning future US force capabilities and their relationship to any of the above issues are enunciated through this thesis technical report and were briefed during the formal briefing. The main body of this report, beginning in Section 2, will provide an overall view of SEA-8's execution of the SEDP and how the results of each of the four teams were used to find solutions to the overall littoral ASW problem. Any results or studies that go beyond the unclassified level will be included in a follow-on secret document entitled "Application of Littoral ASW in Full Spectrum Warfare 2025." Appendix G discusses the application of SEA-8's study on Littoral ASW in 2025 to Global ASW CONOPS Proposal of 2005. This appendix is classified SECRET and can be found in the Dudley Knox Library, Naval Postgraduate School, Monterey, California.

#### **1.4 SCENARIO**

SEA-8 constructed a simple campaign scenario as a frame of reference to use as a baseline to judge competing system alternatives as they entered into their analysis of littoral ASW. Based on SEA-8's tasking, and the relatively short amount of time to conduct the study, a decision was made to focus only on what many subject matter experts consider the most challenging littoral environment—the defense of an island nation in confined waters.

This restriction led to the decision to model the environment of the Bass Strait separating Australia and Tasmania, which was chosen because it easily represents many

similar regions of the world where the US may be forced to conduct littoral ASW in the time line provided.

The basic campaign scenario calls for US Forces to rapidly respond to Australian aggression against the relatively undefended Tasmania. Specifically for this study, US ASW forces must deploy into the Bass Strait to neutralize enemy submarines and their associated unmanned undersea vehicles (UUVs), within three days of notification, to facilitate friendly follow-on strike group operations designed to deter an Australian invasion.

This scenario is not intended to serve as a campaign analysis, test future operational plans, or suggest any future threat posed by the country of Australia. It was simply chosen based on the unique geography of the Strait and the wealth of unclassified environmental data available, all of which will be discussed later in this study.

## 2.0 PROBLEM DEFINITION

### 2.1 NEEDS ANALYSIS

#### 2.1.1 Introduction and Concept Development

The initial phase of a systems engineering approach requires the analyst to thoroughly review an existing system, determine if the system meets or fails to meet the expressed need of the original problem statement, and progress to the next phase of alternatives generation in order to propose alternatives that will meet the expressed need of the stakeholder, client, or decision maker.

This initial phase is termed “needs analysis” and comprises the following elements:

1. primitive need
2. system decomposition
3. stakeholder analysis
4. input-output model
5. functional analysis to include decomposition, hierarchy, and flow diagrams
6. futures analysis

The end result of the needs analysis phase is a revised problem statement, called the “effective need.”

However, prior to conducting any analysis of existing or future ASW system’s, SEA-8 first had to conduct an extensive background research program designed to educate all participants about ASW.

#### 2.1.2 Understanding Anti-Submarine Warfare

**Definition:** The Navy defines the primary goal of ASW as denying the enemy the “effective” use of their submarines, and while the act of denying can mean a great many things, it usually means deterring an enemy submarine from its mission, and if needed, destroying it. The process required to accomplish this end (detecting, tracking, localizing,

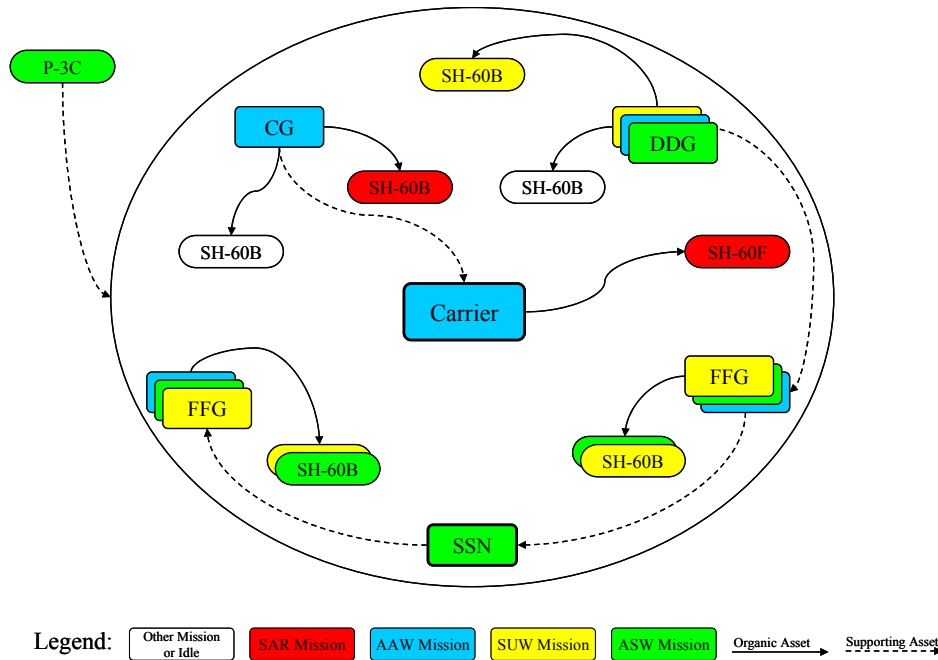
and destroying)<sup>2</sup> is accomplished through a mix of naval platforms such as aircraft, surface ships, and friendly submarines. In the near future, various unmanned vehicles will likely also join this list of platforms. The individual platforms can be further broken down into their associated weapons and sensor systems. The combination of platforms, weapons, and sensors, as well as the operational tactics and doctrine that dictate their combat employment, are critical to the successful completion of any ASW mission.

**Assets:** The platforms themselves almost always make up larger systems of elements, most often forming a multimission carrier strike group (CSG) or expeditionary strike group (ESG). Being multimission means that ASW makes up only one of many core competency warfare areas that each group must be ready to perform at any time. The competition between competing mission areas for the limited resources deployed will be critical to the ASW mission and the results of this study, and will be covered in more detail later in this report. The composition of a typical CSG is shown in Figure 4.

Another deployment alternative is that of a Surface Action Group (SAG) usually consisting of cruisers, destroyers, and/or frigates. Sometimes deployed as independent stand-alone groups in a regular deployment schedule, and sometimes drawn from ships already on deployment as part of formal strike groups, a SAG has the ability to place more emphasis on the offensive ASW operations since CSG/ESG ASW operations usually focus on defensive ASW designed to preserve the high value unit (HVU) within the group—the aircraft carrier, assault ships, and/or assigned oilers. The ASW mission in a CSG/ESG, therefore, is purely defensive. In a SAG, however, the ASW mission is often the primary focus.

---

<sup>2</sup> United States General Accounting Office, *Evaluation of Navy's Anti-Submarine Warfare Assessment*, July 1999.



**Figure 4: Elements of a CSG and Their Respective Missions**

**Limitations:** SEA-8’s initial study found many limitations in today’s ASW weapons, sensors, and platforms, based largely because ASW was not considered a primary concern following the fall of the Soviet Union. With the disappearance of that ASW threat, emphasis was placed on other mission areas to counter more readily apparent threats. This lack of attention created an ASW research and development gap. These limitations also came about because the legacy systems in place today have been designed for “nuclear submarines engagements in the open ocean environment.”<sup>3</sup>

In recent years, many nations have opted to fortify their coastal waters as a cost effective alternative to raising an expensive navy, the thought being that while they can’t keep a first-rate navy from crossing the ocean, they can make the price of doing business in their own waters very high—high enough perhaps to prevent the US from conducting operations close to their homeland. This shoreward shift calls for new systems designed for littoral warfare.

Many potential peer and near-peer competitors have taken advantage of this American ASW “gap” and aggressively pursued advanced USW initiatives. A threat in “shallow water” requires a thorough understanding of “near shore oceanographic

<sup>3</sup> United States General Accounting Office, *Evaluation of Navy’s Anti-Submarine Warfare Assessment*, July 1999.

phenomena” and up-to-date knowledge on how the submarine has advanced technologically to operate quieter and more efficiently in that environment over time.

As seen in Figure 5, many nations throughout the world own submarines, and these submarines have increased capabilities, including “advanced diesel and Air Independent Propulsion (AIP) power plants.” With a potential battlespace that could be anywhere on the globe, the “uncertainties about our ability to contain the new and different undersea threat we face today” grows.<sup>4</sup> And, “while the number and capability of potential enemy submarines is lower, the value of today’s individual targets is high, they are fewer and faster: much more difficult to find and hit.”<sup>5</sup>

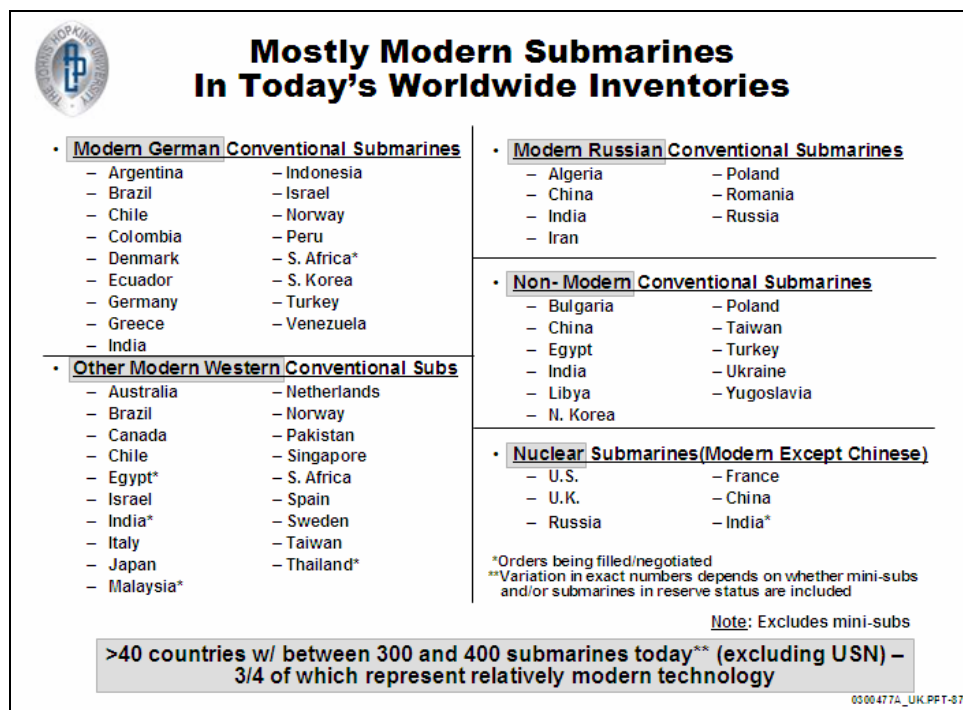


Figure 5: Submarine Assets by Country and Type<sup>6</sup>

Two major challenges rise out of the understanding of these changes in threat and operating environment. The first challenge has to do with how the Navy approaches the ASW problem. The most common belief is that the current approach is “inefficient” because the process is “sequential, asset intensive and require[s] operational pause

<sup>4</sup> Ibid.

<sup>5</sup> Rear Admiral William J. Holland, Jr., USN (Ret), “Offensive ASW—The Right Answer for the New Age,” *The Submarine Review*, January 2005, pp. 49-58.

<sup>6</sup> John R. Benedict, *Taking a Long-Term Perspective on US Navy ASW Objectives, Capabilities & Trends*, 12 January 2004 PowerPoint Presentation.

(sometimes lengthy) to prepare a limited area to support naval force operations with acceptable risk.”<sup>7</sup>

The second challenge has to do with training. Training can take place in the form of simulators (through the use of war games), or live operations and exercises at all levels. Practice provides the needed proficiency in operators and helps the user “see the challenges of the environment and tactics and the opportunities for exploitation.”<sup>8</sup> According to Vice Admiral John Morgan, USN, “We have not been able to practice ASW very realistically. Although our equipment has grown older and less effective, we have not noticed much impact, because the challenge has been so minimal.”<sup>9</sup>

Admiral Morgan delineates “three fundamental truths about ASW” that are worth mentioning:

- ASW is critically important to our strategy of sea control, power projection, and direct support to land campaigns
- ASW is a team sport, requiring a complex mosaic of diverse capabilities in a highly variable physical environment. No single ASW platform, system, or weapon will work all the time. We will need a spectrum of undersea, surface, airborne and space based systems to ensure that we maintain...full dimensional protection
- ASW is hard. The near shore regional/littoral operating environment poses a very challenging ASW problem<sup>10</sup>

As stated in the Naval Doctrine Command’s *Littoral Anti-Submarine Warfare Concept* paper:

...today’s ASW capabilities are optimized for open ocean environment. As the mission focus moves to the littorals, the typically harsher environment limits the technical performance of existing ASW tactical sensors and weapons, making it difficult to detect, localize, and neutralize submarines. Additionally, the lack of environmental data bases, remote and in situ sensors, real time tactical sensors and weapons performance assessments that can automatically adapt to changes in the environment

---

<sup>7</sup> Ibid.

<sup>8</sup> Rear Admiral William J. Holland, Jr., USN (Ret), “Offensive ASW—The Right Answer for the New Age,” *The Submarine Review*, January 2005, pp. 49-58.

<sup>9</sup> John Morgan, VADM, USN, *Anti-Submarine Warfare: A Phoenix for the Future*, 1998. Article downloaded from <http://www.chinfo.navy.mil/navpalib/cno/n87/usw/autumn98/anti.htm>.

<sup>10</sup> Ibid.



degrade an ASW commander's battlespace awareness and ability to achieve battlespace dominance in the force operation area.<sup>11</sup>

“The Cold War, deepwater legacy ...creates a solid foundation upon which to build the enhancements needed for effectiveness in the littoral, and new information processing technologies will help fill the remaining gap.”<sup>12</sup>

### ***2.1.2.1 Understanding the Littoral***

Sensors play a critical role in the ASW problem, especially in the littoral region. Effective littoral ASW operations require sensors that can easily adapt to different operational environments and carry out their mission with a high probability of success.<sup>13</sup>

Rear Admiral W.J. Holland, Jr., USN (Ret), in an article published in *The Submarine Review* in January 2005, states that one really needs to understand the “character of the ocean” where conflict is expected. This “character” includes such items as “sound velocity profiles, the effect of freshwater contributions, the diurnal variations, the character of the bottom, and similar conditions.”

Understanding the ocean in a surrounding conflict area helps the warfighter “determine the best depth to detect and avoid, the most likely locations for mines, the probable channels for dispersion and similar information.”<sup>14</sup>

From this information, we can further elaborate to classify the ocean into three distinct categories, each with their own unique set of challenges for ASW. The three categories are: (1) green water; (2) brown water; and (3) open ocean environments.

Green water is that area of the ocean shoreward of the continental shelf (and consists of) a mixture of drifting water bodies of different temperatures, salinities, and velocities that with shallow and turbulent conditions, limit sonar range. Limited sonar range is not the only challenge for ASW in green waters—shoals of fish, rocky outcrops, and wrecks that generate false contacts add even further to green water detection

---

<sup>11</sup> Naval Doctrine Command, *Littoral Anti-Submarine Warfare Concept*, 1 May 1998.

<sup>12</sup> Ibid.

<sup>13</sup> Ibid.

<sup>14</sup> Rear Admiral William J. Holland, Jr., USN (Ret), “Offensive ASW—The Right Answer for the New Age,” *The Submarine Review*, January 2005, pp. 49-58.

deficiencies. Because of these limitations, low frequency sonar lacks the precision needed, and active sonar gives [submarines] advanced warning.<sup>15</sup>

Brown water, on the other hand, ranges from the inland areas out to roughly 25 nautical miles (NM). Challenges for ASW in brown water are brought about through “currents, thermal disturbances, and winds [that] cause active sonar transmission to deflect downward, reducing effectiveness to a few hundred meters.” The challenge is further compounded with the addition of “industrial debris found offshore, and muddy conditions that degrade acoustic signals and make visual sightings impossible.” In addition, “outflow of cold freshwater from rivers flowing under sea water warmed by the sun create thermal layers that trap sonar signals in sound channels.”<sup>16</sup>

The open-ocean environment includes all ocean areas not classified as green waters or brown waters. In an open ocean, sonar ranges are more predictable, water characteristics are easier to understand and predict, and with the knowledge of just a few ocean characteristics (i.e., temperature, salinity, and currents), the detection range can be calculated with a higher degree of accuracy.

#### ***2.1.2.2 Defining Littoral for the “ASW in the Littorals” Problem***

Many competing definitions exist for the “ASW in the Littorals” problem. Naval Doctrine Publication -1 (NDP-1) defines littoral as “those regions relating to or existing on a shore or coastal region, within direct control of and vulnerable to the striking power of naval expeditionary forces.” For the purpose of this study, the term “littoral” encompasses ocean environments that extend from the shoreline out to 100 NM, which includes all three categories: brown waters of ports, rivers, and inland waters, the green waters of the coastal and near coastal environments, as well as the blue waters of the open ocean. This definition was derived from a compromise between the estimated power projection capabilities of both Red and Blue forces and the differing technological and architectural constraints that exist between open-ocean and near-shore operations. When extending the littoral region to a firm 100 NM, the resulting footprint includes potential political hotspots.

---

<sup>15</sup> Martin Edwards, “Anti-Submarine Warfare: New Scenarios,” global-defence.com, 2000, downloaded from <http://www.global-defence.com/2000/pages/antisub.html>.

<sup>16</sup> Ibid.

For illustrative purposes, consider the magnitude of this footprint on North America (Figure 6: left side); greater than 50% of the Gulf of Mexico is included by this definition. When considering Southeast Asia (Figure 6: right side), greater than 70% is included.

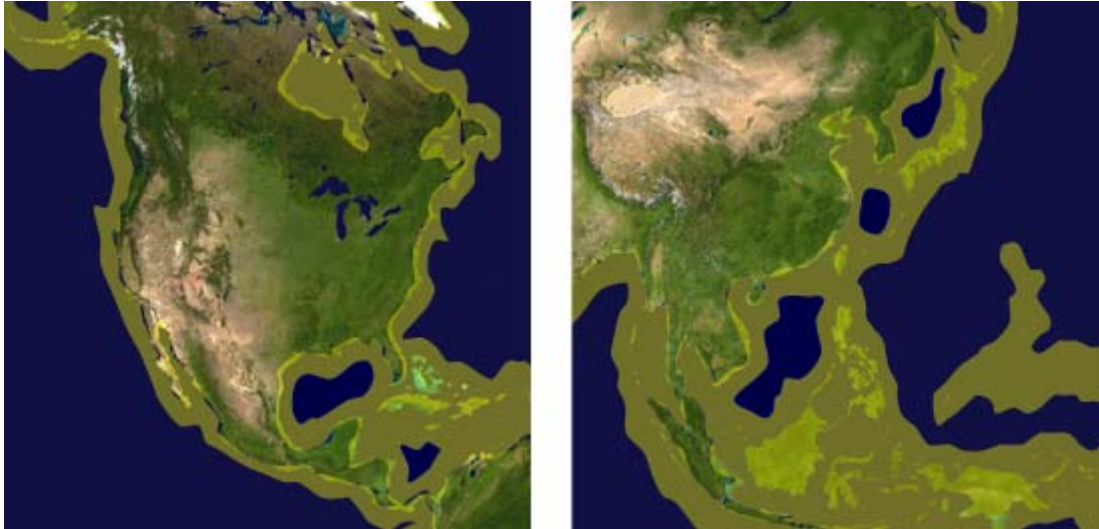


Figure 6: “The Littorals”

### ***2.1.2.3 Understanding Littoral ASW***

The principles of littoral ASW are as follows:

- Understand and prepare the battlespace for joint forces’ maneuvering upon the sea
- Deny enemy submarines influence in the joint operating area
- Prosecute enemy submarines as close to their operating bases as possible
- Emphasize integrated information connectivity and flexibility at all levels
- Adapt sensors and weapons to the operations environment to optimize results<sup>17</sup>

Littoral ASW operations must be effective because they (1) “enable Naval forces to project power ashore; (2) conduct strategic sealift operations; and (3) control or interdict sea lines of communication (SLOC) that affect littoral objectives.” These

---

<sup>17</sup> Naval Doctrine Command, *Littoral Anti-Submarine Warfare Concept*, 1 May 1998.

objectives encompass a mission of “forward operating battlespace dominance that directly supports the national military strategy (NMS).”<sup>18</sup>

In order for littoral ASW to be effective, several requirements exist. The first is that sensors must be able to adapt to the environment automatically. Second, numerous “coordinated” multiplatform assets will “ensure the most effective sensors and weapons are used when and where they are most needed.” And third, “continuous awareness of the common tactical picture among ASW assets”<sup>19</sup> will help the operational commander gain a balanced view of the problem and solution space.

By “knowing what submarines may be at sea, the geography involved and the availability and capability of various search sensors, analysts can develop efficient search patterns. Distributing this information transforms the ASW search from a random seeking out of potential intruders to a planned measure that narrows the location of probable contacts. Such tools make offensive ASW more efficient as well as more effective.”<sup>20</sup>

In warfare, commanders must be able to “balance the operational capabilities of available assets with mission objectives.” Operational capabilities can include everything from “combat systems and materiel, training, doctrine, organization, and leadership.” This balance, for littoral ASW, must also include understanding the environment and having in the asset list “environmentally adaptive sensors [that can be] used for cueing and targeting [in order to] find targets in an ambiguous battlespace environment.” The ability for these sensors to “overtly or covertly mark an adversary submarine and report locating data” is also important.<sup>21</sup>

According to the 1998 Naval Doctrine Command, *Littoral Anti-Submarine Warfare Concept*, the conduct of littoral ASW requires that US Naval forces be capable of performing the following:

- Detect, locate and target enemy submarines in littoral waters reliably
- Respond rapidly and decisively to enemy submarine contacts that may last only a moment (fleeting contact)

---

<sup>18</sup> Ibid.

<sup>19</sup> Ibid.

<sup>20</sup> Rear Admiral William J. Holland, Jr., USN (Ret), “Offensive ASW—The Right Answer for the New Age,” *The Submarine Review*, January 2005, pp. 49-58.

<sup>21</sup> Naval Doctrine Command, *Littoral Anti-Submarine Warfare Concept*, 1 May 1998.

- Employ integrated ASW systems (people, sensors, weapons, and communications) with very high probability of neutralizing the target
- Provide all commanders with a common tactical picture of the undersea battlespace

Current day systems and doctrine restrict today's ASW to platform-centric operations conducted as an enabling phase distinct from the main warfighting effort to prevent unacceptable losses to enemy submarines. Also, multiplatform littoral ASW is solely based on experiences and knowledge gained through open-ocean ASW. As improved equipment and updated tactics, techniques and procedures are developed, the state of ASW will evolve from a sequential, platform-centric reality of today to the concurrent network-centric construct of the future.<sup>22</sup>

#### ***2.1.2.4 Understanding ASW Operations in the 21st Century***

The “Anti-Submarine Warfare, Concept of Operations for the 21st Century” states that the Navy will meet the ASW challenge through “an integrated systems approach to fully exploit all joint mobility, sensors and weapons capabilities.”<sup>23</sup> The envisioned operating environment of the littorals will present increased challenges for the war-fighter. High traffic density, poor sound propagation, high technology enemies and asymmetric challenges will present difficult issues to be mitigated and subsequently overcome. Within the non-homogeneous littoral environment, understanding and adapting to a range of oceanographic conditions will be necessary. Critical environmental parameters include:

- Physical Parameters – waves, tides, currents, fresh water incursion from river outflows and eddies combine to create a noisy and dynamic environment in which a submarine will be quieter than the surrounding environment. A simple temperature profile will not be adequate to assess the oceanographic environment

---

<sup>22</sup> Ibid.

<sup>23</sup> Chief of Naval Operations, “Anti-Submarine Warfare, Concept of Operations,” 20 December 2005.

- Geospatial Parameters – the bathymetry, bottom composition, and nearby topography could be used by submarines to hide and complicate sensor performance predictions
- Biological Parameters – submarine movement activates bioluminescence in certain regions<sup>24</sup>

SEA-8's engineering design plan has identified major design steps, parameters, and analysis necessary to develop an array of deployment options which will support the ASW concept of operations (CONOPS) for the 21st Century and littoral USW in 2025. The deployment capability of this SoS will contribute significantly to the force attributes of persistence, pervasive awareness, speed, and operational agility and technological agility.<sup>25</sup> Successful usage of the SEDP should ensure that the deployment of a SoS will meet the needs of the stakeholders.

The long-term strategy necessary to exploit near-peer competitor technologies and tactical advances are outlined in the ASW CONOPS in two operational level objectives:

- Hold Enemy Forces at Risk: “We will deny enemy submarines an offensive capability by maintaining the ability to destroy them, if and when required, at a time and place of our choosing”<sup>26</sup>
- Secure Friendly Maneuver Area: “We will drive away or destroy enemy submarines, thereby protecting maritime operating areas. We will protect US and coalition combatants, support ships, and merchant shipping from undersea attack within and en route to vital operating areas”<sup>27</sup>

The ability to accomplish these two overarching objectives will be linked to the ability to have a SoS that is rapidly deployable, fully integrated, joint capable, and network centric. The SoS deployment capability will be in keeping with the Chief of Naval Operations' (CNO) SEAPOWER 21 initiatives of Sea Shield, Sea Strike, and Sea Basing.

---

<sup>24</sup> Naval Doctrine Command, *Littoral Anti-Submarine Warfare Concept*, 1 May 1998.

<sup>25</sup> Ibid.

<sup>26</sup> Ibid.

<sup>27</sup> Ibid.

### 2.1.3 Primitive Need

The US Navy is currently unmatched in maritime supremacy. Such supremacy grants today's warfighters the opportunity to look at the future threat environment and begin developing systems and network capabilities to maintain their comparative advantage. The current force structure of the US Navy was designed to meet a blue-water Soviet threat that no longer exists.

Throughout history, conflict on the open seas rarely had significant impact on a crisis unless it affected events ashore. Naval leadership and conventional wisdom indicate that the fleet must transform into a force that can affect events ashore with an immediacy and persistence not previously achieved. One aspect of this transformation requires tomorrow's Navy to effectively operate in the littoral environment. The littoral environment is challenging due to the ability of an adversary to conduct Anti-Access and Area-Denial campaigns from shore-based sites, while limiting exposure of their naval forces. The conduct of such a campaign in the littorals will likely be conducted with submarines, mines, and associated undersea force components.

The littoral environment is typically one of high traffic density and poor sound propagation that grant the "local" adversary's submarine fleet distinct advantages, such as the ability to hide in background noise. The advantage in the littoral environment must be mitigated by developing sensors, weapons, networks, and platforms that "hold enemy forces at risk" or simply deny the enemy the ability to complete their mission.<sup>28</sup>

SEA-8's primitive problem statement was to "develop a SoS architecture for the conduct of undersea warfare in the littorals in the 2025 time-frame."<sup>29</sup> The SoS is defined as alternate mixes of legacy and technology-driven future PORs that will leverage advances in order to provide future warfighters with the most effective means available to prevent the enemy from successfully employing undersea assets against friendly forces.

The primitive need statement is the original problem statement provided by the primary stakeholder. The original problem statement provided in the tasking letter details the following:

---

<sup>28</sup> ASW Concept of Operations for the 21st Century.

<sup>29</sup> Naval Postgraduate School, Meyer Institute of Systems Engineering (Unpublished Memorandum: 28 March 2005).

Develop a SoS architecture for the conduct of undersea warfare (USW) in the littorals in the 2025 time frame...selecting some or all of these capabilities for your system requirements: (a) Battlespace preparation and monitoring, (b) Persistent detection and cueing, (c) Combined arms prosecution, (d) High volume search and kill rates, (e) Non-traditional methods, and (f), Defense-in-depth.<sup>30</sup>

In order to specifically define the original problem statement, SEA-8 used a hybrid systems engineering process (as stated in “Team Structure” in Section 1.3). This system combines both the SEDP and the Systems Approach detailed in Eisner’s book on systems engineering<sup>31</sup> to ensure that the process remains both iterative and comprehensive.

SEA 8’s focus was directed toward pervasive awareness, speed, persistence, and technological agility to eliminate subsurface threats effectiveness. This thesis technical report is guided by the *Anti-Submarine Warfare Concept of Operations for the 21st Century* published by the United States Navy on 20 December 2004.

#### **2.1.4 System Decomposition**

System Decomposition is a tool used by systems engineers to break apart an existing system into the following sections based on:

- Functions
- Components
- Hierarchical structure
- States or conditions

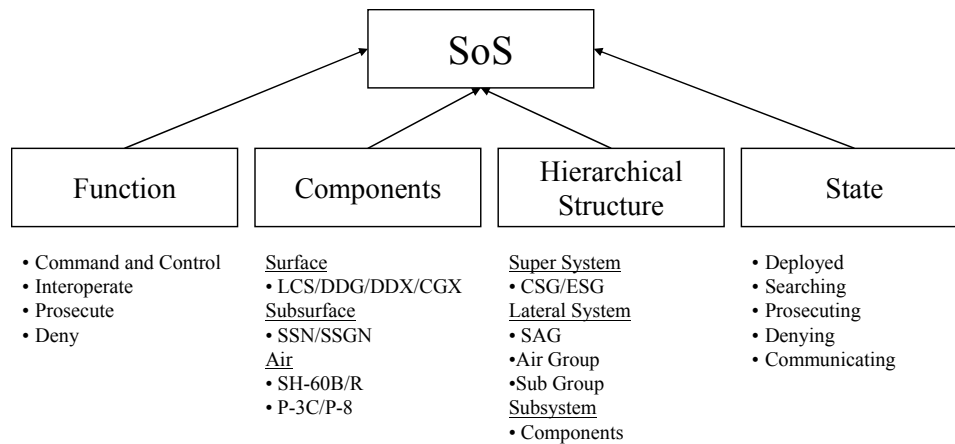
Figure 7 depicts the system decomposition break down for a typical ASW SAG. This process helps to better understand the relationships inherent in a SoS as well as to define the baseline system from which to model future alternatives.

---

<sup>30</sup> Meyer Institute of Systems Engineering *Memorandum for SEA8 Students*, Integrated Project Tasking Letter, 28 March 2005.

<sup>31</sup> Howard Eisner, *Essentials of Project and Systems Engineering Management*, Wiley Publishing, 2002.





**Figure 7: Current SAG System Decomposition**

Three current system configurations exist to support littoral USW missions for the US Navy: the ESG, the CSG,<sup>32</sup> and forward-deployed units. The ESG carries out missions similar to those of “an enhanced Amphibious Ready Group,”<sup>33</sup> and, although equipped with some assets to counter the perceived threat in the initial problem statement, this is not its primary mission.

SAGs are very capable of carrying out the mission as outlined in the initial problem statement. In fact, “surface combatants can provide protection of sea and air routes, ports, coastal airfields, and facilities and substantial command, control, and communications capabilities.”<sup>34</sup> While the SAG can be a system in itself, its composition is not arranged in a manner that makes it most effective in a littoral sea space.

As a major element of a carrier battle group, surface combatants provide the primary defensive capabilities for the group and contribute significant strike and fire support for joint operations ashore. Navy officials stated that one or more surface combatants are necessary at all times to escort and protect the aircraft carrier. Without them, an aircraft carrier could not safely deploy. Although the Navy has emphasized using its surface combatants more independently, they are still inherently linked to carrier force structure and deployments.<sup>35</sup>

<sup>32</sup> Sea Power 21 lists the groups of naval assets broken down by function, as the following: “12 carrier strike groups, 12 expeditionary strike groups, 9 strike and missile defense surface action groups, and 4 guided missile submarines that carry a SOF contingent.” This is found at [http://www.cadre.maxwell.af.mil/warfaresudies/wpc/wpc\\_txt/navy/units.htm](http://www.cadre.maxwell.af.mil/warfaresudies/wpc/wpc_txt/navy/units.htm).

<sup>33</sup> [http://www.cadre.maxwell.af.mil/warfaresudies/wpc/wpc\\_txt/navy/esg.htm](http://www.cadre.maxwell.af.mil/warfaresudies/wpc/wpc_txt/navy/esg.htm).

<sup>34</sup> <http://www.fas.org/man/dod-101/sys/ship/surface.htm>.

<sup>35</sup> Ibid.

#### **2.1.4.1 Function**

The CSG possesses a range of capabilities and is divided into action groups as threats arise. As part of their normal mission package, CSGs detach action groups to perform adequately in several areas, including littoral warfare, ASW, surface warfare, and air warfare, among others.<sup>36</sup> A SAG has the capability to search for mines to a small degree (SH-60 helicopters, P-3s). No sea-based organic mine warfare assets currently deploy with CSGs. Through the use of submarines that deploy with CSGs, the ability to protect sea approaches does exist. A SAG has the capability to deploy, search, detect, identify, classify, track, assess, and deny areas to enemy underwater forces to allow safe US/allied force operations. The top level functions of a SoS are:

- Command
- Deliver
- Prosecute
- Defeat

#### **2.1.4.2 Components**

Components are broken down into three general categories: structural, operating, and flow.

2.1.4.2.1 COMPONENTS, STRUCTURAL. Structural components are comprised of a CSG/ESG and forward-deployed units that will likely form a SAG. These are defined through Navy doctrine, and common operational practices, and can be augmented depending on the mission. The most common structural components of a typical SAG in 2005 are:<sup>37</sup>

- 2 Guided Missile Frigates (FFG)<sup>38</sup>

---

<sup>36</sup> “Sea Control is the sine qua non [an indispensable condition] for all Navy functions, missions, and endeavors. To get it and keep it requires large, fast ships, control of the air and sea, and strong antisubmarine and mine countermeasures forces.” (RADM William J. Holland, Jr., USN (Ret). “The Navy is Hauling More Than Marines,” *Proceedings*, May 2004, p. 38.

<sup>37</sup> [http://www.cadre.maxwell.af.mil/warfaresudies/wpc/wpc\\_txt/navy/csg.htm](http://www.cadre.maxwell.af.mil/warfaresudies/wpc/wpc_txt/navy/csg.htm)

<sup>38</sup> The carrier includes a carrier air wing, comprised of the following elements: 36 F/A-18s - Strike/Fighter, 14 F-14s - Fighter/Strike, 4 EA-6Bs - SEAD/Jamming, 4 E-2Cs - Airborne Warning and Control, 8 S-3Bs - Surface Warfare/Tanker, 6 SH/HH-60s - Undersea/Logistics/CSAR, and 2 C-2s - Carrier

- 1 Guided Missile Cruiser (CG) – Air warfare
- 1 Guided Missile Destroyer (DDG) – Surface and undersea warfare
- 1 Attack/Nuclear Submarine (SSN) – Surface and undersea warfare
- 4 ASW SH-60 Helicopters – Surface and undersea warfare
- 3 Maritime Patrol Aircraft (MPA) – Surface and undersea warfare

Structural components are divided up as follows:

- Air units, MPA, and SH-60 helicopters that are on guided missile cruisers, destroyers, and frigates
- Surface units. Surface units include the aircraft carrier, in addition to cruisers, destroyers, and frigates
- Subsurface units (submarines)

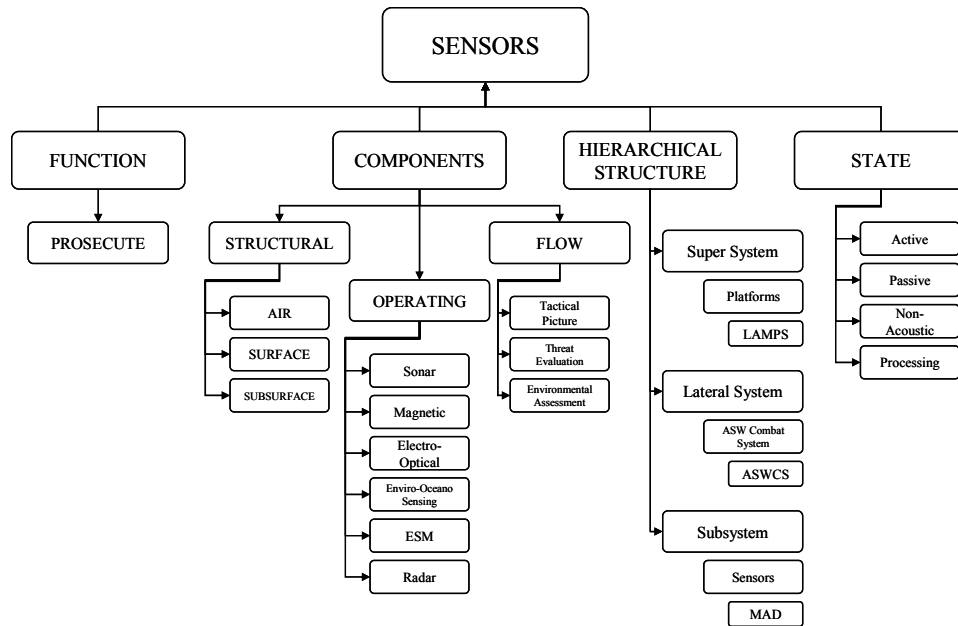
Capabilities of the current ASW systems were designed to function largely in an “open ocean ASW” environment rather than in the littoral region.<sup>39</sup> “The reliance today is to “disburse a number of multi-mission platforms over the same area,” even though it may be more “practical to distribute large numbers of ASW sensors.”<sup>40</sup> Figure 8 illustrates the system decomposition for those “sensors” associated with ASW, to include the function, components, hierarchical structure, and state.

---

onboard delivery. John R. Benedict, *Taking a Long-Term Perspective on U.S. Navy ASW Objectives, Capabilities & Trends*, 12 January 2004, PowerPoint presentation.

<sup>39</sup> “Most current ASW systems were designed during the Cold War to pursue nuclear submarines operating in the open-ocean environment.” United States General Accounting Office, *Defense Acquisitions: Evaluation of Navy’s Anti-Submarine Warfare Assessment*, July 1999, p. 2.

<sup>40</sup> John R. Benedict, Jr., “Future Undersea Warfare Prospectives,” *John Hopkins Applied Physics Laboratory Technical Digest*, Vol. 21, No. 2 (2000), p. 274.

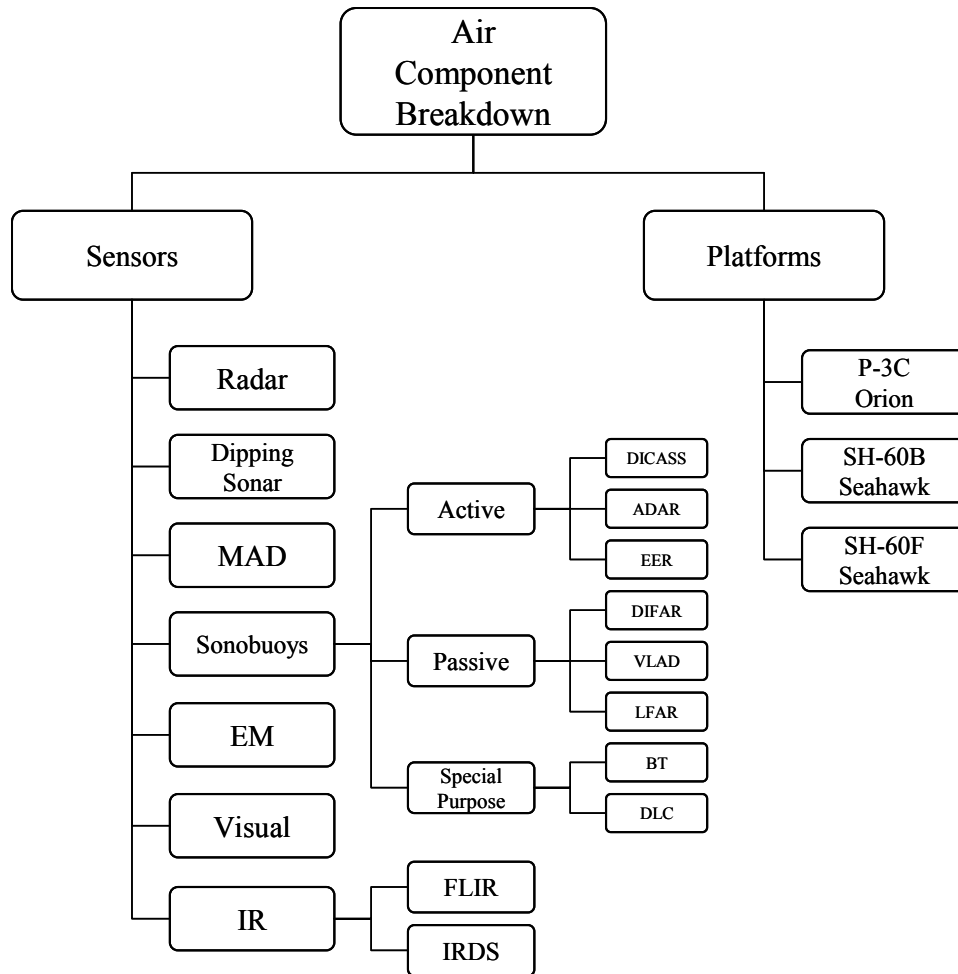


**Figure 8: System Decomposition Diagram for Sensors**

For Prosecution, sensor components are broken down into three main categories: *air*, *surface*, and *subsurface*. Each component has a unique set of sensors and platforms that are currently being used to solve the ASW problem. While the sensors themselves cannot be combined, their respective combat systems that monitor the input of the sensors combine these sensors' inputs to form a common tactical picture.

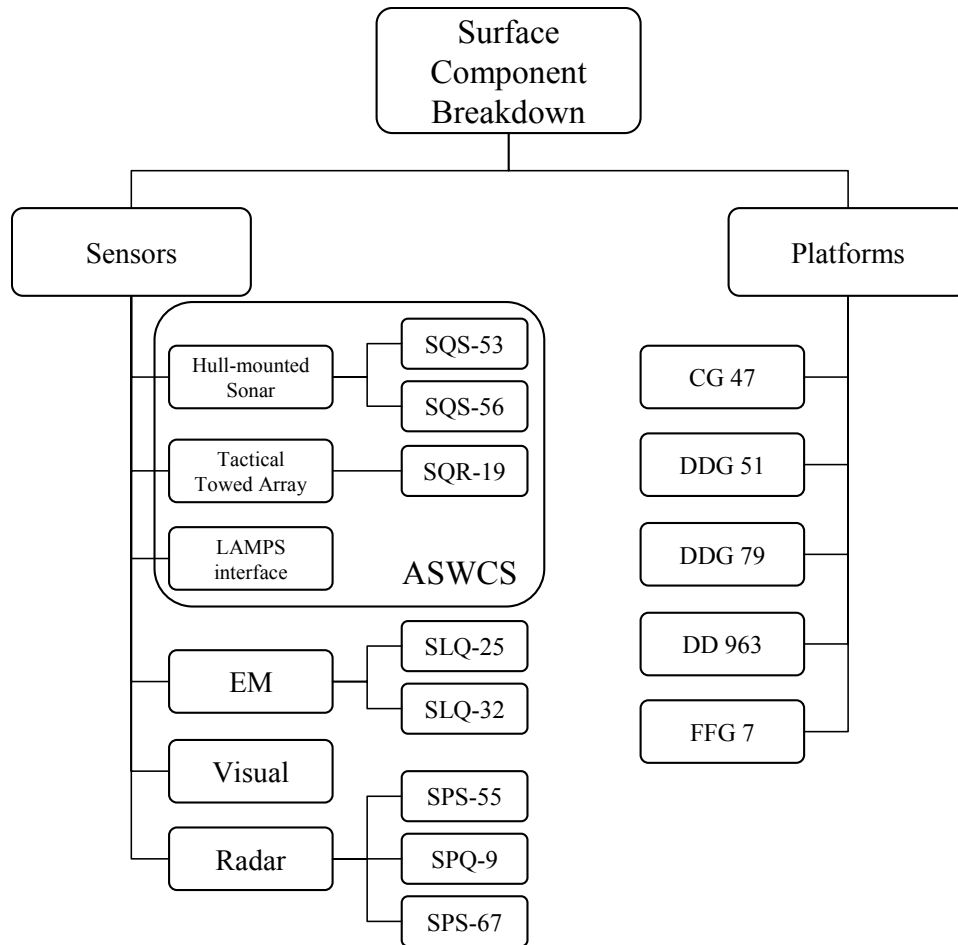
The “air” component is broken down into sensors and platforms. While a sensor may have limited reach (largely based on power output and operating environment), their reach is further extended by the platform to which they are attached. This makes the air component of the ASW problem a tremendous asset. Sensors that can be found in the air component include the Magnetic Anomaly Detection (MAD), Dipping Sonar, and Sonobuoys, in addition to Electro-Magnetic (EM) and Infrared (IR). Radar systems also play a key role in submarine mast detection.

Platforms that carry these sensors and communicate their findings to the respective combat systems for processing include the SH-60B/F Seahawk helicopter (organic to surface ships, Light Airborne Multi-Purpose System [LAMPS] component), and the P-3C Orion (land-based air component). Figure 9 displays this breakdown in detail, and the explanation of each major sensor and their capabilities can be found in Section 3.3.3.1.



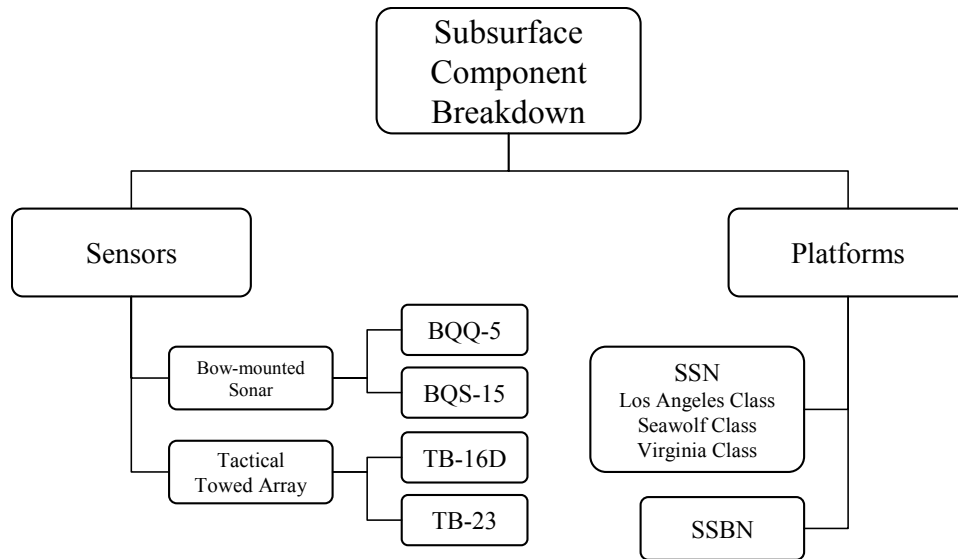
**Figure 9: Air Component Breakdown Chart**

The “surface” component for underwater detection includes the ASW Combat System (ASWCS) suite that comprises a tactical sonar suite to include the hull-mounted sonar and the towed array sonar or multifunction towed array (MFTA). The ASWCS is also integrated with the LAMPS sonobuoy processing system. Figure 10 displays the surface sensors breakdown in detail, and the explanation of each major sensor and their capabilities can be found in Section 3.3.3.2.



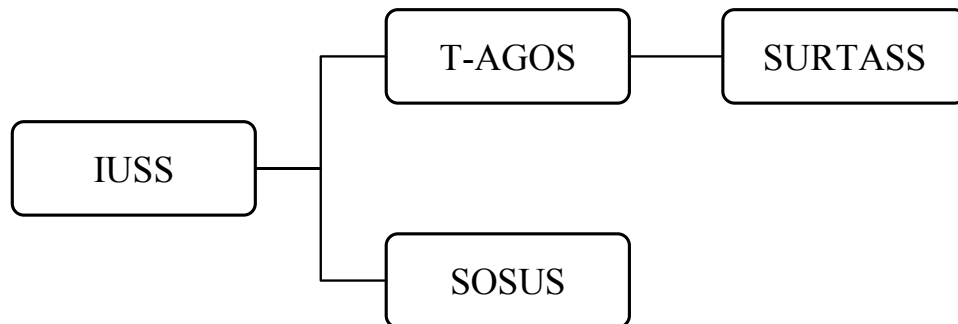
**Figure 10: ASW Surface Component Breakdown**

Like the surface platforms, submarines also have towed arrays and hull-mounted sonar suites. Submarines are equipped with “thin line” and “fat line” towed arrays, a wide aperture flank array, low frequency sonar arrays, and close range active sonars for detection of mines and ice. Figure 11 illustrates this breakdown in detail, and the explanation of each major sensor and their capabilities can be found in Section 3.3.3.3.



**Figure 11: Subsurface Sensors Breakdown**

Besides the sensors listed for air, surface, and subsurface above, the US Navy also manages an Integrated Undersea Surveillance System (IUSS). This system is comprised of both a towed-array component called the Surveillance Towed-Array Sensor System, or SURTASS, towed by surveillance vessels or T-AGOS ships; and a static component called the Sound Surveillance System, or SOSUS. Figure 12 illustrates the components of the IUSS.



**Figure 12: IUSS Components**

Command and communication components exist primarily as the infrastructure required in order to conduct the ASW C4ISR mission. They consist of shore-based infrastructure (i.e., shore-based communications facilities, central processing facilities, and national repositories of information), sea-based infrastructure (i.e., aircraft, ships, and submarines (manned and unmanned)) and space-based infrastructure in the form of intelligence and communications satellites. All of these components can be

further broken down into structural subcomponents that include the equipment required to transmit and receive data such as antennas, receivers, transistors, and computer hardware, etc. For the purpose of this chapter, analysis will remain at the macro level.

2.1.4.2.2 COMPONENTS, OPERATING. Operating components are the actual components that perform the processing. In a SAG, the operating components vary and can include the following:

- Shore installations that provide services (mail, food, fuel, training, etc.) and maintenance
- Pier-side service equipment that assist with repairs, provide supplies, etc.
- Power plants that provide the energy necessary for the structural components to operate

From the prosecution standpoint, operating components include all sensors that are used to prosecute a submarine (limited to what exists and is in use today). While these sensors are normally classified by the platform they reside on or are most often used with, the POR shows various sensors in development and those are detailed in Sections 3.3.3.1 through 3.3.3.3.

Additionally, these components exist to do the work required to achieve the desired transformation process. In this case, the requirement is the transformation of raw data into useful information in order to achieve success in the ASW environment.

This transformation process must convey an understanding of the ASW environment including data from all participants, sensors, weapons, and intelligence in order for a complete picture to be established to facilitate the Anti-Submarine Warfare Commander's (ASWC) intent. In addition, the system must be able to convey the ASWC's intent to all participants based on the commander's understanding of the ASW environment, and facilitate correct understanding of that intent so that participants take correct action at the appropriate time.

Ultimately, command responsibility resides with the President of the United States and flows down through the chain of command to the ASWC and on to the operators at the controls of sensor and weapons' consoles. It is through this



transformation process that raw information is interpreted, conveyed, and understood by all participants allowing for successful ASW operations.

2.1.3.2.3 COMPONENTS, FLOW. Flow components are the elements that process changes. Included are the following components that are found on each of the surface and subsurface ships and some aircraft:

- Weapons
- Food
- Fuel
- Water
- Consumables

Prosecution discovered that flow components consist primarily of the *tactical picture*, *threat evaluation*, and *environmental assessment*. All three of these components will be evaluated in the modeling phase and take the center stage for further analysis and research. Understanding the environment becomes key to predicting transmission loss in the sonar equation. In addition, having an up-to-date threat evaluation and tactical picture provided by sensors is key for a commander's accurate assessment of the battlespace.

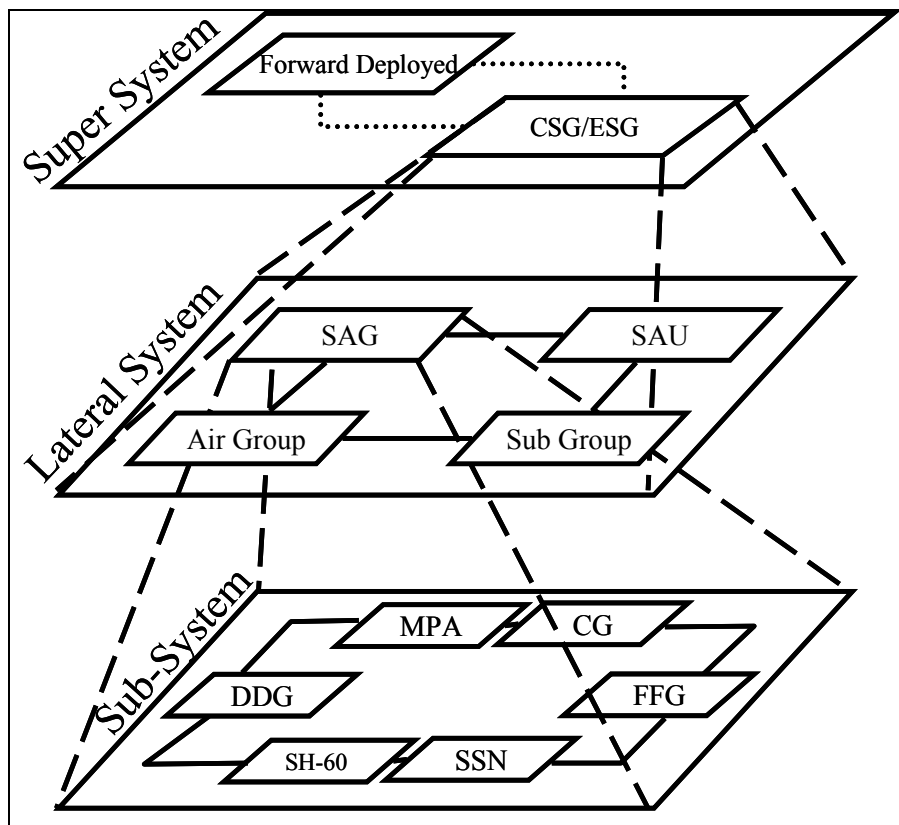
From a C4ISR perspective, the flow process is the conveyance of information received from subsystems, many located in the physical underwater environment, transformed into data that is able to be processed by other systems, transformed into knowledge by operators and technicians, then transformed again into understanding by decision makers. This flow of information from raw data to understanding is the key to successful ASW. The speed and accuracy with which this transformational process takes place determines, more than any other factor, success or failure.

#### ***2.1.4.3 Hierarchical Structure***

The Hierarchical Structure describes the big picture. Developing a hierarchical structure allows the system engineer to look up (for super systems), down (for subsystems), and sideways (for lateral systems) to better understand what

components are part of the same system, what parts are subordinate, and what parts are superior.

In the case of a forward-deployed ASW SAG SoS, the super systems comprise the forward-deployed CSG/ESG construct. A SoS is assembled from forward-deployed forces and the CSG/ESG-deployed units. Laterally, an Air Group is part of the super system configuration. Subsystems include all of the major components of a SAG, mainly the surface ships (CG, DDG, Spruance Class Destroyers [DD], FFG), SSN, MPA, and SH-60s that are organic to the surface unit force. The hierarchical structure of a notional ASW SAG is depicted in Figure 13.



**Figure 13: Hierarchical Structure of a Littoral Action Group**

From the C4ISR perspective, a system can be described in a hierarchical structure by defining the relationships between components. This allows for analysis of the holistic picture from the macro to the micro. Often, a super system is referred to as a SoS, a means of describing the many layers of complex components, each comprised of multiple subsystems. This is the case with a littoral ASW C4ISR system, where ASW is a single mission area within the greater core competencies of the US Navy. This means that

any ASW C4ISR system works alongside, or feeds into, other C2 systems, all feeding greater naval and national C4ISR systems. To better understand these relationships, a systems hierarchy was constructed to highlight those super systems, lateral systems, and subsystems which are described below:

- Super-system – National and naval C4ISR systems that integrate strategic- and operational-level information for decision makers
- Lateral-system – Operational- and tactical-level C4ISR systems that integrate information other than ASW information
- Subsystems – The many individual systems that make up the greater ASW C4ISR SoS

#### ***2.1.4.4 State***

States of the system indicate the systems modes, such as on or off, deployed or fixed in a theater, etc. Defining systems for the components helps the analyst understand the many functions a component provides in the operation. The states of the SoS are:

- While deployed, a SoS can be formed from CSG/ESG units and forward-deployed assets
- While in the search state, the SoS can be searching, controlling aircraft, and coordinating and exchanging C2 data
- While prosecuting, a SoS is actively or passively processing and evaluating a threat
- While denying, a SoS is actively controlling, sanitizing, deterring, or engaging an evaluated enemy underwater unit
- While communicating, a SoS is transmitting, receiving, or has the transmission equipment secured

The states that ASW prosecution assets can “sense” in are detailed at the end of Figure 14. These are active and passive acoustic states, nonacoustic states, and processing. Active and passive sensors evaluate sound under water, while nonacoustic sensors evaluate a contact picture with radar return, MAD, and various satellite and visual means. Processing is inherent in any system, and the processing rate becomes key

for how long it takes a combat system to evaluate the signal and determine if that signal represents a threat or not. Figure 14 shows various states in the sensor's arena.

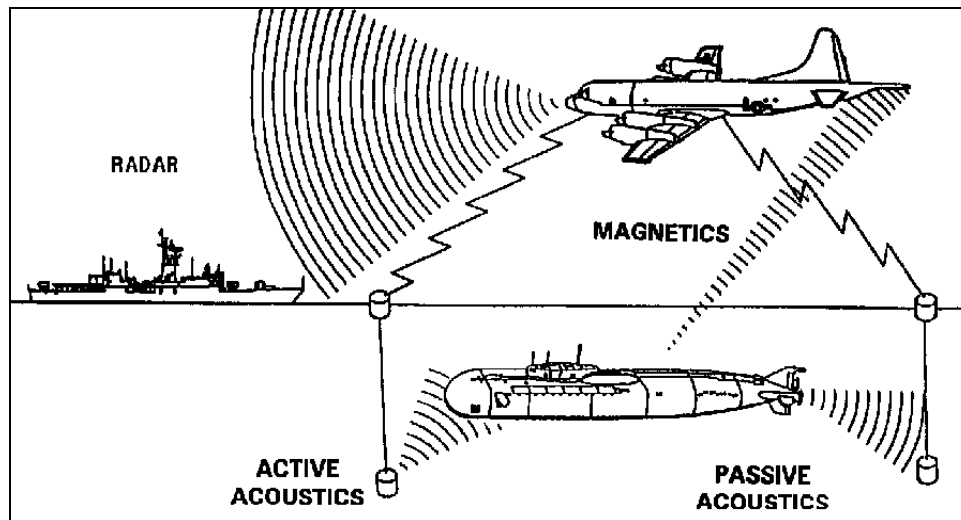


Figure 14: Display of Different States for Sensors<sup>41</sup>

The components of a system, or the system as a whole, can take on different qualitative or quantitative values to describe the current state of the system. As the C4ISR system deals in the management of information, the system can be said to be “in operation” (i.e., broadcasting and receiving), “secured” (i.e., not broadcasting or receiving), or operating in a “reduced/restricted” mode. This is overly simplistic and not a realistic description of how a C4ISR system operates, but it illustrates the basic operation of the system and is useful in decomposition analysis.

In reality, the ASW portion of a platform's combat systems suite may be secured, in port for example, or in full operation when hunting for a submarine. This assumes that these systems operate in a vacuum and are independent of other war fighting and communication systems—a false assumption, but one that is made for simplification.

**Operational Condition:** This is used to describe the degree to which a platform or unit is ready for combat operations. In the case of the ASW C4ISR suite, it describes the level of readiness of the overall ASW system on a unit level.

- Condition I – Generally, this means that a platform or unit is engaged in, or about to become engaged in, combat. All systems, including the ASW C4ISR systems, will be manned, ready and fully operational (barring any

<sup>41</sup> <http://sonobuoy.crane.navy.mil/SENSORS.HTM>, (accessed 3 November 2005).

maintenance deficiencies)

- Condition II – Applies to portions of a platform or unit that are ready for combat. For our system, Condition II (ASW) would mean that all ASW systems were fully operational even if the rest of a platform's combat systems were set to another condition
- Condition III – Normal peacetime underway steaming. ASW C4ISR system may be on in a reduced or training mode, or may be secured altogether
- Condition IV – In port/secured. ASW C4ISR is off-line at the unit or platform level, along with the rest of the combat systems on board

**Information Operations Condition (INFOCON):** Used to describe the intentional flow of information, generally unclassified, allowed through communications systems.

- INFOCON Normal – No information warfare attack anticipated and information (tactical and nontactical) is allowed to flow freely
- INFOCON Alpha – A heightened state or security for information flowing through the system information systems. All information is still allowed to flow
- INFOCON Bravo – An intentional restriction in the amount of flow on information systems due to the possibility of an attack. General traffic, information of non-tactical nature may be reduced or secured
- INFOCON Delta – Indicated that an information warfare attack is eminent; all information to/from a unit or platform is official only; and all nonessential information is secured. In this case, ASW C4ISR systems would still be operational, but nonofficial channels of communication (i.e., e-mail, Sailor-Phone – Voice Over Internet Protocol (VoIP)) may be secured

**Emission Control (EMCON):** Used to describe the intentional restriction in the use of radio transmissions. An enemy can intercept radio frequency (RF) energy and use it to locate friendly platforms or decipher the broadcast to understand the

communications traffic. For this reason, it is sometimes necessary to reduce, or secure, certain types of communications.

- EMCON Alpha – Silent, no RF communications
- EMCON Bravo – No unique emissions, limited communication
- EMCON Charlie – Unrestricted RF communication. In all cases other than EMCON Charlie, ASW C4ISR systems will be limited in their ability to transmit and receive data
- EMCON Delta – Restricted

**Other:** In the State cases listed above, information was intentionally restricted as a means of self-protection. There are other cases where information is unintentionally restricted.

- Range – The distance from a transmitter to a receiver may exceed the ability to receive data. This is of particular concern in ASW since underwater physics preclude much of the ability to transmit and receive data at tactically useful rates over a given range
- Jamming – An enemy force may have the ability to jam communications frequencies making communications difficult or impossible
- Bandwidth Restrictions – Many communications' circuits today are at their capacity, therefore, any additional information is unable to be processed by a system. This is of particular concern to satellite communication circuits on smaller platforms

### **2.1.5 Stakeholder Analysis**

Analysis of stakeholders is the second step in identifying the effective need when applying the systems engineering process. Identifying stakeholders is a key step in enabling the systems engineer to define who is going to help determine the system requirements, scope and bound the problem, and be involved in the entire process of definition, development, and deployment of the solution. Stakeholder analysis has several substeps that include: (1) identifying stakeholders; (2) identifying stakeholders' needs, wants, and desires; (3) conducting interviews with stakeholders; and (4) consolidating information.

Stakeholders can be broken down into five major categories. Each category identifies a unique function that the specific stakeholders in that category provide the systems engineer or the analyst team. These five categories are:

1. Decision Maker
2. Clients
3. Sponsors
4. Users
5. Analysts

The future system's purpose includes the security of US maritime assets. Alternative solutions considered will require assets currently in the US Navy. Therefore, the practical primary decision maker is the CNO.

Clients are offices or groups of people that will have substantial input as to the development of the solution set. They consist of the following:

- North Atlantic Treaty Organization (NATO)
- Combatant Commanders (COCOM)
- Department of Homeland Security (DHS)
- Naval Intelligence Community, known as N2

Sponsors are offices or groups of people that provide financial support, which may include technical support or support in the form of special studies or specialized information, and consist of the following:

- Program Executive Office (PEO)
- Type Commanders (TYCOM)
- Department of Defense (DOD)
- Department of Transportation (DOT)
- DHS
- Congress
- Integrated Warfare Systems (IWS)

Users are offices or groups of people that will actually use the system that is developed. Practical users include:

- Operators (COCOM, NATO, Fleet Commanders [FLTCDR], Surface Warfare Officers [SWO], Submariners, MPA Personnel, Special Operations Forces [SOF], Explosive Ordnance Disposal [EOD], Sailors)
- Contractors (Defense Contractors)
- Fleet ASW Command

Finally, analysts will evaluate the effective need and assist in determining the projected performance of various system alternatives. These include the following:

- SEA-8 Design Team
- Others (Naval Operations [OPNAV], Surface Warfare Development Group [SWDG], Naval Undersea Warfare Center [NUWC], Command, Naval Education and Training [CNET], Halsey Group, Command, Operational Testing and Evaluation Forces [COMOPTEVFOR], and Task Force ASW)

The stakeholders above defined their “needs, wants, and desires” for ASW as follows:

Sponsors have the following needs, wants, and desires:<sup>42</sup>

- Security of global shipping and maritime assets
- Rapidly deployable system
- Adaptable
- Share common picture
- Integration with current platforms

Clients have the following needs, wants, and desires:

- Unrestricted waterways
- Safe passage
- Freedom of navigation
- Environment free of obstructions and threats

---

<sup>42</sup> Most of these “needs, wants, and desires” can be found in the US Navy’s Sea Power 21 vision, such as the following: “Weapons, sensors, and communications systems with revolutionary reach and precision will integrate maritime forces into a unified battlespace extending across sea, land, air, space, and cyberspace—providing invaluable strategic and operational advantage from the vast international domain of the world’s oceans.” Extracted from Charles Moore, Jr., VADM, USN, et al., “Sea Basing, Operational Independence for a New Century,” *Proceedings*, January 2003.



Users have the following needs, wants, and desires:

- Search, detect, track, identify, engage, and sanitize localized areas
- Encrypted, hardened, and survivable system
- Easy to maintain, use, and train

Many of the expectations stem from the “recognition of the ability of much smaller States to deny access to their littorals with a few submarines or mines.”<sup>43</sup>

Task Force ASW lists what the future operating environment is speculated to be:

The 21<sup>st</sup> century environment is one of increasing challenges, due to the littoral environment in which we operate and advanced technologies that are proliferating around the world. Operations in the future will be centered on dominating near-land combat, rapidly achieving area control despite difficult sound propagation profiles and dense surface traffic. The operating environment will be cluttered and chaotic, and defeating stealthy enemies will be an exceptional challenge.

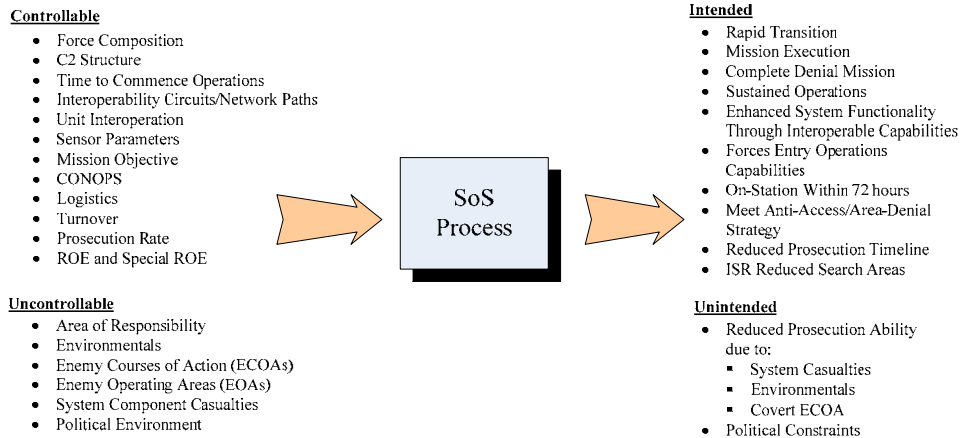
With these stakeholders’ input, SEA-8 designed a SoS.

### **2.1.5 Input-Output Modeling**

SEDP transforms the stakeholder’s requirements and needs into a set of system functions and process descriptions that generate information for the decision makers and provide input for the next level of functional development. SEDP is applied incrementally, adding additional details and definitions with each level of development. The system process includes: Controllable and Uncontrollable Inputs, and Intended and By-Product Outputs, as shown in Figure 15.

---

<sup>43</sup> Captain James A. Patton, Jr., USN, (Ret), “ASW is Back,” *Proceedings*, February 2004, p. 55.



**Figure 15: Generic Input-Output Model**

The Input-Output (I-O) Model for a littoral USW problem is critical to ensuring the end-product is flexible and responsive to any operating environment in which the end-product may be used. The I-O Model is a tool to help the analyst scope and bound the problem.

The first consideration when attempting to characterize the system with an I-O Model is to determine the intended outputs. In order for the 2025 littoral USW problem to be solved, the final solution must be able to meet a myriad of requirements, ranging from a product that is easily deployable to one that denies enemy ability.

The systems engineering process inputs combine the customer’s requirements and the project constraints. The controllable inputs tell what is needed to start the process in order for the outputs to be achieved. The controllable inputs, to meet the USW challenge, must be able to shorten the “Observe, Orient, Decide, Act” (OODA) cycle by having the capability to reach station within three days, short launch and recover times, high track quality, fast and accurate search rates, high data transfer rates (bandwidth and baud rate dependent), and long dwell times once on station. Controllable inputs apply to areas that can be controlled by the human interface into the system. These include, but are not limited to, training, C2, and the type, number, placement, and grouping of sensors for a specific operation, in addition to tactics and logistics. All of these areas play a key role in the inputs into the SoS and can make an operation succeed or fail.

Uncontrollable inputs are those mostly environmental characteristics that influence the performance of the system. They are inevitable factors such as geography,

climate, and topography. The uncontrollable inputs of our system often detract from the intended outputs. The answer to the USW challenge must be able to operate in such diverse littoral environments such as the shallow waters of the island nation strait to the deep-sea trenches located off a wide, unconstrained coastline. It must also be able to adapt quickly to the rapidly changing and harsh weather often found in the North Atlantic.

By-products of the systems process are unintentional or incidental outputs that have a positive or negative effect on achieving the overall goal of the system. Some of the by-products that have been identified by the team include such things as sensor failure and enemy responses. The I-O Model helps provide information on the performance characteristics of the system and relates to how well the system will work in its intended environment. Once the outputs have been generated and bounded, the analysts can begin to make a determination of the effective need of the client and goals that satisfy this need.

### **2.1.7 Effective Need**

In Section 2.1.2, SEA-8 delineated the stakeholders' primitive need assigned in the initial problem statement. Via careful analysis, system decomposition, I-O modeling, and interviews with stakeholders, the effective needs statement for the system process was found to be:

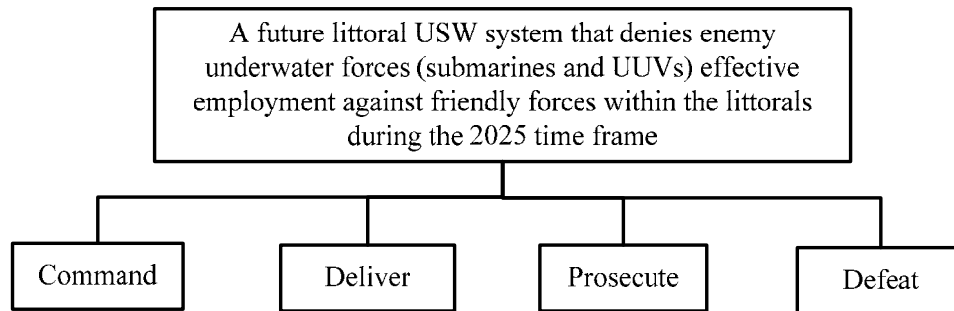
*Design a future littoral undersea warfare system that denies enemy Under Water Forces (submarines and UUVs) effective employment against friendly forces within the littorals during the 2025 time frame.*

From this statement, system requirements can be generated as part of the next step in the system process—functional analysis.

### **2.1.8 Functional Analysis**

The primary aim of the functional hierarchy, shown in Figure 16, is to act as a tool in the systems engineering management of the overall system design process. It is a representation of which components the system encompasses and provides a frame of reference to ensure the top-level functions and the sub-level functions meet the needs of

the stakeholders. By defining the system in functional terms and then decomposing the top-level functions into subfunctions, the problem can be bounded.



**Figure 16: Overall Functional Hierarchy**

The systems requirements are statements of fact and assumptions that define the expectations of the system in terms of mission objectives, environment, constraints, and measures of effectiveness (MOE). These parameters help define the system’s basic need, and are fundamental actions for operational success.<sup>44</sup>

To help codify the expectations of the system, a functional hierarchy and flow diagram must be established to ensure all requirements are examined appropriately. Functional requirements were identified, through functional analysis, to be the top-level functions.

The top-level functions of the functional hierarchy for the SoS challenge are Command, Deliver, Prosecute, and Defeat. During analysis, how well each attribute performs individually, as well as how it interacts across all identifiable top-level functions must be determined. If the SoS solution cannot meet these top-level functions, then the system will not be able to meet any subcategories that flow from the top-level functions in question. The extent to which overall mission objectives must be executed can be generally measured in terms of quantity, quality, area coverage, timeliness, and readiness posture. All system attributes, wants, needs, and desires have been characterized in terms of the degree of certainty in their estimate, the degree of criticality to system success, and relationships to other requirements. To ensure the functional hierarchy is correctly displayed, a functional decomposition must be performed.

---

<sup>44</sup> Andrew R. Sage and James E. Armstrong, *Introduction to Systems Engineering*, John Wiley & Sons, Inc., New York, 2000, p. 144.

### ***2.1.8.1 Command Functional Analysis***

To support functional analysis for an ASW C4ISR SoS, a specific Command effective need must be generated from the overall SoS effective need. From the C4ISR SoS requirements document and needs analysis, the C4ISR SoS shall:

- Facilitate Commander's (CDR) intent
- Be adaptable to varying situations
- Support information process requirements
- Exploit ASW force capabilities
- Support ASW force effectiveness

To determine an accurate and specific Command effective need statement, the overall SoS effective need statement below is used:

*A future littoral USW system that denies enemy Under Water Forces (submarines and UUVs) effective employment against friendly forces within the littorals during the 2025 time frame.*

The derived Command effective need statement reflects the overall SoS needs, the C4ISR SoS requirements, and C4ISR SoS analysis, and is stated as:

*A future C4ISR SoS that supports ASW effectiveness and exploits force capabilities above and below the sea to deliver commander's intent, tactical data, and intelligence to reduce overall SoS prosecution effort and timeline for defeat.*

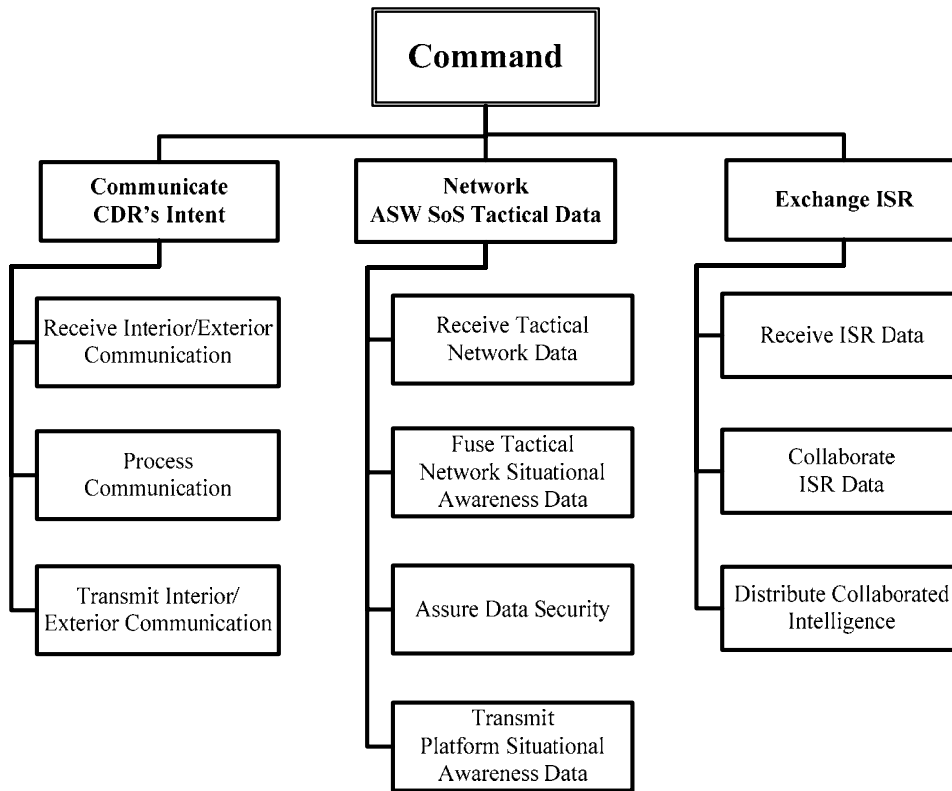
The primary aim of the functional hierarchy is to act as a tool in the SoS design process. It is a representation of which components the system encompasses and provides a frame of reference to ensure the subfunctions meet the system needs and requirements. The systems requirements are statements of fact and assumptions that define the expectations of the system in terms of mission objectives, environment, constraints, and MOE. These operational parameters defined for the system's basic need, at a minimum, and are necessary actions that must be accomplished.<sup>45</sup>

---

<sup>45</sup> Andrew R. Sage and James E. Armstrong, Introduction to Systems Engineering, John Wiley & Sons, Inc., New York, 2000, p. 144.

Functional requirements were identified through functional analysis to be the top-level functions. In the case of C4ISR, the Command function is identified as the top-level function for the overall SoS functional hierarchy. The subfunctions for Command are Communicate CDR's Intent, Network ASW SoS Tactical Data, and Exchange ISR. The supporting subfunctions for Command are architectural functions. Current C4ISR system functions can be viewed from multiple perspectives. In order to design C4ISR architectures, the SoS needed to be addressed from an architectural framework perspective. For the purpose of this study, the C4ISR functions will consist of a communication architecture, an ASW tactical data network architecture, and a separate ISR architecture.

Additionally, each of the subfunctions is supported by respective functions that are necessary for C4ISR system operations. The architectural perspective of C4ISR system functional analysis becomes apparent as lower level subfunctions become specific to its respective subfunction or architecture. By acting as architectural functions, the subfunctions delineate the three critical architectures that are necessary for a C4ISR SoS. The three critical architectures of Communicate CDR's Intent, Network ASW SoS Tactical Data, and Exchange ISR separate voice communication from networking tactical data. Figure 17 illustrates the Command functional hierarchy and supports the C4ISR SoS effective need.

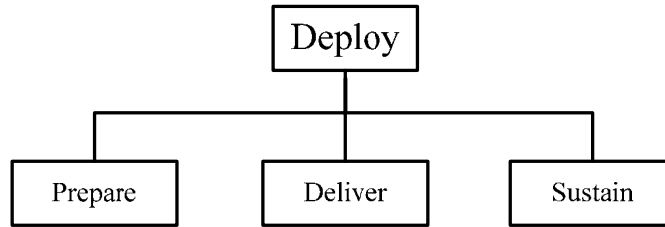


**Figure 17: C4ISR Functional Hierarchy**

Since the lower-level subfunctions support a specific architecture, respective functions differ across the hierarchy as architecture functions differ to support the C4ISR Command functionality. For instance, process, fuse, and collaborate are all supporting lower-level subfunctions that are similar, but specific to their respective architecture.

### ***2.1.8.2 Deploy Functional Analysis***

The functional analysis for the Deployment Team helped identify specific tasks within the SoS. Figure 18 shows the key functions the Deploy portion within the SoS, in order to accomplish the needs, wants, and desires of the stakeholders, and their respective explanations follow the graph.



**Figure 18: Breakdown of Deployment Team’s Overall Functional Structure**

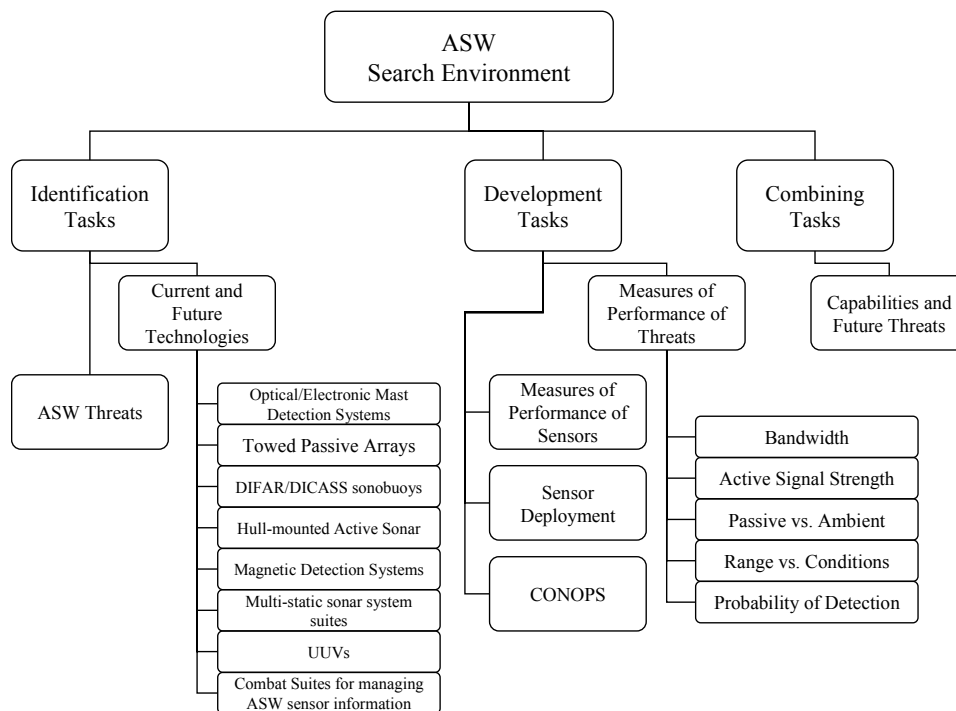
- Prepare
  - The ability to be equipped for rapid deployment via air, surface and subsurface assets external to the theater of operations
  - Sensor components requiring minimal maintenance and support requirements will ensure the highest readiness rate
  - Achieve capability to deploy self-initiating sensors which are ready for operations on deployment
- Deliver
  - Ability to interoperate with both legacy and future POR deployment systems. Modularity and interoperability will aid in development of the Common Undersea Picture (CUP)
  - Ability to provide the sensor assets required to provide a 0.5 Probability of detection (Pd) within 72 hours across a contested waterway
  - Ability to provide the sensor assets required to provide a 0.8 Pd within 10 days across a contested Area of Responsibility (AOR)
- Sustain
  - Ability to provide the logistical support necessary to sustain those assets already within the AOR for 20 additional days
  - Capability, through modular design, to be replenishable via a variety of joint methods
  - Ability to supply and/or deploy and organically support SoS components



- Ability to continue deployment of the full spectrum of SoS components to include UUV and distributed network sensors and components

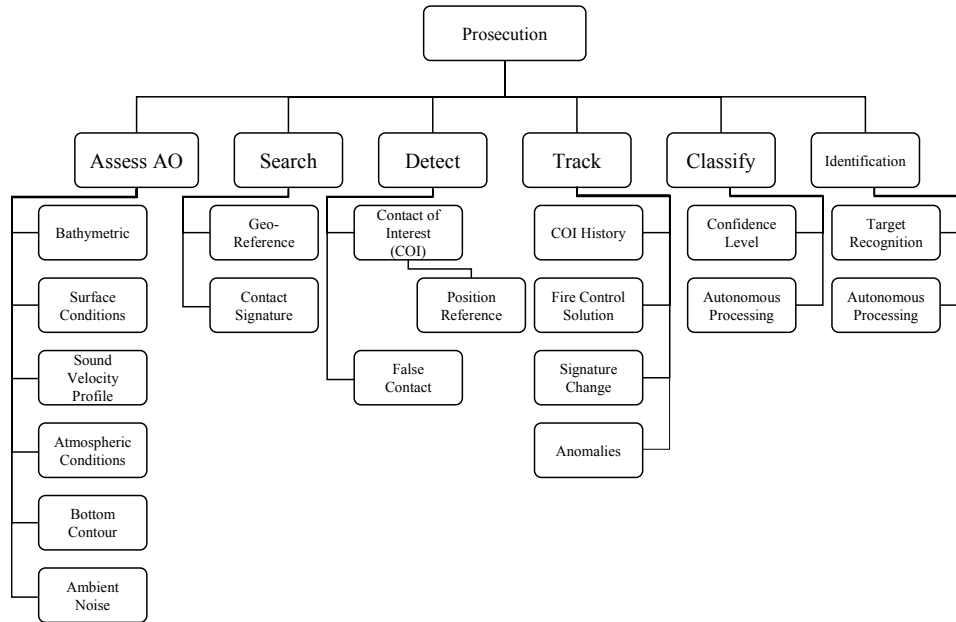
### 2.1.8.3 Prosecution Functional Analysis

The ASW Search environment encompasses several facets of today’s sea-going mission for the US Navy. As per Figure 19, the search environment can be broken down into three distinct tasks: identifying, developing, and finally, combining the tasks. The task of identifying a threat in the ASW problem is just that—determining that the threat is an ASW threat. Once a problem area has been identified as a threat, the Navy will isolate the location, determine its identity, and develop a fire control solution. All of this is done through the use of current ASW sensors and platforms. The Development Tasks help the user understand the functions of the respective sensors and assets in more depth, and how these assets interoperate with the environment, sound profiles, and other elements found in the sound equation. The Combining Tasks portion puts the current sensors and their functions and performance factors together, and with some analysis, finds ways to improve detection and localization.



**Figure 19: Overall Sensors Approach to the ASW Problem**

Functional decomposition takes the primary SoS function and breaks it down into subfunctions, objectives, and ends with metrics or MOEs. Initial functional analysis is represented in Figure 20, depicting the decomposition of sensors.

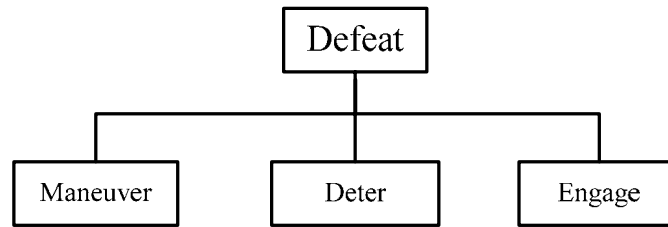


**Figure 20: Functional Decomposition of Prosecute including Key Concepts that will need to be addressed in the ASW Problem**

For the initial Functional Decomposition, the Sensors Team has broken down the “Prosecution” main function into six distinct subfunctions of assess, search, detect, track, classify, and identify. Figure 20 examines an initial amplification of each sub-function. For instance, under “track,” it is expected that this function encompasses maintaining a COI history, developing a fire control solution, managing contacts for signature changes, and developing criteria for anomalies. This same level of reasoning was applied to all of the six subfunctions listed above.

#### ***2.1.8.4 Defeat Functional Analysis***

The functions of the Platform Development Team (PDT) have been defined in the Functional Analysis portion of the SEA-8 Needs Analysis write-up. What follows is an initial examination as they pertain to other areas of the overall project. Figure 21 shows the PDT functions of this hierarchy under the overall PDT function of “Defeat.” In addition, definitions of each of these subfunctions are given.



**Figure 21: Breakdown of PDT's Overall Functional Structure**

- Maneuver
  - Use future energy storage and propulsion technologies to increase AOR coverage and time on station
- Deter
  - Show of force or presence to dissuade enemy opposition or movement. Overt actions taken to force or control enemy maneuvers. Establish tripwires and follow-on consequential actions that control enemy assets at a safe distance from allied forces.
- Engage
  - Neutralize or disrupt the enemy's ability to perform desired mission

These subfunctions define the boundaries of the PDT's area of interest.

As the iterative process of developing a system to meet the effective need of our stakeholders progressed, it was decided that both the functions of deterrence and engagement were beyond the scope of this project and would not be studied in detail. Additionally, the maneuver function and the objectives that followed were absorbed into the research and study by both the Prosecution and Deployment Teams.

#### ***2.1.8.5 Functional Flow***

During the functional decomposition of the new system, mapping the functions to physical components ensures each function has an acknowledged owner, meets the system's requirements, and guarantees all necessary tasks are listed so that no unnecessary tasks are generated. In order to determine the basis for the hierarchical structure, arrangement of the functions in a logical sequence, and decomposition of higher-level functions into lower-level functions, a tool called the functional flow block

diagram is required. The diagram shows not only the functions that have to be performed, but also the logical branching and sequencing of the functions and performance requirements associated with those functions.

Functions are discrete actions necessary to achieve the system’s objective. The branching and sequencing of the SoS requirements within a functional flow diagram is critical to solving the littoral USW problem. If the branching and sequencing is not done correctly, the SoS system will become rigid and unresponsive to the needs of the stakeholders. The functions of our system, for the littoral USW challenge, will ultimately be performed or accomplished through the use of equipment, personnel, sensors, logistical support, sustainability, and adaptability throughout the life cycle of the system and are shown in Figure 22. It is important to note that the Command function of the SoS system remains constant throughout the SoS system functional flow.

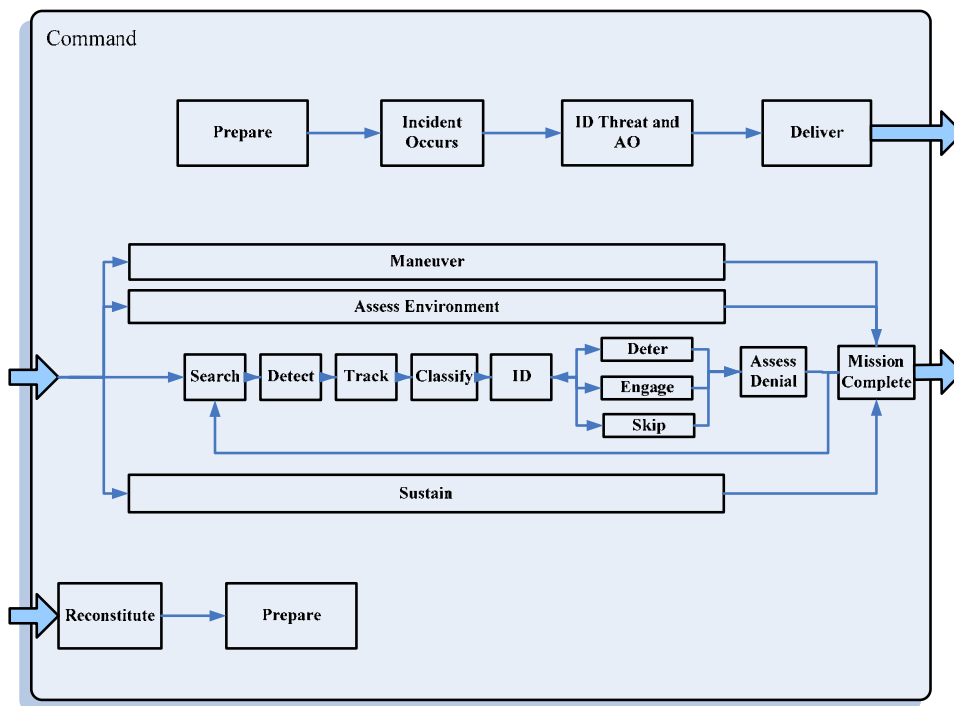


Figure 22: Functional Flow Diagram

### 2.1.8.6 Operating Concept

This Operating Concept describes SEA-8’s view of Littoral ASW in the 2025 time frame. Emphasis is placed on the full integration of deployed ASW platforms into a total ASW combat system with the ability to produce a “thinking field” of fully networked combat, communication, sensor, and weapons systems designed to strip the

oceans away from our adversaries. SEA-8 envisioned these thinking fields of systems to be composed of a SoS comprised of air, surface, and subsurface platforms, both manned and unmanned, with the ability to rapidly surge from home bases, if not already on station as part of a forward-deployed strike group. The SoS will serve to deny the threat posed by enemy submarines within the world's oceans, including the littoral waters. Specific to SEA-8's analysis is the threat posed by next-generation AIP diesel submarines within the littorals, believed to be a major threat for the 2025 time frame.

The ASW Search and Engagement mission is comprised of five phases: Operational Planning, Search Planning, Search Execution, Search Evaluation, and Contact Evaluation. The intent of this concept of operations is to accurately represent future ASW operations and standardize analysis efforts.

Operations in the 2025 time frame will be centered on dominating the littorals by rapidly achieving area control despite difficult sound propagation profiles and dense surface traffic.<sup>46</sup> The operating environment will be complex. The enemy will be operating with significant advances in both stealth technology and weapon lethality. Therefore, it is essential that a system be developed that can avoid detection and be resistant to attack, as well as to penetrate and function in denied areas for sustained independent operations.<sup>47</sup> SEA-8 considered various SoS alternatives that can achieve these broad objectives.

2.1.7.6.1 OPERATIONAL PLANNING. The Operational Planning phase describes the strategic- and tactical-level planning required for any ASW operation and is often the most complex and demanding area of focus prior to an operation. Environmental conditions, enemy force capabilities and limitations, own-force capabilities and limitations, and mission objectives must be defined and understood prior to the commencement of the ASW operation. The environmental conditions inherent in the operational space focus on the physical characteristics of the AOR, where specific ASW operations are to take place and are critical to any ASW operation, including the oceanographic and meteorological conditions present. An in-depth knowledge of enemy

---

<sup>46</sup> United States Navy, "Anti-Submarine Warfare, Concept of Operations for the 21<sup>st</sup> Century," Navy Public Affairs Library, 3 February 2005.

<sup>47</sup> Department of the Navy, "The Navy Unmanned Undersea Vehicle (UUV) Master Plan," 9 November 2004, p. 3.

force capabilities is required to formulate a strategy to maximize detection and kill probabilities. This calls for the synergy of organic data collection with national-level intelligence products, and the ability to rapidly act on information as it becomes available. For this reason, commanders must also have an in-depth knowledge of their own force's capabilities within their fleet.

As capabilities progress in network centric warfare, UUVs, and standoff precision weapons progress, the networking of self-aware, autonomous sensor fields coupled with manned and unmanned platforms, will transform ASW.

The platforms of the SoS architecture must be capable of performing both overt and clandestine operations in areas inaccessible to conventional naval and maritime forces. These platforms must be capable of performing a deterrence mission that will be used to prohibit enemy assets from leaving port, from approaching friendly HVUs within a given range, or from conducting operations within a given area of concern. Additionally, the platforms must have the ability to initiate offensive actions. These actions may be either hard kill, soft kill, or simply used to disrupt the environment to such an extent that continued operation by the enemy becomes impossible. Most importantly, the SoS should be capable of accomplishing missions in any littoral region of the world without the assistance or support of local nation-states. The importance of self-reliance and autonomy cannot be underestimated.

2.1.7.6.2 SEARCH PLANNING. The Search Planning Phase describes the ASWC's iterative plan for reducing the Area of Uncertainty (AOU) around an enemy submarine based on the capabilities and limitations of the friendly force, the environmental conditions and the available information on the potential enemy submarine. Detection ranges and search characteristics for each sensor should be evaluated, including applications of active and passive sonar, radar, electronic surveillance sensors, and through visual means by force personnel. The ASWC will develop a search plan, task individual units, evaluate progress and establish confidence probabilities based on the progress of the search.

2.1.7.6.3 SEARCH EXECUTION. The Search Execution Phase describes the implementation of the ASWC's Search Plan and begins with the systematic search of areas most likely to contain an enemy submarine. Proper C2 of

assigned units is critical in achieving unity of effort by maximizing the area covered in the least time, with the least amount of over-search. As the ASWC evaluates the progress of the execution efforts, changes to the search plan may be necessary. The speed and confidence with which possible submarine contacts are evaluated will determine overall success.

2.1.7.6.4 SEARCH EVALUATION. The Search Evaluation Phase describes the ASWC's classification of contacts detected by platforms and sensors operating in the group. Corroboration by multiple sensors and continuous monitoring of own force progress and the environment is often the best way to aid in classification. The ASWC will evaluate and update the search plan anytime the threat, environment, or friendly force changes.

2.1.7.6.5 CONTACT EVALUATION. The Contact Evaluation Phase is characterized by a more precise evaluation of a contact gained in the Search Evaluation phase. Contacts can be evaluated by the ASWC as one of three categories: 1) Non-Sub (the contact is not a submarine); 2) Prob-Sub (the contact is a probably a submarine); or 3) Cert-Sub (the contact is a submarine). These concepts are described in more detail in Appendix F. The intent remains to reduce the AOU surrounding a contact to a known size for engagement or avoidance. Based on the evaluation of the ASWC, a Cert-Sub contact will usually be tracked or engaged.

Additionally, tracking a submarine can be categorized in two distinct ways, the first of which requires that a fire control solution must be maintained, referred to as a Close Track. A Loose Track is used if a submarine must be monitored periodically and contact is allowed to be intermittent. If an engagement is ordered based on the evaluation, it is imperative that the contact be evaluated to be in a location where friendly forces can engage the submarine without jeopardizing the safety of other friendly forces.

## **2.1.9 FUTURES ANALYSIS**

### **2.1.9.1 Past, Present, and Future ASW Strategy**

The path for tomorrow must always begin with the search and understanding of yesterday. With this in mind, SEA-8 researched not only current ASW

systems, but also past systems and the triggers for their evolution. Germany unknowingly became the trigger for ASW with the incorporation of submarines into their maritime strategy against the Allies in World War One. Unrestricted warfare in World War Two brought the US into the ranks of countries that utilized the unique capabilities of submarines.

Futures Analysis is a critical last step in needs analysis of the SEDP. Futures analysis is important because even a small under estimation could possibly leave the US with a second-tier capability in the crucial warfare area of littoral ASW. ASW is one of the critical core competencies the US Navy must continue to master in order to achieve maritime dominance in the littorals. In order for Futures Analysis to be successful, the previous pieces of the Needs Analysis puzzle must have been properly performed. Needs Analysis provided SEA-8 with a thorough decomposition of the current system and a transparent view of the stakeholders' vision for system development. SEA-8 utilized this view to develop alternatives that may be used in the future as threats and missions evolve.

At the current rate of technological advances, future ASW threats will be as vast as the ocean within which they will operate. The threat could easily mature to a point where technological advances in other areas may remove the clandestine nature of ASW.

Forecasting into the future is no small task, particularly when looking into a topic as sensitive as ASW. However, the previous topic of functional decomposition can provide insight to ASW's current status, particularly key ingredients such as technology, economics, politics, geography, and ultimately, a player's ability to effectively combine these ingredients in the water space. The complexity and uncertainty of future ASW involvement is addressed by Jan Breemer below:

The choice of ASW strategy is determined by two factors: (1) the prevailing balance between submarine and anti-submarine technologies, and (2) the particular warfighting purposes of the submarine that need defeating. The foreseeable technological balance will hinge on (a) the submarine's "stealth" versus ASW detection capabilities, and (b) the ability of the ASW defender to attack the submarine quickly and accurately at "standoff" ranges. As long as the oceans do not become "translucent," prospects are that the submarine will continue to evolve and assume tasks that have traditionally been the prerogative of surface



fleets... New submarine roles will prompt a new “menu” of ASW strategies.<sup>48</sup>

These “menus” of ASW strategies have prompted the US to broaden its focus on ASW:

In addition, since the end of the Cold War, the Navy has also recast its strategic focus to the littorals, a complex environment that includes both deep waters and the most adverse of shallow waters. Broader threat technologies, variable oceanographic conditions, the larger number of nation-state “players,” and the extended time since the Navy has fought a significant underwater campaign all contribute to growing uncertainty about the balance of capability between US and friendly ASW forces and the submarine forces of potential enemies.<sup>49</sup>

From this historical perspective, the US ASW problem could easily prove unwieldy into the future. As such, plans for the US to shift toward effects-based operations for the future is highlighted below:

In the past, ASW was conducted by a force-on-force concept of operations with the attrition of the enemy forces over time by means of far-forward deployments and layered defenses. While this approach was effective in certain regimes, emerging technologies and operational concepts now allow us to minimize own-force risk and unnecessary force-on-force engagements. Accordingly we are moving increasingly to effects-based operations wherein our platforms employ more capable distributed sensors and high gain arrays to achieve domain awareness and stand off devices to eliminate or neutralize subsurface threats in ways that minimize risk to our own and friendly forces. This concept holds enemy submarines at risk, creating a maritime shield within and around the sea base, providing protected passage of combat and logistic units and maritime commerce along sea lines of communication, and creating a networked, distributed ASW combat force scaleable across all levels of engagement.<sup>50</sup>

Since the late 1980’s new challenges have emerged as a result of the growing presence of modern submarines and mini subs in navies of third world and non-aligned nations. Moreover, the significant improvement in the stealth of nuclear and non-nuclear submarines, as well as the extended submerged endurance of the latter, and advanced combat

---

<sup>48</sup> Jan S. Breemer, *Anti-Submarine Warfare: A Strategy Primer*, Naval Postgraduate School, Monterey, CA, July 1988, p. 12.

<sup>49</sup> The “capabilities of nuclear submarines dominated major power concerns during the Cold War,” Program Executive Office Integrated Warfare Strategies 5 (PEO IWS 5), *21<sup>st</sup> Century ASW MASTER PLAN*, 21 December 2004 (the overall classification of this document is SECRET; however, the portions that appear in this paper are unclassified), p. 7.

<sup>50</sup> *Ibid.*

systems and weapons all combine to make it imperative that the Navy refocus its efforts on the means for detecting, identifying, and prosecuting our adversaries' submarines in crisis and conflict.<sup>51</sup>

The role of ASW in the future is pivotal to the goals outlined in the US 2004 NMS. Within that document, the goals for the future operating environments, to include the littorals are outlined.

The United States will conduct operations in widely diverse locations—from densely populated urban areas located in littoral regions to remote, inhospitable and austere locations. Military operations in this complex environment may be dramatically different than the high intensity combat missions for which US forces routinely train. While the US Armed Forces' will continue to emphasize precision, speed, lethality and distributed operations, commanders must expect and plan for the possibility that their operations will produce unintended second- and third-order effects. For example, US forces can precisely locate, track, and destroy discrete targets to reduce collateral damage and conclude operations as quickly as possible.<sup>52</sup>

Incorporating the US NMS is the US Naval Strategy of Sea Power 21. Sea Power 21, a document that explains the vision and direction of the US Navy in the 21<sup>st</sup> Century, explains that the future defense consists of

...layered global defensive power based on control of the seas, forward presence, and networked intelligence. [Sea Shield] will use these strengths to enhance homeland defense, assure access to contested littorals, and project defensive power deep inland... The foundation of these integrated operations will be information superiority, total force networking, and an agile and flexible sea-based force.<sup>53</sup>

Just as the ASW environment (threats and warfighting assets) has changed dramatically since World War Two, it will change even more by 2025. More stealth, less dependence on fuel as a sole source of propulsion, and more clandestine operations all threaten the safety and security of peaceful and sovereign nations.

Cote, in The Third Battle, and a noted expert in ASW, recognizes the strides that submarines alone have made in the last few decades to reach the level of technology and adeptness they possess today.

---

<sup>51</sup> *ASW Master Plan*, p. 2.

<sup>52</sup> *United States National Military Strategy 2004*, p. 5.

<sup>53</sup> Vern Clark, ADM, USN, *Sea Power 21: Projecting Decisive Joint Capabilities*, Navy Office of Information, Washington, DC, September 2002, [published in Proceedings, October 2002].

Submarines are better... in the form of non-nuclear with [AIP] systems... they greatly reduce the indiscretion rate of a traditional diesel-electric submarine, which must expose a snorkeling mast to recharge its batteries every few days.<sup>54</sup>

It is also true and carries with it significant merit that

...modern submarines are also armed with better weapons and fire control systems... the air independent non-nuclear submarine with the submarine launched anti-ship missile... These platforms can launch fire-and-forget missiles from over-the-radar horizon without the need for the noisy and battery-draining approach run necessary for a traditional torpedo-armed diesel electric boat.<sup>55</sup>

All of these statements of how the submarine has advanced and what new ASW threats exist today and will exist in the future can be summarized in the following three bullets that represent the threats of a future ASW environment:<sup>56</sup>

- The capabilities and relatively wide availability of modern non-nuclear submarines
- The United States' extreme aversion to casualties in post Cold War conflicts over less than vital interests, and
- The US Navy's doctrinal focus on power projection from the sea at the expense of sea control

Three things are very clear to those who study ASW. First, ASW is about “surveillance”—knowing where the enemy’s submarines are at all times and having a thorough understanding of the battlespace environment. Second, change will be required if the threat is to be subdued in time to prevent mass casualties and future wars.<sup>57</sup> And third, integration is a must. Today, the SAG integrates all of the platform’s sensors into the combat systems onboard surface and subsurface vessels. Integration must continue into the future, adding to the overall picture for mission planning and execution “submarines, MPA, and surveillance assets” through the use of “C4I and situational

---

<sup>54</sup> Owen R. Cote, Jr., The Third Battle, Naval War College, Newport, RI, p. 80.

<sup>55</sup> Ibid.

<sup>56</sup> Ibid., p. 79.

<sup>57</sup> Ibid., p. 90.

awareness tools, communication systems, sensor contact/fusion, and communications at speed and depth.”<sup>58</sup>

### ***2.1.9.2 Futures Analysis From a C4ISR Perspective***

**Processing Technology:** The importance of computer-based technology in people’s everyday lives will continue to motivate the business world to push toward ever increasing computer processing capabilities based on customer demand. While in recent years, the business world has outpaced the research and development efforts of the military, military agencies will continue to benefit from commercial endeavors. It is highly likely that this trend will increase at an even greater rate in the near future as technology and the manufacturing of high-technology components continues to spread to the Third World. As China and India continue to train and educate their populations as both users and producers of technology, these tremendously expanded markets should lead to an increase in the discovery of improved methodologies.

The exploration of neural-technology, using living tissue in computer circuits, has the potential to increase computing power by an order of magnitude, and while many experts argue over the practical timeline for technological introduction, it is possible that a major breakthrough will occur during the next 20 years that will create unimaginable possibilities for our C4ISR system.

Nanotechnology will also continue to improve processing power and will likely become commonplace in military technology well before 2025. As circuitry continues to get smaller, more processing can be accomplished per pound of hardware. This trend will have a positive impact on the deployability of future sensors. It is, therefore, assumed that Moore’s Law will continue to hold true for the majority of the next 20 years with regard to computer processing.

**Processing Implications:** Due to these vast possibilities for improvement in processing capability over the next 20 years, SEA-8 recognizes a need in processing practices when applied to ASW. Today most of the sensors used in ASW systems collect raw data from the environment and feed it back to a single central processor on a ship or aircraft for analysis. This is primarily due to the need for relatively large computers to

---

<sup>58</sup> Richard L. Coupland, *Theater ASW Experiment 2004 Lessons Learned*, NAVSEA, Draft 19 July 2005, p. 11.

process the volumes of information needed to convey an understanding of the environment to system users. The downside to this practice is found when considering the large amounts of bandwidth required to be used in transferring the requisite amounts of “raw data” when many sensors are used in a single sensor field. When the bandwidth required for conveying this information exceeds the bandwidth available, an information backlog is created, leading to data latency—a potentially catastrophic characteristic in real-time network-centric warfare.

To alleviate the bandwidth demand placed on a wireless system, smart sensors should perform their own analysis processing, transmitting only the results of their analysis and not their entire library of collected raw data. This “front-end” processing shift saves bandwidth and has the potential to greatly reduce the prosecution timeline of a wireless ASW system.

**Worldwide Communications:** As the world grows increasingly smaller with the expansion of wireless communications, the world’s population will increasingly place demands on the finite electromagnetic spectrum. The management of this spectrum will take on an evermore important role as spectrum resources become strained, and while agencies like the Federal Communications Commission (FCC) regulate frequency allocation within the US, they have little or no authority overseas. The importance of international regulatory agencies will continue to grow in importance and will require authority to enforce international standards. It is foreseeable that many countries will lack the infrastructure to enforce these rules, and the appearance of ad hoc or pirated portions of the spectrum will become more common.

**Communications Implications:** As the world’s human population places increasing demands on the electromagnetic spectrum, the mismanagement of this resource will add noise and degrade communications performance for US military operations when competing for common portions of the spectrum. It would be a false assumption that the military can simply “burn through” the general communications traffic, or take action to remove the civil traffic from the spectrum. While this solution is referred to frequently by military planners over the course of our research, any decision to do so would likely be made at levels above the DOD and include widespread political ramifications. Therefore, the Communications Team did not use this assumption and

planned to find work-arounds that accommodate both military and civilian traffic on the electromagnetic spectrum.

**Satellite Communications:** As demand on terrestrial communications systems continues to grow, much of the traffic on these systems will be shifted to communications satellites. There are only a finite number of geostationary satellite “slots” in orbit, and once filled, it is possible that communications channels over these relay platforms may become saturated or increasingly expensive. Many predict that it is only a matter of time before these satellites reach the limits of their capabilities.

Low Earth Orbit (LEO) communications satellite systems, like Iridium, have several benefits over geostationary satellites. They also impose several downsides. As a matter of physics, geostationary satellites are all located on the equator making communication at high latitudes more difficult due to the poor look angle (the higher the latitude the lower the satellite will appear on the horizon), and in extreme cases impossible (near the Arctic or Antarctic circle). LEO satellites, on the other hand, are in polar orbit and as a result perform much better in high latitudes. However, their position is not static and communications systems using LEO satellites generally need more robust tracking devices and accurate position scheduling to locate and track these satellites. The main benefit of LEO systems are the relatively unlimited number of satellites that can be placed in orbit and the fact that shorter distances require less power to exchange information.

Regardless of satellite type, it is often assumed that since most communications satellites are owned by the US, or by companies based in the US, that the federal government will have the right to “reallocate” these resources in support of military operations in wartime or national emergency. The decision to do so has widespread political ramifications and is outside the authority of the US military to dictate. While this may be a valid assumption in extremis, a war for national survival, the application of this assumption for low-intensity, high-frequency military operations is unfounded. Therefore, SEA-8 recognizes the need for the Navy to invest in alternative methods for communications relay when commercial or military satellite channels are degraded or unavailable.

One potential possibility is the recent development in inexpensive, expendable, short range satellites, persistent high altitude unmanned aerial vehicles (UAV), and lighter than air (LTA) platforms. These options are explored in greater detail in the section covering alternatives generation.

**The Littoral Environment:** The deployment of a “thinking fields” of platforms, sensors, and weapons anywhere in the world is critical to the realization of the Navy’s goals for ASW. Understanding the physical environment of 2025 is important for the development of a system designed to deploy this thinking field in the littorals. The US Maritime Administration predicts that worldwide shipping on the high seas will double by the year 2025.<sup>59</sup> This means that the number of “white,” or neutral, contacts that must be sorted through and analyzed will be more than double what it is today.

As the world’s human population continues to expand, the demand for food will greatly increase the number of fishing boats within our potential operating area. While this also increases the contact processing portion of our system, trawling operations will no doubt degrade system performance by removing many of our deployed sensors. Clandestine operations will also become more difficult as the number of detection opportunities increases proportionally with the number of people at sea.

**Environmental Implications:** While technology will continue to make computing processes easier and quicker for C4ISR systems, the number of environmental inputs into our littoral system will also continue to grow. The forecast calls for an even more complex environment than the one available today.<sup>60</sup>

As technology increases, it is important to realize that technology has physical boundaries that are not likely to be conquered, barring a major leap in human understanding. For example, most artist renditions of the US Navy’s ASW Master Plan include various pictures of undersea sensors, weapons, and platforms communicating over great ranges via wireless networks. It is easy for the uninformed to assume that since today’s surface and airborne forces communicate over virtually unlimited range at extremely high data rates that a similar relationship can be found in the undersea

---

<sup>59</sup> [http://www.bts.gov/publications/the\\_changing\\_face\\_of\\_transportation/chapter\\_01.html](http://www.bts.gov/publications/the_changing_face_of_transportation/chapter_01.html), accessed 18 November 2005.

<sup>60</sup> Ibid.

environment. This assumes that data can be passed through water as easily as it is passed through air or a vacuum—nothing could be farther from the truth.

The physical boundaries of a system may be improved on by technology, but many will not be shattered in the next 20 years. It has been the focus of SEA-8 to explore the possibilities of science with respect to these boundaries, with a firm grounding in reality, to avoid venturing into the realm of science fiction.

### ***2.1.9.3 False Assumptions for the Future***

While not critical to the following futures analysis, one recurring issue deserves brief discussion as it occurred so frequently during the course of research on this project. The Command Team's basic research found that the most common error in attempting to predict future performance of high-tech systems is found in the misapplication of Moore's Law.

Moore's Law refers to an observation made by Gordon Moore in 1965 that states that the number of transistors per square inch contained on an integrated circuit card has doubled every 18 months since the integrated circuit card was invented. This implies that the processing power of each integrated circuit card doubles every 18 months, and while this observation has held true, in general, its application is only valid when discussing processing power.

Many people, from all disciplines encountered, frequently and falsely apply this law when discussing technology in general. This misapplication results in overly optimistic predictions in all areas of technology. For example, a recurring assumption discovered when discussing undersea networks follows the analogy that since nodes in an undersea network can communicate at ranges of up to 2,000 yards today, they will probably be able to communicate at 26,000 yards in 2025.<sup>61</sup> The Command Team research does not support this conclusion. Nonetheless, many subject matter experts use this analogy to assume future performance.

---

<sup>61</sup> 2025 – 2005 = 20 year, 20 years/18 months = 13.3 Moore's Law Periods; thus, 13.3 \* 2,000 yards = 26,666 yards or ~13 NM.



#### ***2.1.9.4 Future Potential Threats***

As the US Navy evolves to continue maritime dominance in the world's littoral regions, new ASW threats are perpetually emerging that have the potential to offset those efforts. Technology diffusion and dual-use technologies in the world market have blurred the lines between commercial and military technology. This blurring of the lines has allowed adversaries the opportunity to increase their capabilities at minimal cost to economic and political capital. This forms a nexus for potential adversaries to possess lethal platforms and weapons that could be used to offset comparative US ASW advantages. The primary known threats being projected into the future are AIP, diesel, and nuclear submarines, and UUVs.

Specific problems in the present suggest that future ASW operations in the littorals will remain complex. Rudko, in "Logistical Analysis of the Littoral Combat Ship" thesis, made the following statement, which gives relevance to the problem of determining short-falls in ASW:

...the Navy must develop the capability to maintain an Aircraft Carrier Operating Area clear of submarine-delivered and floating mines, improve the capability to destroy or evade large numbers of submarines operating in the littorals and develop the capability to destroy large numbers of small anti-ship cruise missile-armed combatants or armed merchant vessels in the littoral areas, without relying on carrier based air. Currently, sensors and weapons in the littoral environment have limited ranges due to environmental conditions and the clutter of maritime traffic. In addition, the proliferation of high-tech weapons and sensors potentially provides the enemy with the tools necessary to exploit the vulnerabilities of our current Naval force when operating inside the littorals. As a result, the Navy's current ability to counter enemy submarines, small craft and mines in the littoral environment is limited.<sup>62</sup>

Likewise, the ASW Master Plan focuses on the threat of tomorrow:

Today's emerging submarine threat is characterized both by (1) the emergence of modern submarines in the inventories of potential adversaries, and (2) by rapid dissemination of technologies that improve their warfighting capabilities. Several countries now build quality submarines, and the nature of the military arms market makes them increasingly available. Very quiet submarines with air-independent

---

<sup>62</sup> David D. Rudko, *Logistical Analysis of the Littoral Combat Ship*, Naval Postgraduate School, Monterey, CA, March 2003, p. xv.

propulsion that can provide several weeks of quiet, submerged endurance are already on the market. Pump-jet propulsors, acoustic hull coatings, active cancellation of machinery vibration, and magnetic bearings are increasing the acoustic stealth of these newer conventional submarines. The incorporation of commercial-off-the-shelf (COTS) components is improving submarine sensors and signal processors by an order of magnitude, and new weapons are making Third-World submarines even more potent threats. ...The bottom line then becomes the fact that a “navy defending its own littoral with a modern, 21st Century submarine could be both a serious tangible and intangible threat to US and allied sea based forces.”<sup>63</sup>

### ***2.1.9.5 Closing the Future Capabilities Gap***

Ingenuity and advanced technology are without a doubt key ‘asymmetric’ strengths of the US Navy. Focused research and deployment, linked to a transition strategy that will speed the acquisition of systems and platforms and their introduction into the Fleet, will continue to be strongly supported. In support of the emerging CONOPS [Concept of Operations] new Task Force ASW, system concepts are being explored and the Office of Naval Research (ONR) has established a Littoral ASW Future Naval Capabilities (FNC) program focused on ship self-defense, distributed search, tactical surveillance, precision localization, and rapid attack. In addition, ONR’s Discovery & Invention strategy focuses on maintaining a national infrastructure for developing fundamental ASW-unique science and technology, demonstrating feasibility of critical system components that address key elements of the overall ASW Strategy, and developing technology products for future FNC and acquisition programs. Likewise, the Defense Advance Research Projects Agency (DARPA) has also undertaken several projects in support of the Navy’s ASW capabilities; its Low-Cost Anti-Submarine Sensors and Weapons project is of particular interest. These new technologies will be aggressively exploited both to accelerate future improvements to today’s systems and to enable early introduction of new and innovative system concepts.<sup>64</sup>

Fundamental to holding enemy forces at risk will be the dynamic application of Sea Strike and Sea Shield capabilities for persistent intelligence, surveillance, and reconnaissance; time-sensitive strike; information operations; and covert strike. Simultaneously, battlespace superiority will be created as linked sensors, platforms, and kill vehicles

---

<sup>63</sup> Ibid., p. 8.

<sup>64</sup> Ibid., p. 2.

consolidate area control, allowing joint forces to ‘climb into the ring’ and stay there.<sup>65</sup>

Advanced technologies employed in support of friendly forces will include exploiting the rapidly increasing computing power of sensors and networks. When coupled to the operational persistence afforded by Sea Basing, such systems will provide pervasive awareness by way of hundreds, even thousands, of small sensing and computing devices that permeate the operating environment, yielding unprecedented situational awareness and highly detailed pictures of the battlespace.<sup>66</sup>

According to the ASW Master Plan, the Task Force ASW (TFASW) was created to develop various strategies in order to successfully counter future 21st Century ASW threats through changes in “doctrine, organization, training, materiel, logistics, personnel, and facilities.”<sup>67</sup> These strategies are characterized as “Near-Term” and “Long-Term” and are detailed in Table 1:

<b>Near-Term ASW Transformation</b>	<b>Long-Term ASW Transformation</b>
Enhanced signal processing	Distributed netted sensors
Bistatic towed array	Rapid attack weapons
Low Frequency Array	Advanced data relays
Advanced Deployable System	Integrated weapon systems
Advanced sonobuoys	
Periscope detection systems	
Common maritime picture	
Open architecture torpedoes	
Torpedo countermeasures	

**Table 1: ASW Sea Power 21: Near- and Long-Term**

The goal of the near-term strategy is to reduce the detect-to-engage sequence by “employing networked data, collaborative planning, and rapid engagement to quickly destroy enemy forces.” The long-term strategy “will exploit these tactical advances to achieve two key operational level objectives listed” below:

- Hold enemy forces at risk: (To) deny enemy submarines an offensive capability by maintaining the ability to destroy them, if and when required, at a time and place of our choosing
- Secure Friendly Maneuver Area: (To) drive away or destroy enemy submarines, thereby protecting maritime operating areas. (To) protect US

<sup>65</sup> Ibid., p. 14.

<sup>66</sup> Ibid.

<sup>67</sup> *ASW Master Plan*, p. 13.

and coalition naval combatants, support ships, and merchant shipping from undersea attack within and en route to vital operating areas<sup>68</sup>

Areas that need a leap forward which would improve overall ASW capability are listed below:

- Rapidly-deployable, active-passive distributed fields to cover the full range of shallow and deep environments
- Deep-water, bottom-moored, and shallow-water/bottom-mounted sensors
- Long-endurance, low altitude-capable, tactical UAVs for small-area search and prosecution
- Compact, rapid attack weapons
- Decoys and countermeasures
- Autonomous ASW sensor systems with a large number of elements
- Large-area, nonacoustic search capability against shallow submarines
- Long-range, standoff ASW weapons
- Submarine locating devices<sup>69</sup>

Recent fleet exercises and extensive analysis [have] shown that significant ASW challenges are emerging. In response to this the Navy has launched a broad, comprehensive, and vigorous program to ensure continued ASW dominance. While much remains to be done, and in many respects the way ahead for the 21st Century ASW remains a ‘work in progress,’ the following is clear:

- ASW will be conducted as an effects-based, networked, system-of-systems enterprise, complementary to, and in support of, Joint Forcible Entry Operations (JFEO)
- Navy’s ASW operations will take full advantage of joint-service war fighting capabilities and national informational assets
- Future ASW operations will include assets, including high gain arrays, distributed off-board sensors, advanced off-board vehicles, nonacoustic measures, and precision stand off weapons

---

<sup>68</sup> Ibid.

<sup>69</sup> Ibid., p. 23.

- A focus on ASW and faster delivery of capability to the Fleet will be accomplished through close interaction between assigned Fleet, OPNAV, NAVSEA, and PEO offices
- ASW systems-acquisition decisions will be supported by comprehensive system-of-systems analysis based on accredited models and simulations
- ASW systems-developments decisions will be based on early at-sea testing and concurrent tactics development
- Navy will continue to engage industry and to foster ASW innovation
- ASW systems design will continue to incorporate the principles of open architecture, commonality and optimized manning<sup>70</sup>

In the 21st Century ASW world, the technology could be predominantly unmanned and have the ability to be deployed around the world in a minimum of time. Interconnected sensors will have the ability to search, detect, and track the enemy until ordered to prosecute. When this occurs, the enemy will have no sanctuary in any corner of the world, regardless of how remote the corner is.

## **2.2 REQUIREMENTS GENERATION**

Through extensive research and consultation with our stakeholder population, SEA-8 has arrived at a set of Littoral ASW requirements for the SoS. The details of those requirements have been broken down into four functional areas: Deploy, Prosecute, Defeat, and Command. The following sections present the respective functional areas.

SEA-8 intends to design a SoS that possesses a deployment schedule to (1) support the National Defense Strategy's 10-30-30 response metric; (2) prosecute the four identified 2025 ASW threats (diesel, AIP, or nuclear submarine, or UUV); (3) reduce enemy threat platform performance; and (4) transmit and receive communications, data, and ISR information across a secure and survivable distributed control network.

---

<sup>70</sup> *ASW Master Plan*, pp. 2-3.

## 2.2.1 Requirements for Deployment

In order to address stakeholder needs, the Deployment Team determined that the SoS must possess a deployment and logistical system that supports the CNO's 10-30-30 response metric for littoral ASW in 2025. Figure 23 illustrates the overall Deploy functional structure and the breakdown into lower-level supporting functions.

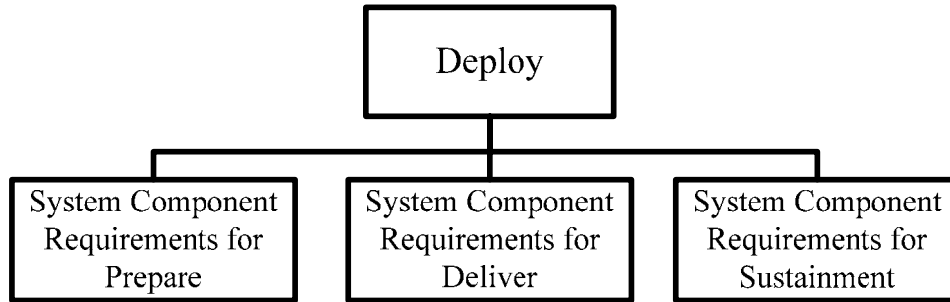


Figure 23: Breakdown of Deployment Team's Overall Functional Structure

### 2.2.1.1 System Component Requirements for Prepare

From Figure 23, the first lower-level function that supports a deploy function was determined to be “system component requirements for prepare.” It is necessary that the SoS components must remain in a constant state of readiness. A constant state of readiness will support rapid operational employment. To that end, the SoS architecture must (be):

- Easy to train to (either deployed at sea or stationed ashore)
- Easy to maintain
- Able to withstand deployment at sea or storage for long periods ashore
- Modular
- Interoperable with legacy systems and future programs of record
- Self-storing when not in use

### 2.2.1.2 System Component Requirements for Deliver

The National Defense Strategy's success is based on the “10-30-30” metric. The “10-30-30” measurement defines the goal for closing forces to be within 10 days and defeating an adversary within 30 days. To that end, SEA-8 has determined that the Operating Area (OA) of 10 NM x 10 NM must be under surveillance within 72 hours and the AOR (100 NM x 200 NM area) within 10 days. In order to satisfy these

metrics and fulfill the subfunction of “deliver system components,” the SoS components and architecture must:

- Be viable to transport
- Interoperate with the Sea Base
- Be self-initiating and ready for operations on deployment
- Be able to deliver the sensor assets required to provide a 0.5 Pd against the four identified future threats, across a contested waterway (not to exceed 100 square miles), within 72 hours
- Be able to deliver the sensor assets required to provide a 0.8 Pd against the four identified future threats, across a contested AOR (not to exceed 20,000 square miles) within 10 days

### ***2.2.1.3 System Component Requirements for Sustainment***

In order to fulfill the Deploy subfunction of “sustain system components,” the SoS components and architecture must be able to:

- Provide the logistical support necessary to sustain the deployed assets within the AOR for 30 days

Those platforms, used during deployment and logistic sustainment, must be able to:

- Supply and/or deploy and organically support SoS components (self-deploying platforms)
- Deploy a full spectrum of SoS components to include UUVs and distributed network sensors and components (deployment platforms)

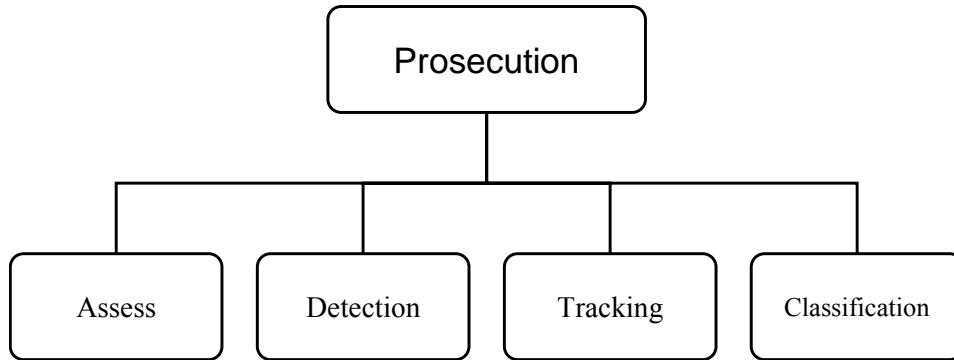
### **2.2.2 Requirements for Prosecution**

After completing the stakeholder analysis, the Prosecution Team determined that advanced technologies employed by a future littoral ASW SoS must “provide pervasive awareness” and “permeate the operating environment, yielding unprecedented situational awareness and highly detailed pictures of the battlespace.”<sup>71</sup>

---

<sup>71</sup> Program Executive Office Integrated Warfare Strategies 5 (PEO IWS 5), *21st Century ASW MASTER PLAN*, 21 December 2004, p. 14.

Figure 24 illustrates the overall Prosecution functional structure that includes the four identified supporting subfunctions.



**Figure 24: Function and Subfunctions for Sensors**

### ***2.2.2.1 Assess***

The Assess function for the SEA-8 tasking includes an environmental assessment that comprises a need for oceanographic and atmospheric data in the area of responsibility (AOR). Having this knowledge will allow the decision maker to determine the quantity and type of sensors required as well as their probability of success in detection and tracking COIs.

**Environmental Assessment:** Successful ASW in the littorals depends on a SoS with the ability to exploit and/or adapt plans based on the oceanographic and atmospheric environmental conditions.

The assessment for water and bathymetric conditions should include vertical and horizontal variability in a variety of physical parameters. Sound velocity profiles (SVPs), sea surface temperatures, ocean fronts and eddies, bathymetric and topographic conditions, anomalies, ambient noise, and ocean currents, over time of year should be included in an environmental assessment.

The assessment for atmospheric environment conditions should provide a variety of atmospheric information. Analyzed and forecasted air temperatures, wind speeds and directions, sea and swell height and direction, and period, sky conditions, precipitation, icing for ASW aircraft operation, and the location, movement, and intensity of frontal activity should be included in an atmospheric environmental assessment.<sup>72</sup>

---

<sup>72</sup> Antisubmarine Warfare Commander's (ASWC) Manual (NTTP 3-21.1) pp. 3-1 – 3-2.



For both the oceanographic and atmospheric environments, the SoS must be capable of providing on-demand and periodic environmental assessments.

### **2.2.2.2 Detection**

The Littoral ASW SoS must be capable of conducting clandestine search operations that consist of systematic detections within a particular area, barrier, or datum to establish, within a high degree of certainty, the presence and/or absence of submarines.<sup>73</sup> According to *Anti-Submarine Warfare*, “detection can happen in many ways and submarines by their nature, construction and modes of operation offer different opportunities to different systems.”<sup>74</sup> In a similar fashion, once detected, the SoS will be required to localize. Vice Admiral John Morgan (CNO N3) stated:

The near-shore regional/littoral operating environment poses a very challenging ASW problem. We will need enhanced capabilities to root modern diesel, air-independent, and nuclear submarines out of the ‘mud’ of noisy, contact-dense environments typical of the littoral, and be ready as well to detect, localize, and engage submarines in deep water and Arctic environments.<sup>75</sup>

Additionally, Admiral Natter, previous Commander, Fleet Forces Command, goes further to express the need to “develop an undersea network and nonacoustic detection methods to enable a sensor-rich anti-submarine warfare environment and advanced weapon technology to counter littoral threats.”<sup>76</sup>

This SoS must utilize innovative technologies both of the acoustic and nonacoustic nature. After identifying and refining stakeholder requirements, the Prosecution Department has determined that to detect and localize underwater enemy threats this SoS must use available sensors to perceive a contact and determine if the contact is of interest. The SoS is required to arrive at an accurate position for a submarine contact, using available sensors.

---

<sup>73</sup> Ibid., p. 4-1.

<sup>74</sup> W. J. R. Gardner, *Anti-Submarine Warfare*, Brassey’s, London, 1996, p. 60.

<sup>75</sup> <http://www.chinfo.navy.mil/navpalib/cno/n87/usw/autumn98/anti.htm>, accessed 22 July 2005.

<sup>76</sup> <http://www.usni.org/proceedings/articles03/pronatter11-2.htm>, accessed 22 July 2005.

### **2.2.2.3 Tracking**

Shifting from the requirements of detection and localization, the follow-on requirements of tracking and targeting are the next steps in the littoral operating environment. To define what the tracking and targeting requirements are, it may prove useful to remove any misconceptions. In this regard, it is important to note that tracking is not required to be defined as trailing. From *Anti-Submarine Warfare and Superpower Strategic Stability*:

Far fewer sensors and platform combinations have been judged suitable for trailing because this task is, for the most part, restricted to instruments carried both on surface ships and submarines of which there are both acoustic and nonacoustic candidates. Tracking becomes less demanding than trailing, it is potentially open to air- and water-borne acoustic and nonacoustic systems.<sup>77</sup>

For the purposes of our SoS, the requirement for tracking and targeting will be:

- The COI's bearing, range, course, and speed are known with sufficient accuracy to record and indicate its history of movement
- The SoS will be able to generate an estimate of past and future movement to enable a fire control solution (FCS)

### **2.2.2.4 Classification**

Overall requirements of Navy future systems promote implementing automation in processing and operations. Every classification and identification step in today's ASW environment has an operator in the loop. Being able to classify and identify a contact automatically reduces manning requirements and, depending on the stability of the technological tools, also improves accuracy. Another requirement in the "Classify and ID" roles is a reduction in false alarm rates without a reduction in equipment sensitivity.<sup>78</sup>

The UUV Master Plan has provided additional requirements for the Littoral ASW SoS. A second set of requirements can be extracted from the UUV Master

---

<sup>77</sup> Donald C. Daniel, *Anti-Submarine Warfare and Superpower Strategic Stability*, University of Illinois Press, 1986, p. 89.

<sup>78</sup> J. R. Hill, RADM, USN, *Anti-Submarine Warfare*, Naval Institute Press, Maryland, 1985, pp. 46-47.

Plan. With the goal of a “higher Technology Readiness Level (TRL)” in mind, the requirement would be to “transmit RF data reliably in operational states,” whether it is in real or non-real time. Figure 25 explains what technological concepts will generate these requirements in the future. These same technological concepts should be considered as requirements that are necessary to meet today’s SoS needs, and are listed as:

- Improved classification
- Low power and automatic classification/ID
- Multithreat Chemical, Biological, Nuclear, Radiological, and Explosives (CBNRE)
- Intelligence, Surveillance, Reconnaissance (ISR) Specific Emitter (SEID)/Visual ID (VID)
- Non-Traditional Tracking (NTT) ASW

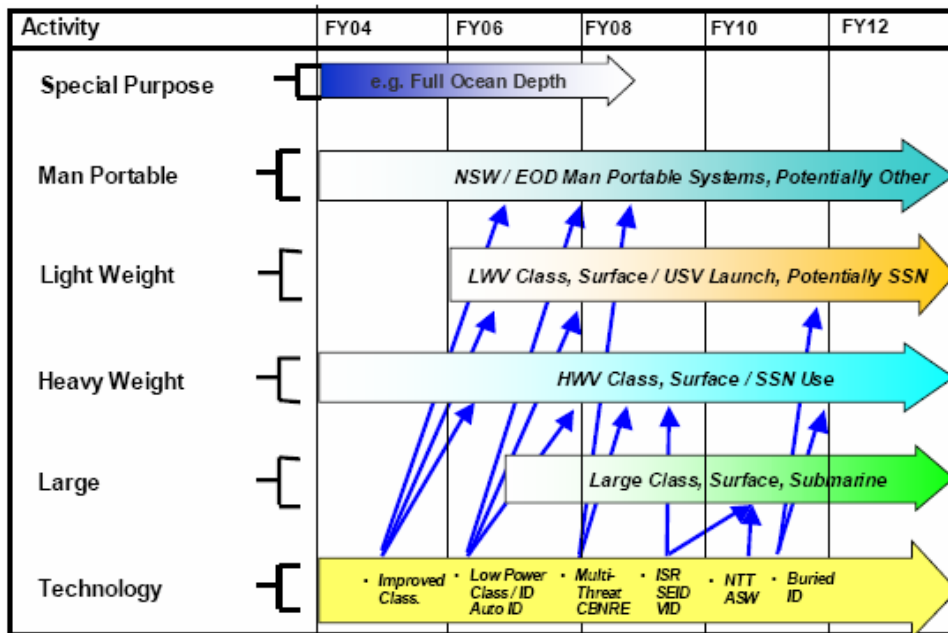


Figure 25: Technology Roadmap for Sensors<sup>79</sup>

The “improved classification” and “ISR/SEID/VID” requirements stem from the future containing a higher number and different types of vessels, from unmanned systems to manned and quieter systems, and the sensors’ ability to detect these systems using unconventional (or nontraditional) detection methods. The ability to

<sup>79</sup> *The Navy Unmanned Underwater Vehicle (UUV) Master Plan*, 9 November 2004, p. 77.

classify future underwater systems becomes crucial in order to accurately determine what the battlespace contains and the threat involved.

The “low power classification/ID” and “auto ID” requirements are directly related to the fact that enemy underwater assets will be quieter, use less power, and potentially carry more dangerous weapons. It then becomes crucial to keep the user out of the direct path of the threat and use automation as much as possible. This requirement also means that the sensor used to detect, track, and classify has to be low power in order to avoid rapid detection by the enemy.

The “multithreat CBNRE” requirement simply means that all sensors must be able to detect any type of threat, whether the threat is an actual contact or a weapon itself. The future may be limitless when it comes to weapon classification, and the sensor’s ability to detect any type of weapon will be crucial.

### 2.2.3 Requirements for PDT (Defeat)

In order to fully address the stakeholders’ needs, the PDT researched what requirements were to be applied during the design of the SoS for Littoral ASW in 2025. Emphasis has been given to those functions of the Functional Hierarchy for which the PDT is responsible, as shown in Figure 26.

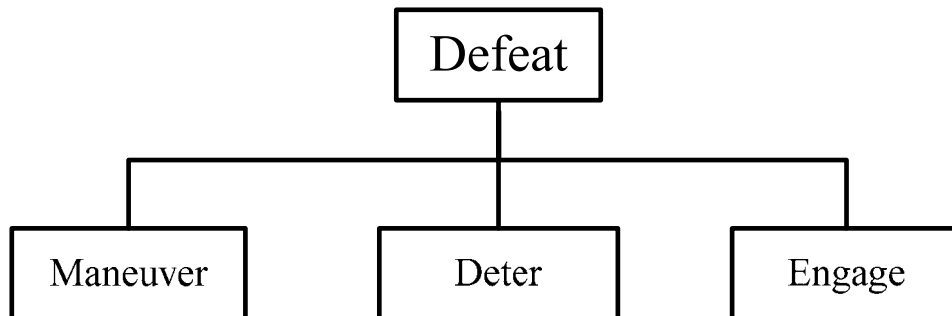


Figure 26: Functional Hierarchy for Defeat

#### 2.2.3.1 Maneuver

In order to satisfy the Maneuver subfunctions of Defeat, the SoS components and architecture must be able to:

- Collaborate with friendly assets for complimentary effect
- Use environment and topography for our advantage

- Perform overt and clandestine operations in areas inaccessible to conventional naval and maritime forces
- Arrive on station with minimal chance of detection
- Operate without a need for detectable communication
- Assess critical oceanic environmental data, and decide and act based on received information, without higher level input or feedback necessary

#### ***2.2.3.2 Deter***

In order to satisfy the Deter subfunction of Defeat, the SoS components and architecture must be able to:

- Conduct show of force operations with the intent to dissuade enemy opposition or movement
- Perform overt actions taken to force, or control, enemy maneuvers
- Establish preset tripwires and follow-on consequential actions that control enemy assets at a safe distance from allied forces
- Prohibit enemy assets from leaving port, from approaching friendly HVUs within a given range, or from conducting operations within a given area of concern

#### ***2.2.3.3 Engage***

In order to satisfy the Engage subfunctions of Deny, the SoS components and architecture must be able to:

- Neutralize or disrupt the enemy's ability to perform desired mission
- Assess enemy battle damage to determine the enemy's ability to operate

#### ***2.2.3.4 Stakeholder Interoperability and Compatibility Platform Requirements***

The SoS architecture must be capable of performing both overt and clandestine operations in areas inaccessible to conventional naval and maritime forces. The system should be capable of arriving on station with minimal chance of detection and operating without a need for detectable communications. In order to maneuver for

advantage, the system must be capable of sensing the ocean environment's critical data as well as assess, decide, and act based on received information, often without higher-level input or feedback.

In order to deter hostile enemy action, the SoS must be capable of communicating an escalation of tensions to the enemy. This deterrence may be used to prohibit enemy assets from leaving port, from approaching friendly HVUs within a given range, or from conducting operations within a given area of concern. For example, overt trailing may be performed to inform the enemy of successful tracking by our forces, thereby forcing them to evade to another operating area. ASW traps may be overtly established at the exits of primary ports to deter the enemy from getting underway.

Deterrence also refers to the CONOPS that must be established to respond to enemy action. Tripwires are events that require a friendly force response. Events such as an enemy submarine approaching within a given distance from US maritime assets or a loss of contact with a submerged threat are examples of operational tripwires. Tripwires must be established, and appropriate action assigned, to ensure that our advantage is reestablished and maintained if tripwires are violated.

The system must have the ability to respond offensively, if necessary. This may be manifested in the system's ability to damage or kill the enemy assets. However, other options may be pursued. Weapons used may disrupt the environment to such an extent that continued operation by the enemy becomes impossible. Another possibility may be to use a weapon that would prevent the enemy from prosecuting (detecting and tracking) or firing on friendly assets. Additionally, the SoS should be capable of accomplishing missions in any littoral region without the assistance or support of local nation-states.

The system must be sustainable for at least 30 days in the mission sea space while maintaining area prosecution and performing ASW barriers for three ports within 200 NM of each other.

As the development of unmanned technology evolves, systems should be considered to improve existing ASW performance. These unmanned systems may be required to avoid detection and be able to resist attack and countermeasures which will

allow penetration of denied areas for sustained independent operations.<sup>80</sup> In order to provide cost-effective and flexible capabilities, any UUV system alternative should strive to maximize modularity for the vehicles within given classes to facilitate industry standards and open architecture. Modularity will be a key aspect of the SoS to ensure its long-term functionality and operability with legacy platforms. In order to ensure modularity, the following standardized sizes must be used, as defined in the UUV Master Plan.<sup>81</sup>

- Man-Portable: approximately 25-100+ lbs displacement
- LWV: approximately 500 lbs displacement
- HWV: approximately 3,000 lbs displacement
- Large Class: approximately 20,000 lbs displacement

#### **2.2.4 Requirements for Command**

C4ISR requirements for the SoS that support specific functions needed for overall operation and coordination are Communicate, Network Data, and Exchange ISR.

A survivable real-time C4ISR system architecture is central to successful ASW. These systems must be capable of sharing and providing a clear and complete picture of the undersea environment and allow operators to assimilate tactical information rapidly and efficiently. These systems must also be a part of Joint and Service information networks to include sensors and networks deployed from aircraft, ships, submarines, and off-board vehicles. Through ForceNet, effective integration into these networks allows the ASW SoS to share situational awareness, plan collaboratively and fight synergistically with other Joint Forces. Key amongst these requirements is connectivity between systems, including the ability to communicate from below the surface, at tactically useful speeds, to facilitate exchange of time-critical information for situational awareness and enemy engagement.

---

<sup>80</sup> Department of the Navy, *The Navy Unmanned Undersea Vehicle (UUV) Master Plan*, 9 November 2004, p. 2.

<sup>81</sup> Department of the Navy, *The Navy Unmanned Undersea Vehicle (UUV) Master Plan*, 9 November 2004, p. xvi.

#### ***2.2.4.1 Communicate***

Effective C2 is impossible without timely and accurate communications. Commanders must be able to receive information and convey orders efficiently and seamlessly to all units engaged in an operation. Nowhere is this more important than in the execution of an ASW mission. All platforms, sensors, and weapons systems must be reliably linked to facilitate efficient secure C2. To this end, external ASW communication systems shall transmit and receive communications data by exploiting the full range of the electromagnetic spectrum. Units engaged in ASW must also have the ability to communicate efficiently within their platform. Much like external communications, internal circuits shall have the ability to transmit and receive information for distributed awareness. Processing VoIP data shall be required, where necessary, for the use of external and internal voice communications.

External C2 communication networks shall be conducted through traditional “above water” methods of radio broadcast via terrestrial and satellite-based communications; however, tomorrow’s ASW battlefield includes a much greater reliance on UUVs. To serve the latter, future communications networks must also have the ability to work at tactically significant ranges underwater.

Future systems must find ways to exploit the EM spectrum and other possible mediums to enable “underwater” communications networks. Due to the unique challenges inherent in underwater operations, communication systems must be robust and redundant enough to operate anywhere in the world, connecting all joint forces as well as many of our allies. For this reason, communication systems shall support transmissions and reception for the following communication requirements.

- High Bandwidth Air/Space Line of Sight (LOS)
- LOS data
- LOS voice
- Over-the-Horizon (OTH) data
- OTH voice
- Satellite Communications (SATCOM)
- Underwater data



Within manned systems, units shall support communication between personnel within the same unit and facilitate improved man-machine interfaces. The internal communication system shall:

- Transmit and receive directed information
- Utilize the unit's internal access network
- Interface with wireless network system
- Have redundant hardwired alternate communication networks

In order to satisfy the Communicate subfunction of Command, the SoS components and architecture must be able to:

- Provide timely and accurate communications
- Provide real-time connectivity between systems and platforms
- Communicate from below the surface, at tactically useful speeds to facilitate exchange of time-critical information for situational awareness and enemy engagement
- Receive information and convey orders efficiently and seamlessly to all units within the AOR
- Provide a secure and reliable link to facilitate efficient C2

#### ***2.2.4.2 Network Data***

The SoS will participate in the ForceNet concept. To support network-centric operations, the future system shall utilize a unit's distributed internal access networks and external communication capabilities to capture, process, interface, and secure information assurance. An increasing amount of networked tactical data is expected to be in the form of text, VoIP, recorded data, sensor targeting, fire control data, text command instructions, and images. To support a robust data exchange within the SoS, this system shall be equipped with a distributed internal access network of computing systems and integrated operator displays that interface with external wide area battlespace networks.

Battlespace networks are projected to exist on many levels above and below the sea. The following requirements support overall network information data functions:

- Capture requested unit-specific information for external air and underwater battlespace networks
- Process shared network information to promote C2 information fusion and C2 directed orders
- Interface unit's internal access network with external battlespace networks
- Secure network information data through multilayered information assurance

Each system shall operate a distributed internal access network for onboard C2, communication, and collaboration. The internal access network shall be:

- Composable and secure
- Distributed throughout the unit and on operators
- Support unclassified and classified information
- Interface with the SoS undersea warfare C4I Wide Area Network (WAN)
- Support Audio Video Teleconference data exchanges

The data exchanged as battlespace information to all SoS shall include the following requirements. Additionally, it is important to note that although "Exchanging ISR" has been identified as a subfunction for the SoS C4ISR, ISR is listed below as information used by and modified by operators.

- Unit status
- Advanced Video Conferencing (AVTC)
- Weapons Control Doctrine
- Remote Weapons Systems Control
- Sensor detection and tracking data
- Legacy link information
- Positional and navigational data
- Targeting and fire control data
- Remote unmanned vehicle control
- Information Assurance Doctrine
- ISR

In order to manage the large amounts of battlespace information received and transmitted by the system, each system unit shall have robust, controllable computing systems to filter noncollaborated warfare information. The C2 Fusion System shall:

- Interface with a unit's internal access network and distributed control system
- Operate with automaticity unless overridden by operators
- Collaborate battlespace information within the WAN
- Filter noncollaborated battlespace information
- Control organic and inorganic units and weapons systems
- Interface with distributed sensor fields
- Interface with Joint C2 fusion systems
- Unite unit sensor, fire control, and positional data from organic and inorganic systems for a cooperative battlespace environment
- Be information-assured and secure
- Utilize and control legacy link information

In order to satisfy the Network Data subfunction of Command, the SoS components and architecture must be able to:

- Support network-centric operations
- Interoperate with protocols established under the ForceNet concept
- Transmit and receive at tactically significant ranges underwater
- Transmit and receive across a broad spectrum of water space to include varied temperatures, salinities, and currents
- Capture requested unit specific information for external air and underwater battlespace networks
- Process shared-network information to promote C2 information fusion and C2-directed orders
- Interface existing unit internal access networks with external battlespace networks
- Secure network information data through multilayered information assurance

- Utilize and control legacy link information

#### ***2.2.4.4 Exchange ISR Data***

Accurate and timely ISR is a critical force multiplier for ASW. Exchanging ISR information is designated as a separate function due to its importance and time critical nature. It is imperative that a future SoS USW system is able to transfer intelligence data, surveillance data, and reconnaissance data. To support an exchange ISR function, the SoS shall:

- Operate with an autonomous ISR sharing system
- Automatically transfer raw electronic sensor data to a designated battlespace network for collaboration
- Automatically inject collaborated ISR information to the battlespace common operational/undersea picture
- Accept and process human intelligence input

### **2.3 OBJECTIVES ANALYSIS**

An Objectives Analysis was performed in lieu of a Value Systems Design (VSD). The Objectives Analysis develops objectives based on system functions as identified in the Needs Analysis phase, while avoiding some of the more controversial aspects of VSD. Stakeholders often have differing viewpoints about what objectives to pursue and which objectives are most important. Developing accurate objectives based on the VSD method often adds a great deal of complexity, especially when stakeholders are ill-defined or are difficult to meet with on a regular basis.

Objectives Analysis identifies metrics that will be used to evaluate system performance based on the system's characteristics, not just stakeholder input, and is therefore better for the SEA-8 specific project.

An Objectivity Hierarchy is major component and product of the Objectives Analysis. The Objectives Hierarchy is an organized picture of what the stakeholder intends to accomplish with a given project or program.<sup>82</sup>

---

<sup>82</sup> Andrew P. Sage and James E. Armstrong, Jr., Introduction to Systems Engineering, (New York: John Wiley & Sons, Inc., 2000) p. 104.

The Objectives Hierarchy is a continuation of the Functional Hierarchy conducted during the Functional Decomposition phase of the SEDP. The Objectives Hierarchy is a pictorial structure illustrating the relationship between the revised effective need, major critical functions, subfunctions, objectives, evaluation measures, and goals for a given SoS. The Objectives Hierarchy utilizes the revised effective need, the major critical functions, and the subfunctions generated in the Functional Decomposition Phase to develop a set of objectives which specifically satisfy the major critical functions and the subfunctions of the system. The process continues by assigning each objective an evaluation measure(s) that explicitly states how the objectives will be evaluated. Finally, a goal is assigned to each evaluation measure to measure how well a proposed alternative meets that objective.<sup>83</sup>

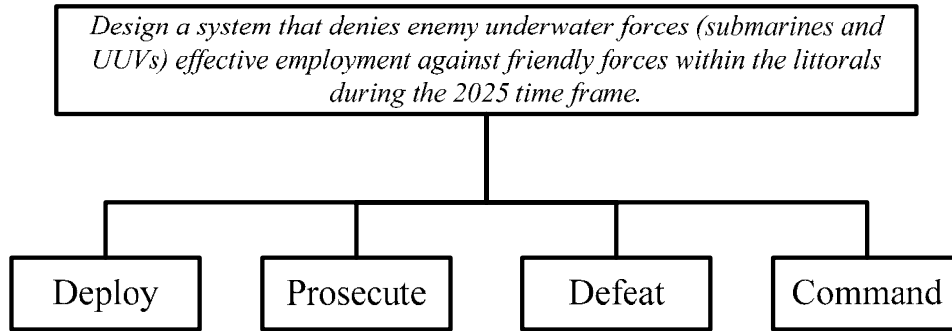
Once the evaluation measure(s) and goals have been assigned, the Objectives Hierarchy is checked to determine if it exhibits certain characteristics. Objectives Hierarchy completeness requires that all the evaluation concerns of our stakeholders are covered and that the evaluation measures selected adequately measure the attainment of the objectives. Next, nonredundancy needs to be ensured in the selected hierarchy. Evaluation considerations should not overlap. The value hierarchy requires *independence*; preference for the level of one evaluation measure should not depend on the level of another evaluation measure. Finally, the value hierarchy should be meaningful and understandable to the people who will use it (decision makers, functional experts, and other stakeholders).<sup>84</sup>

Beginning with the revised effective need statement and the overall critical functions of the SoS (Figure 27), each SEA-8 team began the Value System Hierarchy with objectives in mind to create a mutually exclusive and collectively exhaustive value hierarchy that would be meaningful to stakeholders, small in size, and independent. The MOEs developed are measurable, quantifiable, and directly related to the operational objectives. It was essential to ensure this hierarchy was reflective of the needs of SEA-8's stakeholders.

---

<sup>83</sup> Systems Engineering and Architecture 4001 Class Notes (Naval Postgraduate School, Monterey, CA, 2005).

<sup>84</sup> Systems Engineering and Architecture 4001 Class Notes (Naval Postgraduate School, Monterey, CA, 2005).



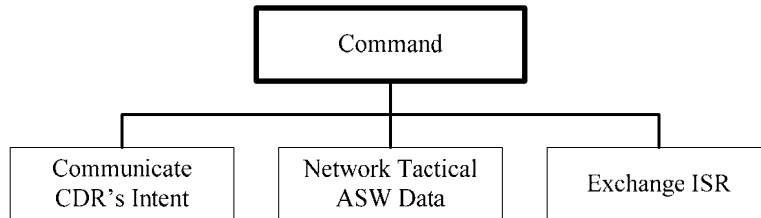
**Figure 27: Functional Hierarchy (SoS Critical Functions)**

Each SEA-8 team based their value hierarchy on the Gold Standard value model (necessary research was performed using appropriate documentation). Their research of fleet strategic objectives, current doctrine, and the latest CNO vision provided key input into this design process.

### 2.3.1 Objectives Analysis for Command

The objectives assigned below were derived based on the C4ISR Functional Hierarchy and C4ISR I-O Model analysis. An objective was assigned to each function in the Functional Hierarchy along with an MOE, a measure of performance (MOP), and a metric.

The overall goal of this Objectives Analysis was to produce a hierarchy of objectives that reflect the C4ISR Functional Hierarchy identified in Section 2.1.7.1 and support the overall C4ISR Effective Need statement. An exploration of system needs was then expressed in measurable quantities for the ultimately purpose of providing a foundation for evaluating alternative architectures that will be designed during the Alternatives Generation Phase of the SEDP. The three Command subfunctions (Figure 28) identified during the Functional Analysis phase of the SEDP are defined below.



**Figure 28: Command Subfunctions**

Evaluation measures for each objective were established to gauge the SoS's performance in each area. These evaluations represent metrics that complete each associated objective. Sections 2.3.1.1 through 2.3.1.3 detail each Objectives Hierarchy in figures (Figures 29, 30, and 31), where each one defines the objectives, evaluation measures, and goals of the Command subfunctions. Appendix A contains a complete list of Command's evaluation measures.

### 2.3.1.1 Communicate

This system must allow for the free flow of information throughout the chain of command, from the highest levels of strategic command to the lowest levels of tactical sensors' operators. This includes many methods of redundancy for exchange of information via text, audio, video, display, and visual means, all focused on human interaction. In general, it must have the ability to:

- Transmit and receive information and convey orders in a timely and accurate manner across a wide range of electromagnetic spectrums to a variety of platforms and units engaged or supporting strategic, theater or tactical actions
- Seamlessly and efficiently enact the CDR's intent

Figure 29 describes the "communication" objective's MOEs and MOPs:

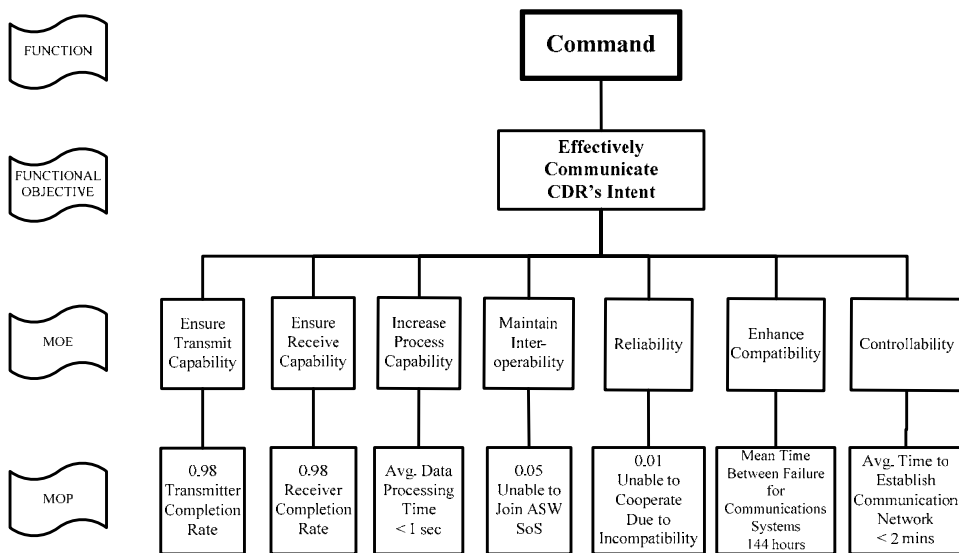


Figure 29: Communicate Objectives Hierarchy Analysis

### 2.3.1.2 Network Data

This system must be able to rapidly exchange data from numerous sensors, weapons, and platforms spread over thousands, if not tens of thousands, of miles in a tactically significant period of time. This calls for the seamless integration of sensor and weapons systems, and their associated communications systems, to produce a thinking field of networked sensors. In general, it must have the ability to:

- Utilize distributed external and internal access networks to transmit and receive data across a wide range of electromagnetic spectrums to a variety of platforms and units engaged or supporting strategic, theater, or tactical actions
- Capture requested unit specific information for external air and underwater battlespace networks and process shared network information to promote C2 information fusion and C2-directed orders. The SoS must also be able to interface internal access networks, with external battlespace networks while providing secure network data transfer

Figure 30 represents the “network data” objective’s MOEs and MOPs:

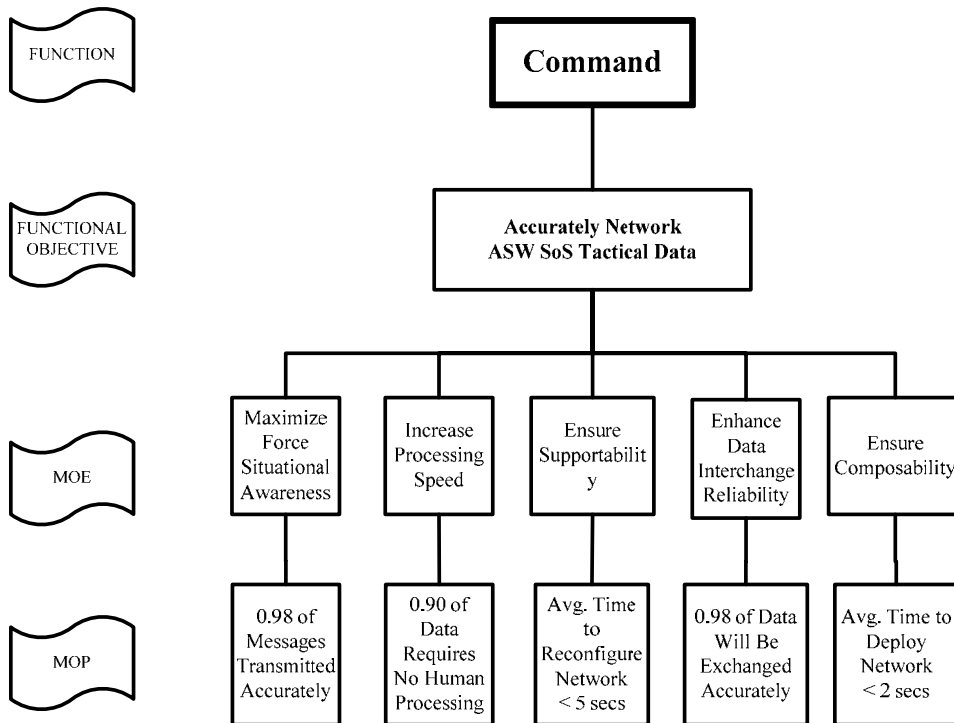


Figure 30: Network Objectives Hierarchy Analysis



### 2.3.1.3 Exchange ISR

In order to allow users to make sense of the raw data being received from deployed sensors, this system must also possess the ability to reach back to national resources and those of US allies. More specifically, this system must feed national assets the information gained from deployed sensors with regard to ISR information. In general, it must have the ability to:

- Accurately and timely transfer intelligence data, surveillance data, and reconnaissance data across a wide range of EM spectrums to a variety of platforms and units engaged in or supporting strategic, theater, or tactical actions
- Automatically transfer raw electronic sensor data to a designated battlespace network for collaboration and inject collaborated ISR information to the network in order to create a common operational/undersea battlespace picture

Figure 31 shows the ISR objective's MOEs and MOPs.

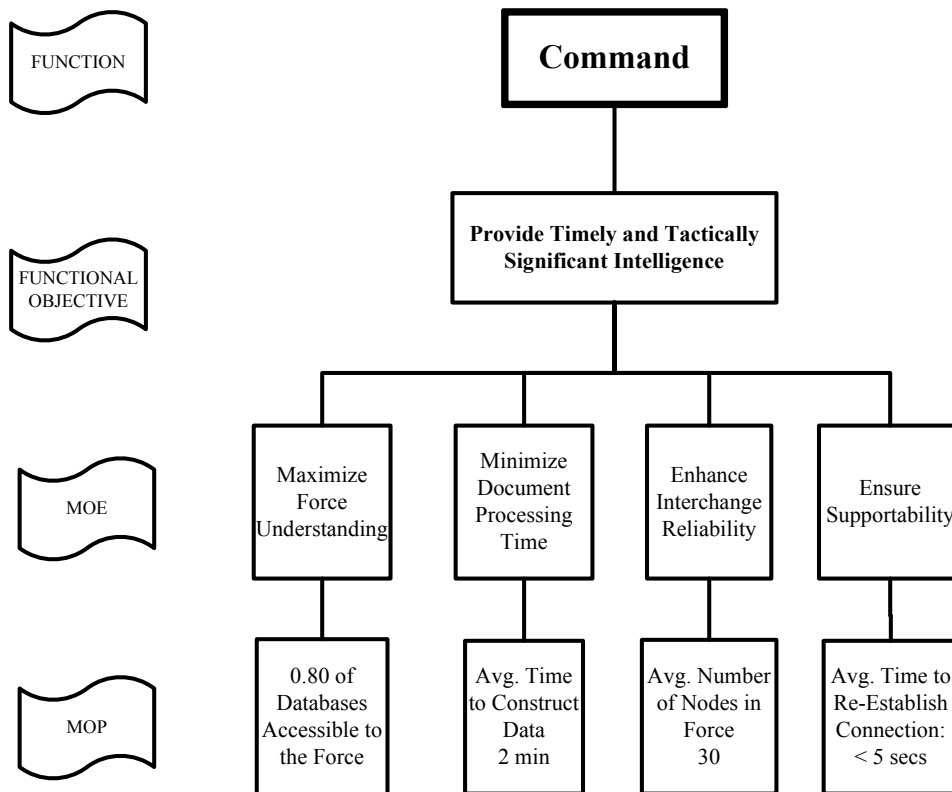


Figure 31: Transfer ISR Data Hierarchy Analysis

## **2.3.2 Objectives Analysis for Deployment**

Evaluation measures are derived to determine desired performance for each objective and its subfunction. From these individual measures, goals and quantifiable metrics are defined. The three Deployment subfunctions identified during the Functional Analysis Phase of the SEDP are defined in Sections 2.3.2.1 through 2.3.2.3. In general, it must have the ability to prepare, deliver, and sustain, as described below.

### ***2.3.2.1 Prepare***

- Be equipped for rapid deployment via air, surface, and subsurface assets external to the theater of operations
- Employ sensor components that require minimal maintenance and support requirements will ensure the highest readiness rate
- Achieve capability to deploy self-initiating sensors that are ready for operations on deployment

### ***2.3.2.2 Deliver***

- Interoperate with both legacy and future POR deployment systems. Modularity and interoperability will aid in development of a CUP
- Provide the sensor assets required to obtain, within 72 hours, a 0.8 Pd across a contested waterway (area not to exceed 1,000 NM<sup>2</sup>)
- Provide the sensor assets required to obtain, within 10 days, a 0.8 Pd across a contested AOR (area not to exceed 20,000 NM<sup>2</sup>)

### ***2.3.2.3 Sustain***

- Provide the logistical support necessary to sustain those assets already within the AOR for 20 additional days
- Provide capabilities through modular design to be replenishable via a variety of joint methods
- Supply and/or deploy and organically support SoS components (self-deploying platforms)

- Continue deployment of the full spectrum of SoS components to include UUVs and distributed network sensors and components (deployment platforms)

Using these subfunctions, the Objectives Hierarchy (Figure 32) is presented below:

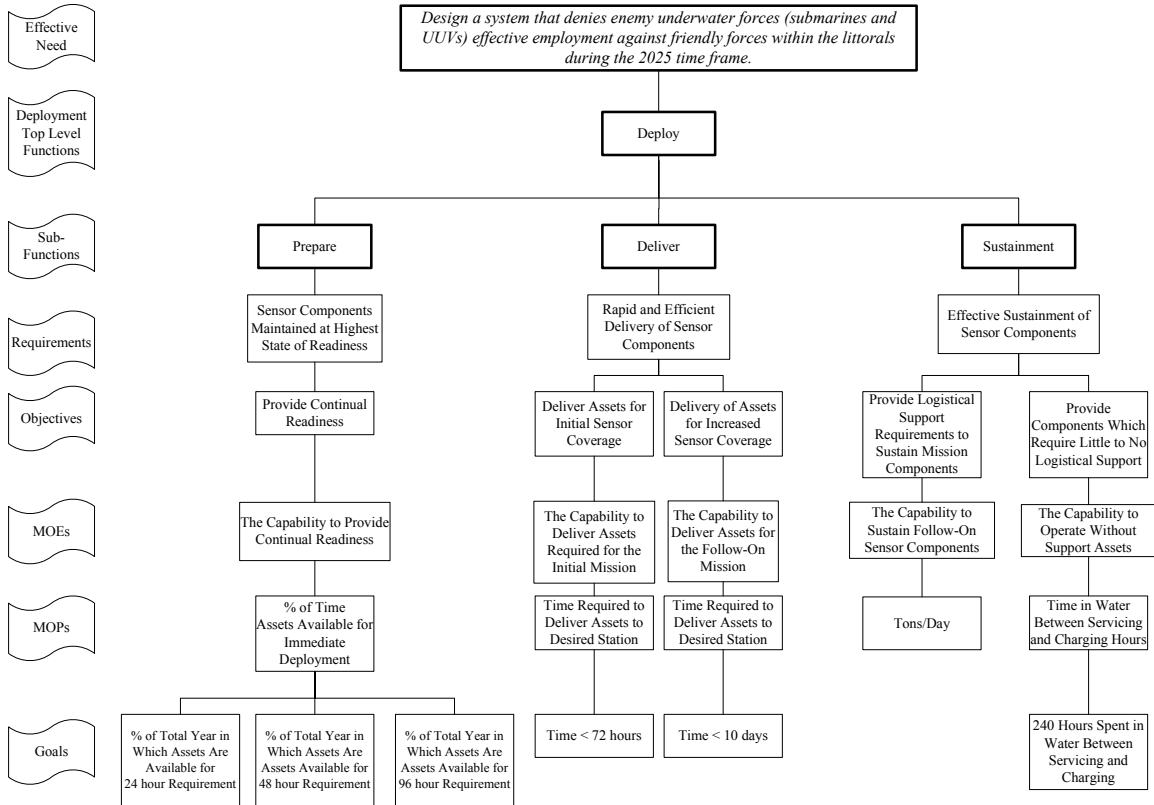


Figure 32: Deploy Functional Objectives Hierarchy

### 2.3.3 Objectives Analysis for Prosecute

In the Requirements Document, four sets of requirements were identified, with one set corresponding to each of the primary subfunctions (assess, search and detect, tracking, and classification). The requirements were then translated into objectives, MOEs, MOPs, and goals tied to the initial requirements that the SoS should achieve.

Initial analysis developed by the Sensors Team shows each of the subfunctions with their respective evaluation measures and goals. The goals listed in the initial assessment were refined through an iterative process to scope and bound the problem

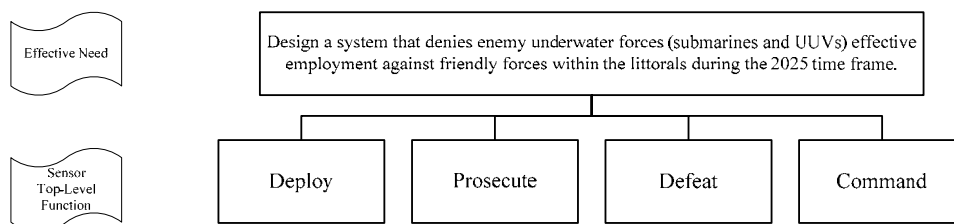
through the analysis of key parameters. These refined goals have been integrated via this process as inputs into the overall modeling of the SoS.

### 2.3.3.1 Initial Discoveries

The Objectives Hierarchy process started with the revised Effective Need statement and a Functional Hierarchy delineating Critical Functions of the SoS. In order to meet the effective need of “denying enemy underwater forces (submarines and UUVs) effective employment against friendly forces within the littorals,” it was determined that four functions must be reviewed:

- To deploy assets to the AOR
- To prosecute within the AOR using the deployed assets to discover the enemy
- To defeat the enemy through denial or destruction<sup>85</sup>
- To link the battlespace together via communications and networks

Figure 33 is a graphical representation of these four critical functions.

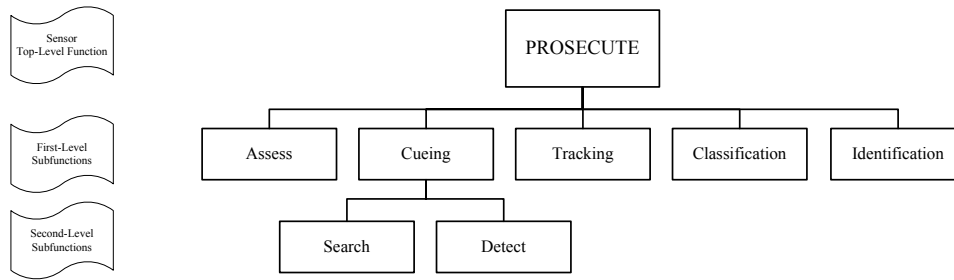


**Figure 33: Functional Hierarchy (SoS Critical Functions)**

Breaking down the “Prosecute” function by adding its subfunctions has been an iterative process for the Sensors Team. The initial study of the Prosecute function revealed several subfunctions including assess, search, detect, tracking, classifying, and identification. Research revealed that multiple ASW sources listed the search and detect sub-functions under one umbrella labeled “cueing.” Subfunctions analysis led the Sensors Team to delineate what is represented in Figure 34, showing the breakdown of the prosecute function into its subfunctions.

---

<sup>85</sup> CAPT Bill Toti, USN, *Full Spectrum ASW Campaign Plan*, Fleet ASW Command Norfolk, PowerPoint presentation, slide 6).



**Figure 34: Functional Hierarchy (Prosecute Subfunctions)**

The “assess” subfunction was important because knowing the environment before sensors are sent in to search and detect will aid evaluators by increasing the effectiveness of the sensors, estimating how many sensors to send in to an AOR, and knowing how long it would take the sensors to assess the environment of the operating area. Future assets may be able to program the environmental data into the sensor in order to maximize its effectiveness and produce less false alarms or unknowns. This can be done locally or via reach-back<sup>86</sup> (to CNMOC<sup>87</sup> or FNMOC<sup>88</sup>) in order to maximize effectiveness.

Cueing represents the main event for Sensors. Once the sensors are present in the AOR, the search and detect functions play the most critical role during the operations. The price of a sensor failing to conduct an exhaustive search and detect the enemy in their path could mean the difference between effective military operations or a tactical defeat.

Tracking, classification, and identification play key roles in the military operation. Once a contact has been cued, it is crucial that the sensor, or a communication node within the sensor, have the capability to track that contact at least until the contact has been successfully classified, and if needed, continue to track the contact until a FCS has been obtained by a friendly platform or weapon, or the contact is denied the ability to conduct their operations and turns away.

### ***2.3.3.2 Objectives Hierarchy Matrices***

Once the critical functions and subfunctions have been identified and documented, the systems engineering process continues through determining each

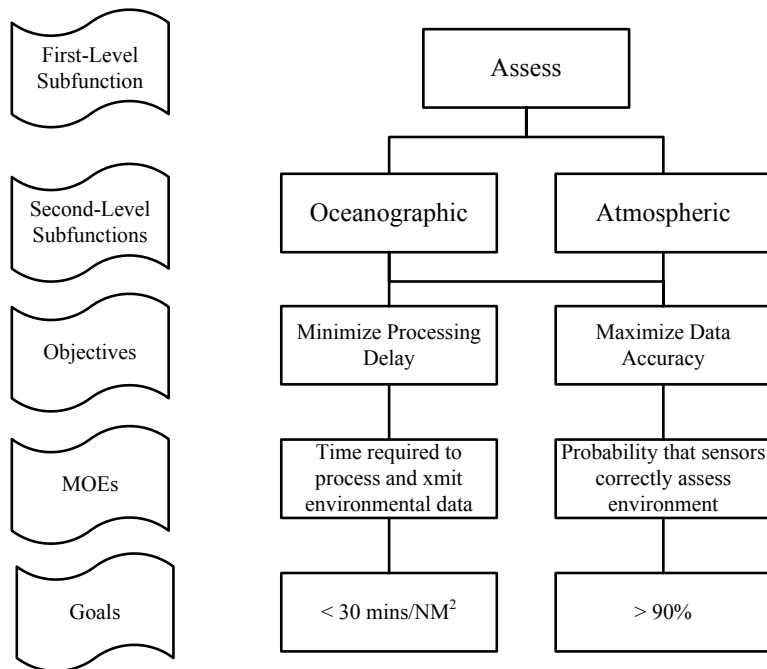
<sup>86</sup> [http://www.chinfo.navy.mil/navpalib/cno/n87/usw/issue\\_4/naval\\_ocean.html](http://www.chinfo.navy.mil/navpalib/cno/n87/usw/issue_4/naval_ocean.html), 13 October 2005.

<sup>87</sup> Commander, Naval Meteorological and Oceanographic Command.

<sup>88</sup> Fleet Numerical Meteorological and Oceanographic Command.

subfunction’s objectives and MOEs. Goals are assigned to each based on the requirement delineated in the previous section. Each of the five major subfunctions is represented below in individual charts. The subfunction of “assess” is represented in Figure 35, “cueing” is represented in Figure 36, “tracking” in Figure 37, “classification” in Figure 38, and “identification” is represented in Figure 39.

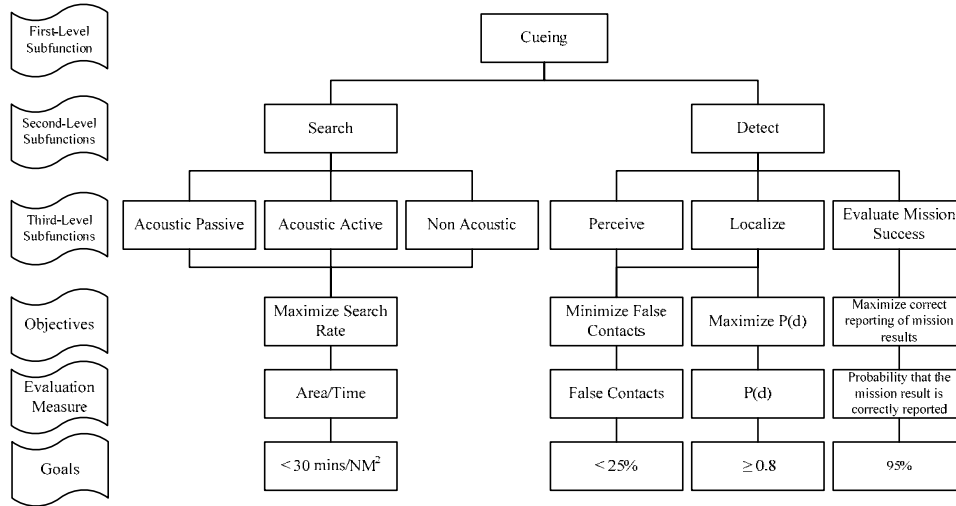
Understanding the oceanographic and atmospheric data in the OA is critical to sensor performance and in setting expectations for the ability of the sensor to meet or exceed the requirements of the SoS. Each of the second-level subfunctions has the same objective: to communicate the sensor’s findings accurately and with speed.



**Figure 35: Objectives Hierarchy for “Assess” Subfunction**

Initial goals in the area of “assess” include the ability to assess the environment with a speed of no less than 30 minutes per NM (which, based on the sensor’s platform speed, may require only a sampling of the data in the AOR and a generalization of likeness to the remaining area), along with a minimum of 90% accuracy. The goals were established based on the requirement of the sensors being able to provide an “on-demand” environmental assessment. Therefore, it is not only important for the data to be accurate, it must be transmitted in a way that other platforms or sensors can effectively use the data in a timely manner—one that does not interfere or slow down other operations.

Figure 36 details the objective hierarchy for “cueing.” As mentioned earlier, cueing is an important subfunction for the primary critical function “prosecute.” As can be seen in the graph, cueing is broken down into two second-level functions: search and detect. Each second-level subfunction has a unique set of third-level subfunctions that combine to form the objectives and the goals for cueing.

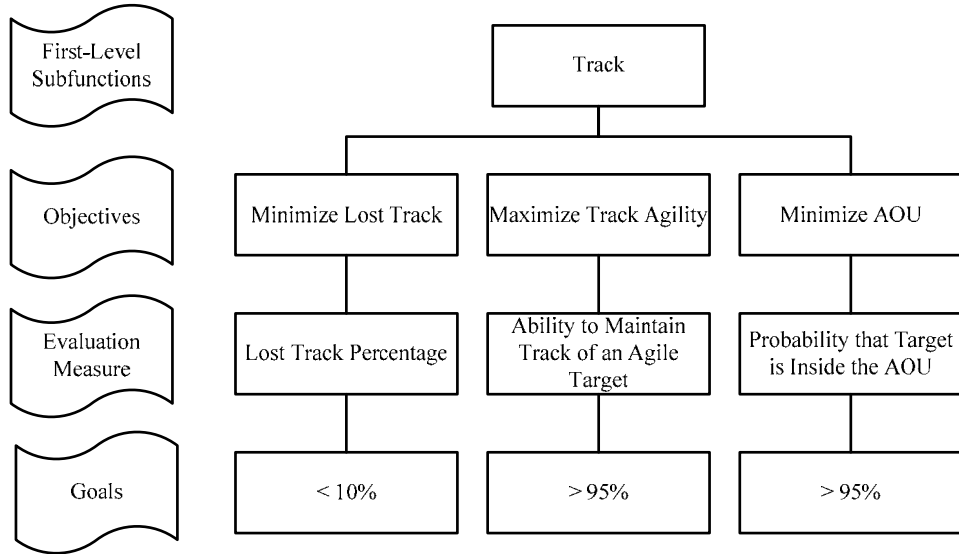


**Figure 36: Cueing Objectives Hierarchy Analysis**

The third-level subfunctions, objectives, evaluation measures, and goals listed in Figure 36 tie in directly with the Needs Analysis section. The “search” subfunction is exhaustive since it includes active and passive acoustic and nonacoustic search methods. Once the search method has been identified, the goal then becomes to search at a rate that will provide the operational commander search data with sufficient time to respond. Speed (search rate) and accuracy (minimize false contacts and maximize probability of detection) are the most important aspects of search and detect because these sub-functions are at the front end of the detect-to-engage process. Follow-on action taken by the operational commander will depend on the results provided by this function.

The tracking subfunction is depicted in Figure 37, along with its objectives, MOEs, and goals that were initially determined to be critical for this subfunction. Included in the subfunction “tracking” is the ability of the sensor to maintain the active or passive real-time information on the contact without the “sensing” portion of the process being lost, and therefore not knowing where the contact is. Tracking is a key sub-function because it gives the SoS two critical elements: (1) time for the SoS to classify the contact as a contact of interest; and (2) time that permits the operational

commander to generate a FCS, which may be required to entice the enemy to depart the OA (as a deterrent), or to destroy the enemy.

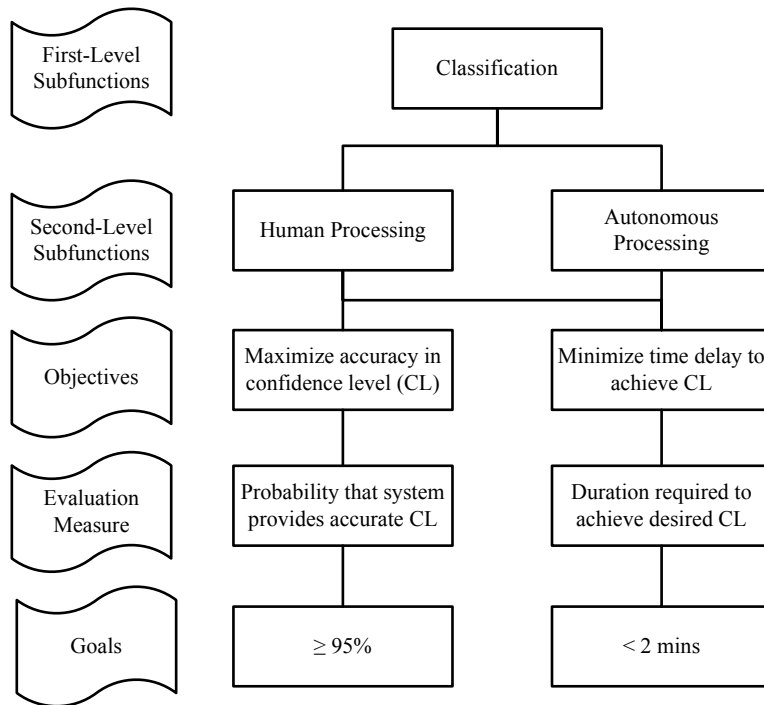


**Figure 37: Track Objectives Hierarchy Analysis**

As can be inferred by looking at the goals in Figure 37, it is important for the SoS to have the ability to maintain a strong track on a target that is moving (agile) to ensure that what the sensors are looking at can be classified, giving the system enough time to generate follow-on required actions.

The last two objective hierarchy matrices (Figures 38 and 39) cover the classification and identification subfunctions of Sensors. Classification (Figure 38) includes the ability to establish, with a high degree of confidence, that what is encountered in the water is, in fact, a submarine or an underwater threat. Classification is broken down into four distinct categories: CERTSUB, PROBSUB, POSSUB, and NONSUB, as defined in Appendix F.

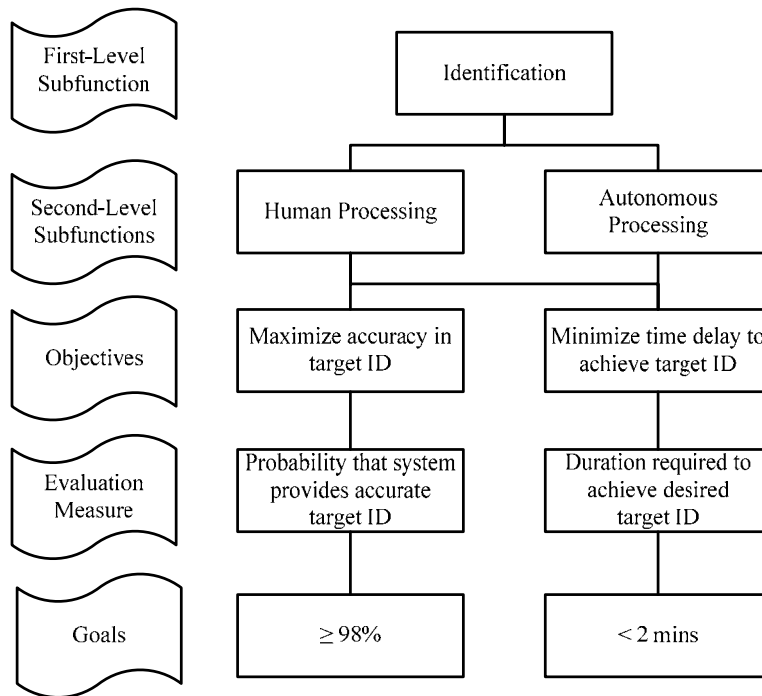




**Figure 38: Classification Objectives Hierarchy Analysis**

As shown above, the goals of classification include a high degree of accuracy (as seen throughout all of the subfunctions) and information provided in a timely manner. Both classification and identification share the objective of becoming autonomous processes. For autonomy to exist, the SoS must include processes to classify based on received signal strength as well as be able to compare sensed signals to an existing library of sound profiles of friendly and enemy force underwater assets and make an identification with a certain degree of confidence, passing that information on to the operational commander and to weapon systems that use the information to generate FCS.

The identification objective hierarchy matrix can be found in Figure 39. The autonomous subfunction is identical to the one found under classification, but the human processing side requires a user to decide if the information provided by the sensor and the sound profile discovered in the underwater detection matches, with a high degree of certainty, a specific friendly or enemy asset—mainly UUV and submarine types.



**Figure 39: Identification Objectives Hierarchy Analysis**

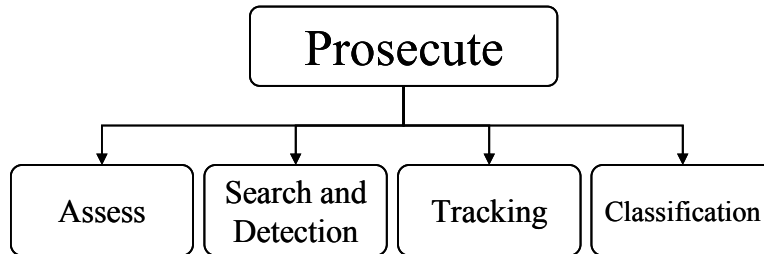
Sound profiles detected underwater can be matched to existing databases, and the sensor’s processing can determine if the sound profile matches existing signatures in the database, but the degree of certainty comes into play when more than one match occurs for the same sound profile. This is where the user is interfaced with the data provided by the sensor.

### ***2.3.3.3 Tying Requirements to Objectives***

Because the SEDP and the Systems Engineering processes are iterative, the ultimate goal of these processes is to tie the requirements established by the stakeholders to the objectives that the systems engineers discover within the effective need. In this section, the requirements are tied back to the objectives and goals, and the functional hierarchy changes slightly to better bound and define the solution. This, in turn, will drive the modeling phase of the SEDP.

The final agreed upon functional hierarchy is represented in Figure 40. The “assess” function takes on the responsibility of what the operational commander defines as the recognized maritime picture (RMP). RMP, however, has two facets. The first is an understanding of the environmental data in the OA, while the second comprises

a thorough knowledge of the surface, subsurface, and tactical air situation. The “assess” subfunction will uncover only the environmental data, while the tactical data will be included in the second critical subfunction “search and detection.”

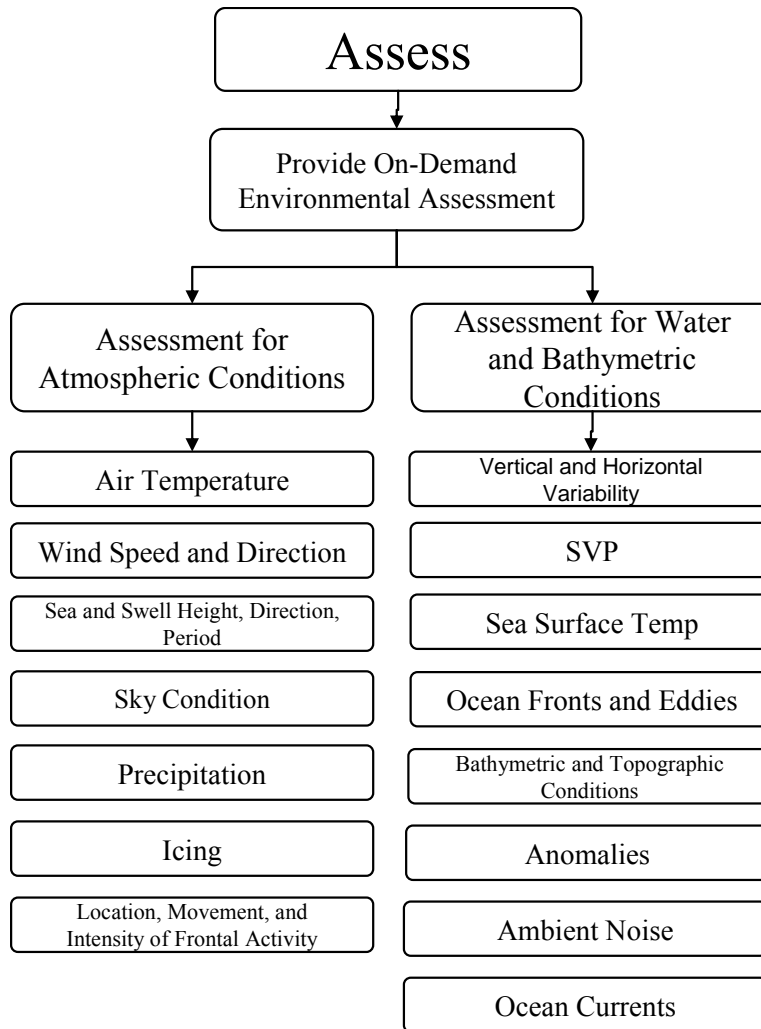


**Figure 40: Revised Functional Hierarchy for “Sensors”**

The “identification” subfunction was removed from the original functional hierarchy. “Identification” is not being addressed for reasons previously stated in this section. The goal of the system is to establish a tripwire. Follow-on action, such as weapons release, will be determined by a different system.

#### **2.3.3.4 Assess**

Beginning with “assess,” Figure 41 shows the requirements as found in the Requirements Document. The purpose of revisiting the requirements in this document is to ensure that the requirements are being reviewed as part of the SEDP iterative process and to ensure that the objectives tie in to the requirements as set forth by the stakeholders.

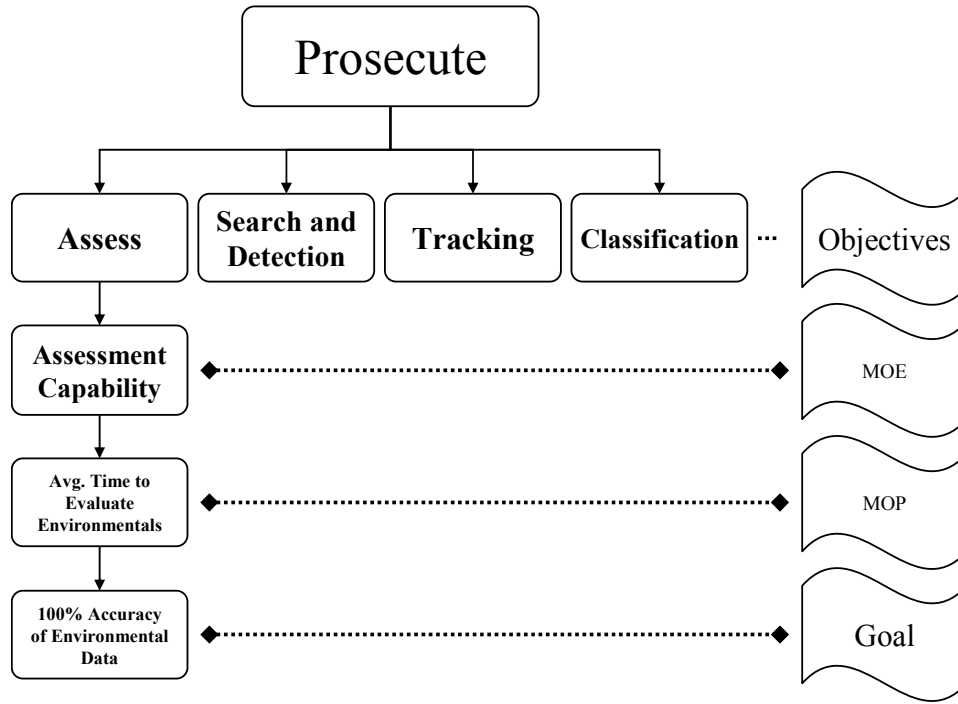


**Figure 41: Requirements Summary for “Assess” Subfunction**

The “assess” data, mainly environmental (oceanographic and atmospheric) data, can be provided through a sampling of the ocean and atmosphere in the OA by an unmanned sensor. Examples of today’s unmanned sensors used for sampling environmental data are known as “gliders,” but they are still in development. With a top speed of 1 knot, no need for fuel, and the ability to communicate via satellite once a day,<sup>89</sup> gliders can provide the data required for the operational commander to use in order to determine the best sensor mix and efficiency that will be obtained in follow-on responses.

<sup>89</sup> David L. Martin, Ph.D., CAPT, USN (Ret.), *NPS Menneken Lecture Series* “Persistent Littoral Undersea Surveillance: The Role of Undersea Gliders,” Applied Physics Laboratory, University of Washington, 6 October 2005.

As represented in Figure 42, the objective under “assess” is to develop a SoS that has the ability to assess environmental data in the OA in a manner that provides the operational commander sufficient information to enable successful follow-on actions.



**Figure 42: Revised Objectives Hierarchy for “Assess” Subfunction**

The MOE is determined as the capability of the SoS to assess the environment in the required time frame. The MOPs are the average time the sensor takes to evaluate the environmental data retrieved during the assessment phase and the accuracy of the data being retrieved. One of the goals of the SoS is to provide this data to the end user, with 100% accuracy.

Retrieving environmental data for follow-on use by other sensors is becoming more and more important in developing tactics to defeat underwater assets. Currently, gliders (UUVs equipped with environmental data sensor devices) perform the mission of “assess” with several drawbacks. They are still being tested, and are limited in speed and battery strength, thus depending on currents and internal buoyancy mechanics to travel through the water.

In 2025, it is feasible that a better understanding of the underwater characteristics will lead to models that accurately predict needed characteristics (and stay current with changes occurring in the environment) and can be available for retrieval and

use by the operational commander. The “assess” function then becomes a mere download where the end user can upload the environmental characteristics into the underwater sensor. It is also feasible that more advanced sensors will be able to deploy to the OA and conduct an assessment within the required time frame, with the ability to self-propel and navigate underwater without depending on currents and buoyancy physics.

### ***2.3.3.5 Search and Detect***

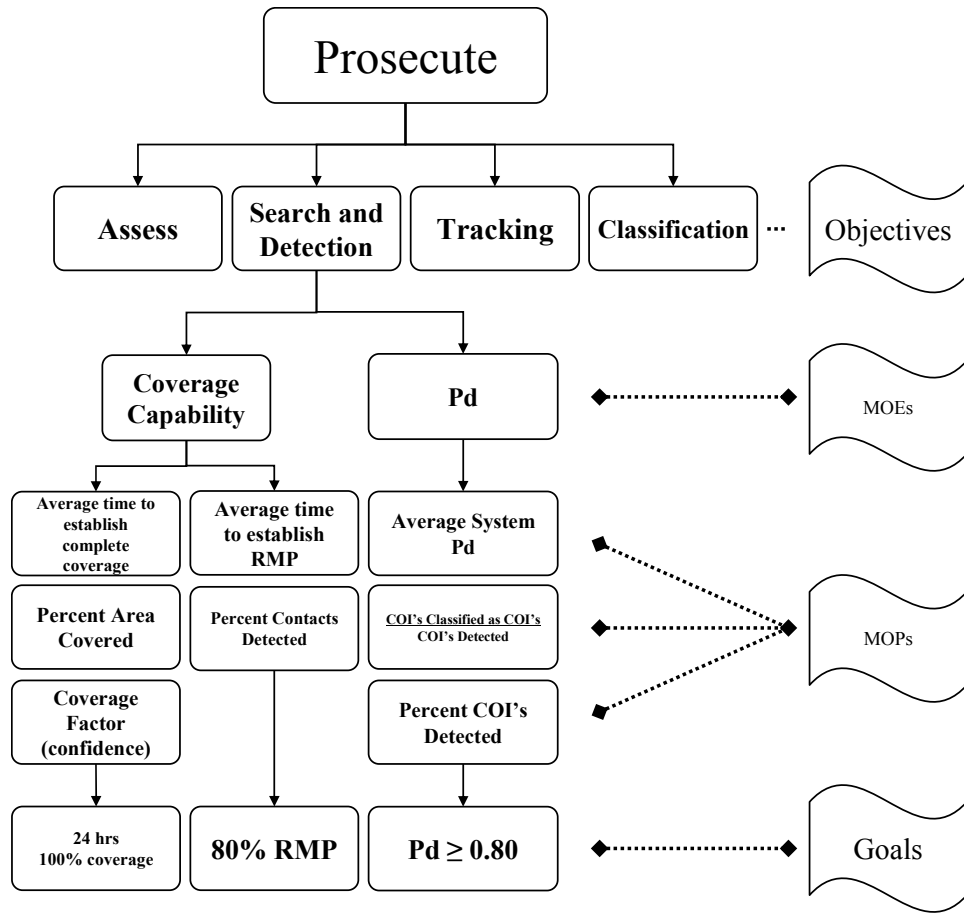
RMP has two facets. The first is to understand the environmental data, and the second is to have good situational awareness of the contact picture—where the vessels, submarines, and aircraft are located in the AOR. The first facet is accounted for in the “assess” subfunction and the second in the “search and detection” subfunction under the MOE of coverage capability. The sensor employed for search and detection should have the capability to assess the RMP facet that involves shipping.

The “search and detection” subfunction is divided into two separate parts, as can be seen in Figure 43. The first part examines the existing surface/subsurface/air contact picture (RMP), and the second part covers the Pd aspect of detection. The primary objective of the subfunction “search and detection” is to search for and detect COIs within the AOR. The two MOEs selected under search and detection deal directly with a sensor’s ability to detect a contact.

Several MOPs can be drawn from the single MOE because of the complexity of the problem of detecting everything that is in the AOR. The MOP of average time to establish complete coverage (100% area covered) is the ability of the sensor to have searched the entire OA within the goal of 24 hours.<sup>90</sup>

---

<sup>90</sup> This goal is drawn from a parameter of 96 hours for operations to commence once an order is issued, to 72 hours for assets to arrive on station. Subtracting the two numbers is what time is available to determine the RMP for the OA and have a better idea of what might interfere or preclude the operations from taking place, with a specified coverage factor or confidence level as specified by the operations.

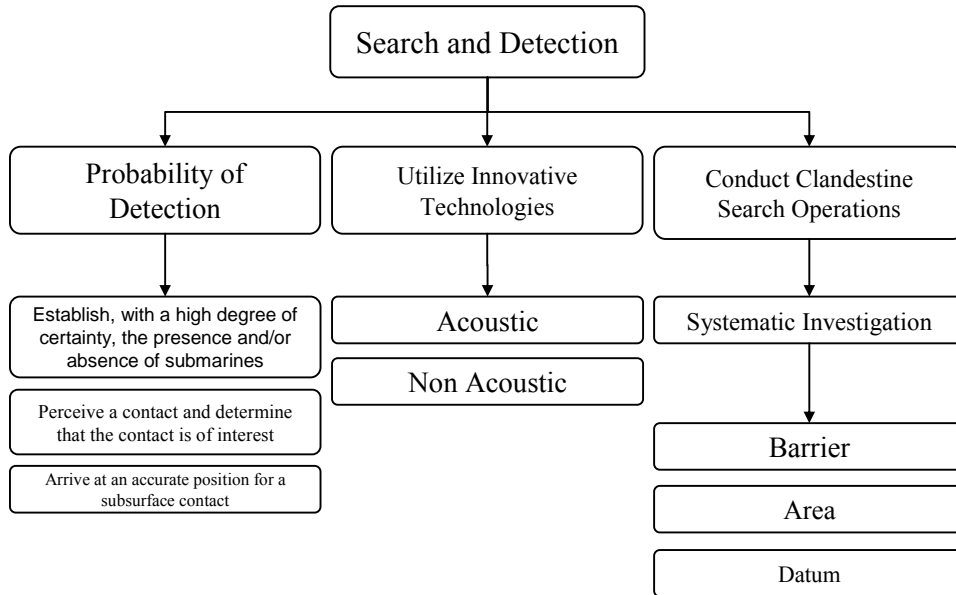


**Figure 43: Revised Objectives Hierarchy Matrix for “Search and Detection” Subfunction**

Search and Detection has three general requirements, as shown in Figure 44. The first requirement is the Pd, and represents the crux of the problem defining Sensors. The Pd relies on the sensors’ ability to achieve the 80% RMP goal listed in Figure 43 as well as search out and detect COIs and critical COIs (CCOI).

Additional requirements include achieving the Pd using innovative technologies and during clandestine operations. The Pd is an important requirement and MOE (as listed in Figures 43 and 44). It is imperative that, during an operation, the combatant commander should have the ability to establish, with a high degree of certainty, whether or not submarines are present in the AOR. This is going to depend on the sensors, sensor strength and accuracy, and how the sensors are affected by the environment. Once an underwater signal has been detected, the sensor must compare the signal to existing criteria and determine if the contact is a COI or not, and if not, determine what produced the signal that was encountered. After the underwater signal

has been correlated to a COI, the mission becomes determining the location of the contact.



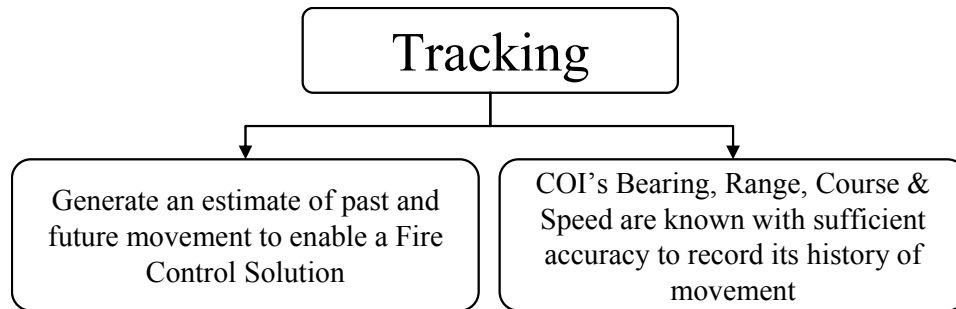
**Figure 44: Requirements for “Search and Detect” Subfunction**

A COI is going to operate in a different way than a normal ship or fishing boat. Enemy underwater threats are going to be quieter, stealthier, and take measures to avoid detection. While the detection of assets on the RMP side is for situational awareness, the Pd goal of greater than or equal to 80% is concerned strictly with enemy underwater threats.

### ***2.3.3.6 Tracking***

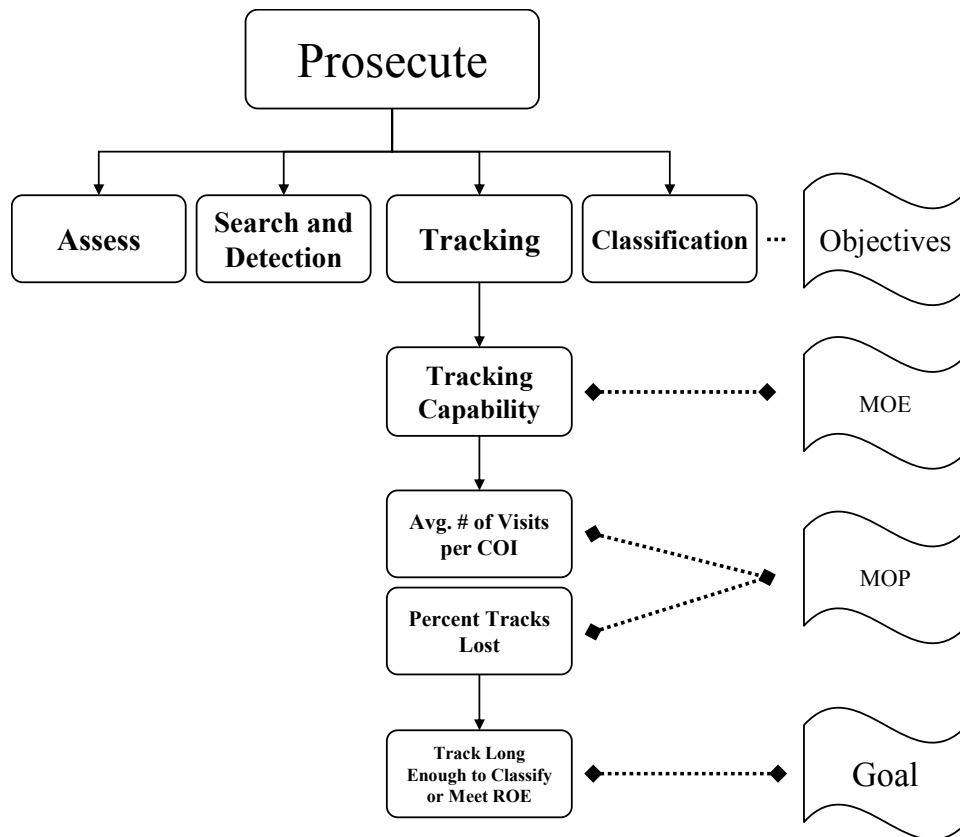
Once a threat has been identified and classified as a COI or CCOI, the threat will have to be tracked until follow-on action is needed. This follow-on action includes: (1) the sensor itself determining the threat’s bearing, range, course and speed, and communicating this data to an operational asset; (2) actions to force the threat to turn back; or (3) generate a FCS. Figure 45 represents the requirements for this subfunction.





**Figure 45: Requirements for “Tracking” Subfunction**

Thus, the objective of tracking is to track a contact long enough for ensuing actions to take place, or long enough to satisfy a combatant commander’s intent. The MOE, as represented in Figure 46, is tracking capability—the sensor’s capability to track COIs and CCOIs after they have been discovered and identified as such. Two MOPs play an important role in the tracking objective hierarchy. The first is the average number of visits per COI (by a sensor), which ensures that the sensor being tracked is the same one identified in earlier steps of the process. The second MOP is that of minimizing tracks lost. In order to meet this MOP, the sensor has to be sensitive enough to track a contact even after it takes evasive actions to avoid redetection.

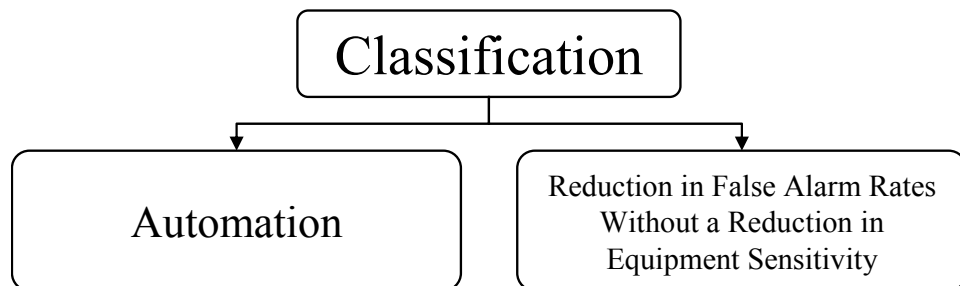


**Figure 46: Revised Objectives Hierarchy Matrix for “Tracking” Subfunction**

The goal of this subfunction’s MOE is to track a contact long enough to classify the contact (next subfunction), or long enough to meet the rules of engagement.

### 2.3.3.7 Classification

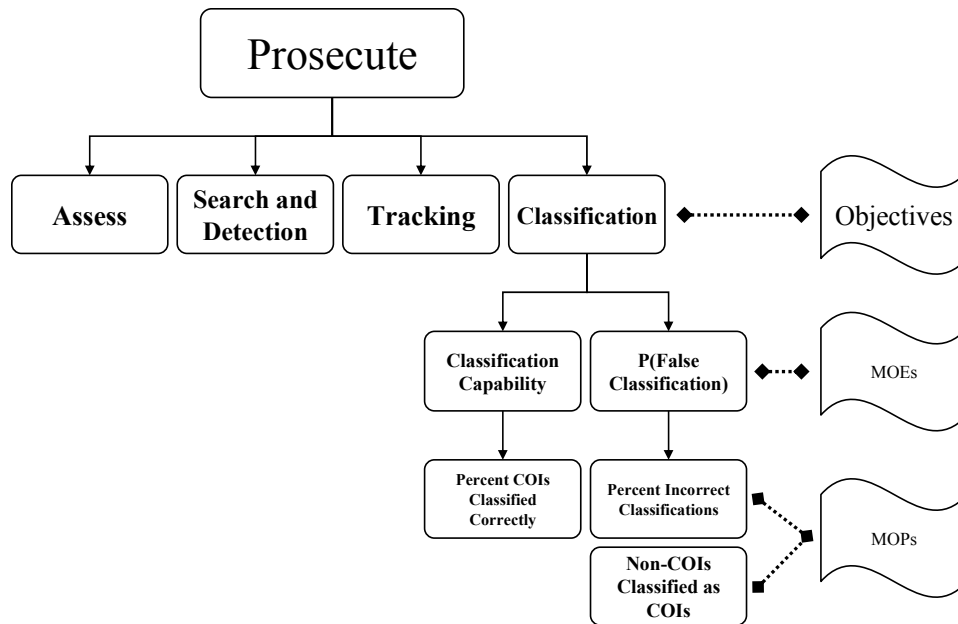
The primary requirement of “classification” is to provide a high confidence classification of COI/CCOIs using an automated process. Both of these requirements are represented in Figure 47.



**Figure 47: Requirements for “Classification” Subfunction**

When a contact is detected, it is detected because of an acoustic or nonacoustic signal. The sensor can potentially classify using a library of sound profiles from the retrieved signal, and examine matches in order to classify the contact as a submarine or UUV. The stronger the signal received (or if received via more than one asset), the higher the confidence will be that the classification is correct. Less intense signals (or less comparative via multiple sensors) reduce the classification confidence and leave room for doubt.

The objective of classification is a reduction in false alarm rates without a reduction in equipment sensitivity. MOEs include a classification capability and a probability of false classification. MOPs are as listed in Figure 48:



**Figure 48: Revised Objectives Hierarchy Matrix for “Classification” Subfunction**

The primary goal of the Objectives Hierarchy is to arrive at objectives, MOEs, MOPs, and goals that the SoS should be able to achieve. The SEDP uses the Objectives Hierarchy to generate viable alternatives that meet the goals established in the analysis and helps decide if the alternatives generated solve the effective need.

### **2.3.4 Objectives Analysis for Defeat**

As previously presented in the Functional Analysis portion of this addendum, PDT identified three subfunctions for its assigned top-level function of “defeat.” These subfunctions are maneuver, deter, and engage, and are defined below:

#### ***2.3.4.1 Maneuver***

- The ability to collaborate with friendly assets for complimentary effect while using the environment and topography for our advantage
- Without a platform capable of autonomous intelligent maneuver or sustained operations, the remaining functions could not achieve their objectives

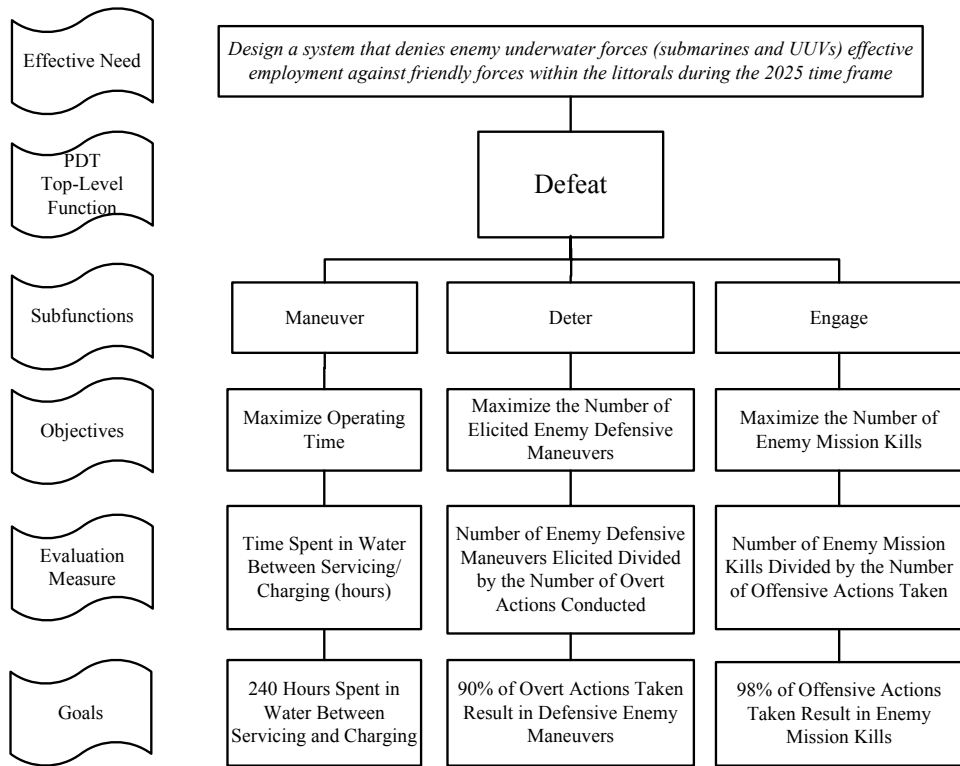
#### ***2.3.4.2 Deter***

- The ability to make a show of force or presence to dissuade enemy opposition or movement, and/or any overt actions taken to force, or control, enemy assets at a safe distance from allied forces
- Includes some soft kill methods as well as other measures taken to alert the enemy of own-force presence (i.e., making noise, pinging, etc.)

#### ***2.3.4.3 Engage***

- Neutralization or disruption of the enemy’s ability to perform their desired mission
- Includes offensive and defensive measures taken with the end goal being a soft or hard kill

Evaluation measures for each objective are established to gauge the SoS’s performance in that area. These evaluation measures represent metrics that complete the associated objective. Figure 49 is the PDT’s Objectives Hierarchy defining the objectives, evaluation measures, and goals of the “maneuver,” “deter,” and “engage” subfunctions.



**Figure 49: The PDT's Value System Hierarchy**

As previously stated in the Need Analysis, the subfunctions of deterrence and engagement were not studied further within the bounds of this project. The subfunction of maneuver was reassigned for research and study by both the Prosecution and Deployment Teams. The Prosecution Team absorbed the objective of maximizing system operating time, while the Deployment Team was given the objective of maximizing the speed at which the system gets into the OA.

### **3.0 DESIGN AND ANALYSIS**

#### **3.1 ETHICS IN ANALYSIS**

The ethics phase of the SEDP largely involves the identification and articulation issues that have the potential to mislead consumers and stakeholders based on a wide variety of topics such as false claims (particularly in the areas of safety and reliability), conflicts of interest, risk, and uncertainty. Critical to the successful implementation of any system is the stakeholder understanding of these issues so that, at the conclusion of the study, an appropriate decision can be made.

Personal bias in research and analysis on the part of the participants in a project can lead to poor assumptions and false findings. Most of the time, participants are completely unaware of the biases they harbor, and honesty in reporting is often harder to attain than one might assume, as it is human nature to embellish the results of what often becomes a long, labor-intensive, project. Participants also have the potential to become emotionally vested in their work and therefore lose objectivity. These issues can be devastating to the potential of a system if not identified and mitigated early on, and continually managed throughout the SEDP. Once identified, steps can be taken to mitigate the effects the biases have by blocking their influence on the conclusions of the study.

Systems engineers are information brokers, or the bridge between stakeholders with specific needs and component engineers with specific products. They specialize in the management of a program, not in the physical design of solutions. When systems engineers fill the role of either the stakeholder or the component engineer the result will be a loss of objectivity in analysis, confounding assumptions, and in general, an inadequate engineering design. For example, the systems engineer who designs a particular component will have a great deal of difficulty objectively weighing that component against other alternatives. It should also be noted that systems engineers generally manage component engineers from a wide variety of distinct disciplines. For example, the littoral ASW C4ISR project encompasses many engineering fields including physical sciences like oceanography, meteorology, electrical engineering, acoustical engineering, naval architecture, aeronautical and astronautical engineering, and

communications engineering, as well as social sciences in the application of tactics, doctrine, strategy, etc. It is unrealistic to assume that any one person can master all of the above subject areas in a limited amount of time.

Every avenue available to identify stakeholders from across the Navy to answer questions and provide real-world ASW C4ISR needs to this project were explored. Similarly, considerable effort was made to contact and work with many real-world subject matter experts and component engineers for proposed solutions to stated stakeholder needs.

As this project is primarily an academic study, it has been difficult to “task” engineers or stakeholders to provide the appropriate amount of information required for this analysis. While SEA-8 received a great deal of help and support from many volunteers from outside agencies and from across the NPS community, SEA-8 had to make assumptions and play the roles of both stakeholders and component engineers with unknown results.

### **3.2 SCENARIO BUILDING**

In order to establish a method of comparing and evaluating current and future ASW force structure alternatives using the SEDP process, SEA-8 developed a series of scenarios that scoped the proposed operating concept, the most challenging of which is outlined here briefly, and in more detail later in this report.

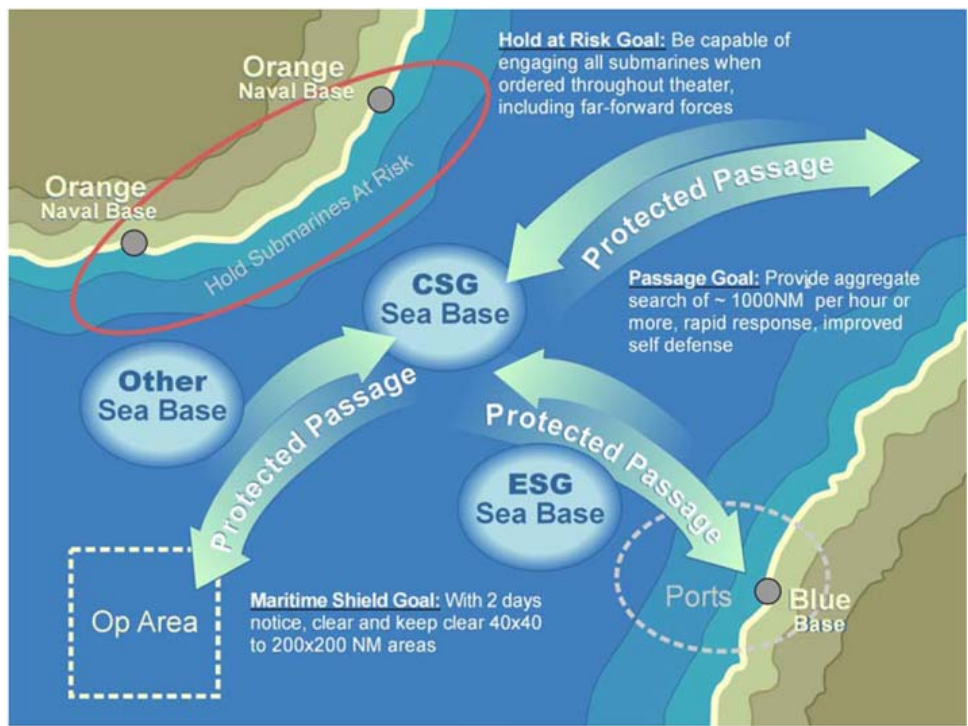
The Navy’s transformational efforts in ASW are focused on gaining maritime superiority by rapidly finding, destroying or, where necessary, avoiding enemy submarines, thus rendering the submarine irrelevant as an antiaccess weapon against US and coalition naval forces and sealift capabilities.

Figure 50 shows that the underlying Future ASW Warfighting Vision focuses on capabilities in three functional areas: the ability to form a “Protected Passage” of the SLOCs and to protect forces during transits, the maintenance of a “Maritime Shield” that would deny submarine access to operating areas and the Sea Base, and the ability to “Hold at Risk” enemy submarines throughout the maritime theater.<sup>91</sup>

---

<sup>91</sup> United States Navy, “Naval Transformational Roadmap 2003: Assured Access and Power Projection...From the Sea,” [www.chinfo.navy.mil/navpalib/transformation/trans-pg19.htm](http://www.chinfo.navy.mil/navpalib/transformation/trans-pg19.htm), (accessed 17 July 2005).

With SEA-8 academic time constraints in mind, and on the advice of many ASW experts, SEA-8 focused their attention on only the most challenging of the above listed missions—a “hold at risk” mission conducted in defense of an island nation in a confined littoral environment. Furthermore, SEA-8 used the current Office of the Secretary of Defense (OSD) “10-30-30” speed of response and time to act strategy, ensuring that US ASW forces arrive on station seizing the initiative within 10 days, obtaining the capability for a swift defeat within 30 days, while maintaining the ability to reset the force within another 30 days.



**Figure 50: Future ASW CONOPS, Office of Force Transformation**

In the selected scenario, an enemy underwater force is preparing to conduct offensive operations within a friendly island nation strait. The US is required to defend this island nation from threatening enemy undersea action and possible invasion. The President has called for the deployment of several Strike Groups into the region to form a sea base, but before they can operate effectively within the region, the enemy submarine threat must be located and neutralized. The ASWC organizes a SoS from assets in theater and detached them to the island nation strait OA in advance of the Strike Groups. Prior to the SoS’s detachment, intelligence suggests that one enemy submarine is operating in the strait while two additional enemy submarines equipped with UUVs are preparing for



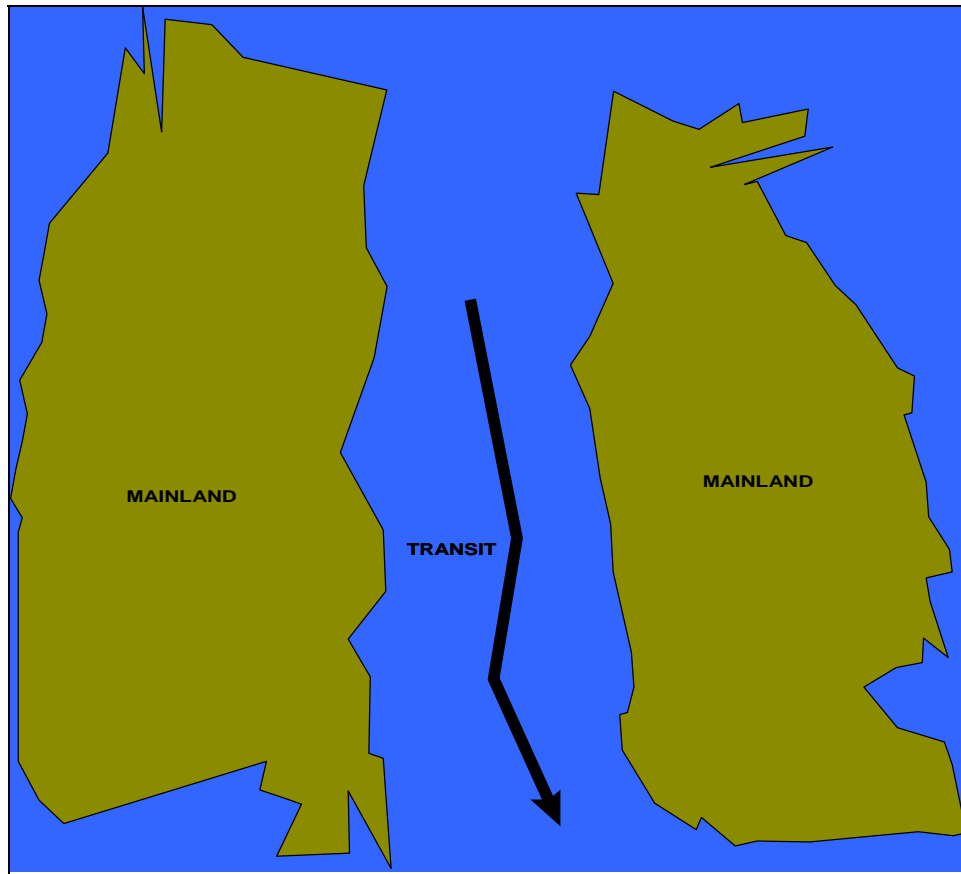
offensive patrols. Due to escalating hostilities, denial of enemy underwater force operations is deemed critical to the defense of the island nation strait. During the SoS transit to the OA, the two additional enemy submarines, previously reported in port, are located getting underway and are now suspected of patrolling the strait.

The various alternatives for littoral ASW SoS will each be evaluated in their conduct of the ASW Search and Execution mission with the task of neutralizing the enemy underwater threat. Specifically, each alternative SoS will be evaluated on their performance to begin ASW operations in the OA within 72 hours of tasking, neutralize the threat within 10 days, and sustain that level of denial for 30 days to permit follow-on Strike Group operations.

Littoral warfare will present a myriad of geographic scenarios in 2025. In an effort to classify these possibilities into a tangible and definable quantity, SEA-8 has streamlined potential operating environments into three separate scenarios: very constrained, semiconstrained, and coastal. There are cross-scenario similarities; yet, each presents unique challenges to the warfighter of today and 2025. Poor sound propagation due to the depth of water and close proximity to land must be a constant consideration. Tides and currents are a factor when operating in the littoral. The following is a list of specific considerations for each scenario.

### **3.2.1 Very Constrained Scenario**

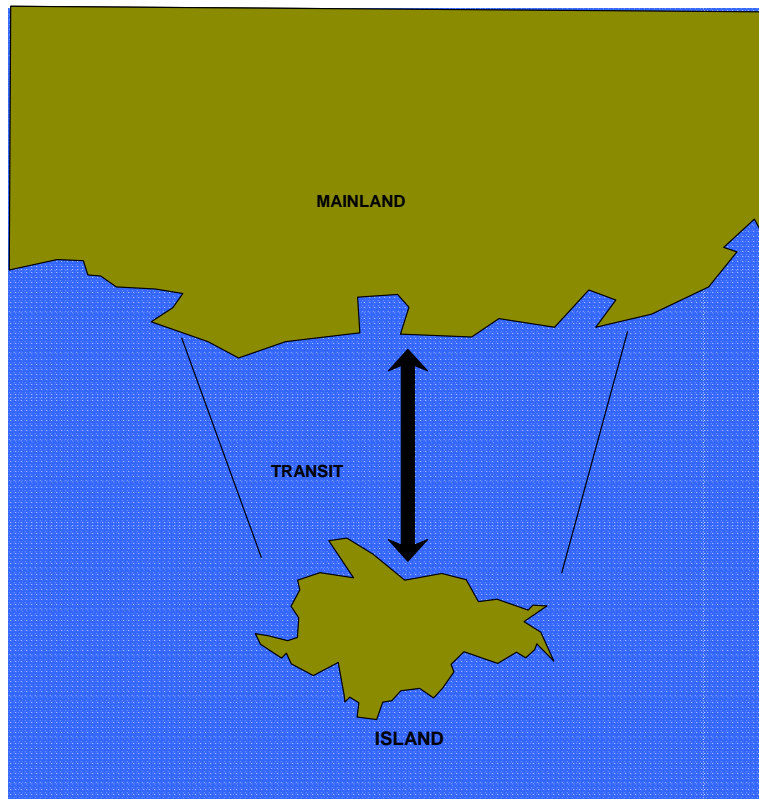
Forced joint entry operations may be required in order to provide friendly forces access to the battlespace. When addressing this scenario, SEA-8 considered the confined waters and predictable navigation routes. Confined space indicates that submarines are likely restricted to operating in specified areas based on the depth of the water. This also indicates that surface traffic is likely to follow a specific navigational route, rendering ship movement predictable, further simplifying a submarine's firing solution and limiting lines of approach. The geography of this scenario, as shown in Figure 51, limits the ability to maneuver, which is a Blue force necessity in order to bring sufficient firepower to the point of attack.



**Figure 51: Very Constrained Scenario Geography**

### **3.2.2 Semiconstrained Scenario**

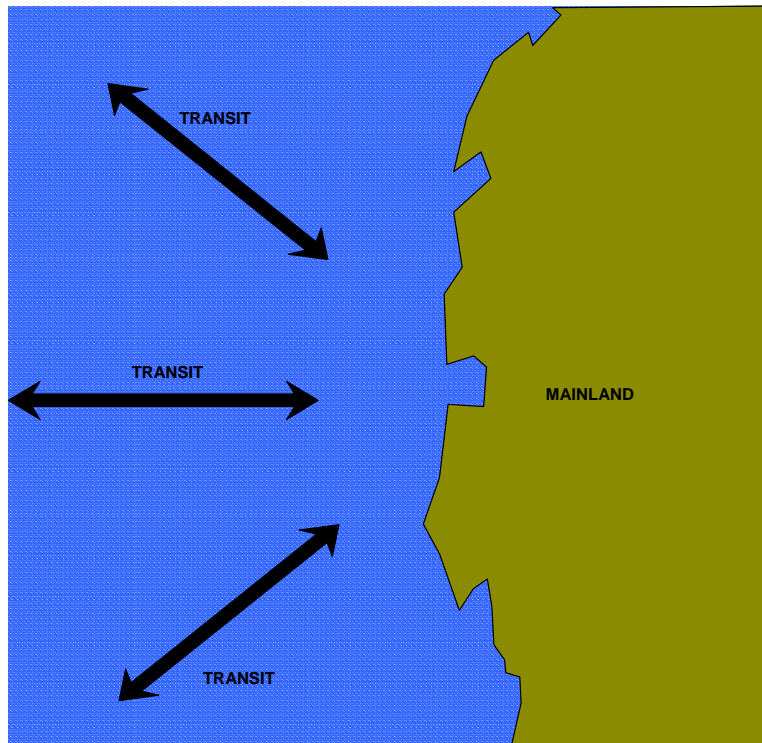
The semiconstrained scenario is represented by a strait between an island nation and a significantly larger mainland nation providing Blue forces more maneuverability than the very-constrained scenario. Factors considered are any large volume of water, limited access, relatively predictable transit/commerce routes, as well as various evasion options available to Red and Blue forces. The volume of water considered to be littoral presents a significant challenge. This scenario, based on geography, lends itself to an antiaccess/area denial strategy. The relatively short distances (100 NM) between the two bodies of land translate into a potentially high volume of commercial shipping, which complicates the ability of forces to attain a CUP due to a large amount of false contacts. The geography of this scenario allows for easy identification of transit routes. In the case of actual combat operations, Blue forces will attempt to avoid transiting these areas; however, the constraints of time, distance, and space may require Blue forces to transit the area.



**Figure 52: Semiconstrained Scenario Geography**

### **3.2.3 Coastal Scenario**

The coastal scenario illustrates a coastal topography with both open-ocean and littoral environments. The number of potential transit routes is increased, which makes it more difficult to localize potential threats. This circumstance may provide some of the most challenging factors for establishing maritime dominance in the littoral. The ability to secure friendly maneuver space will be difficult due to several different axes of attack that Red forces may utilize against Blue forces. This scenario, shown in Figure 53, is particularly useful in analyzing potential applicability to homeland defense situations.



**Figure 53: Coastal Scenario Geography**

For the purposes of SEA-8 research, the friendly ASW force will consist of a SoS—the primary unit of action in ASW planning—and be comprised of forward-deployed units as well as deployed strike group aircraft, surface ships, and submarines along with their organic sensor and weapons systems. Specific SoS composition will be discussed later in greater detail in the section covering system decomposition analysis.

While DOD places a large emphasis on Joint Operations, ASW is one of the few mission areas where the US Navy, alone, bears considerable responsibility for accomplishment of the mission. Therefore, the SEA-8 project is considerably service-centric, but does not exclude consideration of resources from other services as well as support from allied nations. The SoS will operate with joint reach back ability, integration ability, and utilize joint information and control architectures as needed and available in the driving scenarios.

### **3.2.4 Anticipated Threats**

ASW has always been characterized by the dominance of one nation's technology over another's. Traditionally, this technology-focused warfare was the sole provider of the world's superpowers. However, since the end of World War Two, with the spread of technology to all parts of the world, it has become apparent that many nations already have, or will have, the ability to field a credible submarine force. It is likely that over the next 20 years many underdeveloped nations will possess submarine forces featuring minisubmarines, improved diesel submarines with AIP technology offering extended underwater endurance, and improved stealth and advanced combat systems with considerable first-strike lethality.

The littoral environment presents a myriad of threats to ASW operations.

A submarine force composed of a few relatively unsophisticated submarines is capable of conducting coastal defense or sea denial missions. Such a force can attack merchant and logistics shipping, conduct covert offensive mining, support special operations forces, attack amphibious ships, and hold regional naval forces at risk.<sup>92</sup>

Quieter and more capable enemy submarines will continue to challenge the Navy as it attempts to ensure access in the littorals. SEA-8 identified four specific platform threats for the purposes of this study: diesel, AIP, and nuclear-powered submarines, and UUVs.

#### ***3.2.4.1 Diesel-Powered Submarines***

Although a submarine threat could come from any country that possesses at least one submarine, diesel-electric submarines are readily available and easy to acquire, creating a likely threat well into the 2025 time frame. This platform presents smaller space requirements than a nuclear submarine plant. Diesel propulsion submarines provide reduced chances of visual, heat, or magnetic counterdetection.

#### ***3.2.4.2 Nuclear-Powered Submarines***

Nuclear-powered submarines are benefited by increased range and on station time. This plant provides the most autonomy when patrolling for extended periods

---

<sup>92</sup> Littoral Anti-Submarine Warfare Concept, Naval Doctrine Command, 1 May 1998.

of time. Nuclear-powered submarines are susceptible to a high thermal-acoustic signature.

#### ***3.2.4.3 AIP Submarines***

Advances in AIP and associated technologies for use aboard submarines continue to be made at a rapid pace. Producing no exhaust heat, AIP submarines will be difficult to detect, while the fuel cell allows cruising under water for weeks without surfacing. Currently (2005), power outputs of AIP technology are on the order of 400-500 hp where a typical diesel plant is capable of producing over 3,000 hp and nuclear plant rated at over 20,000 hp. In light of this, AIP technology will be most valuable in low-speed, long-range submersibles.

#### ***3.2.4.4 UUV Technology***

UUV assets will begin to present a greater threat over the next few decades. These highly versatile vehicles are flexible for launch from a variety of platforms and are capable of operating in autonomous or controlled modes. Providing multiple capabilities in a variety of roles, these vehicles are cheaper to manufacture than manned submarines, making them extremely attractive to countries with limited military budgets. Individually, the UUV is the least capable of submersibles due to limited range and the automation capabilities it must have.

### **3.3 ALTERNATIVES GENERATION**

The Alternatives Generation portion of the SEDP was completed in two distinct steps. The first step involved detailed research by each SEA-8 team (Command, Deployment, Prosecution, and PDT) to determine which entities were capable of accomplishing each team's associated subfunctions. Specifically, each team identified future or existing systems or methods that were able to perform required functions as recognized in the Objectives Hierarchy portion of the SEDP.

The Command Team generated alternatives by decomposing the subfunctions of communicate, network, and transfer ISR data. The Deployment Team used the subfunctions of prepare, deploy, and sustain. While the Prosecution Team looked at the subfunctions of assess, search and detect, track, and classification to scope and bound

alternatives generation. The PDT leveraged their subfunctions of maneuver, deter, and engage to find effective alternatives to the ASW littoral problem of 2025. SEA-8 assessed the ability of each team's alternatives to solve the ASW problem by using five initial alternative scenarios: Tripwire, Sea Tentacle (TSSE), War of Machines, LAG, and Floating Sensors. The Floating Sensors alternative was discarded due to its assessed infeasibility in the logistical area.

In the second portion of the Alternatives Generation process, individual components from the generated team-specific lists were combined to create a SoS capable of performing the defined ASW mission. Although thousands of architectures could result from the combinations, and numerous SoS were seriously considered, only four were finally determined to be distinct, feasible, and useful for follow-on SEA-8 Modeling and Analysis.

### **3.3.1 Command Alternatives Generation**

#### ***3.3.1.1 C4ISR Design Space Analysis***

Design Space Analysis lays the framework for Alternatives Generation. It is a mental construct of an intellectual space that envelopes or incorporates all possible solutions to the C4ISR design problem. The Design Space for the Command Team started out very large with a wide range of possibilities to be considered. The team started by exploring existing solutions to the ASW problem and expanded its scope to include contingency planning that is in development. The Command Team used SEDP as the construct for Design Space Analysis. The Design Space Phase is designed to answer the following questions:

- What does the stakeholder need?
- What impediments stand in the way of achieving this need?
- What technologies are available to deal with these impediments?
- What are the external constraints (time, money...) on this system?

The Command Team used these questions to parse the SEA-8 tasking and develop a hypothesis to help bound the ASW littoral problem:

*The SEA-8 Command Team conducted analysis of future C4ISR system alternatives capable of meeting the needs of the US Navy for littoral ASW*

*in the 2025 time frame. Analysis includes research into systems that were PORs as well as SEA-8 and TSSE alternatives. This analysis identified impediments by using a reasonably expected range of future operating environments and identified future technologies designed to counter impediments in 2025.*

The Command Team used this hypothesis as a baseline to decompose the C4ISR problem. A starting point for decomposition was defining architecture alternatives.

### **3.3.1.2 C4ISR Network Architecture Alternatives**

Two distinct network architectures were considered for tactical data sharing: centralized and decentralized. This network architecture analysis identifies which architectures had the greatest effect for sharing and fusing tactical information across all nodes in the C4ISR system. The analysis determined that the most advantageous way to reduce the prosecution timeline was through rapid tactical data exchange.

**Centralized Network Architecture Alternative:** For the purposes of Alternatives Generation, the centralized network architecture was analyzed to connect all surface, air, and undersea participants in the AOR as well as reach back to strategic-level decision makers. The centralized network architecture operates as a “publish and subscribe” system, where all participants forward tactical data to a master node that combines the data and distributes a common picture for all participants. Centralized network architectures represent a system that is most similar to Internet protocol and can provide numerous advantages over current tactical data links.

**Decentralized Network Architecture Alternative:** An additional network architecture product of Alternatives Generation is the decentralized network architecture used to distribute tactical data to all participants throughout the battlespace. Decentralized network architectures are constructed to use the participants as localized processing units. The decentralized system architecture removes the need for a master processing node and thereby places the processing and fusion responsibility on the user node. Decentralizing tactical processing has many advantages and has the potential to be very beneficial to connecting a warfare system.



Using the centralized and decentralized architectures, the Command Team considered the various C4ISR components and environmental mediums the C4ISR communications system must operate within.

### ***3.3.1.3 C4ISR Communications Architecture Alternatives***

When considering the communications architecture of the littoral ASW C4ISR system, the physical environment presents challenges that add complexity to developing the communications architecture. The US Navy has had a long history of wireless communications above the surface of the water, and these “atmospheric” communications have become well known and understood. The same cannot be said for communications under the surface of the water, because it has not been fully exploited. Because of these difficulties the Command Team chose to break the physical architecture alternatives down into two distinct categories of networks: Undersea and Atmospheric.

3.3.1.3.1 SYSTEM NODE DEFINITION. Before discussing the alternatives for connecting this communications system, it was important to consider what types of sensors, weapons, and platforms were to be “connected.” As the SEA-8 Command Team found, not all nodes in this SoS were the same. Furthermore, simply classifying nodes as “weapons,” “sensors,” or “platforms” did not offer insight into what communication function that node must perform to support littoral ASW. The Command Team found it necessary to break these types of nodes into three categories that define their use and function. This breakdown included decision nodes, sensor nodes, relay nodes, and multifunctional nodes.

**Decision Node:** A decision node performs the highest level of processing required to ultimately make decisions that will change the battlespace. While it is hard to imagine a manned node that is not a decision node, decision nodes need not be limited to human platforms alone. An autonomous node that has the authority to act on its own behalf, with the ability to distinguish between friendly and enemy units, is a decision node.

**Sensor Node:** A sensor node performs a function within the ASW environment to collect information, but requires authority to engage the enemy. A

sonobuoy that collects acoustical data for other platforms to process is an example of a sensor node.

**Relay Node:** A relay node is any node in the system that has the ability to serve as an information broker for other nodes. A communications satellite is an example of a relay node in that it collects information from one node and distributes it to another.

**Multifunctional Nodes:** In many cases, specific platforms, sensors, and weapons can serve as more than one, if not all, nodal functions. One can easily imagine a ship or aircraft collecting data from off-board sensors, fusing collected data with own-ship sensors, relaying that data to other units, and then deciding to take action to engage the enemy. In this example, the unit performs the functions of all three nodes. In a truly distributed network, information would be shared equally by all nodes, in essence, making all nodes perform all functions. In practice, this is not feasible since the “thinking field” is limited by cost and physical ability. In fact, such a network of completely equal nodes would most likely saturate the finite electromagnetic spectrum and may serve to defeat itself with information overload.

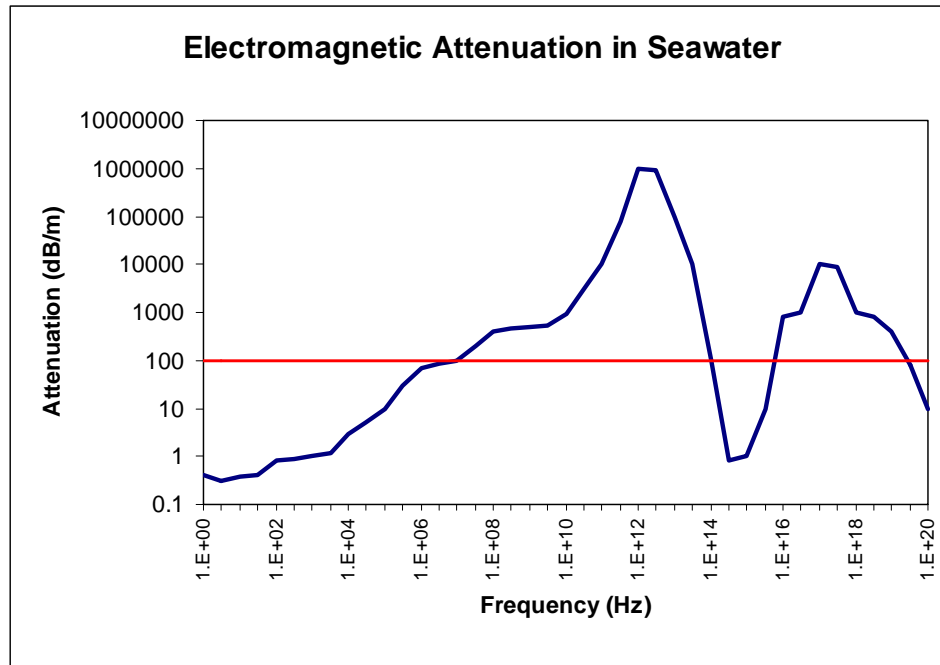
Within the structure of this analysis the Sensors Team conducted analysis and development of various sensor nodes and the Command Team worked to meet the information system requirements. Decision nodes were discussed as part of the overall analysis of alternatives with respect to the modeled scenarios and were outside the design scope of the Command Team. The remainder of this chapter is dedicated to focusing on the functions and alternatives of communications propagation and relay node alternatives in an effort to inform stakeholders of the pros and cons associated with each system.

#### 3.3.1.3.2 UNDERSEA COMMUNICATIONS ALTERNATIVES.

The future of ASW resides in a distributed network of platforms, sensors, and weapons that can communicate at a significant distance undersea. Such a system would enjoy stealth, agility, and the ability to conduct complex operations at speed and depth. The problem, however, lies in the basic application of physics and an understanding of the complex undersea environment. To overcome the complex undersea environment, new

technology and procedures need to be developed to communicate at tactically significant ranges and data rates.

**The Undersea Environment:** As with any method of communicating at distance, attenuation is the limiting factor. Considering the whole EM spectrum, attenuation in seawater is not greatly different from that of pure water, with the exception of particulate matter suspended in the medium. Silt, plankton, and air bubbles conspire to absorb and scatter radiation. The closer to the shoreline, the higher the presence of particulate matter and more pronounced the absorption and scattering. Figure 54 shows a simple plot of the attenuation of EM radiation in seawater where attenuation is plotted on the “y” axis in decibels per meter, and the “x” axis is plotted in frequency in Hertz (Hz). The figure shows three distinct regions where attenuation is relatively low, near one decibel per meter or better. These areas offer the best frequency ranges for undersea communications. The drop off at the far right side of the chart near  $1 \times 10^{20}$  Hz constitutes those frequencies in the range of Gamma Radiation. The area located near  $5 \times 10^{15}$  Hz constitutes that range at 500 nanometers. The final promising region resides on the right side of the chart below 1,000 Hz in the Extremely Low Frequency (ELF) range. Each region demonstrates some hope for undersea communications and was explored in an analysis of alternatives.



**Figure 54: EM Attenuation in Seawater (Professor Robert Harney)**

**Undersea Gamma Radiation Alternative:** The decline in attenuation at the far right-hand side of Figure 54 makes it clear that gamma radiation travels through seawater with relatively little attenuation, on the order of 10 decibels per meter. While the attenuation may be acceptable for communications at ranges undersea, there are many other problems associated with the practical application of using these frequencies. At present, only large particle accelerators are capable of producing such radiation. Even if a gamma radiation-based communications system were viable for military application in the future, political and environmental concerns would most likely limit its use, as this system would potentially expose hazardous radiation into the oceans. After consideration, this alternative was not a viable option for undersea ASW communications, barring a major breakthrough in technology and understanding of human physics.

**Undersea Blue-Green Light Alternative:** In Figure 54 there is a clear window of low attenuation near  $5 \times 10^{15}$  Hz. The benefit of using blue-green lasers to penetrate water has been known for some time, and there are a handful of militarily significant applications to this technology. Two-way communications is a much more complicated problem than simple detection and development of two-way laser

communications for undersea applications. Complications that limit the use of blue-green lasers in seawater stem from particulate absorption and scattering of the light. These complications increase as the laser system gets closer to the littorals and the particulate matter increases dramatically. Undersea Laser Modems can communicate at ranges of up to several miles in ideal conditions, in clear waters associated with the deep sea, but performance drops off drastically with ocean conditions. Additional problems must be solved in beam acquisition. Laser modem receivers need to detect and acquire the laser signal. This requires a robust physical control system to ensure that the receiver maintains a lock on the transmitted signal as the platform drifts in the environment. While the data rate for a laser modem is much higher than other methods of undersea communication, controllability and range, based on the environment, limits the practical application of a laser-based system in the littorals.

**Undersea Tele-Sonar Alternative:** The final and most promising portion of the electromagnetic spectrum for littoral communications is found below 1,000 Hz in the ELF range. The military has exploited this region for years in the use of sonar. Frequencies of less than 1,000 Hz can be used at great ranges, but suffer from low data rates. The relationship between data rate and frequency is directly proportional—the lower the frequency, the lower the data rate. While a Tele-Sonar Modem may be able to communicate at tens, if not hundreds, of miles, the rate of data exchange would be very slow. Obviously, extensive tradeoff analysis is required to find an ideal range of frequencies and data rates, but as far as undersea communications at tactically significant undersea distances, Tele-Sonar offers the greatest promise for the future.

## **UNDERSEA RELAY NODE ALTERNATIVES**

**Connected Relay Nodes:** The immediate benefit of any connected relay system is its inherent stability and its dedication as a communication channel. For example, any undersea sensor network that can be connected via fiber-optic, coaxial cable, or copper wire line will enjoy a dedicated path to the rest of the network via an intermediate shore station. The only environmental concern is line attenuation and booster stations placed along the path of the line serving to amplify the transmitted signal. Data rates with these methods are all very high, with fiber-optic line exceeding 1 GHz of bandwidth per

second. However, there are several serious drawbacks to this method of relay in a combat environment.

Unless the system is already in place, these lines take time to deploy and service, and any cable laying ship would be an easy target in a hostile environment. The US Navy considered plans to lay cable using autonomous undersea vehicles, but their payload is limited relative to a cable-laying ship. Precise control of the UUV is a complicated matter without a rudimentary undersea communications system in place. This situation is further complicated by the fact that technology is readily available to detect submarine cables and disabling all communications is a matter of simply cutting the line.

For the purposes of SEA-8's project, it was unlikely that an extensive submarine cable network was a viable option, because such a system is not available at the start of the crisis. Development of such a system was unlikely given the timelines for the SEA-8 crisis.

**Undersea Vehicle Relay Node:** Many have proposed a communications network infrastructure based on a system of UUVs and/or submarines serving as relays much like a high altitude aircraft. While theoretically this alternative may seem promising, practical application of this alternative is doubtful. UUVs or submarines are limited to the same connectivity performance problems as other underwater communication nodes. At a nominal 2 NM to 5 NM communications range, it would likely take tens, if not thousands, of dedicated UUVs to connect this system acoustically. A blue-green laser system would likely offer similar ranges, depending on water clarity, but aiming the sensitive optical antenna would be a continual complication as the vehicle traveled through the undersea medium. For these reasons, an underwater vehicle, UUV or submarine would not make a viable communications node. There is one notable exception to this assumption.

If a UUV or submarine were conducting missions, other than acting solely as a communications relay, within the medium using the principles of network-centric warfare, it would benefit all of the surrounding nodes to maintain a common operating picture (COP). There is little benefit to creating a dedicated communications UUV unless it can share its information with other nodes in the system.

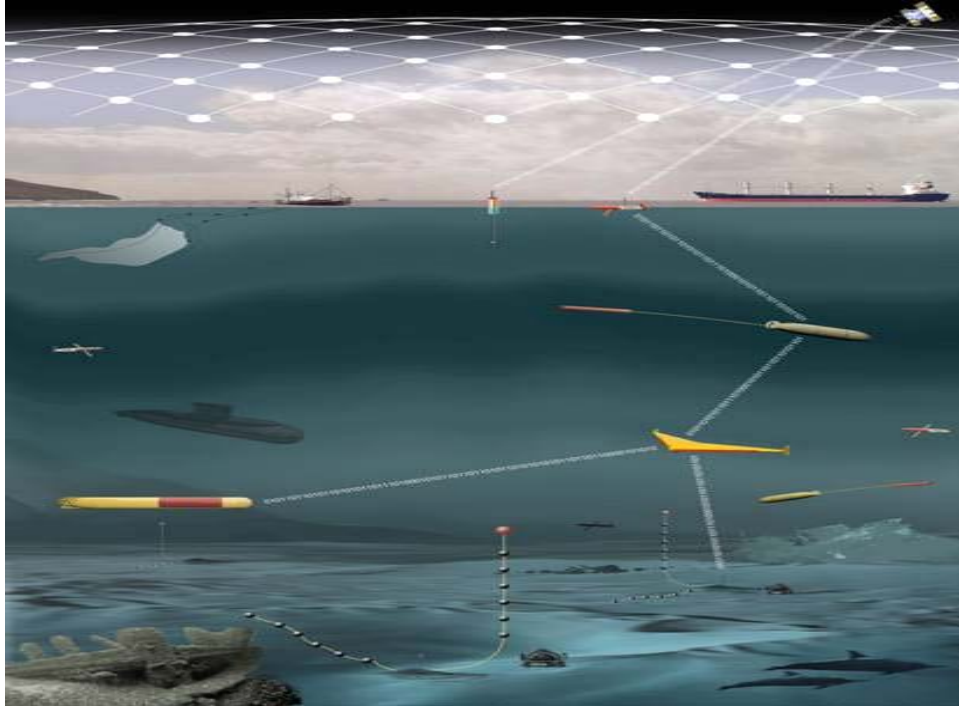
**Gateway Node:** A specific relay node of particular importance to the architecture of this ASW C4ISR system is called a gateway node. Because of the distinct differences found in the comparison of the undersea and atmospheric environments, the inability to find a common medium that works equally well in both, it has become necessary to locate an intermediary solution between these two architectures. The gateway node connects the undersea architecture with the atmospheric architecture, linking the whole ASW C4ISR SoS into one overarching architecture.

**Gateway Buoy:** Free-floating or tethered, a gateway buoy serves to convert the acoustic energy used by the undersea Tele-Sonar modems into RF energy for use by atmospheric systems such as ships and aircraft. The main difference between this system alternative and the sea-floor gateway is that the primary function of this system is to convert data between RF and acoustic energy at sea.

**Sea-Floor Gateway:** The stations are embedded, resting, or connected via the sea floor with physical connections into the architecture via an undersea cable system. Unlike the gateway buoy, this system collects acoustic information via an undersea modem and relays it to shore stations via a connected line, usually via coaxial cable, copper wire, or fiber optical line.

#### 3.3.1.3.3 ATMOSPHERIC COMMUNICATIONS

ALTERNATIVES. The US Navy's future vision for ASW calls for the creation of a "thinking field" of distributed platforms, sensors, and weapons connected through a robust, secure, self-synchronizing network—an "Internet at sea." To bring this vision to reality, network engineers must build an information system architecture based on the principles of network-centric warfare, with nodes sharing data both above and below the surface of the water over significant ranges. Figure 55 represents an artist's conception of this vision.



**Figure 55: Artist Rendition of an Undersea Network (University of Washington, Applied Physics Laboratory)**

With the goal of extending the reach of friendly sensors and weapons into enemy waters and keeping friendly personnel out of harms way, the vision relies on an extensive array of unmanned and autonomous platforms, all connected via wired and/or wireless links. With so many “netted” sensors, platforms, and weapons, a serious dedication to the resource management of the electromagnetic spectrum and an extensively redundant array of information exchange nodes will be required to bring this vision to reality.

The following is an analysis of alternatives for connecting the “above water” nodes (sensors, weapons, and platforms) in this ASW SoS.

**The Atmospheric Environment:** Communications at tactically significant ranges undersea is difficult even under ideal environmental and design circumstances. The trade-off between range and data rate is based on the principle that the higher the frequency the higher the data rate. The problem with using a higher frequency is the short distances that high frequencies travel. The lower the frequency, the lower the data rate, but the frequency can travel at a longer distances. Critics of this generalization will be quick to point out that the US Navy’s submarine force has relied on



Very Low Frequency (VLF) and ELF signals for strategic deterrence communications over the last several decades.

It should be understood that VLF and ELF signals travel great distances undersea, but the messages they carry are very small—in most cases less than 100 characters of data. This type of communications path is similar to flashing light, semaphore, or signal hoist, where the data conveyed lends itself to coded text for predetermined tasking where data latency is not a primary concern. At a carrier frequency of 100 Hz, for example, it may take a minute or more to transmit a 100-byte message. Even then, these frequencies require tremendous amounts of power and huge antenna arrays to transmit their messages. Submarines are “receive only” in this part of the spectrum and the earthbound antenna arrays are on the order of “miles” long. It is highly unlikely that any undersea wireless network will be robust enough to link all the nodes in a large system at the same data rates and ranges achievable in an equivalent above water architecture. A simple extrapolation of Moore’s Law has been commonly used to assume away technological problems with today’s technology. Moore’s Law is not applicable, based on the physics involved and the limits of imaginable technology proceeding along an evolutionary path, unless there is an evolution in the understanding of physics. It is, however, possible to communicate at low data rates over relatively short ranges undersea with low frequency (less than 1 KHz). These alternatives will be explored in depth in Section 3.3.1.4.3 covering undersea communications. The alternatives for such links rely on two basic alternatives: connected relay nodes and wireless relay nodes, which will be the focus of the next section of analysis.

## **WIRELESS PROPAGATION ALTERNATIVES**

Before any analysis of wireless alternatives can be explored it is first necessary to understand a few of the basic principles of radio wave propagation. Unlike fiber-optical line, coaxial cable, or telephone wires, whose well-defined characteristics do not change appreciably with time or the environment, radio propagation is widely variable depending on several environmental factors. With many variables, it is difficult to predict the performance of radio communication systems with a high degree of accuracy. As a result, most Naval systems rely on a multitude of wireless options to ensure connectivity.

Most Naval systems still require a relatively large proportion of internal space to be dedicated to communications equipment even though advances in technology have greatly reduced the size and weight of electronic components. While this isn't a tremendously difficult issue for large platforms like warships, size and weight are of significant concern to aircraft and small unmanned platforms. It is therefore necessary to consider all options available and conduct an extensive analysis of alternatives for a wide range of wireless communications.

In the case of radio frequency propagation, three primary paths exist for information to travel based on the carrier frequency selected: ground wave, sky wave, and space wave propagation paths. Figure 56 illustrates the EM spectrum and associated frequencies in Hertz. Ground waves are frequencies below 300 Hz, sky waves are frequencies between 3 MHz and 30 MHz, and space waves are frequencies above 30 MHz.

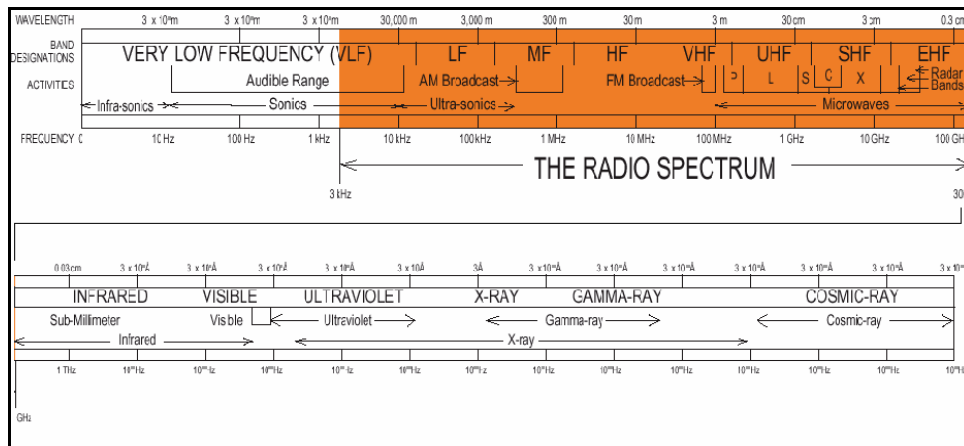


Figure 56: The EM Spectrum (US Department of Commerce)

**Ground Wave Propagation:** At low frequencies, below 300 KHz (Medium Frequencies (MF), Low Frequency (LF), Very Low Frequency (VLF), and ELF), over-the-horizon communications are via the surface wave; the majority of the radiated energy travels parallel to the surface of the earth. There are three primary factors that limit the propagation of ground waves: free space loss, diffraction, and ground absorption. Of these three, ground absorption has the most impact on limiting range, especially over dry ground. Seawater, however, is a relatively good conductor and its nominal communication ranges are often more than 1,000 NM. Long-range LF transmitters tend to radiate at high power settings to achieve such range, typically

between 1 KW and 1 MW, in order to provide adequate signal-to-noise ratio against the high level of atmospheric noise that prevail at these frequencies. While these frequencies have benefits in range, the relatively large amount of power required to transmit a signal limits their application to small unmanned vehicles or autonomous sensors that will make up the “thinking field.” As stated before, frequency and data rate are directly related and these frequencies do not lend themselves to anything other than very low bandwidth transmissions, which limit the value of low frequency signals in above-water communications.

**Sky Wave Propagation:** High Frequency (HF) signals, from 3 MHz to 30 MHz are used for medium- and long-range communications and achieve their range by skipping between the surface of the earth and the upper ionosphere. Trapped like a ping-pong ball bouncing between two plates, HF radio range depends greatly on surface absorption and the current state of the ionosphere. As stated above, seawater is a relatively stable conductor and most of the volatility in HF communications rest in the reflectivity of the upper atmosphere. The thickness of the ionosphere varies with time of day, appearance of sunspots, seasons, and geographic location, making range predictions difficult. HF communications require less power than low frequency communications and enjoy higher data rates, making this portion of the spectrum more attractive for above-water communications, but the high variances associated with environmental conditions make these frequencies less attractive than the more reliable space wave frequencies.

**Space Wave Propagation:** Frequencies above 30 MHz (Very High Frequency (VHF), Ultra High Frequency (UHF), Super High Frequency (SHF), and Extremely High Frequency (EHF)) are not normally reflected by the ionosphere and travel through the upper atmosphere out into space. These frequencies are often used for satellite communications and short-range point-to-point communications. Waves traveling along the surface of the earth are severely attenuated due to ground loss at these frequencies and therefore require antennas located above ground and within sight of one another, often referred to as LOS communications. As these frequencies continue to increase in Hertz, so does the data rate.

Unfortunately, LOS range cannot be guaranteed at distances beyond the visible horizon. VHF communications, located at the lower end of the space wave portion of the spectrum displayed in Figure 56, occasionally travel to ranges of up to 30 NM. VHF is dependent on atmospheric conditions at the time of broadcast and most often transmit from 12 NM to 15 NM, depending on antenna height and power.

As a rule of thumb, LOS communications require the transmitting and receiving antennas to be within a straight LOS of each other. Frequencies at the lower VHF range extend beyond the visible horizon, but for higher frequencies this model is sufficient. Antenna height of eye, called dip, then becomes a critical component of LOS communications, as the higher the antenna, the greater the field of view and the greater the range.

*The formula  $d = 3.75 * \sqrt{Kh}$  represents this relationship where  $d$  is distance,  $K$  is the refraction rule of thumb (4/3) and  $h$  is the antenna height.*

**Equation 1: Refraction Rule of Thumb**

Figure 57 depicts the maximum theoretical range of a sonobuoy with a one-meter high antenna, and a destroyer with a 57-meter high antenna, communicating between various nodes using LOS communications. This represents the maximum theoretical distance and assumes other losses are nonexistent. The maximum communications range between sonobuoys is less than 5 NM, based on antenna height and the curvature of the earth. This means that space wave propagation is an attractive alternative with respect to power and data rate as long as the transmitting and receiving antennas are within sight of one another.

	Sensors		Ships				Aircraft				LTA
Platform	Sonobuoy	USV	SSN (Surf)	DDG/DDX	CV/LPD	1 K'	5 K'	10 K'	50 K'	120 K'	
Dip (m)	1	3	4	57	66	333	1666	3333	16666	40000	
Sonobuoy (1m)	4.7	6.4	7.0	20.0	21.3	45.0	97.8	137.3	304.2	470.0	
DDG (57m)	20.0	21.7	22.3	35.3	36.6	60.3	113.1	152.6	319.5	485.3	

**Figure 57: Theoretical LOS Distance based on Antenna Height (Dip)**

**ATMOSPHERIC RELAY NODE ALTERNATIVES**

As previously stated, a relay node is any node in a network that performs the function of joining two or more other nodes. A communications satellite is a prime example of a relay node where information is collected by a sensor node, relayed through

the satellite to decision nodes located outside the direct communications range of the originating sensors node. For the purpose of this analysis, two types of relay nodes were investigated: connected nodes and wireless nodes. Within each of these two alternatives there are subcategories relating to the manner in which each node exchanges information. Propagation medium is the primary difference between these systems. For example, a connected system would have various benefits and limitations associated with the selection of fiber-optical cable as opposed to coaxial cable. The following is an analysis of various options for connected and wireless relay systems.

**Wireless Relay Nodes:** Due to the limitations of undersea communications and the relative difficulties associated with rapid employment of a connected (wired) communications system, one promising alternative is a system where undersea sensors breach the sea surface to take advantage of atmospheric radio propagation characteristics. There are many alternatives for atmospheric relay nodes, each with distinct advantages and disadvantages. It is important to note that any robust system will take advantage of many alternatives to ensure redundancy and delivery of information to all nodes. The following is an analysis of RF wireless systems.

Frequencies above 30 MHz offer the best mix of high data rates with relatively low power requirements. Because of these characteristics, the SEA-8 Command Team felt this alternative offered the most promise for above-water, wireless communications. The largest drawback to this alternative was the relatively short range of LOS signals and the need for an intermediate relay node to extend communications over the horizon.

**Surface Relay Nodes:** Direct LOS communications are desirable for other reasons as well. Direct LOS communications, especially with SHF and EHF frequencies, are highly directional and therefore protect information from being intercepted and exploited by enemy electronic warfare (EW) detection systems. The short distance also offers the least amount of delay in message reception, important for time-critical communications. As Figure 57 shows, it can be assumed that the maximum LOS point-to-point range is approximately 12 NM to 15 NM for ships and significantly less for antennas lower to the water.

**Aircraft Relay Nodes:** Aircraft have a significant advantage in increasing the range of LOS systems by providing an over-the-horizon option for extended range

operations. These aircraft, manned or unmanned, essentially establish cruising altitude as their antenna height of eye—the higher the altitude, the greater the field of view. Figure 57 illustrates the significant gain in range for various altitudes compared to surface-based antennas.

While aircraft greatly enhance LOS communications, the coordination of coverage presents unique operational and logistical support issues as compared to other alternatives. For example, manned aircraft would likely be a poor choice for a relay node assuming air superiority is not attained over the battlespace. Due to the rising cost and sophistication of UAVs, it is a poor assumption to assume that unmanned aircraft are “expendable” and would be an acceptable loss. Aircraft used as relay nodes would also need to be serviced logistically from a sea or shore base for repair, maintenance, and resupply. For sea-based systems where space is limited, manned aircraft and UAVs dedicated solely to communications missions take up valuable deck space that cannot be used for tactical aircraft. These factors complicate operations and make communications relay aircraft a less desirable option.

One possible advantage tactical aircraft may possess is in spare bandwidth allocation. As stated above, it may be impractical to maintain a fleet of “relay only” UAVs or manned aircraft, but if tactical aircraft were already in the area performing their intended missions there would be considerable advantage in their ability to act as a communications relay provided they had bandwidth to spare.

Therefore, it can be said that “Relay Only” UAVs or manned aircraft are not a viable alternative when compared with other options, but that every effort should be made to increase the capability of all aircraft in theater as collateral communications links when feasible.

**Satellite Relay Nodes:** Satellites offer tremendous advantage to communication systems by increasing the effective range. It is hard to imagine any fleet or military operations without major space-systems support from communications satellites. They offer high data rates at relatively low power and offer little disadvantage when compared to the logistics and operational considerations of aircraft alternatives. LEO communications satellites like iridium offer data rates sufficient for two-way communications and many other military information exchange functions at very low

power and costs. Geostationary communications satellites, both government owned and commercial, offer a wide variety of communications options that make satellite communications the preferred “long distance” alternative for military commanders in 2025.

There are some drawbacks to this alternative, mainly dealing with the dedication of communications. Satellites are “national” assets and are not organically directed. Satellite resources, military and commercial, will most likely be tasked to the limit of their capacity and not everyone will get the dedicated level of communications required. The fleet commanders, having an input, but not a final say in satellite bandwidth allocation, would be required to share with other commanders. This may or may not have a dramatic impact on the effectiveness of littoral ASW, resulting in none of the above alternatives being ruled out.

**Persistent High Altitude Relay Nodes:** A promising alternative is the use of Lighter Than Air Vehicles (LTAV). Once used extensively by the US Navy, LTVAs have again returned as an option for C2, although most proposals now call for an unmanned variety. DARPA and the US Air Force (USAF) recently completed an initial assessment of high altitude blimps and concluded that there was military utility for the use of various blimps, balloons, and other lighter than air (LTA) drones, between 65,000 feet and 350,000 feet. This option is a hybrid between UAVs and communications satellites, where many of the logistical and maintenance issues associated with UAVs are solved by the simple design of a large, controllable balloon deployed to altitudes in excess of 350,000 feet. At this altitude, the LTAV enjoys the height of eye similar to a LEO satellite, but with dynamic positioning provided by a large fan giving it the location stability of a dedicated geostationary satellite. LTAV proposals call for large solar power arrays or even small nuclear generators similar to those found on Russian sea buoys that provide enough power for robust communications months at a time. Unlike a satellite, the LTAV acts as a dedicated communications relay controlled organically by the force commander. The payload option is modular and can be configured for specific operations, launched and recovered (if necessary) by virtually any ship in the fleet capable of carrying a certain volume of helium. As the balloon is virtually invisible to radar the enemy would have a very hard time engaging the LTAV once at altitude. Even

under the most critical circumstance where enemy forces have launched high altitude nuclear airburst weapons to create an EM Pulse (EMP) disabling all satellite communications, commanders would have the option of sending up another LTAV not damaged by the attack.

Clearly this option has potential for the future of Naval C2 and was considered as an alternative for communications relays in SEA-8's SoS analysis.

#### ***3.3.1.4 C4ISR Feasibility Screening***

Feasibility screening consists of the process of removing all the clearly infeasible alternatives from future consideration in an effort to reduce valuable time and effort in the Modeling Phase of the SEDP. Those alternatives that clearly failed to meet the requirements of the littoral C4ISR ASW system were removed from further consideration. The result of this process was a list of alternatives that were feasible through modeling and analysis. This list was later improved on, reducing the number of alternatives to only the most appropriate ones considered to be relevant to the stakeholders during the Modeling and Analysis Phase.

It is appropriate to note that most of the systems and alternatives investigated by the Command Team were feasible. Each had an appropriate place and was considered valuable under certain circumstances. However, not every alternative investigated was appropriate for littoral ASW in the 2025 time frame as required in the SEA-8 campaign scenario. The Command Team used the SEA-8 Defense of an Island Nation scenario as a frame of reference to determine feasibility for this particular study, but made every effort to identify valuable system characteristics in each alternative that may be useful in other littoral or deep-sea ASW C4ISR systems.

3.3.1.4.1 C4ISR FEASIBILITY CRITERIA. Feasibility screening includes the portion of the study designed to identify criteria that can be used to screen alternatives in an effort to eliminate those alternatives that cannot meet the minimum requirements. Alternatives were disqualified by some other means outside the scope of the stakeholders needs, wants, and desires.<sup>93</sup>

---

<sup>93</sup> Andrew Sage and James Armstrong, Introduction to Systems Engineering, 2000, Wiley-Interscience Publication, New York, p. 170.



Alternatives were graded on a pass/fail basis, meaning if they were judged to be reasonably “feasible” by the year 2025 (pass), they were assigned the color green within the feasibility matrix (see Figure 60). Alternatives found to be “infeasible” (fail) received a red color within the matrix. The basis for these determinations was heavily linked with the futures analysis conducted by the Command Team. The following section covers the criteria identified by the Command Team as important criteria for the screening of littoral ASW C4ISR systems in 2025.

**Technological Feasibility:** A passing grade in this column indicates that the current pace of technology yields a reasonable expectation of feasibility with respect to this alternative. A failing grade means that, while the alternative may be theoretically possible, technology will most likely not be available before 2025 to ensure system availability.

**Physical/Environmental Feasibility:** A passing grade in this column indicates that this alternative has a reasonable expectation of performing successfully in the intended environment. A failing grade means it is unlikely that this system will operate in its intended environment.

**Operational Feasibility:** A passing grade in this column indicates that this alternative meets the basic operational feasibility requirements for availability, reliability, maintainability, interoperability, compatibility, supportability, transportability, deployability, and survivability. This is not, however, an endorsement of a particular alternatives’ compliance with specific legal or regulatory compliance in each of the above areas, rather it is a simple acknowledgement that it is feasible that the alternative will meet those requirements if fielded in a future procurement program. A failing grade means that it is unlikely that an alternative will meet one or more of the above feasibility requirements. Any alternative ultimately selected by the stakeholder will have to meet the specific requirements of each of the above areas during the Test and Evaluation Phase prior to the full-scale Production Phase of the SEDP.

**Social/Legal Feasibility:** A passing grade in this column indicates that the alternatives application in its intended use is considered to be legally and socially acceptable in the 2025 time frame. An alternative need not be considered legal or socially acceptable at the time of this study as law, regulations, and social values change with

time and circumstances. A failing grade means it is highly unlikely that this alternative will ever be used for its intended purpose due to its impact on societal or moral values. This may not preclude the development of a system, especially when considering alternatives for use as a last resort; therefore, a failing grade in this column only serves to highlight potential limitations for system use.

**Fiscal Feasibility:** A passing grade in this column indicates it is reasonable to assume the cost associated with bringing this alternative to reality is achievable. Any alternative that is selected to move forward will undergo specific cost estimation analysis during a later phase of the SEDP. A failing grade in this column means the initial research indicates the cost associated with this alternative exceeds the potential benefits of its implementation.

**Overall Grade:** In order for an alternative to be forwarded for consideration under the Modeling and Analysis Phase of the SEDP it must pass all of the prerequisite tests of feasibility screening. Only those alternatives with all green in the feasibility matrix will be forwarded for consideration.

To be determined (TBD) indicates that time was not sufficient to associate a value within a particular column. This grade was only allowed in the case of alternatives that had already failed feasibility screening and, therefore, were assessed to not be contenders for future consideration.

3.3.1.4.2 C4ISR NETWORK ARCHITECTURE  
FEASIBILITY CONCLUSIONS. **Decentralized Network Architecture Conclusion:** The largest difference between the two architectures is where tactical processing and control occurs. In a decentralized tactical data distribution system, participants take on the responsibility of fusing a localized operating picture from other participant's tactical data and operational picture input. The decentralized architecture's largest advantage is that it is rapidly configurable and composable. Additionally, the amount of information transferred between participants is relatively standardized and can easily be controlled through increasing or decreasing the distribution system's processing ability.

Consequently, there are several disadvantages that exist for decentralized network architectures. One major disadvantage of decentralized architectures is that the distribution systems required are typically not configured with

respect to open architecture. Decentralized distribution systems require identical computing, control, and processing systems to properly share information between nodes. Identical operating systems equate to rapid dissemination of appropriate software and operating system upgrades. Upgrades are required to be tested, installed, and run in conjunction with all other upgraded decentralized participants to ensure proper network operation.

**Centralized Network Architecture Conclusion:** In contrast, a centralized architecture involves shifting tactical picture processing to a central distribution system, unit, or node. A centralized architecture can be best characterized as a spoke and hub configuration where all participating nodes rely on the central node for tactical support. In a centralized architecture, participants provide their local tactical data through the network to the centralized distribution system that combines participant data and fuses the data into a COP. Fusing the COP within the central node is the most significant difference between the architectures. Shifting the data fusion to a central location enables multiple participants to generate unit-specific tactical data. Within a centralized architecture, limited bandwidth-capable units are able to contribute small amounts of information to the overall picture without carrying the burden of processing massive amounts of information to fuse their localized operating picture. COPs are sent from the central node to all participants continuously.

The greatest advantage of utilizing a centralized architecture is that the amount of data sent to the central node can be tailored to a node's limited capability and capacity. Participants of a centralized architecture do not have to utilize the same operating systems as long as the system language that is used is compatible with the central node's system.

A disadvantage of the centralized architecture is the large amount of capacity required for a COP update. COP updates have the potential to exceed many limited bandwidth systems such as unmanned vehicles that may act as relays or undersea manned systems. Overcoming the data latency associated with excessive amounts of data can be achieved through increasing processing power on each node to interpret small amounts of tactical data that results in updating the nodes' specific reporting picture.

**Network Architecture Conclusion:** The tactical data architecture feasibility analysis clearly indicated that a centralized architecture provides the most potential for use within future warfare networks. For the purpose of this project, centralized tactical data network architectures were applied to each of the overall project alternatives for modeling and further analysis.

3.3.1.4.3 C4ISR UNDERSEA COMMUNICATIONS FEASIBILITY CONCLUSIONS. After basic analysis, it was clear that gamma radiation was not an option for undersea communications even though it has relatively good attenuation properties in seawater. The blue-green portion of the visible light spectrum is much better, but does not lend itself to littoral operations, where particulate matter greatly degrades communications ranges. While a blue-green laser modem option may work in some cases at ranges greater than 5 nautical miles, it will not work for those ranges with any reasonable certainty in this littoral ASW problem. It may work as an option for communications on the order of hundreds of yards. Clearly the best alternative for littoral ASW is a Tele-Sonar modem operating at the ELF and below the end of the EM spectrum for reliable communications at range. Figure 58 depicts the relationship between competing alternatives with the three alternatives plotted against various ranges, taking into account attenuation, data rate, and power required to generate signal. The letters in the matrix represent the need for the system to be able to fulfill that relationship with a Strong Need (S) (required for successful operations), Medium Need (M) (adds value, but is not critical to success), and a Weak Need (W) (no real need for this relationship in system operations). Colors represent the feasibility of success, with green meaning that the goal of the relationship is achievable; yellow meaning that there is difficulty in meeting the requirement, and red meaning that it is unlikely or infeasible to achieve the desired goal.

What \ How		Tele-Sonar									Visible Light									Gamma Radiation								
		Attenuation			Data Rate			Power Required			Attenuation			Data Rate			Power Required			Attenuation			Data Rate			Power Required		
		< 100 db/m	< 10 db/m	< 1 db/m	High > 256 Kbps	Medium 32-256 Kbps	Low < 32 Kbps	High	Medium	Low	< 100 db/m	< 10 db/m	< 1 db/m	High > 256 Kbps	Medium 32-256 Kbps	Low < 32 Kbps	High	Medium	Low	< 100 db/m	< 10 db/m	< 1 db/m	High > 256 Kbps	Medium 32-256 Kbps	Low < 32 Kbps	High	Medium	Low
Underwater Range	Very Short < 30 yards	W	W	W	S	S	S	W	M	S	W	W	W	S	S	S	W	M	S	W	W	W	S	S	S	W	M	S
Short 30 - 2,000 yards	W	W	W	S	S	S	W	M	S	W	W	W	S	S	S	W	M	S	W	W	W	S	S	S	W	M	S	
Medium 2,000 - 10,000 yards	W	W	W	S	S	S	W	M	S	W	W	W	S	S	S	W	M	S	W	W	W	S	S	S	W	M	S	
Long > 10,000 yards	W	W	W	S	S	S	W	M	S	W	W	W	S	S	S	W	M	S	W	W	W	S	S	S	W	M	S	

**Figure 58: Undersea Communications System Alternatives Relationship Matrix**

#### 3.3.1.4.4 UNDERSEA RELAY NODE FEASIBILITY

CONCLUSIONS. Based on the assumptions used by SEA-8, no infrastructure was in place at the beginning of the scenario. This meant that no preexisting networks, SOSUS nets, or pre-laid sensors existed. This also meant everything used in this analysis was organic to the force. Based on these assumptions, all undersea communications nodes must be deployed into the AOR to create the “thinking field.”

**Sea-Floor Gateway Nodes:** The most promising gateway node is a tethered gateway buoy. Easily deployed by air, sea, and undersea systems, this relay will remain in place unless detected by enemy forces. Low visibility systems are relatively inexpensive and create the best medium between the atmospheric and undersea communications networks. It is assumed that in any littoral scenario, tethered gateway buoys will have sufficient scope of tether to secure themselves to the seafloor.

Free-floating gateway nodes work just as well as their tethered counterparts, and may be better in very deep waters, where their counterparts are unable to gain a secure footing, but currents cause them to float away from their intended locations requiring frequent reseeding based on the strength of the current.

Submarine/UUV relay nodes are considered impractical for communications relay duty due to the large number of vehicles needed to cover a significant area of the field.

#### 3.3.1.4.5 C4ISR ATMOSPHERIC PROPAGATION

FEASIBILITY CONCLUSIONS. Assuming that a forward-deployed “thinking field” of ASW sensors was required to communicate with an ASW force located more than 100 NM from the battlespace, what was the most appropriate architecture for the communications network and what propagation path was most appropriate? Figure 59 represents the relationships between the earth, sky, and space wave atmospheric propagation paths with respect to effective communications range, data rate, and required transmission power. Figure 59 indicated a strong need to achieve all levels of interaction, but some combinations were not possible (those in red). For example, ground wave frequencies demonstrate very good range possibilities, over thousands of miles, but the power required to achieve those ranges, and the low data rate, make this a less desirable option for above-water communications. Sky wave frequencies have good range and

acceptable power requirements but are very dependant on many environmental factors. On the other hand, space wave frequencies offer high data rates at relatively low power suitable for communications needs at short range, less than 5 NM between small sensors, or 12 NM to a surface ship. Furthermore, space wave frequencies lend themselves well to satellite communications, placing any two nodes in contact via communications satellites virtually anywhere in the world. For these reasons, the best alternative for connecting the ASW “thinking field” with the rest of the fleet above water are those RF frequencies above 30 MHz (VHF and above).

	Range			Data Rate			Power Required		
	Short <12 NM	Long 12 - 1000 NM	Satellite	High >256 Kbps	Medium 32-256 Kbps	Low < 32 Kbps	High	Medium	Low
Ground Wave (ELF, VLF, LF, MF)	S	S	S	S	S	S	S	S	S
Sky Wave (HF)	S	S	S	S	S	S	S	S	S
Space Wave (VHF, UHF, SHF, EHF)	S	S	S	S	S	S	S	S	S

**Figure 59: Atmospheric Communications Alternative Relationship Matrix**

3.3.1.4.6 ATMOSPHERIC RELAY NODE FEASIBILITY

CONCLUSIONS. Based on initial analysis and feasibility screening, all nodes served to fill a specific niche in the C4ISR operational environment, and therefore, were considered for future analysis. However, there are a few characteristics that make some alternatives more attractive than others. In general, any deployed asset should be used as a relay node if it holds more than one other node in communications range. This method helps to ensure that every node can communicate with every other node if it can communicate with at least one other node in the system. This is a fundamentally different problem than considering the deployment of a node for the specific function of serving as a relay. In this case, height-of-eye becomes the critical factor in determining how many nodes a relay can communicate with.

The higher the altitude of the relay, the greater the field of view and, in general, the fewer relays are needed. For example, one satellite may be able to cover an entire battlespace, where, in order to achieve the same field of sensor

communications, it may take hundreds of low altitude aircraft or surface platforms. Aside from height-of-eye, the next measure of effectiveness is relay capacity. If a satellite is operating at or near maximum capacity, it doesn't matter how many other nodes it can communicate with, it will not be able to serve as an effective relay. These conclusions were based on the specifics of the scenario; all alternatives were available for consideration.

#### ***3.3.1.5 Feasibility Screening Matrix***

In order to depict which alternatives were clearly infeasible, a feasibility matrix was constructed, shown in Figure 60. Green depicts topic feasibility and red indicates that, for the given topic, the alternative is not feasible. Only those alternatives that met all feasibility topics were forwarded for modeling analysis.

		Theoretical Feasibility	Technological Feasibility	Physical/Environmental Feasibility	Operational Feasibility	Social/Legal Feasibility	Fiscal Feasibility	Forward to Modeling and Analysis
Undersea Communications	Network Architecture							
	Centralized Network	Green	Green	Green	Green	Green	Green	Green
	Decentralized Network	Green	Green	Green	Red	Green	Red	Red
	Communications Architecture							
	Undersea Propagation							
	Gamma Radiation	Green	Red	Red	Red	Red	Red	Red
	Blue-green Laser	Green	Green	Red	Red	Green	Green	Red
	Tele-sonar	Green	Green	Green	Green	Green	Green	Green
	Undersea Relay Node							
	Sea-Floor Gateway							
	Coaxial	Green	Green	Green	*	Green	UNK	Red
	Fiber-optical	Green	Green	Green	*	Green	UNK	Red
	Copper Wire	Green	Green	Green	*	Green	UNK	Red
	Undersea Relay							
	UUV/Sumbarine Relay	Green	Green	Red	#	Green	Red	Red
	Gateway Buoy							
	Tethered	Green	Green	Green	Green	Green	Green	Green
	Free-Floating	Green	Green	Green	Green	Green	Green	Green
	Atmospheric Propagation							
	Groundwave RF	Green	Green	Red	Green	Green	Green	Red
Skywave RF	Green	Green	Red	Green	Green	Green	Red	
Spacewave RF	Green	Green	Green	Green	Green	Green	Green	
Atmospheric Relay Node								
Connected Relay	Green	Green	Green	*	Green	UNK	Red	
Surface Relay	Green	Green	Green	Green	Green	Green	Green	
Aircraft Relay	Green	Green	Green	Green	Green	Green	Green	
Satellite Relay	Green	Green	Green	Green	Green	Green	Green	
LTA (High Altitude)	Green	Green	Green	Green	Green	Green	Green	

\* For this particular scenario, it is assumed that there are no pre existing connected systems in place at scenario start.  
# Assuming a Communications Dedicated vehicle.  
UNK = Unknown

Figure 60: C4ISR Feasibility Matrix

### 3.3.2 Deployment Alternatives Generation

Alternatives Generation for deployment used the top-level functions of prepare, deliver, and sustain. By using these top-level functions all deployment options were fully explored and developed. The top-level functions were further broken down into subfunctions as a way to conduct decomposition of the various alternatives possible for deployment of the SoS.



### ***3.3.2.1 Preparation***

Alternatives Generation for preparing the SoS fell into three major categories: maintenance, modularity, and prepositioning, which ensured that the SoS could achieve maritime dominance. In order for the SoS to be effective it needed to have the capability for storage at sea and ashore for long periods of time. Also, the SoS needed to have the capability to integrate with legacy systems as well as current and future programs of record. The methodology to meet the requirements of preparing the SoS allowed for several different solutions to the ASW littoral problem of 2025.

3.3.2.1.1 MAINTENANCE. The SoS must have relatively easy maintenance requirements to ensure it is rapidly deployable. However, maintenance must not be simply limited to the material condition of the SoS, but it needed to include training to the SoS. The ability to train to the SoS is a critical component. A poorly designed SoS training program results in the SoS capabilities not being fully exploited when deployed.

When choosing a maintenance program for the SoS, it is important to keep in mind that the different components of the SoS may require different maintenance levels. The SoS may use the shipboard Maintenance, Materiel, Management (3M) systems as a benchmark for three basic levels (depot, organizational, and intermediate) when conducting maintenance.

Depending on the complexity of maintenance required for the SoS, a highly skilled maintenance specialist might be required. Yet, to achieve a high readiness for the SoS, a more detailed development of maintenance requirements may follow the use of an aviation methodology similar to Naval Aviation Maintenance Program (NAMP), OPNAVINST 4790.2J.

To keep maintenance requirements low, the SoS must be modular. This modularity allows the SoS to have short maintenance turnaround times, as components of the SoS are added and removed in a plug and play methodology. Current programs of record the SoS uses are based on a modular concept. The modular concept allows for the platform to continue its missions with fully mission capable (FMC) modules, while

partially mission capable (PMC) modules or nonmission capable modules (NMC) are placed in repair status and returned to the supply pool.

3.3.2.1.2 MODULARITY. The use of modular methodology keeps maintenance costs low and allows for a SoS that maintains a high state of readiness and permits rapid deployment because of modularity. The SoS's modularity is based on several different premises.

The design for modularity of the SoS based on mission has several advantages. The use of mission packages allows the SoS to be tailored to meet specific mission sets. Another method for the SoS to be modular is broken down by components such as sensors or power plants. This type of modularity enables the SoS to meet a wide variety of mission sets, yet also maintain a high state of readiness and be relatively easy to maintain. The modularity of the SoS allows for prepositioning around the globe in different states of readiness. By using modularity methodology, the timeline for maintenance is reduced. Modularity allows maintenance personnel to focus on specific equipment, while allowing the SoS to continue its current mission. Modules are drawn upon to replace units embedded within the SoS so they can be placed in a maintenance status.

3.3.2.1.3 PREPOSITIONING. The potential AOs affect the nature of the prepositioning and requires Alternatives Generation to ensure the SoS can meet any challenge in the littorals of 2025. The ability of the SoS to have an immediate effect is based on how the SoS is prepositioned and its state of readiness. Depending on where the SoS is determines its state of readiness and how it is deployed. A predetermined number of SoSs are ready for rapid deployment, and may be drawn from different locations worldwide. For example, only 3 SoSs may be ready for deployment from the continental US (CONUS), 5 may be ready at the theater level, with 1 in reserve at the task force level. The ability to perform modular maintenance is required whether the SoS is in CONUS, theater, or in the AOR. The SoS can be prepositioned either as a complete package or broken down for ease of transport.

### **3.3.2.2 Deliver**

The delivery of a SoS requires an effective mixture of assets to transport sensor components to the AOR. In order to achieve the objectives outlined in the Objectives Hierarchy, alternatives were broken down into two separate categories: short-term and long-term sensor coverage. Airborne delivery provides the most viable option, assuming air dominance is established, to satisfy short-term goals, while surface and subsurface delivery provides more robust long-term sensor coverage. If air dominance is not established, USW assets have to be used. The use of USW assets extend the timeline to sufficiently “seed” the AOR with the SoS due to speeds and expected enhancement of undersea assets available in the 2025.

#### **3.3.2.2.1 SHORT-TERM SENSOR COVERAGE.**

#### **AIR DELIVER**

- B-2: The B-2 Spirit is a multirole bomber capable of delivering both conventional and nuclear munitions. Capable of a large payload and an un-refueled range of 6,000 NM, the B-2 offers an excellent alternative for rapid sensor delivery with stealthness
- B-52: The B-52 presently provides air launch cruise missile carriage as well as long-range strike capabilities. Capable of flying at high subsonic speeds while at altitudes of 50,000 feet, the B-52 is capable of providing rapid delivery of sensor components to the AOR. Under current plans, the B-52 and B-2 will remain in service until approximately 2037
- B-3 Long Range Strike: The B-3 offers a Light Bomber (Manned) concept, which blends the advantages of a tactical fighter with a strategic bomber to develop a medium/long range, high payload capability (intertheater). The aircraft will utilize some level of low-observable technology, while offering a payload of 15,000 to 20,000 pounds
- P-8 Multimission Aircraft (MMA): The P-8 MMA is a long-range maritime patrol, ASW, Anti-Surface Warfare (ASuW), ISR aircraft that is capable of broad-area, maritime, and littoral operations. Plans are for the P-8 to be equipped with modern ASW, ASuW, and ISR sensors. The

versatility and endurance of the P-8 MMA will allow it to be both a delivery platform and a sensor

- F/A-18 E/F: The multimission F/A-18E/F “Super Hornet” strike fighter is an upgrade of the combat-proven night strike F/A-18C/D and offers a greater endurance by as much as 50%. The Super Hornet is capable of carrying approximately 17,750 pounds (8,032 kg) of external load on 11 separate stations from ground runways. The F/A-18 maintains a carrier recovery payload of 9,000 pounds
- F-35 Joint Strike Fighter (JSF): The JSF is a multirole fighter designed for precision engagement capability. Through this capability, a limited amount of sensor assets such as UUV or sea-web components may be deployed into the AOR
- Hyper Soar: The Hyper Soar hypersonic global range aircraft is envisioned to be able to depart CONUS, deliver payload anywhere in the world, and return to CONUS without the need to refuel. The flight capabilities are envisioned to loft outside the earth’s atmosphere at 130,000 feet, while traveling 6,700 mph (Mach 10). Payload capabilities are predicted to be similar to those of the B-2 aircraft

#### **MISSILE LAUNCH DELIVERY**

- Rocket Propulsion: Rockets may be utilized to propel sensors into position from hundreds to thousands of miles away

3.3.2.2.2 LONG-TERM SENSOR COVERAGE:

#### **SURFACE DELIVERY**

- LPD-17: The LPD-17 possesses a docking well to accommodate 2 Landing Craft Air Cushion (LCACs) or 4 LCMs (8) or 9 LCMs (6) or 20 LVTs. There are 2 spots for helicopters of up to CH-53 size: 3 AH-1Ws or 2 CH-46s or 1 CH-53 or MV-22

- Littoral Combat Ship (LCS) Flt II: LCSs are intended to support missions that enhance friendly force access to littoral areas. Access-focused missions include the following primary missions:
  - Littoral ASW, with the possibility of secondary missions
  - Mine Counter Measure (MCM)/Mine Warfare capability to allow for reliable and persistence detection
  - ISR
  - Homeland Defense/Maritime Intercept
  - SOF support
  - Logistic support for movement of personnel and supplies

Considering the projected lifecycle for LCS, it was presumed that the current (2005) planned hulls will no longer be operating in 2025, although, the first of the Flt I hulls will be delivered in 2006. A Flt II version will likely replace the initial design with similar capabilities to that of the original.

- DD(X): DD(X) is intended to provide increased stealth and ASW capabilities. The DD(X) will also deploy with 2 SH-60 LAMPS-capable helicopters capable of enemy submarine detection and prosecution.
- TSSE Surface Ship Alternative: The TSSE surface design will be capable of operating at high speeds (possibly 60 knots), carrying large numbers of sensors for deployment in high volumes. Because of the relative small size of its design, this ship will provide near-stealth capability.

## **SUBSURFACE DELIVERY**

- SSGN-726 Ohio: “The Ohio class cruise missile submarine (SSGN) program entails the refueling and conversion of the four nuclear ballistic missile submarines (SSBNs) to dedicated cruise missile launch submarines to support the Land-Attack/Strike mission.”<sup>94</sup> The SSGN will also support SOF missions through two large vertical launch tubes, which serve as lockout chambers. The SSGN is capable of hosting the Advanced SEAL

---

<sup>94</sup> Randall Fairman, LCDR, USN, “SSGN 726 Class Conversion,” [globalsecurity.org, http://www.globalsecurity.org/military/library/news/2004/03/mid-040305-navsea.htm](http://www.globalsecurity.org/military/library/news/2004/03/mid-040305-navsea.htm), (accessed 15 August 2005)

Delivery System (ASDS) and Dry Deck Shelter on its upper deck. The payload capacity of the SSGN may be used to support other off-board systems such as large UUVs and autonomous underwater vehicles.

- SSN Fast Attack Submarine (FAS): The SSN FAS will offer high transit speeds with increased endurance. FASs will be capable of increased internal payload for auxiliary vehicles such as UUVs and submersibles. A free-flooding weapons bay will also be reconfigurable to accommodate off-board sensors.
- TSSE Submarine Alternative: The TSSE subsurface design will be capable of deploying with stealth near enemy shorelines. This platform is intended to be capable of carrying large numbers of sensors for deployment in high volumes.

### ***3.3.2.3 Sustain***

Alternatives Generation for sustainment focused on operational factors of time, space, and distance. These key factors applied not only to the SoS, but also to those elements supporting the SoS. The first step in achieving optimum sustainment of sensor assets was to determine the support and logistical requirements of each sensor asset deployed. Several categories considered for support were:

- No sustainment required: Sensor asset does not require support nor does it require recovery
- Light: Must be recoverable for routine maintenance or to repair damaged components
- Medium: Must be recoverable for routine maintenance, damage repairs, change out power supplies or refueling
- Heavy: Must be recoverable for rearming of weapons, data retrieval, intensive maintenance, damage repairs, change out power supplies, or refueling

#### **3.3.2.3.1 OTHER SUSTAINABILITY CONSIDERATIONS.**

Depending on sensor capabilities or mission requirements, certain components of the SoS

might be sustainable for a couple of hours, while others may require sustainment on the order of 10 to 30 days or longer.

The SoS requires a trade-off of long dwell times relative to capability. An example would be the long dwell times for intelligence gathering to determine hostile operating patterns versus short dwell times, but with high capability to help localize and neutralize enemy assets.

SoS sustainment may be achieved through a form of “graceful degradation.” Sensor components may lose maneuverability, but still be able to provide capabilities for sensing and reporting beyond a certain remaining power point. Similarly, sensor components such as captor-enabled UUVs and mines may default to a prosecute mode when it has reached a prespecified remaining power point, where remaining power is sufficient for only one enemy prosecution (suicide mission). The SoS may also go to safe mode depending on ROE.

The ability to sustain the SoS is determined by the platforms. Surface and subsurface-based assets provide logistical support capabilities for supply, recovery, and maintenance of sensor assets.

Deployment methods such as “fire and forget” increase the dependence on these logistics assets if the component of the SoS is deemed recoverable. Sensor assets deemed expendable reduce dependence on logistics assets; however, risk of enemy recovery proved expendability as an infeasible option.

### **3.3.3 Prosecution Alternatives Generation**

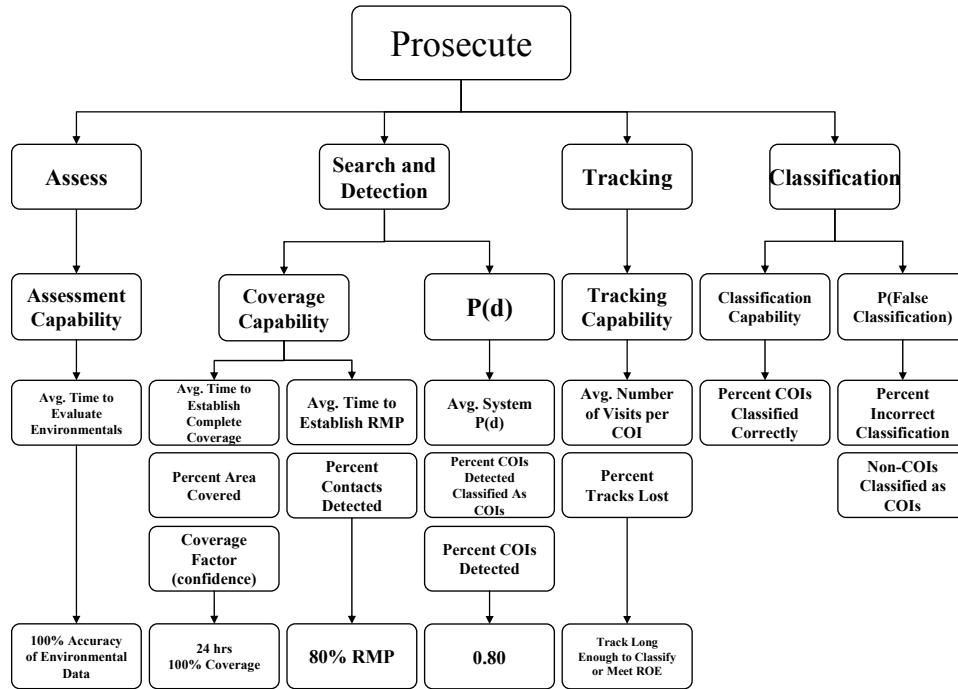
The alternative sensors generated by SEA-8 must be able to satisfy the Effective Need of a “SoS that denies enemy underwater forces (submarines and UUVs) effective employment against friendly forces within the littorals during the 2025 time frame” with some or all of the following capabilities: (a) Battlespace preparation and monitoring, (b) Persistent detection and cueing, (c) Combined arms prosecution, (d) High volume search and kill rates, (e) Nontraditional methods, and (f), Defense-in-depth.<sup>95</sup>

Objectives of the “Prosecute” Team were outlined in Section 2.2.3 (Objectives Hierarchy) and are shown in Figure 61. The primary objectives of assess, search and

---

<sup>95</sup> Meyer Institute of Systems Engineering *Memorandum for SEA8 Students*, Integrated Project Tasking Letter, 28 March 2005.

detection, tracking, and classification will help define what each of the alternatives should encompass concerning sensor and platform mix. Figure 61 shows the objectives, MOEs (capabilities), the MOPs (represented in three rows), and goals for each objective.



**Figure 61: Functional Objectives Hierarchy for Prosecute**

All of the proposed sensors, to include sensors that are being researched and developed for future use and their respective operational platforms, were all evaluated. They are categorized into air and space, surface, and subsurface assets to include the acoustic active and passive, nonacoustic, including nontraditional methods used by the sensors to detect and classify enemy submarines and UUVs.

Potential approaches to solving the ASW in the littorals problem in 2025 have taken into consideration issues already addressed by today’s ASW groups. Some parts of these potential approaches were incorporated into the final five alternatives that were decided on by SEA-8. For example, one of these potential approaches was DARPA’s Netted Search, Acquisition and Targeting (NetSAT) program that

...demonstrated a networked approach for improved attack performance [which evaluated the use of] a sonobuoys field to help



identify, locate and mitigate the impact of countermeasures and target evasion tactics on torpedo operation.<sup>96</sup>

John R. Potter is correct in the conclusions section of his paper on “Challenges of Seeing Underwater—A Vision for Tomorrow,” where he stated that:

The challenge is not in identifying useful technologies, but in bringing them to bear effectively on the tactical problems of naval combat scenarios. These technologies will make their mark when integrated using the following features:

- Diverse platform types (surface and submarine vessels, ROV’s, AUV’s, drones, aircraft and satellite) will be used in concert.
- Diverse sensing technologies (multi-static passive and active, covert active, VHF active, laser) will be employed in a coordinated search over all useful ranges, bandwidths, resolutions and degrees of covertness required to span interests and needs.
- Systems will employ ‘smart’ processing and AI in the detection, classification and prediction of environmental developments.<sup>97</sup>

These statements are backed up by Forecast International (a corporation established to provide market intelligence and analysis for the aerospace, defense, military electronics, and power system industries) in their recognition of a trend of merging technologies such that limitations on weight, space, and endurance constraints will no longer conflict, and any sensor can potentially be installed on any platform to provide on-time, accurate, and faster processing for increased capability across a wide gamut of assets.<sup>98</sup>

All of the current assets, including those assets being developed, have to be taken into account when generating alternatives. Some sensors have better range than other sensors, some platforms can arrive on station earlier than others, and the platform selection has to also depend on the sensor suite present on each.

Alternatives generated in this phase of the systems engineering process do not necessarily have to follow the status quo of platform-centric battle-group mentality. They

---

<sup>96</sup> Mark Hewish, *No Hiding Place: Undersea Networks Help Flush Out Littoral Targets*, Jane’s International Defense Review, 14 May 2004, <http://www4.janes.com/K2/>, (accessed 8 November 2005).

<sup>97</sup> John R. Potter, “Challenges of Seeing Underwater—A Vision for Tomorrow,” Acoustic Research Laboratory, Electrical Engineering Department and Tropical Marine Science Institute, National University of Singapore, <http://arl.nus.edu.sg>.

<sup>98</sup> *The Market for Airborne ASW Sensors* produced by Forecast International, 2004, p. 13.

can vary from the notional thought processes when a potential solution can help achieve the goals established during the Objectives Hierarchy.

SEA-8 developed four viable alternatives for conducting ASW in the littorals. Each of the alternatives is centered around a unique concept, as implied by their respective names. The alternatives can be described as follows: (1) Tripwire; (2) TSSE; (3) War of Machines; and (4) LAG. The four alternatives generated provide a common baseline for each of the SEA-8 teams to operate from.

Two aspects important to the scenario are addressed in each alternative. The first is the concept of “harbor gate.” This concept is built into the alternatives with sensors acting as tripwires for submarines entering and leaving ports. The second issue is the concept of networked sensors and is also incorporated into each of the alternatives, providing for the ability to detect, track, and classify any underwater enemy submarine or UUV present in the AOR.

#### ***3.3.3.1 Air- and Space-Based Sensors***

The air component breakdown summarizes the air components. Figure 62 does not mention the near-term and far-term developments that are being envisioned or purchased now for use in the future because a Needs Analysis only covers current problems, not potential future solutions. Those assets (or potential assets) are listed in Section 3.3.3.1.9.

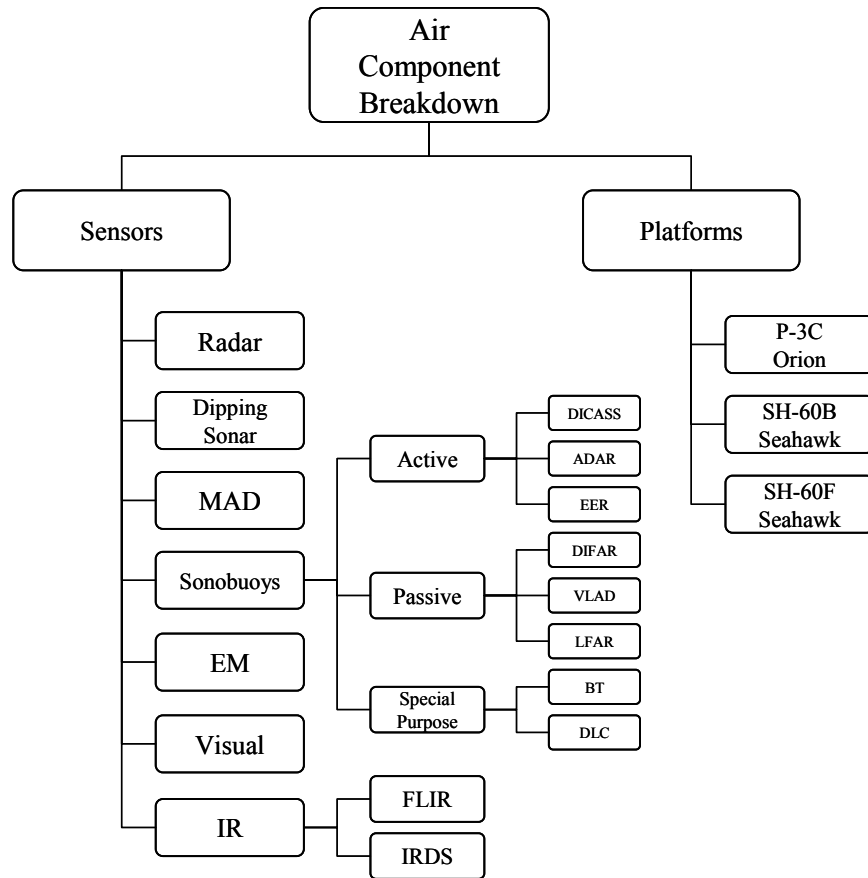


Figure 62: Air Component Breakdown

3.3.3.1.1 RADAR SENSORS. Radar sensors onboard aircraft are commonly used to detect exposed periscopes and submarine hulls. These sensors are strictly nonacoustic as they do not evaluate underwater sound. Radar sensors on ASW aircraft typically have a reach defined by both the sensor strength and the aircraft reach. For ASW, this range is between 40 and 350 NM.<sup>99</sup> These sensors include the following:

<u>Nomenclature</u>	<u>Platform</u>	<u>Type</u>
AN/APS-115	P-3C	X-band sea surveillance/ASW radar
AN/APS-124	SH-60B	Sea surveillance/ASW radar
AN/APS-137	P-3C	Pulse doppler, X-band sea surveillance/ASW radar <sup>100</sup>

<sup>99</sup> Andreas Parch, "AN/APR to AN/APS-EquipmentListing," <http://www.designation-systems.net/usmilav/jetds/an-apr2aps.html>, (accessed 30 October 2005).

<sup>100</sup> Ibid.

3.3.3.1.2 MAD SENSORS. In ASW, MAD sensors are used to detect “manmade differences in the earth’s magnetic fields.”<sup>101</sup> Mainly changes can be caused by the passing of large ferrous objects, such as ships, submarines, or even aircraft through the earth’s magnetic field.

MAD sensors have special requirements that limit their effectiveness. For example, the ASW aircraft must almost be exactly over or very near the submarine’s position to detect the change or anomaly. The direction traveled by both the aircraft and the submarine relative to the earth’s magnetic field is also a factor.

In order to detect an anomaly, the MAD head of the aircraft tries to align itself with the noise produced by the Earth’s magnetic field. Through this alignment, the noise appears as a near-constant background noise value which enables the operator to recognize any contrasting submarine magnetic anomalies from the background noise. However, any rapid changes in aircraft heading or the operation of certain electronic equipment and electric motors can produce so much aircraft electromagnetic noise such that the detection of the submarine's magnetic signature is virtually impossible. Special electronic circuitry is enabled to compensate and null out this aircraft magnetic noise. Additionally, the MAD head is placed the farthest distance away from all the interfering sources.<sup>102</sup>

Detection range is normally related to the distance between the aircraft sensor and the submarine. The strength of the anomaly will depend on the size of the submarine and its hull material composition. MAD sensors could play key roles in the littoral ASW, especially in green water, with effectiveness affected by “undersea wreckage, debris, and other neutral returns from the seabed.”<sup>103</sup>

The following listing delineates the nomenclature of MAD sensors and their respective ASW platforms:

---

<sup>101</sup> Naval Sea Systems Command, “Background of Air ASW Sensors,” Crane, IN, <http://sonobuoy.crane.navy.mil/sensors.htm>, (accessed 30 October 2005).

<sup>102</sup> “ASW Sensors,” globalsecurity.org, [Internet, WWW], 300 N. Washington St., Suite B-100, Alexandria, VA 22314, <http://www.globalsecurity.org/military/systems/aircraft/asw3.htm>, (accessed 25 July 2005).

<sup>103</sup> *The Market for Airborne ASW Sensors*, Forecast International, 2004, p. 16.

<u>Nomenclature</u>	<u>Platform</u>	<u>Type</u>
AN/ASQ-81	P-3C, SH-60B	MAD
AN/ASQ-208	P-3C	Advanced MAD with digital processing <sup>104</sup>

3.3.3.1.3 EM SENSORS. ASW aircraft EM sensors are designed to selectively search for specific submarine radar signals. Detection of these submarine-based electronic emissions is dependent on a submarine commander's willingness to operate their radar. Although this sensor is not a primary sensor in ASW, "its potential presence deters the operation of submarine radar systems forcing the submarine commander to rely on other less accurate sensors to find targets."<sup>105</sup>

EM sensors and their respective ASW platforms are listed below:

<u>Nomenclature</u>	<u>Platform</u>	<u>Type</u>
AN/ALQ-78	P-3C	ESM system
AN/ALR-66	P-3C	Multipurpose ESM suite for LAMPS system
AN/ALQ-142	SH-60B	LAMPS ESM set <sup>106</sup>

3.3.3.1.4 IR SENSORS. IR sensors operate in much the same way as radars, detecting submarine masts or surfaced structure. FLIR or IRDS are the two major passive systems used in ASW. With this sensor suite, medium detection ranges can be obtained that are comparable to, or even better than, normal visual search ranges, especially at night when there is a noticeable difference in temperature between the source and the background environment. With the use of IR systems at night, the need to physically illuminate the ocean surface with searchlights or flares no longer exists.<sup>107</sup>

FLIR sensors can also be used (by increasing their sensitivity) for detecting submarines underwater. This is accomplished by the sensor picking up temperature differences between the submarine's wake and the surrounding sea water. Making FLIR ultrasensitive, however, will also mean that it picks up heat sources other

<sup>104</sup> <http://www.designation-systems.net/usmilav/jetds/an-asq.html>, (accessed 8 November 2005).

<sup>105</sup> "ASW Sensors," [globalsecurity.org](http://www.globalsecurity.org), [Internet, WWW], 300 N. Washington St., Suite B-100, Alexandria, VA 22314, <http://www.globalsecurity.org/military/systems/aircraft/asw3.htm>, (accessed 25 July 2005).

<sup>106</sup> Andreas Parch, "AN/APR to AN/APS-Equipment Listing," <http://www.designation-systems.net/usmilav/jetds/an-asq.html>, (accessed 8 November 2005).

<sup>107</sup> Andreas Parch, "AN/APR to AN/APS-Equipment Listing," [globalsecurity.org](http://www.globalsecurity.org), [Internet, WWW], 300 N. Washington St., Suite B-100, Alexandria, VA 22314, <http://www.globalsecurity.org/military/systems/aircraft/asw3.htm>, (accessed 25 July 2005).

than submarine wakes, including wakes from merchant vessels, “effluent from industrial plants and power stations, outflow from rivers and streams, and many other false contacts”<sup>108</sup> that reduce its effectiveness in the littoral region.

#### 3.3.3.1.5 VISUAL SENSORS.

Many submarine contacts are still detected using visual scanning techniques. These techniques are sometimes augmented by sophisticated binocular and other electro-optical devices. Submarine commanders are still wary of being visually spotted and maintain a safe speed when their periscopes are exposed so that their telltale wake remains indistinct compared to the background sea clutter. The position of the Sun and the Moon as well as the direction of the ocean waves are all factors the submarine commander must consider in order to remain unobserved. In some regions of the world, phosphorescent marine organisms illuminate a submerged submarine allowing it to be visually spotted. Additionally, some aircrews may use night vision goggles to aid in visual detection at night.<sup>109</sup>

3.3.3.1.6 SONOBUOYS. Sonobuoys aid in the ASW fight by providing the capability to detect, localize, identify, and track potential hostile submarines. Sonobuoys are also used in the fleet to determine environmental conditions that assist operational commanders in their determination of the best search tactics to employ in addition to communicating with friendly submarines.

Sonobuoys can be classified as passive, active, and special purpose. Passive sonobuoys quietly listen for acoustic (sound) energy from a target, while active sonobuoys emit a sound pulse (ping) to generate an echo from the target. Special purpose sonobuoys provide information about the environment such as water temperature, ambient noise level, and salinity, among others, all of which aid the decision maker in determining optimum type and quantity of sensors to use in the ASW search.

Sonobuoys sensors that can be launched from the P-3C, SH-60B, and SH-60F, are:

---

<sup>108</sup> *The Market for Airborne ASW Sensors*, Forecast International, 2004, p. 12.

<sup>109</sup> *Ibid.*

<u>Nomenclature</u>	<u>Type</u>	<u>Short Name</u>
AN/SSQ-36	Bathythermograph	BT
AN/SSQ-53D/E	Directional Frequency Analysis and Recording	DIFAR
AN/SSQ-57B	Low Frequency Analysis and Recording	LFAR
AN/SSQ-62B/C/D/E	Directional Command Activated Sonobuoy System	DICASS
AN/SSQ-77B	Vertical Line Array Directional Frequency	VLAD
AN/SSQ-86	Data Link Communications	DLC
AN/SSQ-101	Air Deployable Active Receiver	ADAR
AN/SSQ-110	Extended Echo Ranging	EER
AN/SSQ-110/A	Improved Extended Echo Ranging	IEER <sup>110</sup>

3.3.3.1.7 DIPPING SONAR. A dipping sonar employs a high sink rate transducer body to detect and localize underwater targets. It is the active echo ranging that determines a target's range and bearing, and opening or closing rate relative to the aircraft's position. The system also provides target classification clues.

The AN/AQS-13F (dipping sonar) works well for redetecting contacts, target localization, and weapon delivery against shallow and deep water threats. The platform it uses is the SH-60F found on aircraft carriers.<sup>111</sup>

3.3.3.1.8 PLATFORM COMPONENTS. Three main component aircraft carry all of today's Navy ASW sensor suites, and they are the LAMPS helicopter (found onboard most surface ships), P-3C (shore-based support aircraft), and the P-8 (MMA).

## LAMPS

LAMPS helicopters support ASW in many ways. They were designed to extend and enhance the capabilities of surface combatants in ASW and increase the effective operational range for the weapons systems fitted on the helicopter. By operating off the deck of surface vessels, the aircraft extends the detection, classification, location, and

---

<sup>110</sup> Department of the Navy, Chief of Naval Operations, *Request for Approval of Proposed Navy Training Systems Plan (NTSP) for the Navy Consolidated Sonobuoys N88-NTSP-A-50-9910C/A*, 11 August 2000, [http://www.globalsecurity.org/military/library/policy/navy/ntsp/Sonobuoys\\_a.pdf](http://www.globalsecurity.org/military/library/policy/navy/ntsp/Sonobuoys_a.pdf), (accessed 8 November 2005).

<sup>111</sup> L-3 Ocean Systems, [Internet, WWW], L-3 Communications, 15825 Roxford Street, Sylmar, CA 91342, [http://www.l-3com.com/os/airborne\\_13f.html](http://www.l-3com.com/os/airborne_13f.html).

attack capabilities where needed to increase LOS and range capabilities of the surface ship.

In an ASW mission, the SH-60B is deployed when a suspected threat has been detected by the surface ships sonar or off-board cueing. It proceeds to the estimated target area, where sonobuoys are dropped in the water in a pattern designed to trap the target. The acoustic signatures detected by the sonobuoys are transmitted over a radio frequency link to the aircraft where they are analyzed, coded and retransmitted to the surface ship for interpretation and analysis. When the location of the threat is determined, the aircraft descends near the ocean's surface for final confirmation using active sonobuoys, passive directional sonobuoys or by trailing a MAD behind the aircraft. On final confirmation by any of these methods, an attack can be initiated. The extension of the surface combatant's sensor, tactical control and attack capabilities is achieved by using a secure duplex digital datalink that transfers acoustic, electromagnetic and command data and voice from the SH-60B, and command data and voice to the SH-60B.<sup>112</sup>

### **P-3C**

The P-3C MPA is a land-based, long-range, ASW patrol aircraft with sonobuoys, a MAD, MK-50 torpedo, and MK-60 mines. The P-3C has a 10- to 13-hour flight time that allows the P-3C to search large volumes of sea space and detect the presence of enemy submarines.

### **P-8 (MMA)**

The P-8 MMA is a long-range ASW, ASuW, ISR aircraft capable of broad-area, maritime and littoral operations, and was designed to replace the P-3C.<sup>113</sup> It is important to note that the P-8 will be included in the future 2025 littoral USW architecture and is introduced here as a definition for future force composition.

#### **3.3.3.1.9 NEAR AND FAR TERM DEVELOPMENTS.**

Private contractors working for/with the US Navy are developing sensors that are deployed from aircraft or communicate their findings to aircraft. While not all of the development items below will exist in 2025, some may exist and have the potential for further development in the near term, making them valuable ASW assets for 2025 in the

---

<sup>112</sup> *Jane's Underwater Warfare Systems*, (London, England: Jane's Information Group, 10 June 2005).

<sup>113</sup> Boeing Company, "MMA Program," <http://www.boeing.com/defense-space/military/mma/flash.html>, (accessed 15 July 2005).



littorals. While these systems are not included in the alternatives generated, they should be considered as essential to the ASW problem in 2025.

All of the developmental programs listed below were extracted from the Program Executive Office's *Acquisition Opportunities for Early ASW Improvement: CNO ASW Offsite* presentation:

1. Deployable Autonomous Distributed System (DADS), designed for the littorals to detect and classify submerged submarines based on detection and processing of acoustic/magnetic signals. DADS combines acoustic and electro-magnetic sensor feedback from multiple sources and creates data fusion on the output side. This asset would provide shallow-water cueing capability with the ability to be rapidly deployed, low cost, and survivable,<sup>114</sup> and is intended to “demonstrate improvements in the USN’s ability to conduct ASW and ISR missions in the littorals.”<sup>115</sup>
2. Network-Enabled ASW (NEASW), a system of DICASS sonobuoys (AN/SQQ-62 transducers) that are network-enabled and deployed as a distributed field of multi-static active sensors for rapid detection, localization, and classification. Remote stations provide communication on a USV, research vessel, or a close-in shore station.<sup>116</sup>
3. Reliable Acoustic Path Vertical Line Array (RAP VLA) comprises an air deployed vertical line array for passive detection, localization, and tracking of quiet submarines using reliable acoustic path energy. This sensor communicates its findings to a tactical platform or sonobuoy via acoustic communication link.<sup>117</sup>
4. Littoral Volumetric Acoustic Array (LVAA), a rapidly deployed high gain volumetric sensor for passive and active detection, localization, and tracking of quiet submarines in a shallow water or deep surface duct environment. This sensor uses in-buoy data compression, ADAR data link,

---

<sup>114</sup> Program Executive Office Integrated Warfare Systems, “Acquisition Opportunities for Early ASW Improvement,” CNO ASW Offsite PowerPoint presentation, 8 March 2005, slide 150.

<sup>115</sup> Mark Hewish, *No Hiding Place: Undersea Networks Help Flush Out Littoral Targets*, Jane’s International Defense Review, 14 May 2004, <http://www4.janes.com/K2/>, (accessed 8 November 2005).

<sup>116</sup> Program Executive Office Integrated Warfare Systems, “Acquisition Opportunities for Early ASW Improvement,” CNO ASW Offsite PowerPoint presentation, 8 March 2005, slide 152.

<sup>117</sup> *Ibid.*, slide 174.

tactical platform detection/classification processing and will have the ability for satellite link in the future.<sup>118</sup>

5. Improved Extended Echo Ranging (IEER), an air-deployed wide-area active search for ASW with shallow received ADAR that consists of large fields of sources and receivers in the deep, shallow, and littoral water environments.<sup>119</sup>
6. Advanced Extended Echo Ranging (AEER), also an air-deployed wide-area active search for ASW but with coherent sources (AN/SQQ-125) that enable it to search in complex littoral environments discriminating between moving and non-moving objects thus avoiding concerns with impulsive sources.<sup>120</sup>
7. Airborne Radar Periscope Detection and Discrimination (ARPDD), a modified version of AN/APS-137(V)5 pulse doppler radar that has increased sensitivity over conventional radars which may equate to a higher probability of detection. Increased processing power and automatic target recognition are also part of this sensor's capabilities.<sup>121</sup>
8. Electro-Optic Passive ASW Sensor (EPAS), a combination of four integrated advanced nonacoustic ASW sensor technologies including multi-spectral, IR thermal, bioluminescence, and digital MAD/ELF in one sensor. This sensor increases current capabilities by allowing for daytime and nighttime 3D detection using multiple sensors simultaneously.<sup>122</sup>
9. P-3 Infrared Mode W, a passive infrared detection system for improved ASW detection providing increased sensitivity and wake detection capability.<sup>123</sup>
10. European Synthetic Radar Satellites (ERS), a satellite that is capable of measuring atmospheric and surface properties accurately by using "active microwave emissions to collect global measurements and images

---

<sup>118</sup> Ibid., slide 177.

<sup>119</sup> Ibid., slide 220.

<sup>120</sup> Ibid., slide 222.

<sup>121</sup> Ibid., slide 226.

<sup>122</sup> Ibid., slide 231.

<sup>123</sup> Ibid., slide 251.

independent of time of day or weather conditions.”<sup>124</sup> In addition to sensing environmental data, this satellite can detect and classify ships using synthetic aperture radar (SAR) wake images. A French satellite exists today that can measure the ocean surface coloration (or discoloration) allowing the analyst to discriminate a submerged vessel that stirs up the water column and changes the color of the water in its wake.<sup>125</sup>

11. Visual EM systems, such as a hyper spectral camera with a very high frame rate, can image the ocean, and with some processing, be used to discriminate differences in color to detect submerged submarines.
12. Laser airborne bathymetry systems (such as light detection and ranging, or LIDAR) can be used to survey the ocean up to depths of 50m (shallow water) by analyzing the high resolution and detail in the corresponding images. Unfortunately, “laser scanning imaging can provide excellent resolution for close-up classification, but cannot yet fulfill the need for detection at any but the closest ranges.”<sup>126</sup>

### ***3.3.3.2 Surface Sensors***

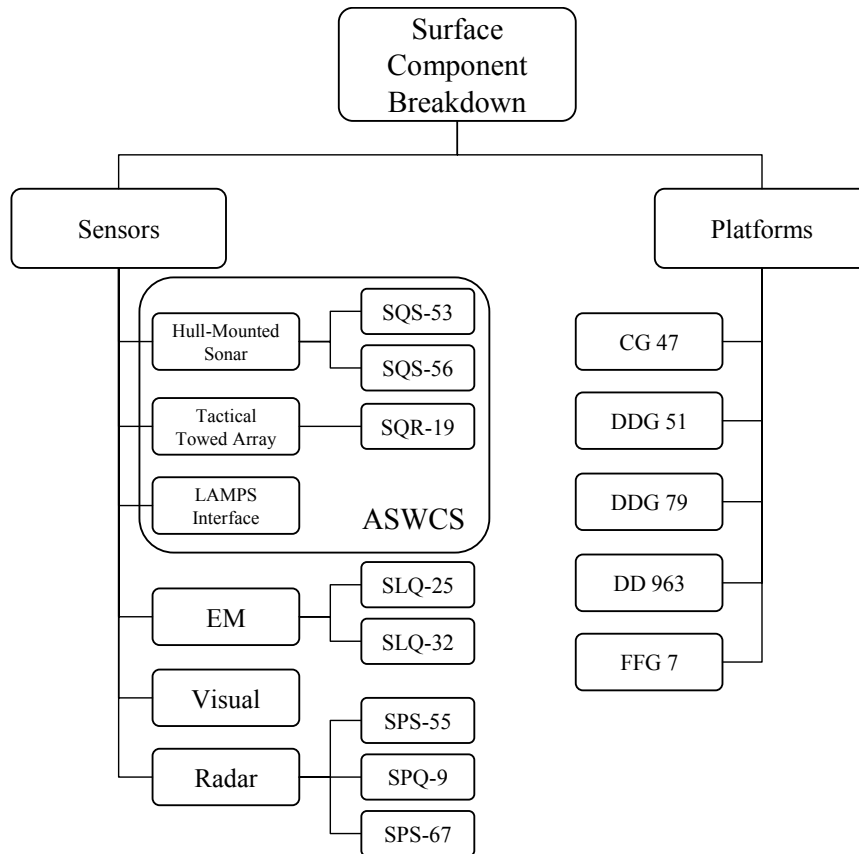
The ASW surface components are listed in Figure 63 in order to help illustrate the different sensors in use today. As with the air component, surface components are also broken down by platform as well as by sensors. The exception in the surface component is that almost every surface platform carries the same acoustic sensors. The difference is in the version, upgrade, or original install found on each platform. Newer ships have up-to-date sensors that may be more technologically advanced.

---

<sup>124</sup> John R. Potter, “Challenges of Seeing Underwater—A Vision for Tomorrow,” Acoustic Research Laboratory, Electrical Engineering Department and Tropical Marine Science Institute, National University of Singapore, <http://arl.nus.edu.sg>.

<sup>125</sup> Ibid.

<sup>126</sup> Ibid.



**Figure 63: Surface Component Breakdown**

Table 2 lists specific sensor suites and organic assets for each of the SoS surface components. The LCS is included for near future decomposition and will be included in the 2025 SoS architecture.

	SONAR			RADAR			EW	HELO	UAV	USV
Platform	SQS-53	SQS-56	SQR-19	SPS-55	SPS-67	SPQ-9	SLQ-32			
CG-47	X		X	X		X	X	2		
DDG-51	X		X		X	X	X			
DDG-79	X			X	X		X	2		
DD-963	X		X	X		X	X	2		
FFG-7		X	X				X	2		
LCS								1	3	2

**Table 2: Surface Force ASW Capabilities**

3.3.3.2.1 RADAR SENSORS. As in aircraft, radars are nonacoustic tools used to detect exposed periscopes and submarine hulls that have surfaced. As shown in Table 2, three radar sensors are part of today’s fighting ships. The SPQ-9 has the shortest range (approximately 20 NM),<sup>127</sup> but is a very efficient radar that

<sup>127</sup> “ASW Sensors,” <http://www.globalsecurity.org/military/systems/ship/systems/an-spq-9.htm>, (accessed 8 November 2005).

actively discriminates between environmental clutter and low, sea-skimming contacts with a high degree of accuracy. The SPQ-9 also forms part of the MK-86 gun fire control system (GFCS) that coordinates shots from the 5"/54 gun mounts. This radar also has the ability to detect and track low, sea-skimming missiles.

The SPS-55 is the most common surface search radar and is found on surface ships as the primary surface search radar used for navigation and the tactical picture. This radar has a longer range than the SPQ-9 (approximately 50 NM),<sup>128</sup> but does not discriminate as well between environmental clutter and the return from a contact. The AN/SPS-67 radar is also a short-range (up to 50 NM), two-dimensional radar used primarily for surface-search and navigation.

3.3.3.2.2 SONAR SENSORS. The SQS-53 is a hull-mounted, active and passive high-power (190 kW), long-range, cylindrical array with the ability to detect, track, and classify underwater targets. Other uses include underwater communications, countermeasures against acoustic underwater weapons, and oceanographic recording. It operates on both passive and active modes. Active modes of the SQS-53 are: (1) surface duct, with a range of up to 10 NM; (2) bottom bounce; and (3) convergence zone with a range of up to 34.5 NM.<sup>129</sup>

The SQS-56 is a modern, bow-mounted, active/passive, short-range sonar that is operated by the FFG platforms. Specific operating parameters for the SQS-56 are classified.

The SQR-19 is a passive, towed sensor array designed to give surface vessels long-range detection and tracking of submarines. The SQR-19 provides omnidirectional, long-range, passive detection and classification of submarine threats at tactically significant own-ship speeds in seas of up to state 4, using an array towed on a 1,707-meter cable to provide tow depths down to 365 meters.<sup>130</sup>

Hull-mounted sonars and tactical, towed arrays are linked into a common tactical system onboard surface ships called the ASWCS, as represented in the shaded region of Figure 63. This system also links communications from the LAMPS

---

<sup>128</sup> "ASW Sensors," <http://www.globalsecurity.org/military/systems/ship/systems/an-sps-55.htm>, (accessed 8 November 2005).

<sup>129</sup> *Jane's Underwater Warfare Systems*, (London, England: Jane's Information Group, 10 June 2005).

<sup>130</sup> *Ibid.*

helicopter that involve sonobuoy, radar, and IR detections. Having the ability to combine sensor inputs allows the operators and the system to correlate contacts verified on each of the different sensors. This reduces the probability of false detections inherent with environmental clutter, giving the operational commander a higher confidence level concerning detection capabilities.

3.3.3.2.3 EW SENSORS. EW sensors, such as the SLQ-32, are similar to the aircraft EM sensors in that their purpose is to detect signal emitters used by shore facilities as well as submarines, surface ships, aircraft, and missiles. While its primary purpose is not ASW, this sensor can be used to intercept signals originating from submarines.

3.3.3.2.4 NEAR- AND FAR-TERM DEVELOPMENTS. All of the developmental programs listed below were extracted from the Program Executive Office's *Acquisition Opportunities for Early ASW Improvement: CNO ASW Offsite* presentation. Additional sources were researched in order to provide a more in-depth analysis of each sensor.

1. Medium N Sensors, sensor buoys that can be deployed from ships to form a barrier of volumetric array of hydrophones that provide vertical and horizontal beam forming to eliminate excess surface noise and provide better detection capabilities.<sup>131</sup>
2. Advanced Distributed System (ADS), a rapidly deployable (“distributed fields of battery powered disposable hydrophone arrays”),<sup>132</sup> self-powered, passive undersea acoustic surveillance system deployed from surface ships in the form of a barrier. This sensor comprises two strings of four arrays that are manually deployed. A riser cable connects to the surface ship (LCS-like platform) or a shore station to develop contact reports.<sup>133</sup>  
“Major targets for the ADS will include quiet nuclear-powered

---

<sup>131</sup> Program Executive Office Integrated Warfare System, “Acquisition Opportunities for Early ASW Improvement,” CNO ASW Offsite PowerPoint presentation, 8 March 2005, slide 156.

<sup>132</sup> Mark Hewish, *No Hiding Place: Undersea Networks Help Flush Out Littoral Targets*, Jane's International Defense Review, 14 May 2004, <http://www4.janes.com/K2/>, (accessed 8 November 2005).

<sup>133</sup> Program Executive Office Integrated Warfare System, “Acquisition Opportunities for Early ASW Improvement,” CNO ASW Offsite PowerPoint presentation, 8 March 2005, slide 146.

submarines, diesel-electric submarines running on battery power, ships exiting or entering port and vessels conducting minelaying operations.”<sup>134</sup>

3. Unmanned Lightweight Towed Arrays (UTAS), lightweight towed arrays that are sea state limited, specifically designed for the USV (towed by the unmanned rigid hull inflatable boat ((RHIB) found on the LCS). This sensor can be deployed to high risk areas where large vessels cannot operate and can act as receivers for either impulsive or coherent sources.<sup>135</sup>
4. Mobile Off-Board Source (MOBS), this sensor also relies on an unmanned surface vehicle (USV), specifically designed for the USV to deploy a slotted cylinder low frequency active source sensor for underwater acoustic detections.
5. High Gain Volumetric Array (HGVA), this sensor system is fixed or towed by a surface or subsurface vessel such as the LCS, SURTASS, UUV, USV, SSN, or SSGN that provides significant area search and sustained cueing. It comprises 6 stacked Twin-Line array configuration to exploit three dimensional ocean noise structure. It is passive only, and uses human processing.<sup>136</sup>
6. RAP VLA, comprises an surface ship deployed vertical line array to deep water for passive detection, localization, and tracking of quiet submarines using reliable acoustic path energy. This sensor communicates its findings to a tactical platform or sonobuoy via acoustic communication link.<sup>137</sup>
7. LVAA, a rapidly deployed high gain volumetric sensor for passive and active detection, localization, and tracking of quiet submarines in a shallow water or deep surface duct environment. This sensor uses in-buoy data compression, ADAR data link, tactical platform

---

<sup>134</sup> Mark Hewish, *No Hiding Place: Undersea Networks Help Flush Out Littoral Targets*, Jane's International Defense Review, 14 May 2004, <http://www4.janes.com/K2/>, accessed (8 November 2005).

<sup>135</sup> Program Executive Office Integrated Warfare System, “Acquisition Opportunities for Early ASW Improvement,” CNO ASW Offsite PowerPoint presentation, 8 March 2005, slide 161.

<sup>136</sup> *Ibid.*, slide 169.

<sup>137</sup> *Ibid.*, slide 174.

detection/classification processing and will have the ability for satellite link in the future.<sup>138</sup>

8. Scalable Improved Processing Sonar (SIPS), a COTS adjunct processor to the SQQ-89 sonar system (found on ships that have the SQR-19 and/or SQS-53 hull mounted sonar) that incorporates passive acoustic and torpedo recognition functions. This sensor improves processing and display capabilities of an existing sonar system. It also adds additional acoustic intercept sensors to reduce false alarm rates and maintain the probability of detection.<sup>139</sup>
9. MFTA, this sensor also improves on an existing sensor (SQR-19 Towed Array) to provide significant performance gains in passive detection, torpedo defense, and acoustic transient detection.
10. Radar Augmentation for Periscope Identification (RAPID), an augment to the SPS-73 surface and navigation radar that uses real-time pattern recognition techniques tuned to tactical submarine operations in order to provide automatic alerts (dependent on multiple mast exposures).
11. Receive While Transmit (RWT) is a continuously transmitting active sonar providing for longer detection ranges with less latency.
12. Low Frequency Active Sonar (LFAS), a sensor primarily used to detect submarines at ranges that prohibit unsuspected attacks, i.e., outside torpedo range. If a submarine is detected at a longer range, offensive forces have time for engagement (force it to leave the operating area or neutralize it).<sup>140</sup>
13. Parametric Sonar, an active sonar for shallow water sensor with the ability to reduce reverberation (backscattering from bottom and surface interaction) and search the water column by steering a beam through the region of interest.<sup>141</sup>

---

<sup>138</sup> Ibid., slide 177.

<sup>139</sup> Ibid., slide 210.

<sup>140</sup> John R. Potter, "Challenges of Seeing Underwater—A Vision for Tomorrow," Acoustic Research Laboratory, Electrical Engineering Department and Tropical Marine Science Institute, National University of Singapore, <http://arl.nus.edu.sg>.

<sup>141</sup> Ibid.



14. Remotely Operated Mobile Ambient Noise Imaging System (ROMANIS), an array used as a passive receiver that compliments the range and resolution of VHF active systems to image underwater objects up to a range of 1,000 meters(1 km) and that is completely covert able to operate against silent targets.<sup>142</sup>

### ***3.3.3.3 Subsurface Sensors***

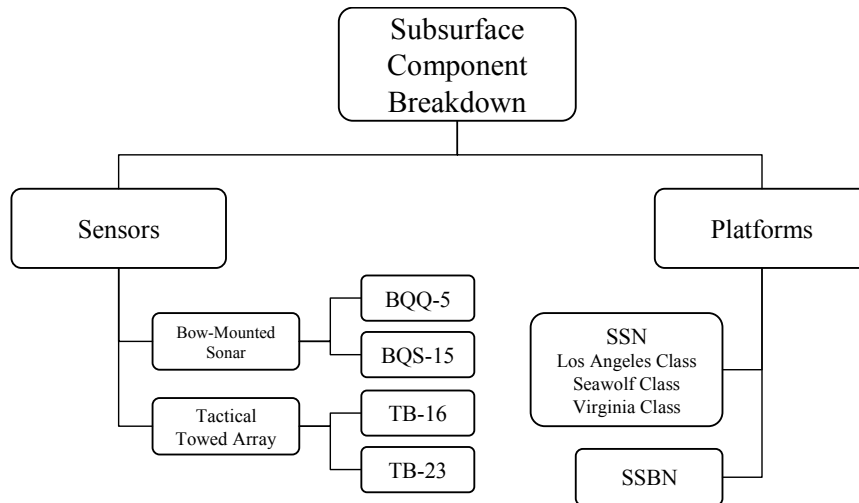
The advantage of military technology can rarely be held for long, and, as newer submarines become quieter, the effectiveness of purely passive sensors diminishes. As submarines move into shallow waters and, in particular, the littorals of 2025, the diminishing ability to detect threatening submarines amplifies. While submarine technology proliferates in the global market, the importance of signature management and detection will move to the forefront.

Currently, ships and submarines betray their presence in major and minor ways. Minor indications include unintentional electromagnetic emissions, chemical and bubble traces remaining in the wake, bioluminescence caused by the disturbance of minute organisms, and hydrodynamic pressure and surface wave patterns. However, compared to major indicators such as acoustic, magnetic, IR and radar signatures, these are relatively insignificant. In the year 2025, as signature management of acoustic and magnetic emissions improves and reductions in IR and radar occur, these lesser signatures will gain in importance as a secondary means of confirming the presence of a target.

The ASW subsurface components are listed in Figure 9 in the Needs Analysis section, and are repeated in Figure 64 in order to help illustrate the different sensors in use today.

---

<sup>142</sup> Ibid.



**Figure 64: Subsurface Component Breakdown**

As with the air and surface components, subsurface components are also broken down by platform as well as by sensors. However, Figure 64 contains only the mobile sensors (sensors found on submarines) and does not refer to the static sensors at all. Due to the limited number of classes of submarines in inventory today, every subsurface platform carries the same acoustic sensors, although some slight variations may exist between the version, upgrade, or original install found on each submarine.

In addition to Figure 64 detailing the mobile sensors, the following list specifies more accurately what sensors exist on submarines today:

<u>Nomenclature</u>	<u>Sensor Name</u>
BQQ-5	Bow-mounted sonar
BQG-5	Flank array
TB-16	Fat line towed array
TB-23	Thin line towed array
TB-29	COTS version of a thin line towed array
LWAA	Large wide aperture array
BPS-15	Navigational radar
BPS-16	Navigational radar
BRD-7	Intercept direction finding system
WLR-8	ESM Surveillance receiver
WLR-10	Threat warning system

Table 3 specifies on which platform each of the above sensors operates on:

	Active	Passive				Radar		EW					
	BQQ-5	BQG-5	TB-23	TB-16	TB-29	BPS-15	BPS-16	BRD-7	WLR-8	WLR-10	BLD-1	BLQ-10	LWAA
Los Angeles	X	X	X	X		X		X	X	X			
Seawolf	X			X	X		X				X		X
Virginia				X	X		X					X	

**Table 3: Platform and Sensor Matching**

3.3.3.3.1 ACOUSTIC DETECTION. Submarines emit high levels of underwater radiated noise that can be detected and tracked by passive sonar, possibly hundreds of miles away in the case of towed array sonar. Vessels, which strongly reflect incident sound waves, are easily detected by active sonar systems. Not only does a high level of radiated noise make a submarine far more susceptible to detection, it also inhibits that vessel's ability to operate its own acoustic sensors. By way of comparison, the SSN cannot shut down its reactor plant completely, so it will always emit some noise, whereas the SSK can shut down for a "silent routine" and, depending on the depth of the water, can lie and wait on the bottom. Underwater acoustic radiation, therefore, is still the primary means by which submarines betray their presence when they are submerged. Propellers and hulls create cavitations and broadband noise, while various internal pumps, generators, and diesel engines produce distinctive sounds at specific frequencies and amplitudes that can both aid and hamper detection. So sophisticated are modern detection methods that, in many instances, not only can the hunter classify a target as a specific class of ship, but even the individual ship within a class can be positively identified from its very own distinctive sound signature.

Current ASW sensors, from an underwater perspective, can be categorized as acoustic, of which active or passive detection becomes the distinguishing facet. What follows are two examples of current US underwater detection sensors and specific examples of their employment as ASW detection methods.

3.3.3.3.2 TOWED ARRAYS. Active towed arrays are now deployed in an effort to overcome the increasing use of stealth technology in submarine design that is making it very difficult to carry out initial detection of a target. The towed array has many advantages over the hull-mounted system in that it is deployed a considerable distance behind the ship and is thus not affected by any noise emanating

from the towing vessel. Towed arrays also achieve very long detection ranges by operating at very low frequencies where propagation losses are lower, enabling the low-frequency sound emanating from propeller cavitations and machinery of a hostile boat to be detected. The towed array does, however, suffer from a number of disadvantages including: being unable to determine the range of a contact (when operating in passive mode); ambiguity in bearing; directional uncertainty because of sideways movement of the array and the towing cable; flexing of the hydrophone array; and a number of other physical factors. These factors have been the subject of intensive research and development in recent years and have now been largely overcome. A further important factor to be considered in towed arrays is flow noise. This affects the hydrophones in the array as pressure fluctuations. Flow noise on an array is created in two ways:

- Vibrations in the array or cable strumming resulting from vortex shedding and vibration of the tail caused by the instability of the wake
- Turbulence-induced noise on the hydrophones resulting from the turbulent boundary layer around the wall of the cable

Vibrations are, to a degree, damped by vibration isolation modules mounted in the array. In addition, a large winch and handling gear is required to deploy the array. This is not a major problem on surface ships (except from a weight point of view), but is impractical in all but the larger classes of submarines.

An example of the US employment of the towed array is the BQQ-5, first produced in 1973. The BQQ-5D, found on the Los Angeles SSN, uses a TB-16 array and utilizes some of the technology common to the BSY-1 system, and has been operational since 1988. The BQQ-5E went into production 1994 using a new thin-line towed array (TB-29) for passive ranging that integrates with the LF bow spherical array and is operational in two variants (BQQ-5D and BQQ-5E) onboard Los Angeles-class submarines. The BQQ-5D is equipped on the Seawolf class and incorporates three flank arrays on either side. Frequency ranges of interest stretch from a few Hertz (Hz) for long-range, passive detection through a few kilohertz (kHz) for medium-range, active detection.

3.3.3.3.3 STATIC SYSTEMS. The large static systems moored on the ocean bed have been operated mainly by the US and Russia, while a

number of other countries installed less sophisticated systems, specifically to protect vulnerable areas in the littoral region.

In the past, static systems tended to be used in the most strategically important and sensitive areas and, in particular, at choke points. These are areas that are limited in width by land masses, but which serve as entry and exit lanes for submarines and in particular the strategic missile submarines. Attack submarines also patrol these areas to detect hostile submarines and neutralize them. There are many advantages to deploying passive, bottom-laid, static systems: they are inherently quiet, have little size restrictions, and can be laid in depths that mobile systems may not be able to reach.

Until the end of the Cold War, the SOSUS acted as the “linchpin” in the daily surveillance of the Soviet Fleet. SOSUS operated with SURTASS and T-AGOS and other inputs to comprise the larger-scale IUSS. Data processed from the arrays was relayed from shore stations and sent to aircraft, ships, and submarines for action. In optimum circumstances, detection and localization ranges from two or more arrays resulted in a circular error probable (CEP) of 8 NM to 45 NM.

3.3.3.3.4 NEAR- AND FAR-TERM DEVELOPMENTS. All of the developmental programs listed below were extracted from the Program Executive Office’s *Acquisition Opportunities for Early ASW Improvement: CNO ASW Offsite* presentation. Additional sources were researched in order to provide a more in-depth analysis of each sensor.

1. RAP VLA, comprises a subsurface ship deployed vertical line array to deep water for passive detection, localization, and tracking of quiet submarines using reliable acoustic path energy.<sup>143</sup>
2. LVAA, a rapidly deployed high gain volumetric sensor for passive and active detection, localization, and tracking of quiet submarines in a shallow water or deep surface duct environment. This sensor uses in-buoy data compression, ADAR data link, tactical platform

---

<sup>143</sup> Program Executive Office Integrated Warfare System, “Acquisition Opportunities for Early ASW Improvement,” CNO ASW Offsite PowerPoint presentation, 8 March 2005, slide 174.

detection/classification processing and will have the ability for satellite link in the future.<sup>144</sup>

3. Near Term Multi-Line Towed Array (NTMLTA), a sensor system comprised of three lines which together form significantly improved acoustic apertures, increased frequency coverage, and enhanced spatial resolution.<sup>145</sup>
4. Lightweight Broadband Variable Depth Sonar (LBVDS), designed as an alternative payload to the remote mine-hunting vehicle (RMV) Sea Talon, the LBVDS uses broadband acoustics to help distinguish difficult targets, i.e., diesel electric submarines, from environmental or background clutter. It combines the “extended stand-off detection range with the use of a coherent broadband projector in place of that system’s explosively generated signals.”<sup>146</sup>

### **3.3.4 PDT Alternatives Generation**

The PDT developed alternatives to answer each defined objective of the PDT’s subfunctions. Both realistic and nonrealistic alternatives were considered. PORs in similar areas were considered to give the team ideas about future technologies. The following alternatives were generated through brainstorming and are grouped according to the PDT’s three subfunctions of Maneuver, Deter, and Engage:

#### ***3.3.4.1 Maneuver***

- Objective: Maximize Operating Time
  - Alternative 1: Glider Concept
    - Use of change of buoyancy to ascend or descend in the water
    - Use of glider technology to travel long distances at low energy

---

<sup>144</sup> Ibid., slide 177.

<sup>145</sup> Ibid., slide 241.

<sup>146</sup> Mark Hewish, *No Hiding Place: Undersea Networks Help Flush Out Littoral Targets*, Jane’s International Defense Review, 14 May 2004, <http://www4.janes.com/K2/>, (accessed 8 November 2005).

- Alternative 2: Solar Power
  - Deploy solar panel at the water's surface
- Alternative 3: Wave Action Power Generation
  - Use of ocean current/waves to produce electricity using Faraday's Law
- Alternative 4: In Op-Area Recharging Station
  - Oscillates from surface to bottom by buoyancy
  - Connects with roaming UUVs and gliders
- Alternative 5: Nuclear or High-Energy Density, Stationary Recharging Station
  - Bottomed
  - Deployed from aircraft
  - Retrievable when queried
- Alternative 6: Sleep Modes
  - Use of sleep modes on all sensors
  - Wake on query or passive detection
- Alternative 7: Passive Bottomed Sensors
  - Communicate via deployed buoys
- Alternative 8: Recharging/Maintenance TSSE Ship/Submarine
  - Recovery and Redeployment Platform
- Alternative 9: Attach and Trail
  - Attach to enemy submarine then deploy tether to tow UUV
- Objective: Maximize Speed of Travel
  - Alternative 1: Rocket Propulsion
  - Alternative 2: Airborne Sensor Platforms
  - Alternative 3: Energy Burst Ability
    - Platform capable of short, fast, high-energy bursts
  - Alternative 4: Attach and Trail
    - Attach tether to enemy submarine that will tow UUV

#### **3.3.4.2 Deter**

- Objective: Maximize Enemy Defensive Maneuvers (deter enemy from taking offensive posture)
  - Alternative 1: Platforms that Ping Active (overt)
  - Alternative 2: Installing Trackers on Enemy Submarines
  - Alternative 3: Underwater Energy Pulse Deployed from Airborne Platform
    - Damage equipment
    - Injure personnel
  - Alternative 4: Prepositioned Explosion
  - Alternative 5: Propeller Mesh Disabler
  - Alternative 6: Constant Noise in Water (all blind)
  - Alternative 7: Psychological Operations
    - Radio broadcasts
    - Underwater broadcasts detectable by submarine sonar
  - Alternative 8: Deception
    - Propagation of false engine noises, etc., to deceive enemy platforms

#### **3.3.4.3 Engage**

- Objective: Maximize Mission Kills
  - Alternative 1: Torpedoes
    - Short Range
    - Long Range
  - Alternative 2: Depth Charges
    - Air-dropped
    - Ship-deployed
    - UUV-integrated
  - Alternative 3: Stationary Anchored Weapon
    - Activated by other comms
  - Alternative 4: Harbor Mines



- Create a mine field within or at the entrance/exit of enemy harbor.

Objective-specific alternatives are summarized in Table 4.

OBJECTIVES				
ALTERNATIVES	Maximize Operating Time	Maximize Speed of Travel	Maximize Enemy Defensive Maneuvers	Maximize Mission Kills
	Glider concept	Rocket propulsion	Platforms that ping active (overt)	Torpedoes
	Solar power	Airborne platforms	Installing trackers on enemy submarines	Depth charges
	Wave action power gen	Variable pitch propellers	Underwater energy pulse deployed from airborne platform	Stationary anchored weapon
	In op-area recharging station	Energy burst ability	Prepositioned explosion	Harbor-delivered mines
	Nuclear or high-energy density, stationary recharging station	Attach and trail	Propeller mesh disabler	
	Sleep modes		Constant noise in water (all blind)	
	Passive bottomed sensors		Psychological operations	
	Communicate via deployed buoys		Deception	
	Recharging/maintenance TSSE ship/submarine			
Attach and trail				

**Table 4: Objectives and their Respective Alternatives**

The functions and associated objectives of the PDT were either dissolved for the purpose of this study or transferred to the Prosecution and/or Deployment Teams for further research and study. Much of the insight and knowledge gained through the initial research was utilized in prosecution modeling. A significant amount of this information provided valuable, insightful, and research-based inputs for the Naval Simulation System (NSS) that SEA-8 used to simulate the four distinct alternatives generated.

### 3.3.5 ALTERNATIVE ARCHITECTURES

#### 3.3.5.1 Alternative 1: Tripwire

3.3.5.1.1 DESCRIPTION. The tripwire alternative uses a combination of UUVs and Advanced Seaweb-based sensor components capable of assessing the oceanographic environment, while simultaneously searching, detecting, and tracking enemy submarines throughout the AO. The Advanced Seaweb sensor components work in conjunction with the UUVs to create a complete underwater sensor network.

The initial network will be focused around the 10 NM x 10 NM water space surrounding the enemy port facility. Any COI that is detected by an Advanced Seaweb sensor or a UUV during the prosecution phase will be communicated through the underwater network and to the GIG. The COI will simultaneously hand off

the information to a UUV for the purposes of tracking and classification. This underwater sensor network will generate a thorough picture of the AO for the ASWC.

3.3.5.1.2 ASSETS. Fifty Seaweb-based sensors and 5 UUVs are air-dropped per harbor.

3.3.5.1.3 DEPLOYMENT. Deploying the UUVs and sensors by air from safe distances provides an exceptional amount of secrecy for the UUVs' and sensors' operations. UUVs are deployed similar to the Joint Standoff Weapon (JSOW). They will be low-observable glide vehicles that can be employed at significant standoff ranges. In addition to deployment of off-board sensors, SSNs provide organic sensor capabilities furthering the quality of this alternative. Once the UUVs and the sensors are inserted, a self-forming and self-healing sensor grid will begin to communicate data. The sensor grid implemented within the first 24 hours will be focused in and around the enemy port facilities.

3.3.5.1.4 PROSECUTION. The sensor grid will create a self-forming network that will simultaneously search the battle space while transmitting contact information to the command network. COIs can be further investigated by medium and light UUVs. Medium UUVs will be used as repeaters to bridge communications between the network and OTH command assets. Here it is envisioned that the underwater network will be able to communicate between nodes that are spaced by hundreds of yards. The medium UUVs will float at the surface and transmit information that is being broadcast underwater to above water receivers (or via SATCOM). These inconspicuous UUVs could be vectored in on identified enemy submarines and used for enhancing the tracking capability of the network.

3.3.5.1.5 DEFEAT. Information coupled with knowledge of the location and track of enemy submarines will allow friendly forces to avoid threatening situations. This in and of itself serves to prevent the enemy from being able to effectively operate against our forces. Increase friendly offensive operation would include using UUVs to "drive" enemy submarines away from friendly forces via active acoustics. If it becomes necessary to sink or disable enemy submarines, SSNs could be employed, or UUVs could detonate itself near the keel of the enemy submarines. As a final option, an advanced stand off weapon could be employed.

3.3.5.1.6 COMMAND. C2 of assets utilized throughout this alternative will require a robust and flexible network of nodes for communication and targeting. This network must be capable of transmitting and receiving critical data to nodes located aboard repeater UUVs. Networking features must include the ability to transfer C2 of deployed sensor assets from one controlling asset to another via SATCOM or similar network.

### ***3.3.5.2 Alternative 2: Sea TENTACLE, TSSE***

3.3.5.2.1 DESCRIPTION. The Sea Tentacle alternative combines all assets of the Trip Wire Alternative plus a specially designed TSSE ship accompanied by an MH-60 detachment in order to successfully conduct ASW in the littorals. Once assets are inserted into the AO, the effective utilization of these assets will be paramount to achieving required sensor coverage. UUV assets will provide multiple capabilities while on station including operating submerged for extended periods collecting, receiving and transmitting data collected by its sensors.

3.3.5.2.2 ASSETS. Covering the AOR of a 100 NM x 200 NM box, Sea TENTACLE incorporates 3 Sea TENTACLE ships, 144 large vehicle UUVs, including 144 UUV sleds transported by the large vehicles that detach from the large vehicle to create a stationary bottom sensor, 864 light-weight UUVs that form the communications and “brains” of the sensors, and 2,304 man-portable UUVs deployed from the UUV sleds that spread out to form the sensor web.

3.3.5.2.3 DEPLOYMENT. To perform coverage of the AOR, a platform that carries a larger payload of assets must be used. The TSSE surface ship is a good candidate for this job. The TSSE ship design will be able to carry UUVs and Sea Predator drones with a large number of sensors. She will be able to deploy her UUVs from a far enough distance as to not face any enemy attack from the littorals. As mission needs dictate, the TSSE ship design can come in closer to recover and provide maintenance support of her UUVs.

3.3.5.2.4 PROSECUTION. The sensors to be delivered will be the same for both the Harbor Gate and AO. These sensors will be capable of remaining powered for at least 30 days. They do not have the ability to move from their

current position to a new position to fill any gaps in the Advanced Seaweb system, but the Advanced Seaweb System will remain stationary at anchor. Also, the Advanced Seaweb System will be capable of deploying a tethered communication buoy to the surface of the water to communicate enemy submarine detection to the ASWC.

3.3.5.2.5 DEFEAT. The TSSE design has the ability to not only deploy Advanced Seaweb Sensors and UUVs, but also, recover the UUVs for further deployment. The combination of stealth and rapidly deployable technology would leave an enemy submarine guessing where the knock out blow is coming from.

3.3.5.2.6 COMMAND. A robust underwater network will be required to share vast amounts of information. The network will be controlled remotely from a littoral ASW center and connected by surfaced network gateways and high altitude network relays where it will be interfaced with the littoral battlespace tactical network. The composition of information to support this alternative will be primarily digitized and will form the information necessary to convey area situational awareness and complete engagements. The network will be distributed throughout the OPAREA to widen the area situational awareness but will require a well constructed power infrastructure. The fusion of tactical data will be made available on an operational and strategic level via Global Information Grid (GIG) operations to effectively reach back for any additional guidance and information.

### ***3.3.5.3 Alternative 3: War of Machines***

3.3.5.3.1 DESCRIPTION. In the War of Machines alternative, a combination of sensors, specific to each type of platform, will be utilized to develop a complete and detailed surface and subsurface picture of the AOR. This alternative deploys a series of UUVs and recharging stations designed to provide a real time tactical assessment in the AO.

The combination of UUVs and their recharging stations allows for extended presence without personnel risks. This alternative provides for a robust and overlapping sensor suite capable of detecting any enemy submarine whether it is operating underwater or surfaced.

Once a submarine has been detected, assets in this alternative will be capable of accurately tracking an enemy submarine while simultaneously coordinating with other unmanned platforms relaying detection and tracking information to ensure a constant track is maintained. Because of the extended tracking capability, this alternative will also be able to determine with a high level of confidence that the tracked contact is indeed an enemy submarine (higher classification confidence).

3.3.5.3.2 ASSETS. At any given point in time, only 40 operational UUVs will be required to affectively cover the AO. If the UUVs are recovered and maintained, only 60 UUVs along with 12 recharging stations will be required to affectively cover the AO. If the ASWC decides not to recover the UUVs for maintenance, then 160 UUVs and 12 recharging stations will be required to cover the AO. The reliability of the UUV will be discussed in more detail in Section 3.5 Reliability and Sustainment..

3.3.5.3.3 DEPLOYMENT. This alternative provides a heavily autonomous solution by minimizing manned systems in the AO. The use of UUVs and their associated ASW sensors components will serve as the primary assets to be deployed into the AO to achieve sensor coverage.

Air deployment options are primarily through carrier and land-based aircraft:

- JSF and the F/A-18E/F provide the ability to rapidly deploy UUVs into high probable areas of enemy submarines.
- B-52s are capable to large payloads of UUVs and greater range than carrier based aircraft.
- The stealthy B-2s are able to enter riskier areas and deliver their payload of UUVs.
- P-8 (MMA) could provide the ability to deploy their UUVs, loiter in the AO, and process any data for the ASWC.
- Additional air deployment options are VLS and rail launch.

The use of surface ship assets loitering outside the AO such as DD(X), CGX, and the TSSE ship will provide great lift and logistical capabilities for the deployment and subsequent support of UUVs

3.3.5.3.4 PROSECUTION. In the War of Machines alternative, a combination of sensors will be utilized to develop a complete and detailed subsurface picture of the AO. First, this alternative will deploy sensors designed to provide a real time environmental assessment of both atmospheric and oceanographic conditions in the AO.

Second, this alternative will deploy UUVs as well as a sensor system to the AO. The combination of these UUVs along with the sensor system will conduct coordinated Littoral ASW search operations in the AO.

Third, these search operations will utilize a robust and overlapping sensor suite capable of detecting any surfaced or subsurface enemy submarine. Additionally, this sensor suite will have the ability to assess the effectiveness of any offensive engagements conducted in the AO.

Fourth, once a submarine has been detected this alternative will be capable of accurately tracking an enemy submarine while simultaneously coordinating with other UUVs to relay detection and tracking information to other US assets who can assist with tracking the enemy submarine.

Finally, this alternative will have the capability to classify or determine a level of confidence that the tracked contact is indeed an enemy submarine.

3.3.5.3.5 DEFEAT. Considering a combination of alternatives for the Defeat objective, SEA-8 will use the following in the War of Machines alternative. Battery-powered UUVs will use glider technology to extend their range and time in water. Wave-action and TSSE platforms will be used to recharge operating UUVs.

UUVs will be capable of using active sonar for search and deterrence. Short sprint capability will allow the placement of a tag on enemy submarines for further tracking. If engagement is necessary, it will be conducted by UUVs capable of homing in on enemy submarines and preplaced tags.

3.3.5.3.6 COMMAND. For an entirely unmanned force pack that operates with partial artificial intelligence or swarming tactics and techniques, command focus will reside on sharing necessary information between platforms to be processed and then shared on the littoral battlespace tactical network. This alternative

will consist of a centralized underwater network that will be used to share timely information when an underwater unit comes within range of the underwater network or is signaled to share information. The battlespace tactical network will operate autonomously and be instantaneously reconfigurable. Information that is passed between units will be operational controlling in nature and induce collaborative action based on requests from commanders within the littoral ASW center. To facilitate communication between units a complex messaging system will be utilized and be unique to both underwater and above water units. Underwater messaging will consist primarily of succinct action direction information to be distributed across the force pack. Above water messaging will be made up of more detailed instruction and information that will be processed and acted on. It is imperative that controlling surface units are capable of processing C2 information and delivering accurately filtered data to underwater units for action. The fusion of tactical data will be made available on an operational and strategic level via GIG operations to effectively reach back for any additional guidance and information.

#### ***3.3.5.4 Alternative 4: LAG***

3.3.5.4.1 DESCRIPTION. The LAG, when operating in the AO, will conduct coordinated littoral ASW operations with all available assets and sensors. These operations will be driven largely by the presence of enemy submarines, both organic and inorganic to the LAG, and the endurance and capabilities of onboard unmanned assets to extend the reach of friendly forces as far inside the AO as possible while holding the enemy at risk. Assets in this alternative rely on high speed, maneuverability, and low detectable signature to attack and withdrawal in the shortest amount of time.

While this alternative resembles current ASW operations conducted by a SAG, the new surface platforms will have a more robust ASW capability and will be more aptly suited for the task in the littorals.

3.3.5.4.2 ASSETS. LAG Composition: 2 SSN (on station), plus 1 DD(X) including organic assets and 3 LCS (ASW) including organic assets.

3.3.5.4.3 DEPLOYMENT. The LAG will be formed upon direction of the ASWC and be comprised of sub-surface, surface, and air assets required and available within theater. Forces may be drawn on from forward-deployed CSGs and ESGs, transiting units, pre-positioned assets and units presently in port. Upon the order to deploy forces, the ASWC will designate a LAG Commander and chop units from area forces to his/her TACON as available.

The CSG component will draw available supplies from the CSG as needed and sprint ahead of the group at best speed to the AO in accordance with ASWC order of battle. Forces will need to rendezvous with T-AOE to resupply if the operation lasts more than allowable fuel limits permit. The ESG component will detach and make best speed for the AO, making fuel stops as required.

LAG platforms will be capable of deploying an underwater sensor network as required. It is assumed that these platforms will provide greater lift capabilities than rapidly deployable aircraft. The deployment of an underwater sensor network will reinforce the rapidly deployed sensors already inserted into the AO via air and subsurface assets.

3.3.5.4.4 PROSECUTION. The order of battle will largely be determined by the political situation at the time forces arrive in theater. The LAG, when operating in the AOR, will conduct coordinated littoral ASW operations with all available assets and sensors. These operations will be driven largely by submarines both organic and inorganic to the LAG and the endurance and capabilities of unmanned assets to extend the reach of friendly forces as far inside the AOR as possible, while holding the enemy at risk.

If, during the coordinated littoral ASW operations, a LAG sensor detects an enemy submarine (CERTSUB) and the ASWC issues a kill order based on the immediate threat posed by the enemy submarine, a formation of LCS (ASW) could proceed into the AOR to attack and kill the submarine if they were best suited to the task. LCS would rely on high speed, maneuverability, and low detectable signature to attack and withdrawal in the shortest amount of time. A DD(X) would be assigned to provide air and surface defense of the LCS as well as combat search and rescue in the event one, or both, of the LCSs are lost.



3.3.5.4.5 DEFEAT. Offensive engagement will be completed by manned platforms. LCS will be equipped with Fire Scout UAV for OTH targeting as well as UUVs for ASW. If a submarine is located, LCS could engage directly with UUVs or with own ship torpedoes, and ASROC. DD(X) also possesses ASW capability, but its primary role is to support and defend LCS in the prosecution of its mission.

3.3.5.4.6 COMMAND. Command resides with the ASWC for overall prosecution of the ASW campaign. The ASWC will appoint a LAG Commander who will maintain C2 of forces assigned ASW. Directional communications must not be radiated in the direction of enemy forces. The LAG should maximize the use of LOS SATCOM radiated as near zenith as possible to limit detection. These requirements take on less importance with regard to unmanned systems and may be of no importance to expendable sensors.

C2 information sharing and fusion will be achieved through the seamless integration of three command architectures:

- a communication network
- a tactical data network
- and an ISR exchange network

The operating premise for each network is to tie together distributed units and their respective sensor information to enhance situational awareness above and below the sea. Enhancing situational awareness will expedite the prosecution process and ultimately reduce the kill chain. Each unit will accordingly be fitted with a data distribution system that will interface with internal systems and interoperate with networked units to attain a fusion of tactical data. The fusion of tactical data will be made available on an operational and strategic level via GIG operations to effectively reach back for any additional guidance and information.

### ***3.3.5.5 Alternative 5: Floating Sensors***

3.3.5.5.1 DESCRIPTION. Alternative 5 is comprised of UUVs, drifting sensors, and SSNs this alternative creates an information funnel, which provides the ASWC with knowledge of the battlespace. Each asset participates into an underwater communication system which is linked to the GIG.

3.3.5.5.2 ASSETS. If a light sensor grid is chosen by the ASWC, 25 sensors would be required for each 10 NM x 10 NM box. However, if a heavy sensor grid is chosen, 41 floating sensors would be required for each 10 NM x 10 NM box.

3.3.5.5.3 DEPLOYMENT. Effective deployment will require speed and stealth to fully exploit the inherent potential of UUVs and the floating sensors. Air and subsurface deployment options provide the best resolution to achieving these critical attributes. Land-based aircraft, such as B-52s and B-2s, are ideal for the deployment of the sensor fields. These aircraft provide extended range and ample payload for deployment and subsequent reseeding of the sensor field. SSNs do not provide the payload of a B-52s, but SSNs do provide the ability to recover UUVs when needed. Also, SSNs can carry UUVs and floating sensors closer to the enemy's shores and deploy UUVs and floating sensors with more accuracy.

3.3.5.5.4 PROSECUTION. Once assets have been inserted into the AO, the effective utilization of these assets will be paramount to achieving required sensor coverage. Capabilities of the SSNs onboard sensors will determine approximate number of platforms and their distribution about the battlespace.

3.3.5.5.5 DEFEAT. Floating Sensors and UUVs will provide targeting data to the system by communicating to SSNs. The SSNs will find the enemy submarine based on previous and updated data, gain a fix on the enemy submarines position, and finally finish the enemy submarine off. The capability to track and trail enemy assets will be possible with UUVs, but only the SSN is capable of engaging the enemy submarine.

3.3.5.5.6 COMMAND. C2 of assets utilized throughout this alternative will require a flexible network of nodes for communication and targeting. This network must be capable of transmitting and receiving critical data to nodes located aboard UUV and Floating Sensor assets. Command will reside with the ASWC who will conduct C2 from the littoral ASW center. The force will employ the use of a single battlespace tactical network that will be interfaced by each of the ASW units. Underwater ASW units will communicate via an underwater network. Frequently updating situational awareness and receiving tactical instructions will improve the effectiveness of a common

undersea operating picture through collaborative processing that will meld current information with previous underwater surveillance data and cooperative active participant surveillance tactical data. Communication architectures for underwater units will be enhanced through advanced communication circuits and a digital UUV communication messaging system. This alternative's message sharing system will have a larger capacity to transfer voice, tactical information, and ISR information. The fusion of tactical data will be made available on an operational and strategic level via GIG operations to effectively reach back for any additional guidance and information.

### **3.4 MODELING AND ANALYSIS**

#### **3.4.1 Command Modeling and Analysis**

Modeling for the littoral USW C4ISR system was divided between an Excel-based model for use in modeling undersea acoustic data transfer and an EXTEND-based model for modeling above sea data transfer. The two models were constructed in an effort to offer insight into system performance and provide direction for tactical and operational decision-making between various alternatives. Additionally, the two models offered insight into constraints on system performance and utility. The models support previous needs and objectives analysis by quantifying predicted performance that can be compared to the identified metrics and key requirements previously detailed in the Command Team's SEDP analysis. Estimated sensor detection ranges, system power constraints, and notional nodal spacing, focused model inputs to produce resultant model outputs that are listed in detail below.

##### ***3.4.1.1 Undersea Acoustic Data Transfer Model***

The identification of limiting factors are a key element in the analysis of any complex system. In the case of a wireless undersea communications system, the limiting factor became the transfer of critical data between undersea sensor nodes to form the "thinking field" of networked sensors, weapons, and platforms. Effectively transferring data undersea using acoustic modems limits both the distance between connected nodes and the data transfer rate necessary to achieve desired performance. The intent of developing an undersea acoustic data transfer model was to test alternatives

generated previously in the SEDP and to provide insight for the next iteration of wireless information distribution alternatives to obtain a more robust undersea sensor network. The model met these objectives. Additionally, the model offered insights into specific characteristics that were not necessarily intended to be modeled, but were discovered in the analysis of modeling data (i.e., appropriate carrier frequencies, bandwidth required, and the impact of varying data packet size).

To construct the Excel-based undersea acoustic data transfer model, desired model outputs were obtained to identify the most appropriate approach to modeling. The Command Team examined many modeling alternatives based on expert interviews, previous analysis, and key requirements, and identified the *distances* (range) between undersea sensors and *data rate* (capacity) as the critical model outputs. Since previous analysis conducted in the Feasibility Screening portion of the SEDP identified Tele-Sonar as the most promising method of undersea communications, acoustic radiation was modeled using a modified version of the conventional sonar equation. By applying the sonar equation, a *signal to noise ratio* (SNR) was able to be determined by adding *carrier frequency*, *transmission power*, *ambient noise* and varying *range* within the *transmission loss quantity*. Below is the conventional sonar equation that was used for this model.<sup>147</sup>

$$SNR = PSL - TL - AN + DI_{rcvr} + DI_{xtr}$$

**Equation 2: Signal to Noise Ratio**

where

*SNR* is Signal to Noise Ratio at the receiver

*PSL* is Pressure Spectrum Level of transmitting platform

*TL* is Transmission Loss of the medium

*AN* is Ambient Noise of the environment

*DI* is Directivity Index of the receiver and transmitter.

Each of the terms is referenced in decibels (dB). For the purposes of this model, the *DI* terms are zero, because the transmitters and receivers are omnidirectional. The remaining terms are a function of acoustic frequency, *f*, since system and channel variations fluctuate across the operating spectral band.

---

<sup>147</sup> A.D. Waite, (1998), SONAR for Practicing Engineers, (Thompson Marconi Sonar Ltd., 1998).

The PSL of the transmitting platform for pure broadband is,

$$PSL = SL - 10 \bullet \log_{10}(W)$$

**Equation 3: Pressure Spectrum Level**

where the Signal Loss (SL) term used is

$$SL = 10 \bullet \log(PWRtx) + 170.8$$

**Equation 4: Signal Loss Term**

and  $W$  is bandwidth, more commonly known as the width of the frequency band. For this model it is assumed that for broadband operations,  $W$  equals half of the carrier acoustic frequency.

$$W = .5 \bullet f$$

**Equation 5: Width of Frequency Band, or Bandwidth**

The Transmission Loss (TL) quantity is dependent on range and frequency. For distances less than the depth of the transmission medium,  $TL$  is often assumed to correspond to spherical spreading, and is calculated to be:

$$TL_{Spherical} = 20 \bullet \log_{10}(r)$$

**Equation 6: Transmission Loss as a Function of Spreading**

where  $r$  is range, in units of meters.

Acoustic propagation signals attenuate due to scattering and absorption. TL due to attenuation varies linearly with range, and is calculated by:<sup>148</sup>

$$TL_{atten} = \alpha r \times 10^{-3}$$

**Equation 7: Transmission Loss as a Function of Attenuation**

$$\alpha = \frac{0.11f^2}{1 + f^2} + \frac{44f^2}{4100 + f^2} + 3.0 \times 10^{-4}(f^2) + 3.3 \times 10^{-3},$$

**Equation 8: Attenuation Coefficient**

where  $r$  is range in meters,  $\alpha$  is the attenuation coefficient in dB/km, and  $f$  is frequency in KHz. Total TL can then be calculated by adding the spherical loss with the loss due to attenuation.

$$TL = TL_{Spherical} + TL_{atten}$$

**Equation 9: Total Transmission Loss**

---

<sup>148</sup> Robert Urick, (1996), *Principles of Undersea Sound 3<sup>rd</sup> Edition*, (McGraw-Hill, Inc.).

The TL terms introduce range- and frequency-based attenuation as an input.<sup>149</sup> By inserting ranges while keeping a frequency constant, a range value can be associated with a specific SNR when all other variables remain constant. The quality and reliability of the tactical data transferred is represented in the SNR term. Since this model was able to generate a wide range of SNRs based on range, frequency, transmission power, and AN, a SNR of 100 dB was discovered as the basis for overall system performance.

For the purposes of this modeling effort, multiple transmission powers, AN level, and carrier frequencies 10 kHz and 12 kHz were used to provide performance areas for trade space analysis. Based on notional power constraints of stand-alone undersea units and initial acoustic data transfer requirements, only two transmission power values were used for the sensitivity of this model—10 watts and 20 watts. Larger undersea acoustic systems could be equipped with more powerful transducers and transmitters capable of achieving a transmission power level greater than 20 watts. However, it was assumed by the Command Team that for this particular undersea communication system, it was not necessary for sensors units to transfer data greater than their detection range. It was also assumed that sensor units will be operating with a limited power supply sufficient for operations lasting several days. Differing transmission power between 10 watts and 20 watts also indicates a “cost benefit” statistic that was captured by the model.

AN quantities for the littorals were taken from Urick’s *Ambient Noise in the Sea*. Through his studies, Urick found that AN levels in the littorals ranged from 40 dB to 50 dB for frequencies above 1,000 Hz.<sup>150</sup> It is important to note that the frequencies used for this model, 10 kHz and 12 kHz, are affected more by wind noise in the littorals than by manmade shipping noise. To test Urick’s findings, Bass Strait AN levels were analyzed using the Personal Computer-based Interactive Multisensor Analysis Training (PC IMAT) model, a laptop computer based model used to produce acoustic predictions based on geographic location and time of year. PC IMAT predicted AN levels based on surface winds that were similar to Urick’s findings and the values

---

<sup>149</sup> Robert Urick, (1996), *Principles of Undersea Sound 3<sup>rd</sup> Edition*, (McGraw-Hill, Inc.).

<sup>150</sup> Ibid.

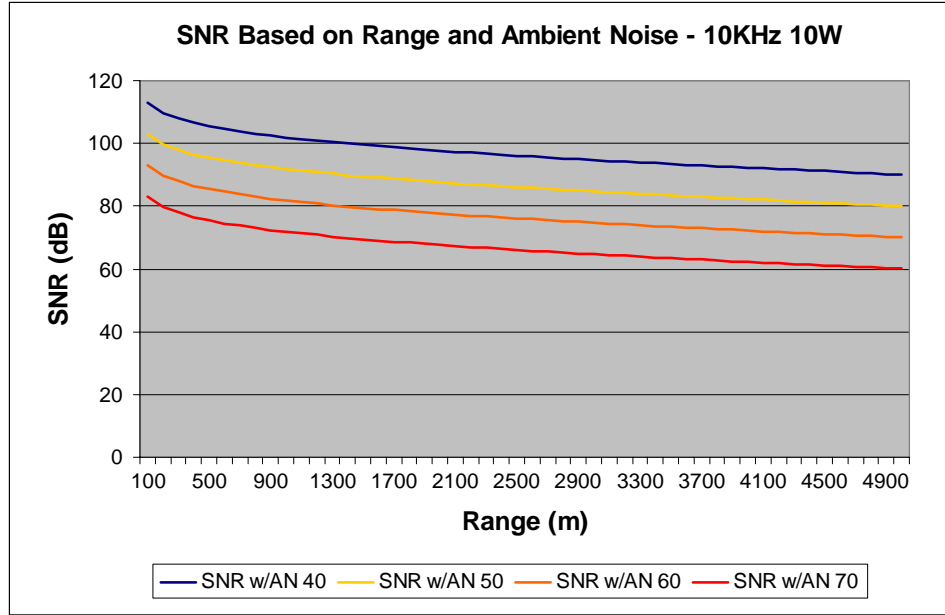
used for this model. Wind values used as inputs into PC IMAT were taken from the Australian National Weather Agency for Wilson's Promontory.

The result of this portion of the modeling effort shows that AN levels proved to have the greatest effect on transmission ranges. This acoustic data transfer model also investigated the effects on signal to noise ratios as AN is increased to 70 dB to show predicted performance in an extremely noise-filled environment.

As stated previously, carrier frequencies used for this model were 10 KHz and 12 kHz, and were chosen for this application based on the current performance of acoustic data transfer systems. Although frequency dependent attenuation is much greater at 10 kHz and 12 kHz when compared to 1 kHz and 5 kHz, there is more benefit in using higher frequencies because they lend themselves to the greater data rates required in an unfolding tactical environment, when multiple nodes are present to share bandwidth. Ranges provided by the model are affected by frequency attenuation proving that as frequency increases, transmission range decreases at specific SNRs and AN levels.

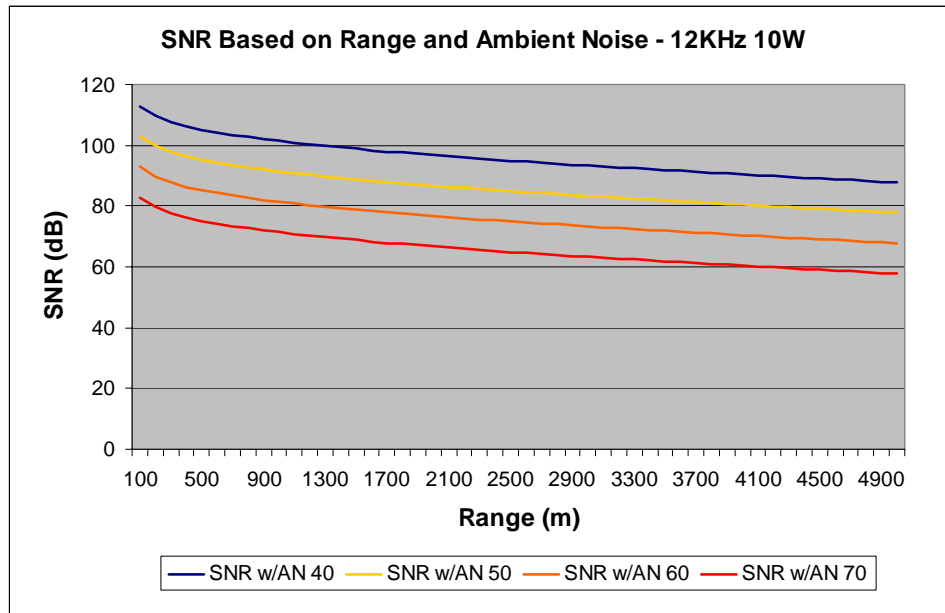
The following charts illustrate predicted system performance with respect to range based on frequency, transmission power, and AN. Figures 65 through 68 indicate system performance as SNR over range based on frequency, transmission power, and AN. Four levels of AN were used to identify system performance based on the amount of excess environment noise. As previously stated, the littoral areas of interest will typically generate AN levels between 40 dB and 50 dB.

As shown in Figure 65, a system that operates at 10 kHz with a peak transmission power of 10 watts can expect to transfer data with an SNR of 100 dB at 1,600 meters when 40 dB of AN is present. Since noise levels will typically exist between 40 dB and 50 dB, any range between 200 meters and 1,600 meters can be expected. Within the Bass Strait, average wind-generated AN levels centered on 42 dB, resulting in an expected undersea acoustic data transfer range of 1,200 meters.



**Figure 65: SNR Based on Range and AN – 10 kHz 10 W**

Attenuation based on frequency is evident in Figure 66. At 12 kHz, expected ranges decrease to 1,200 meters for 40 dB of AN and 200 meters for 50 dB of AN.



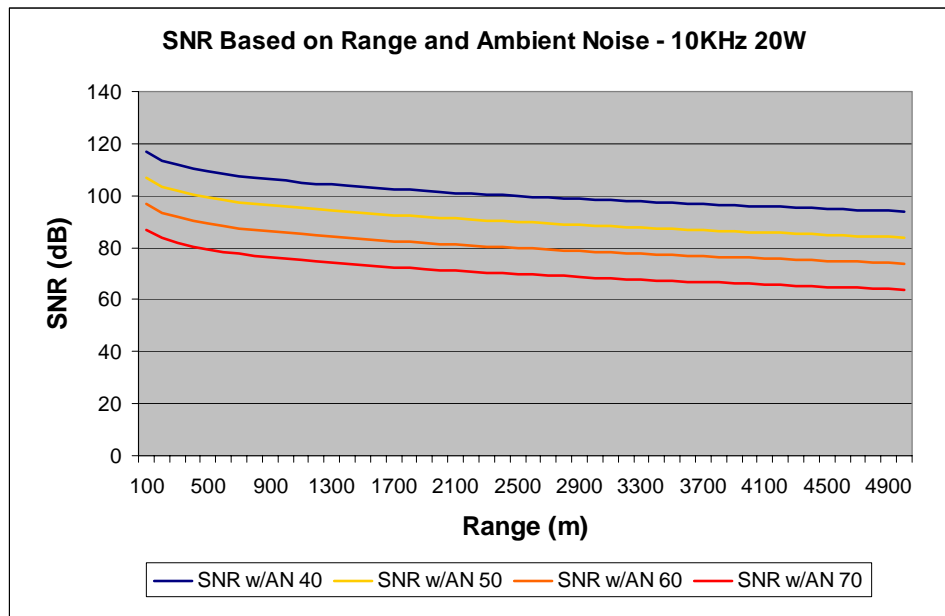
**Figure 66: SNR Based on Range and AN – 12 kHz 10 W**

Figure 67 illustrates the difference in system performances with respect to an increase in transmission power. A transmission peak power increase to 20 watts results



in a significant increase in transmission range at 10 kHz. At the acceptable 100 dB SNR, transmission ranges can be expected out to 2,600 meters at 40 dB of AN.

Likewise, with 50dB of AN, transmission ranges can be expected to 500 meters. Within the Bass Strait, average wind-generated AN levels are centered on 42 dB. Based on the these parameters, 10 kHz at 20 watts results in an expected undersea acoustic data transfer range of 2,200 meters. The increase in peak power and transmission range indicates a metric for follow-on “cost benefit” analysis. Further analysis on estimated power requirements for an undersea networked system of sensor units will be discussed in a later chapter.



**Figure 67: SNR Based on Range and AN – 10 kHz 20 W**

The final figure associated with this model (Figure 68) illustrates system performance at 12 kHz and 20 watts. As previously discussed, higher frequencies attenuate faster and result in decreased transmission range. Although, it is important to recognize the increase in transmission range based solely on the increase in transmission power. With 40 dB of AN transmission ranges can be expected out to 1,800 meters at 12 kHz and 20 watts of peak power. Additionally, when there is 50 dB of AN present, transmission ranges decrease to 400 meters at 12 kHz and 20 watts of peak power.

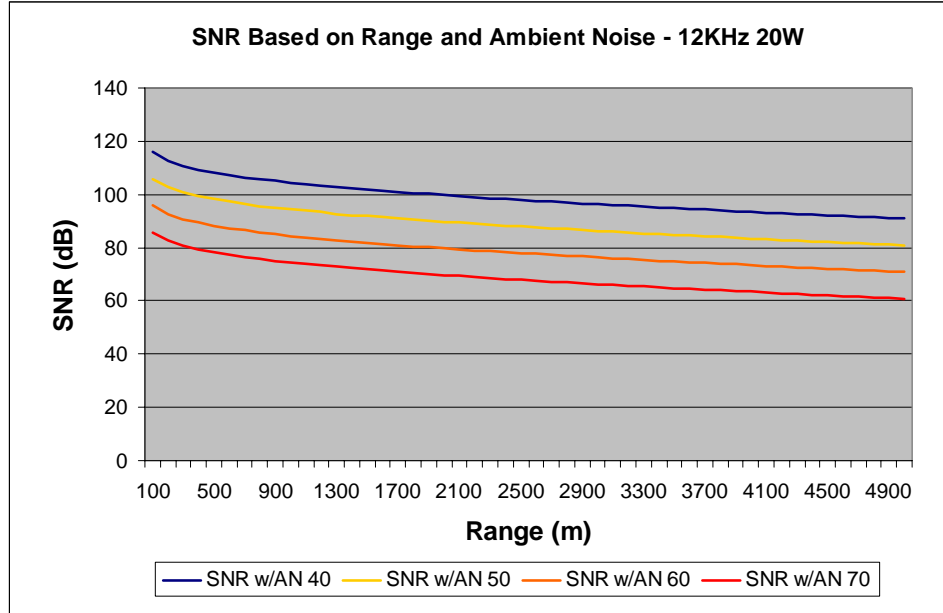


Figure 68: SNR Based on Range and AN – 12 kHz 20 W

Capacities based on the frequencies were investigated to supplement the data transfer model and provide insight as to what data rates could be expected. Initially the capacity equation<sup>151</sup>

$$C = W \cdot \log(1+SNR)$$

**Equation 10: Capacity Equation**

was used, but because of higher acceptable SNRs and digital technology, the term “log(1+SNR)” was replaced by a digitizer constant.

$$C = W \cdot Ndig$$

**Equation 11: Digitizer Constant**

For example, if an 8-bit digitizer is used, the capacity of a 10 kHz carrier signal would be 40 Kbps, which is calculated by multiplying  $W$ , the width of the band which is equal to half of the carrier ( $W = 0.5 \cdot f$ )—by the digitized capability. If a 16-bit digitizer is used, then the system capacity of a 10 kHz system would be 80 Kbps. It is important to note that as the number of nodes increases, the available bandwidth decreases by that factor of

<sup>151</sup> M.B. Porter, F.B. Jensen, N.G. Pace et al., (2002), High-Frequency Propagation for Acoustic Communications, *Impact of Littoral Environmental Variability on Acoustic Predictions and Sonar Performance*. Kluwer Academic Publishers, pp. 287-294.

nodes. When developing an undersea system of sensors using five nodes, the width of the band is divided into fifths, which reduces the capacity of each node by that factor.

The division of bandwidth is an important consideration when determining the amount of data that needs to be transferred or shared between nodes. This capacity equation offers the relationship between carrier frequency and bandwidth.

3.4.1.1.1 UNDERSEA ACOUSTIC DATA TRANSFER MODEL CONCLUSIONS. The following conclusions were based on the acoustic data transfer model. Environmental AN has the greatest effect on system performance. The model indicates that as frequency increases, transmission ranges decrease, and as transmission power increases, transmission ranges increase. At an acceptable SNR of 100 dB, transmission ranges vary from 1,200 meters to 2,200 meters depending on frequency and power at 42 dB of average AN. Additionally, when packet size is taken into account, broadband capacities at a 10 kHz carrier frequency and 8-bit digitizer constrain an undersea system by limiting the number of nodes that can make up one network. If 10 nodes were needed in a single network component, then the maximum data rate achievable would be 4,000 bps on that 10 kHz carrier frequency.

#### ***3.4.1.2 Above the Sea Data Transfer Model***

For an above the sea data transfer model, two air network architectures were initially analyzed: a centralized architecture and a decentralized architecture. The initial feasibility analysis for the two architectures identified that the decentralized architecture did not fall in line with the joint transformation vision. The analysis indicated that a decentralized system would require every platform to employ identical data distribution systems. Identical data distribution systems require the same control software and processing units within each participating platform. An identical system would not support open architecture requirements that have been set forth by the DOD Transformation Office. For that reason, this analysis only takes into account the performance of centralized network architecture.

The intent of developing an above the sea data transfer model was to provide insight for C2, intelligence, and tactical sensor information distribution. The model provides insight to the “speed of fusion” by using unit message generation rates

with bit sizes and receiver bit rate processing to obtain data latency associated within the system.

The above the sea data transfer model is an EXTEND-based model that was derived from the CSMA LAN example within EXTEND. The LAN example specifically uses an Ethernet routing logic that provides an excellent representation for processing multiple messages, rates, and packet sizes from multiple nodes. In order to accurately represent centralized network architecture, nodes that are present in the model are assigned varying bandwidth capacities of small (0.1Mb), medium (0.5Mb), and large (1.0Mb). Varying node bandwidth capacity, while holding input message sizes constant, will provide insight as to how data latency is produced as data flow is restricted due to limited capacities. The Common Operating Picture (COP) update messages sent from each node to the central node were also held constant in size but node transmissions were varied at a rate that is distributed uniformly between 0.2 seconds and 0.3 seconds. COP update messages that were distributed from the central node to all participant nodes were also varied to gain insight as to how large the update messages could be within the model before specific nodes became severely backlogged. To represent timely updates, the central node waits until four participant update messages are received before sending a large COP update. Unit bandwidth restrictions and limitations are represented by inducing an Ethernet-type processing delay before the message exits the node.

Data fusion is represented in the model by assuming that, as a message is exiting a node, it has been fused for operator or system action. The “speed of fusion” present in this model was determined by the delta formed between a centralized COP update message generation and the time at which that message was fused on a specific node. It is important to note that every message that is generated from the central node as a COP update message carries the same time stamp and is simultaneously distributed to all participant nodes. Ultimately, the transmission to fusion time delta that is associated with each node directly reflected respective participant node capacities and associated data latency.

Participating nodes that are represented include decision-making, relay, sensor, and multifunctional nodes. The architecture’s central node is a decision node capable of supporting participant message processing and generating COP messages.

Participants that act as decision nodes are equipped in this model with large capacities. Sensor nodes within the model are represented with small capacities and contribute small data packets to the central node. Sensor nodes are the best representation for the undersea to air network gateway. Although the undersea network gateway acts as a relay between tactical undersea and air networks, undersea sensor information is gathered collectively and then sent from the gateway as a sensor would transmit sensed information.

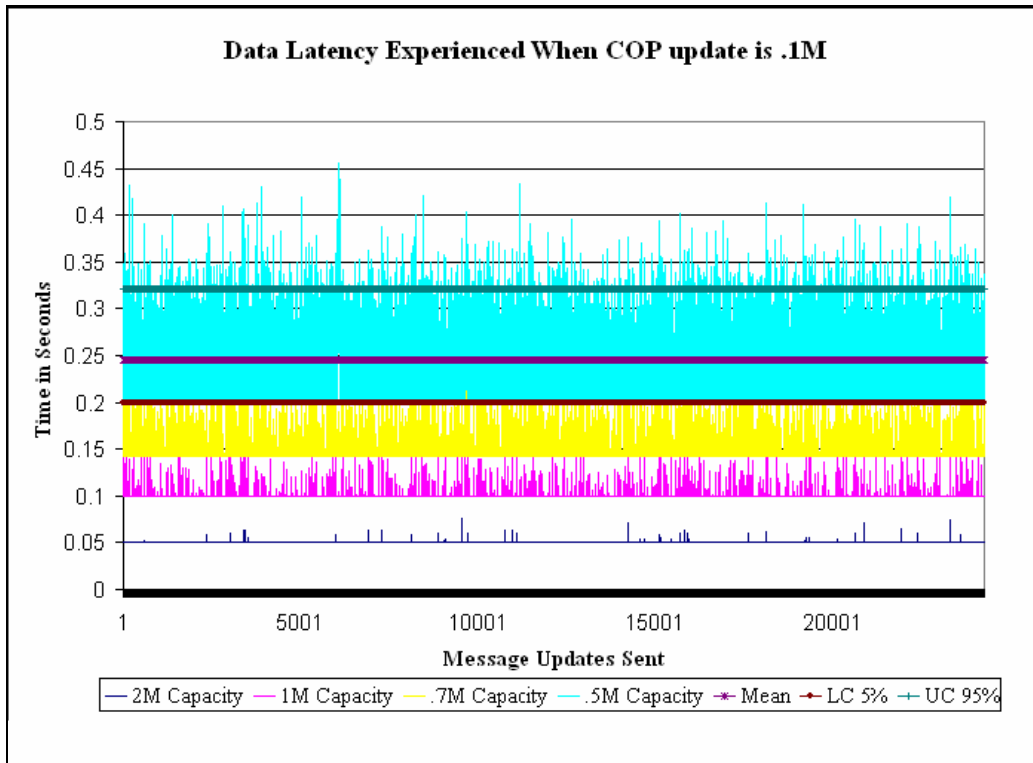
Relay nodes are modeled with both large and medium capacities to represent “reach back” capabilities and are combined with external battlespace nodes. Multifunctional nodes are represented by nodes that do not support large bandwidth capacities. The multifunctional node participants are most prevalent in all the overall project alternatives and represent a local control unmanned system that collects, processes, and distributes tactical information to the central node. Multifunctional nodes greatly contribute to overall tactical data latency and become bottlenecks in a data distribution system.

Message flow within the model represents tactical information that is generated and sent from multiple participants to the central node, where a COP update message is generated and distributed to all participants. The most crucial aspect in the model is the central node processing that represents combining multiple participant sensor information to form tactically cooperative track data. Messages that are fused at the central node form the updated COP update message. It is important to note that the central node waits until four participant messages are received before updating the operating picture. The purpose for combining four messages is to avoid a first in/first out situation, where messages are processed one at a time. Processing messages one at a time is not an accurate representation, since the COP generated would simply be one participant’s update and would not be of use to the original participant.

The following products were generated by the model and are used for providing insight as to how centralized network architectures perform under overall project parameters and participants. Additionally, the model generated applicable metrics that were compared to previously identified network metrics.

Figure 69 is a model product that illustrates system performance with respect to data latency when four types of nodes are active participants and the COP

update sent is set at 0.1Mb. The four participant nodes were assigned capacity values that govern the amount of information flow each node accepts. To represent the ASW unit's bandwidth capacity, 2.0Mb, 1.0Mb, 0.7Mb, and 0.5Mb were used as capacity values for the ASW participants.



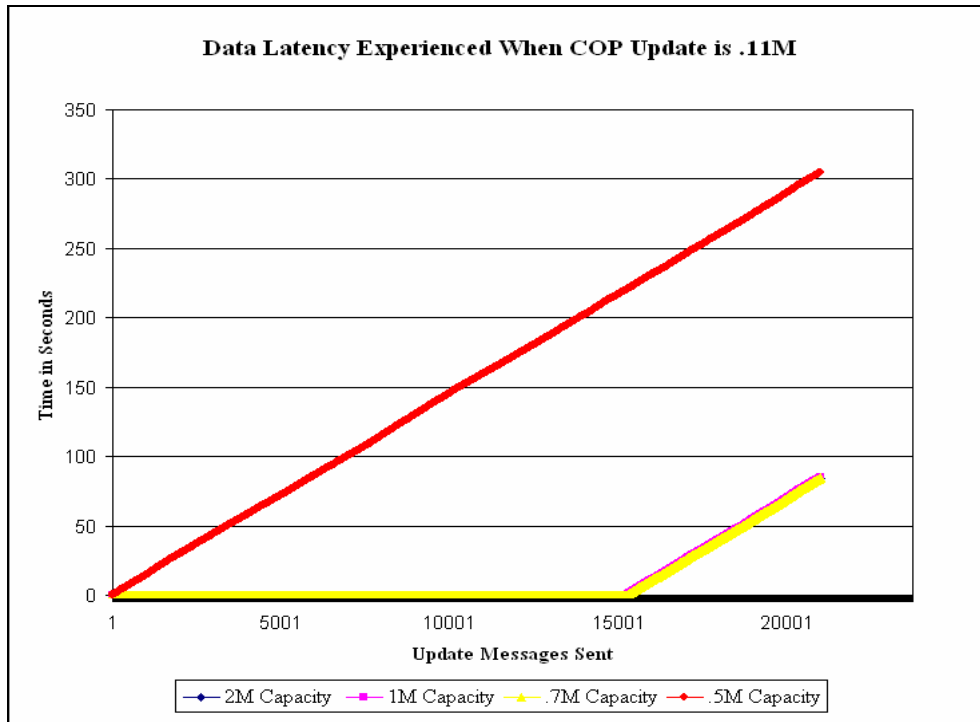
**Figure 69: Data Latency When COP Update is 0.1Mb**

After running the model for 2,000 iterations, data latency for each participant node was calculated by measuring the time from COP message update generation to the message's exit at each node. When the COP update is set at 0.1Mb, latency variance increases as the node's capacity is decreased. For instance, when a node has a bandwidth capacity of 2.0Mb very little data latency variance exists about the 0.05 second mean value. A 1.0Mb-capacity node increases latency time by a factor of two, thereby increasing fusion time to 0.10-0.15 seconds. The 0.7Mb-capacity node behaves in a similar fashion to the 1.0Mb node. However, the 0.7Mb node is limited because the amount of data received is greater than the bandwidth available. The result of processing data packets that are larger than the available capacity is evident in the latency time and amount of variance that exists. Latency times experienced by the 0.7Mb node

range from 0.14 to 0.24 and vary considerably about the mean value of 0.19 seconds. Of the four nodes, the 0.5Mb-capacity node maintained the greatest amount of latency. Additionally, Figure 69 illustrates confidence intervals of 0.05 and 0.95 to capture the large variance amount. Analyzing the 0.5Mb-capacity node is critical since it is the least-capable participant. With a 0.24 mean latency value, the 0.5Mb-capacity node can be expected to deliver or fuse 0.1Mb packets of information within 0.32 seconds 95% of the time. If a 0.5Mb-capacity node is acting as a participant, system performance will decrease due to the limited capacity of the least capable node. Consequently, if the 0.5Mb node is a relay in the network system, data latency of the 0.5Mb node will have to be added to the final node.

Sensitivity within the model was achieved by varying the COP output update message size. By varying the message update size, an upper threshold for system capacity was determined. As shown in Figures 70 and 71, when the COP output update message is greater than 0.1Mb, the network system exhibits points of backlog exhaustion. The most significant system performance degradation occurs when the COP output update message size is 0.11Mb is contributed to the 0.5Mb-capacity node. In Figure 69, latency time was easily discernable since messages were fused at a regular rate below 0.5 second.

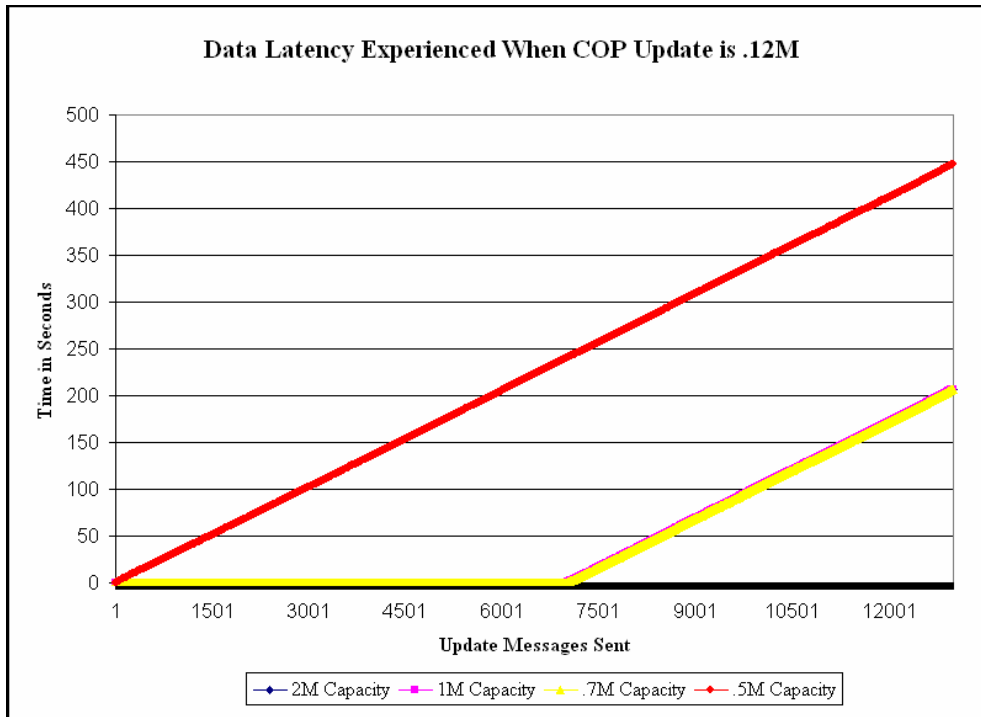
Figures 70 and 71 illustrate the difference in time between a specific message generation and that specific message's fusing time at the respective node. For instance in Figure 70, message number 3,500 was processed by the 0.5Mb-capacity node at time 50 seconds vice 3,500 messages were processed. Processing exhaustion or constant backlog occurs when fusing time and messages being processed increase at a constant rate. For example, in Figure 70, the 0.5Mb-capacity node immediately becomes backlogged and fuses messages at a constant increasing rate.



**Figure 70: Data Latency When COP Update is 0.11Mb**

It is interesting to note that as the COP output update message size is increased to 0.12Mb, a similar system performance is exhibited with upper processing bounds for each node. The upper processing bounds are a result of a message generation and fusing time difference that remains a constant time interval. In Figure 71, an upper constant processing bound is achieved at 240 seconds per message by the 2.0Mb-, 1.0Mb-, and 0.7Mb-capacity nodes. The constant difference in fusing process time, as shown in Figures 70 and 71, can be attributed to the model's queuing effects and node's capacities. To represent real backlog effects, the number of messages arriving exceeds the delay time in which they are processed at each node.





**Figure 71: Data Latency When COP Update is 0.12Mb**

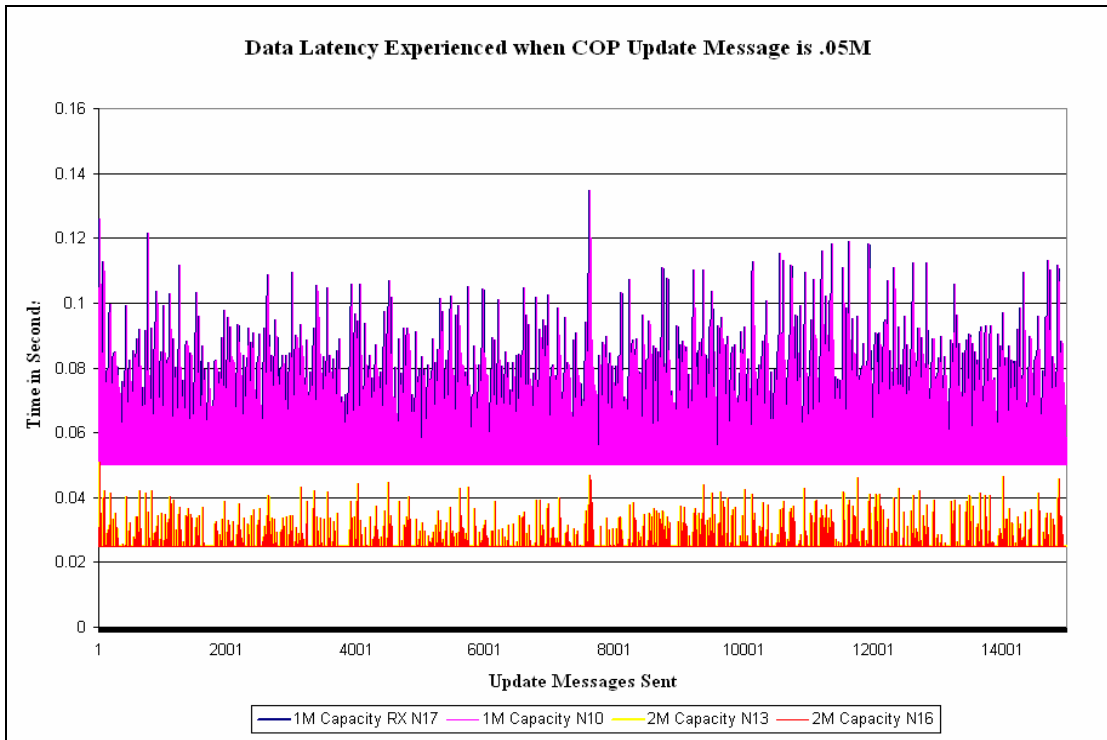
When the rate at which message processing and message arrival are equal, model queuing functions continue to retain previously generated messages and deliver the messages based on the message capacity delay. As the capacity delay function releases a message as if it were processed, the respective queue will deliver the next message. The queuing and delay functionality is similar to today’s “publish and subscribe” network operations. Such delays can be expected when there is not a reset function within the message processing logic. To avoid experiencing exhaustion and excessive backlog when processing 0.12Mb COP output updates, nodes that have a capacity equal to or greater than 0.7Mb should reset message fusing processors after 6,000 messages, roughly every 25 minutes.

To show the effects of processing 0.2Mb update messages, Figure 72 indicates server degradation in system performance. Only the 2.0Mb- and 1.0Mb-capacity nodes are able to constantly process the update messages at 1-second intervals until a threshold is reached. Using 0.2Mb update messages greatly reduces system performance and ultimately limits active participants to capacities greater than 1.0Mb. Message interarrival time could be adjusted for the limited capacity node

receivers. However, the update frequency for limited capacity nodes would not meet near-zero, real-time, military requirements.

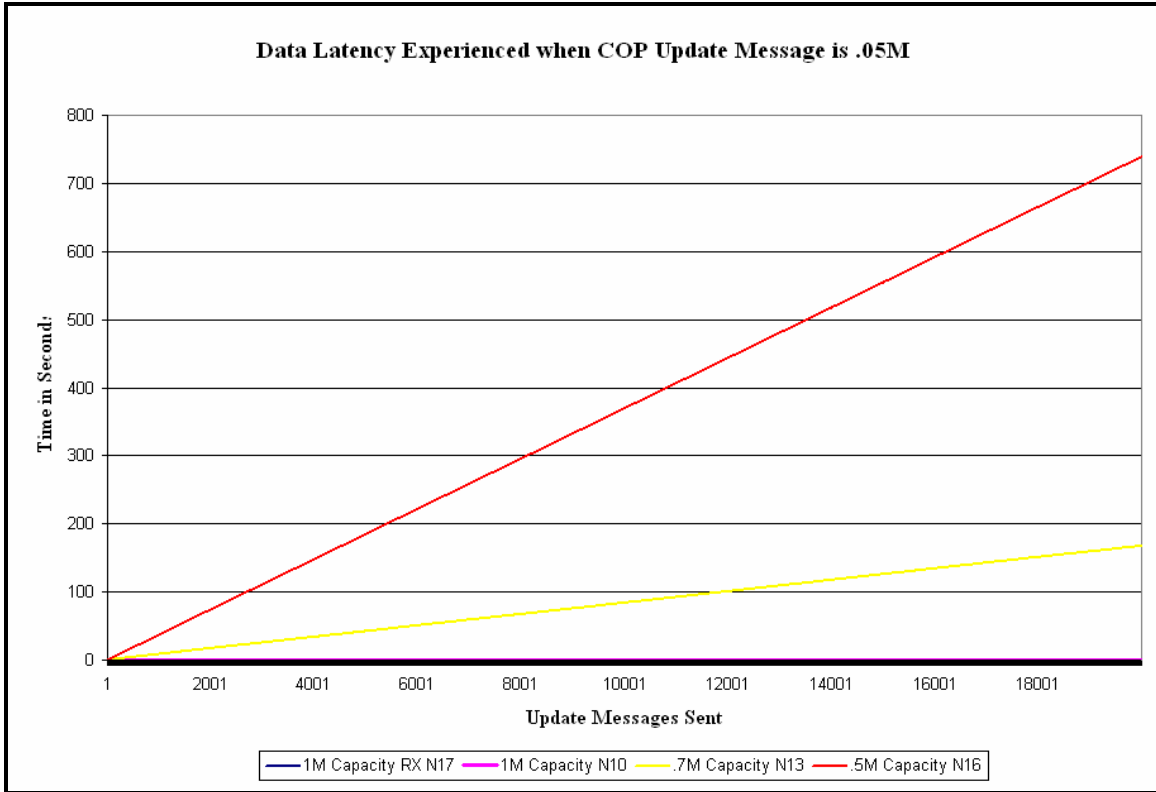
To determine which variable has the most effect on network system performance the additional nodes were added to the centralized network architecture, while input and output COP update messages were adjusted to affect data latency. Thirteen additional participant nodes of large, medium, and small capacities were added to the network system. All participant nodes generated constant-sized messages to represent input COP update messages. Likewise, all additional participant nodes received and fused central node COP output update messages that were also varied. Figures 72 through 76 illustrate the performance relationships between the numbers of participant nodes, COP input update messages size, COP output update message size, and the frequency that update messages are sent.

Figure 72, Data Latency Experience when COP Update Message is 0.05Mb indicates node specific data latency as the delta between update message generation and message fusion on a specific node when 12 additional nodes affect the system. In comparison to Figure 69, where only 5 nodes affect network performance, there is not a significant difference in performance when 12 nodes are added as network participants. The reduced size of the output COP update message from 0.10Mb to 0.05Mb contributed the most notable performance improvement. By halving the 0.10Mb update message and holding node capacities constant, data latency was lowered from 0.10 to 0.06 second for a 1.0Mb-capacity node. Although Figure 72 does not illustrate performance for medium and small capacity nodes, Figure 73 shows the data latency experienced for 0.7Mb and 0.5Mb nodes when there were 17 network participant nodes and the out COP update message was 0.05Mb.



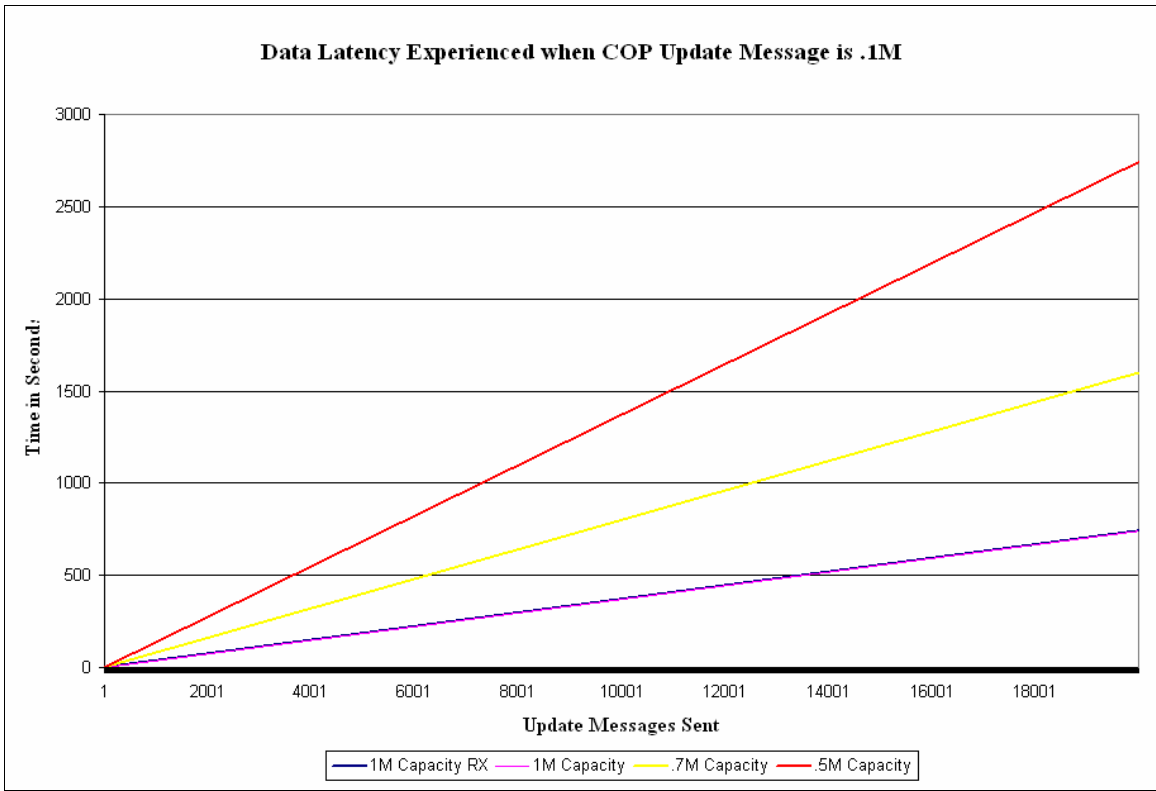
**Figure 72: Data Latency Experience When COP Update Message is 0.05Mb**

From Figure 73, the largest difference in network performance for medium- and small-capacity nodes is indicated by the immediate backlog that occurred for both the 0.5Mb- and 0.7Mb-capacity nodes. Since the output COP update message size and frequency was held constant at 0.05Mb, the addition of 12 network participants directly resulted in the backlog experienced for the 0.7Mb and 0.5Mb participant nodes. Also in Figure 73, 1.0Mb-capacity node performance remained below 0.15 seconds and is represented along the X axis.



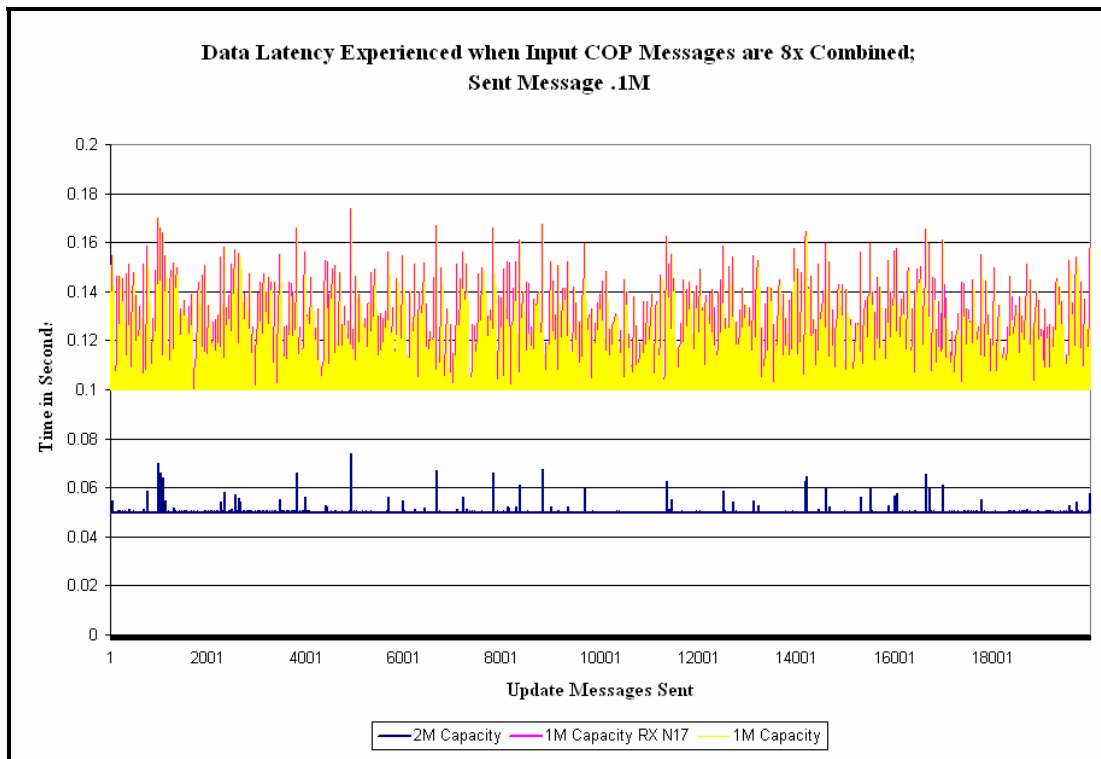
**Figure 73: Data Latency Experienced When COP Update Message is 0.05Mb**

The differences in network performance between an architecture where only 5 nodes participate and was optimal with 0.1Mb output COP messages can be seen here. When the output COP update message size was increased to 0.1Mb for the 17-node architecture, backlogs immediately occurred. Figure 74 shows the data latency that was experienced for large-, medium-, and small-capacity nodes when the output COP update message is 0.1Mb in the 17-node network architecture. The increase in output COP update message size directly resulted in a backlog across the three node types. After recognizing that a backlog was experienced across the nodes when the COP update message size was 0.05Mb and 0.10Mb, network operation should support COP update message sizes of 0.1Mb or greater. The determination to keep COP update messages at 0.1Mb or above led to additional sensitivity analysis that addressed the frequency of output COP update messages sent.



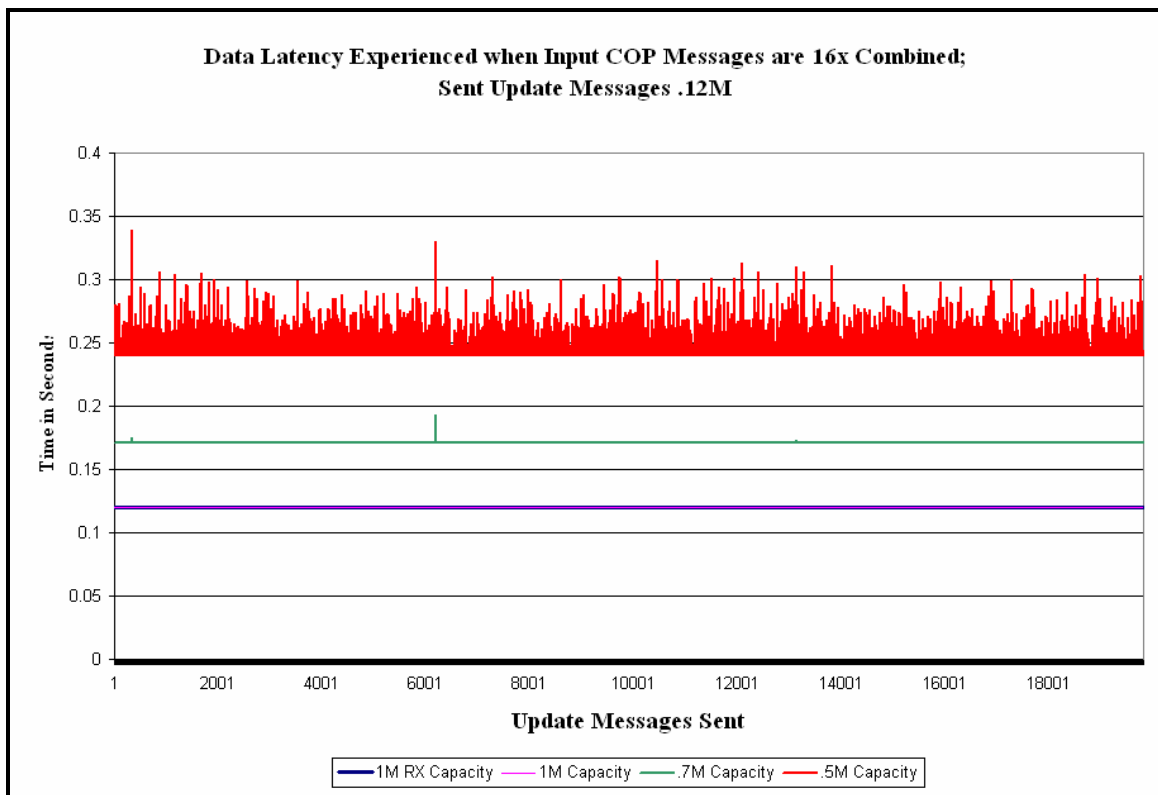
**Figure 74: Data Latency Experienced When COP Update Message is 0.1Mb**

Figure 74 and 75 illustrate data latency experienced in the 17-node network architecture when the output COP update message frequency is decreased from 4 input messages that are fused to generate 1 output COP update message. To decrease the frequency that output COP update messages are received at each node, the central node within the model was adjusted to combine input messages at a rate of 8, 12, and 16 to generate 1 output COP update message. Figures 74 and 75 are appropriately labeled “8 times” and “16 times combined” to signify the ratios and the decrease in sent message frequency. Figure 74 indicates that large capacity nodes were not significantly affected by the frequency decrease when output COP update messages were combined 8 to 1. Comparatively, the network performance results shown here mirror results shown in Figure 69, where messages were combined 4 to 1 and only 5 nodes were network participants. Additionally, medium- and small-capacity nodes are not represented in Figure 74 to highlight the data latency experienced by the 2.0Mb and 1.0Mb nodes. Data latency experienced by the medium- and small-capacity nodes was similar to previous results where backlog occurred immediately.



**Figure 75: Data Latency Experienced When Input COP Messages are 8x Combined; Sent Message 0.1Mb**

Analysis was also conducted for 12 to 1 output COP update messages sent and is not illustrated here since it would show network performance suboptimized for a 0.1Mb output COP update message size. The follow-on sensitivity analysis shown in Figure 75 indicates that a larger output COP update message size can be achieved by combining 16 input messages for 1 output update message sent. Figure 75 represents network performance and the data latency that was experienced by 1.0Mb, 0.7Mb, and 0.5Mb node participants when update messages were 0.12Mb in size and input messages were combined 16 to 1. In comparison to Figure 69, where large-, medium-, and small-capacity nodes experienced similar data latency, the greatest performance difference occurred for the small 0.5Mb-capacity node. Although the mean data latency for the 0.5Mb participant node is the same, variance in performance for the 0.5Mb node was significantly reduced.



**Figure 76: Data Latency When Input COP Messages are 16x Combined; Sent Update Messages 0.12Mb**

From Figure 69, 0.90 of the messages fused by the 0.5Mb participant node in a 0.1Mb update message and 5-participant network architecture occurred between

0.2 and 0.32 seconds. Whereas from Figure 75, 0.90 of the messages fused by the 0.5Mb participant node in a 0.12Mb update message and 17-participant network architecture occurred between 0.24 and 0.27 seconds.

3.4.1.2.1 ABOVE THE SEA DATA TRANSFER MODEL CONCLUSIONS. The following points are conclusions taken from above the sea data transfer modeling. After completing a thorough sensitivity analysis on network performance, based on additional nodes, input and output COP update message sizes, and the frequency update messages were sent, it was found that a relationship exists between the number of participant nodes, node capacities, and the update message sent frequency. Specifically, the frequency that update messages were sent has the greatest effect on network system performance.

For a network system with more than 15 participants where limited capacity nodes such as the 0.5Mb-capacity node are present, update messages should be less than 0.12Mb and sent at a frequency that allows for consistent processing to support COP update fusion times of less than 0.5 second locally and 1 second for final nodes in a relay. When COP update message sent frequency exceeds the ability of limited capacity nodes, participant nodes with receiving capacities less than 0.5 cannot be expected to perform critical, time-sensitive operations. The relationship between frequency and network participant numbers from this model that was found to optimize system performance was determined to be 4 to 1 for a 5-participant node system and 16 to 1 for a 17-participant node system. As a result of this finding, a determination was made for the message combination and the frequency update messages were sent. The determination made was that the central node fusion of update messages sent should occur at a rate of 1-N, N for the number of participants to 1 output COP update message. Additionally, COP update message size should increase as the update message sent frequency is reduced.

With respect to bridging undersea and atmospheric battlespace networks, forming a radio frequency gateway between sea sensors and air data networks was represented in this model by the addition of a single, limited-capacity, transmitting node. Analysis of the node indicated that for the node to effectively operate, transmitted packets should be half the node's capacity. For this model, extremely small amounts of



data were contributed by the gateway node. Gateway node packets were set at 500 bits for a transmit capacity of 1.0Kb. Data latency due to transmitter capacity that was experienced did not have a significant effect on the overall system performance. Since gateway node update rates followed a triangular distribution between 10 seconds and 20 seconds, with a respective mean value of 15 seconds, an excessive amount of backlog or node exhaustion did not occur. A 15-second mean value gateway transmission time was proven by this model as a feasible capability that has a major impact on the reduction of the prosecution timeline.

### **3.4.2 Deployment Modeling**

#### ***3.4.2.1 Introduction***

The littoral regions of the globe present multiple challenges for the US military in the 2025 time frame. These challenges require the US military to develop a robust underwater SoS that will combat these challenges and provide the US military with a dominate capability in the littoral region. This underwater SoS will couple existing and new technologies with conventional and unconventional methods of delivering and deploying underwater sensor systems to the AOR. The ultimate goal for the US military will be the safe and clandestine delivery and deployment of these sensor systems from predetermined standoff ranges, thus decreasing Blue force vulnerability in the AOR.

In an effort to provide a rapid response solution to ASW in the littorals in 2025, the use of subsurface and/or airborne delivery methods of UUV assets appear to be the most viable approach. However, an initial assumption considered for this problem will be the US military's lack of air superiority in the AOR. This assumption places greater emphasis on the use of subsurface deployment vehicles and airborne delivery methods that can be deployed beyond the boundaries of the AOR. Additionally, if surface ships are to play a viable role in the littoral region, it will likely be from a distance outside the AOR unless their operation within the AOR maximizes success, while maintaining a minimal risk to Blue forces.

This section provides an overview of the methodology and approach utilized when modeling the effective and efficient deployment of each of the four SoS alternatives developed during the Alternatives Generation process. Several modeling

software packages were evaluated for their applicability and the successful adaptation required to achieve desired output data. The models and modeling software identified and considered for use were Monte Carlo simulation models, EXTEND, the Joint Expeditionary Logistics Operations Model (JELO) and the creation of an original model using Excel spreadsheets coupled with a statistical analysis package. After careful consideration, the creation of a stand-alone, Excel-based model inspired by characteristics of the JELO model, proved to be the best choice.

Research was collected on all potential deployment assets: surface, subsurface, and air. The research included quantifiable characteristics such as speed, payload capacity, logistics requirements, logistics capabilities, and sustainability and were recorded and analyzed for potential capabilities in each of the five alternatives considered. Data regarding each individual asset, its logical point of origin, transit route, and distance to the AOR were evaluated. These characteristics were entered into the Excel deployment model to determine their viability within each alternative and for the overarching SoS.

The deployment modeling effort was entirely scenario driven and designed to satisfy each of the alternatives described in previous sections. The focal point for each alternative centered on the need for US assets to achieve rapid undersea maritime dominance in the littoral region in the 2025 time frame. Initially, five alternatives were explored to satisfy the SoS. However, the fifth alternative, using a floating sensor grid, was determined to be an infeasible alternative and therefore not included in the modeling effort.

Modeling each of the four alternatives designed for the SoS required multiple simulation iteration to achieve stability within the data sets and provide an accurate representation of real world possibilities and constraints. Each alternative was subject to identical metrics allowing for uniform, in-depth analysis within and over each alternative. In order to implement the deployment model, several documented assumptions were made. These assumptions were made to reach the proper mix of time, space (distance), and force in deploying the SoS. The deployment model could not be adjusted for the factor of time. The inability to slow or speed up the factor of time forced the SEA-8 Deployment Team to find diverse and wide-ranging force compositions

originating from various distances. To evaluate the success of each alternative, each metric used the factor of time as its basis. Once each alternative was evaluated against the same set of metrics, analysis of advantages and disadvantages for each alternative was conducted. The alternatives were then compared to determine which alternative best met the challenge of undersea maritime dominance in the littorals in the 2025 time frame.

#### ***3.4.2.2 Methodology***

SEA-8 used an effects-based methodology. The Deployment Team modeled each alternative to determine the optimal combination of deployable assets necessary to achieve a Pd of 0.5 within the first 72 hours, within a 100-square NM area, located outside each of three port facilities, and a Pd of 0.8 within a 20,000-square NM area, encompassing the entire AOR, within 10 days. Deployment scenarios were then developed in an effort to satisfy each of the Pd requirements. In combination with the requirements stated above, an exhaustive list of deployable assets to include surface, subsurface, air, and deployment locations was generated to be incorporated in each of the four alternatives' deployment scenarios.

#### ***3.4.2.3 Research and Assumptions***

Collective and exhaustive research was conducted on all assets necessary to deliver SoS components to the AOR. Characteristic data, consisting of performance and design specifications, were utilized in conjunction with statistical data collected from historical performance and operations. This characteristic data was utilized when considering existing deployment assets. When researching PORs for future systems, analogies between similar existing systems, as well as a review of material concerning these systems, predicted operating characteristics and test and evaluation data were utilized to develop data for implementation in the deployment model.

A number of assumptions were also required during the research and data collection phase. The specific data required for input into the deployment model is listed below. Any and all assumptions made are clearly defined throughout this section of text.

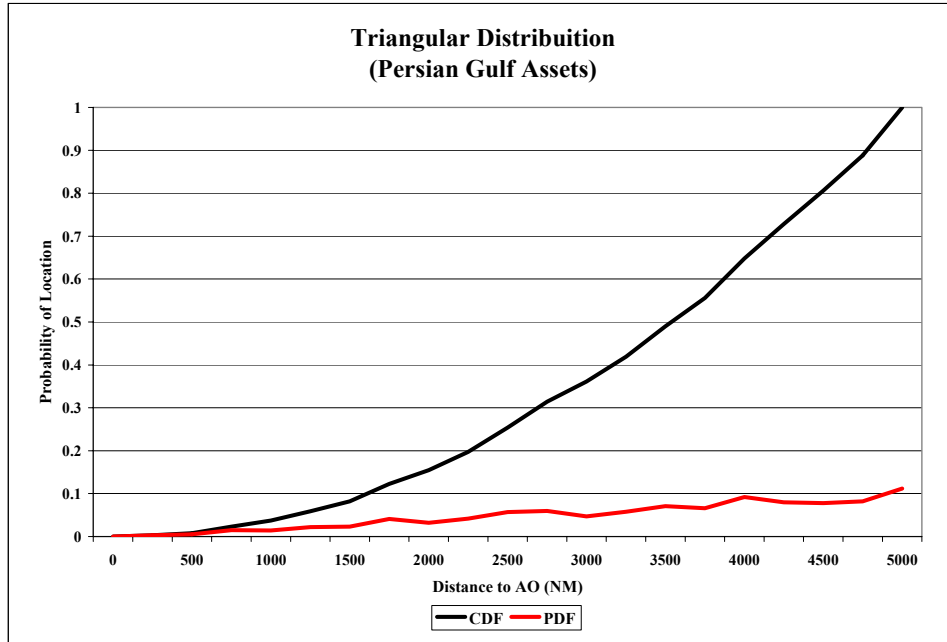
#### 3.4.2.3.1 DEPLOYMENT ASSET CHARACTERISTICS.

- Asset Speed: Asset speed was broken down into three distinct and separate categories:
  - Maximum: Greatest speed with no regard for payload or endurance
  - Transit: Typical speed when traversing great distances requiring replenishment of fuel or logistics. Replenishment was consistent and available. For the purposes of this model, transit speeds for all aircraft, surface ships, and submarines were utilized. Endurance speeds were utilized only when no published transit speed data existed
  - Endurance: Speed capability when traversing great distances requiring replenishment of fuel or logistics. Replenishment was inconsistent and potentially unavailable. Distance is optimized with respect to speed
- Asset Payload Capacity: Asset payload capacity was broken down into two distinct and separate categories:
  - Maximum: Maximum payload capacity was derived from published literature such as load plans and technical manuals
  - Endurance (Working) Payload: Determined through professional expertise and assumed for the purposes of this model that all aircraft will take off and transport no more than 85% of the maximum listed payload capacity
- Transit Distance:
  - Air Assets: All distances utilized for aircraft were determined utilizing the mathematical result of great circle sailings from the asset's departure location to the leading edge of the AOR
  - LAG (Surface, Subsurface): All distances utilized for surface ships and submarines associated with LAG forces were determined using historical deployment routes for CSG and ESG. Distances were determined using existing and proposed US operating patterns to determine the optimal approaches from air, surface, and subsurface

assets. These distances, combined with planning factors, provided an ability to generate modeling outputs that determined an optimal force combination necessary to achieve the Pd and time requirements for each alternative. Due to the unpredictable nature of the exact location of deployed assets and the subsequent distance that may be between these assets and the AOR, a triangular distribution was utilized to demonstrate movements of assets and their average required transit distance

- TSSE Sea TENTACLE: The calculation of the TSSE transit distance was derived by assuming a maximum distance and minimum distance from the AOR that the TSSE ships would be located at any one time. These ships are anticipated to operate with logistics support and escort assets until approximately 800 NM from the AOR. At this distance, TSSE ships will proceed unaccompanied at sprint speed until 200 NM from the leading edge of the AOR. At this distance, the TSSE ships will deploy all onboard sensor assets. A triangular distribution was used to simulate probability of distance. A total time to transit and deploy assets was derived

An example of the triangular distribution utilized is shown in the modeling screen capture, in Figure 77.



**Figure 77: An Example of a Triangular Distribution Utilized for Calculating the Transit Distance of Deployed Assets**

The Triangular Distribution was utilized to generate Figure 77 to produce required distance inputs to the global location table (Table 5). Table 5 derives transit times based on speed and replenishment requirements.

	Global Location	Distance to AO (NM)
1	CONUS (Central) (B-2 Whiteman AFB, MO)	8060
2	CONUS (Central) (B-52 Barksdale AFB LA)	7902
3	CONUS (East) (thru Suez)	13315
4	CONUS (East) (thru Straits of Magellen)	12132
5	CONUS (West) (San Diego)	7109
6	Diego Garcia	4600
7	Guam (B-52)	3187
8	Pearl Harbor	5960
9	Saipan	3692
10	Saipan (B-52)	3290
11	Yokuska	4896
12	CSG (Persian Gulf Deployed)	2774
13	CSG (SE Asia Deployed)	2691
14	ESG (Persian Gulf Deployed)	2482
15	ESG (SE Asia Deployed)	3495
16	LAG* (SE Asia Deployed)	3896

**Table 5: Transit Distance for All Assets**

- Logistics:
  - Fuel constraints: For the purposes of this model, it was assumed that all assets will operate to a minimum of 15% fuel remaining onboard before requiring refueling
  - Fuel supply: It was further assumed that in-flight refueling of B-2 and B-52 aircraft will occur as required. Surface assets will refuel as required when outside of the AOR
- Administrative:
  - Crew rest: Flight crew rest will occur as required. Flight crew rest was determined to be 12 hours per flight and may occur concurrently with off-load/on-load of the aircraft
  - Administrative/logistics will occur concurrently with transit time of all assets
  - Maintenance: Maintenance to aircraft assets may occur concurrently with onload/offload
- Replenishment:
  - Replenishment of all assets with food, stores, and parts will occur concurrently with the transit times

All asset research data and assumptions were entered into the deployment model. The input table (Table 6) was used to conduct sensitivity analysis of transit speeds, payload capacities, and replenishment thresholds.

Each of the possible deployment assets are listed on the far left column, while operating characteristics are listed across the top. Researched data was entered as hard numbers, while assumptions such as payload and replenishment thresholds were entered in yellow for continued sensitivity analysis.

AIR	Endurance	Transit Speed	Max Speed	Max Payload capacity (tons)	Working Payload	Max Range (NM)	Organic sensor assets (number and type)	Max Endurance (hours)	Payload Threshold Ratio	Utilized Asset Speed	Total Max Operating hours (fuel)	Total Max distance traveled due to logistics re-supply	Refueling Threshold	Fuel Threshold Ratio
B-2	300	400	550	20	18	10000	Web-sensors, UUV, Mines, (to be tailored dependent on mission assigned)	36.00	0.90	400	25.00	N/A	21.25	0.85
B-52 (G)	352	442	516	35	31.5	6513	Web-sensors, UUV, Mines, (to be tailored dependent on mission assigned)	18.50		442	14.74	N/A	12.53	
B-52 (H)	352	442	516	35	31.5	8685	Web-sensors, UUV, Mines, (to be tailored dependent on mission assigned)	24.67		442	19.65	N/A	16.70	
P-8 (MMA)	300	440	490	29	26.1	1400	Web-sensors, UUV, Mines, Torpedoes (to be tailored dependent on mission assigned)	4.00		440	3.18	N/A	2.70	
C-5	465	489	541	145.5	130.95	2960	N/A	6.37		489	6.05	N/A	5.15	
F-18 EF	275	420	960	2	1.8	1200	Torpedos, Mines, UUVs	2.25		420	2.86	N/A	2.43	
F-35 JSF	275	420	1080	2	1.8	1200	Torpedos, Mines, UUVs	1.80		420	2.86	N/A	2.43	
SURFACE	Transit Speed	Range (NM)	Max Speed	Payload capacity (tons)		Max Range (NM)	Organic sensor assets (number and type)	Logistics Provisions limitations (hrs)		Utilized Asset Speed	Total Max Operating hours (fuel)	Total Max distance traveled due to logistics re-supply	Refueling Threshold	
DD(X)	16	44000	30	6		44000	2 SH60R LAMPS Helos, 3 RQ-8A Fire Scout VTUAV, Acoustic Sensor Suite	720		23	1913.04	16560	1626.09	
DDG	16	44000	31	6		44000	2 SH60R LAMPS Helos, 3 RQ-8A Fire Scout VTUAV, AN/SQS 530(V) Sonar AN/SQR 19(V) TACTAS Sonar	720		23.5	1872.34	16920	1591.49	
LCS	20	4300	50	40		4300	1 MH-60R/S/UAVs/NTUAVs	504		35	122.86	17640	104.43	
T-AOE(X)	20	10000	26	1800		10000	N/A	720		23	434.78	16560	369.57	
TSSE SHIP	25	4500	45	0		4500	TBD	504		25	180.00	12600	153.00	
SUB SURFACE	Notional Transit speed (kts)	Range (NM)	Max Speed	Payload capacity (tons)		Max Range (NM)	Organic sensor assets (number and type)	Logistics Provisions limitations (hrs)		Utilized Asset Speed	Total Max Operating hours (fuel)	Total Max distance traveled due to logistics re-supply	Refueling Threshold	
SSN	20	Indef	25	6		Indef	ANB/SY Active passive sonar, AN/WLG-4(V)1 ES receiver, TB-23 Towed array	2160		22.5	N/A	48600	N/A	
SSGN	15	Indef	25	6		Indef	BQS-13 Active Sonar, TB-16 Towed Array	2160		20	N/A	43200	N/A	

**Table 6: Modeling Input Data for Potential Assets**

3.4.2.3.2 SENSOR COMPONENTS. During the Alternatives Generation Phase of the SEDP, all possible deployment assets that provided value to the overall effectiveness of the SoS were identified. This list of potential contributors was subsequently reduced to a limited number of quality and practical assets. The process began with the identification of the sensor components and related support assets required to be deployed and their inherent characteristics. The identification process generated the following list of sensor components and support assets:

- Sea-web sensor component
- Man-portable UUV
- LWV UUV
- HWV UUV
- Recharging station

In addition to the identification process, a set of assumptions was also developed to account for the relatively new and uncertain nature of UUV technologies:



- A reliability factor for each of the sensor components during delivery and deployment was assumed
- Sensor components will require a shape or carrying container that will increase the overall weight of the payload
- Tonnage is a better metric than volume when considering the capacity of a deployment asset

Additionally, each sensor asset has a distinct and specific weight, diameter, endurance, and capability. These characteristics drive deployment options, require different levels of sustainment, and may require potential recovery assets. Table 7 depicts these characteristics and the methodology for entering each into the deployment model. Data for diameter, displacement, and endurance were obtained from The Navy UUV Master Plan.<sup>152</sup>

Sensor Components	Number of Sensors Required	FMC (.96)	Number of Sensors to be deployed	Displacement (tons)	Shape Tonnage	Endurance (High Hotel Load) Hrs	Edurance (Low Hotel Load) Hrs	Recharge Required (hrs)	Repair Required (hrs)	Replacement Required (hrs)	Total Tons
UUV (Man Portable)	0	0.96	0	0.005	0.005	10	20	20	120	240	0.00
UUV (LWV)	0	0.96	0	0.25	0.25	20	40	40	240	480	0.00
UUV (HWV)	51	0.96	53	1.5	1.5	50	80	80	480	960	159.12
UUV (Large)	0	0.96	0	10	10	300	400	400	2400	4800	0.00
Recharging Station	12	0.96	12	1	1	360	720	720	4320	8640	24.96
Floating Sensor (sonbuoys)	0	0.96	0	0.015	0.015	120	240	240	1440	2880	0.00
Sea-Web Component (Medium)	0	0.96	0	0.055	0.055	120	240	240	1440	2880	0.00
Sea-Web Component (Large)	0	0.96	0	0.075	0.075	120	240	240	1440	2880	0.00
										Total Tonnage req for deployment	184.08
										Payload tonnage Available	229.50
										Remaining/ Needed	45.42

**Table 7: Payload Data for Modeling Input**

Each possible sensor asset was listed down the left-hand column of Table 7, while operating and performance characteristics were listed across the top. The number of sensor assets necessary to meet the desired Pd requirements were input into the sensors required column. An FMC rating was incorporated in the table as a means of determining each asset's availability and to ensure the appropriate numbers of

<sup>152</sup> Department of the Navy, *The Navy Unmanned Undersea Vehicle (UUV) Master Plan*, 9 November 2004, p. 67.

components were deployed to the AOR. Subsequent columns illustrate the assets' weight in tons, endurance in hours and the expected frequency of recharging, repairing and replacement of assets. From this information, the number of assets required and the overall combination of sensor assets for each alternative could be determined. This quantity, coupled with its inherent weight and the weight of its shape, have been summed in the far right column to produce a total tonnage required to satisfy each alternative's requirements. The total tonnage of sensor components required drives the total number of deployment assets required for delivery to the AOR.

### **SENSOR RELIABILITY**

Inferences and parallels were drawn between existing systems and those listed above. When considering deployment of UUVs in the year 2025, a level of failure needs to be assumed. Deploying assets into a harsh environment, such as an unpredictable ocean, has the potential to increase electronic component failure over time. This deployed failure rate is modeled and discussed in the sustainment section of this report. For the purposes of deployment, an FMC rating was derived from analogous assets such as the JSOW which enjoyed a success rate of 96% during OPEVAL in 1997.<sup>153</sup>

In 2000, the Joint Direct Attack Munition (JDAM) "recorded an unprecedented 95 percent system reliability during development testing and has achieved better than required accuracy."<sup>154</sup> Finally, during Operation Allied Force, "six B-2s flying 30-hour missions from Whiteman [Air Force Base] (AFB) flew 45 combat sorties and delivered over 1.4 million pounds of weapons with a 98% JDAM reliability."<sup>155</sup> Using an analogy method with the operation and test data points above, the sensor assets were determined to have a reliability of 96% on deployment into the AOR.

### **SENSOR SHAPE**

While transporting and deploying these sensor components, it can be assumed that these components will require a carrying container. This added piece of equipment has the potential to be bulky, consuming space and adding excess weight to the payload, thus

---

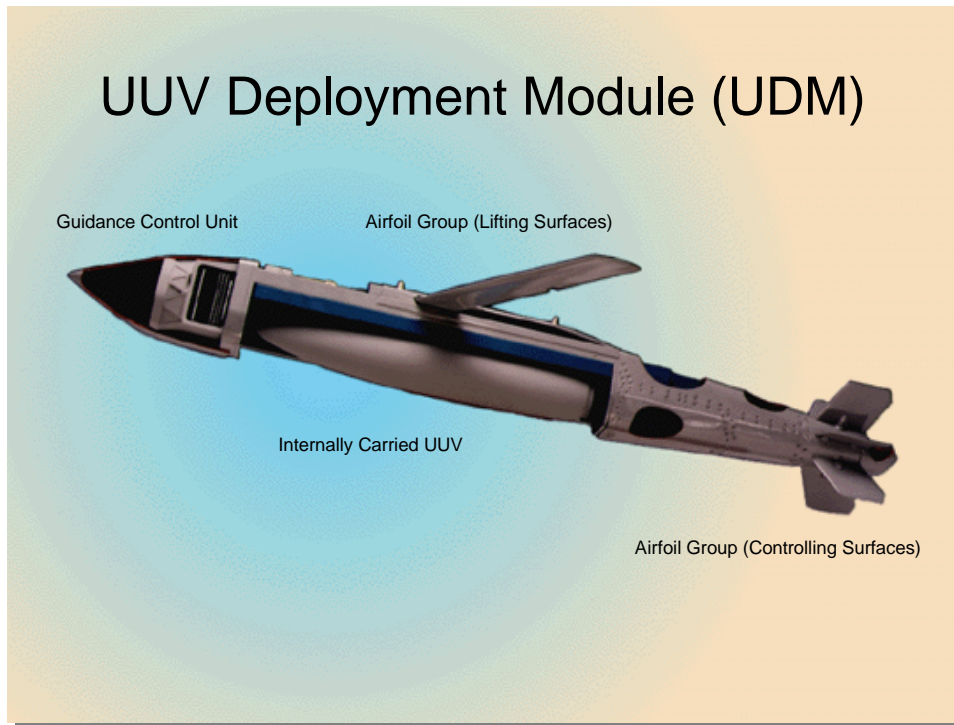
<sup>153</sup> [www.boeing.com/news/releases/2000/news\\_release\\_000224n.htm](http://www.boeing.com/news/releases/2000/news_release_000224n.htm).

<sup>154</sup> [www.fas.org/man/dod-101/sys/smart/agm-154.htm](http://www.fas.org/man/dod-101/sys/smart/agm-154.htm).

<sup>155</sup> [www.capitolsource.northropgrumman.com/programs/b2.html](http://www.capitolsource.northropgrumman.com/programs/b2.html).

requiring additional deployment assets. For the purposes of this model, an assumption was made that the container weight will be equal to that of the weight of the sensor component. For example, a HWV class UUV weighing 3,000 lbs, or 1.5 tons, would require a container weighing 1.5 tons, thus the total package would weigh 3 tons.

For air-deployed assets, a shape would be required in place of a container. A hypothetical concept similar to that of a JSOW could serve as an excellent deployment method for air-deploying UUVs clandestinely. The hypothetical UUV Deployment Module (UDM), shown in Figure 74, consists of a payload bay, an aerodynamically shaped shell, a guidance control group, and a flight control group. The cargo bay would be designed to accept six small Seaweb components or one HWV-class UUV. The shaped shell would provide for low drag, low observable carriage and glide performance at tactical airspeeds and the required lugs for carriage by the BRU-32 and Mk-38 launch rack. The outer casing is a clamshell design that would open at a specific position and altitude for delivery of the UUV.



**Figure 78: Hypothetical UUV Deployment Module for Air Deployments**

## **SENSOR TONNAGE**

The final assumption, when considering sensor assets, was sensor tonnage. Modeling input needed would have to be translated into a volume or a weight. When considering assets, terms of payload capacities, and published material (such as the UUV Master Plan), it was determined that weight would be the most appropriate and most universal metric.

### ***3.4.2.4 Requirements and Objectives***

When considering the scope of the requirements and objectives intertwined within the preparation, deployment, and sustainment of sensor components, it was clear that a focused approach on a limited area would produce the most beneficial results, vice a wide and varied one. Initial requirements and objectives which are listed below were streamlined to omit Requirement 1 and Objective 3.2.

- 1 Requirement: Sensor components maintained at highest state of readiness
  - 1.1 Objective: Provide continual readiness
    - 1.1.1 MOE: The capability to provide continual readiness
      - 1.1.1.1 MOP: Percent assets available for immediate deployment
        - 1.1.1.1.1 Goal: 100%
      - 1.1.1.2 MOP: Percent assets available for deployment within 48 hours
        - 1.1.1.2.1 Goal: 100%
      - 1.1.1.3 MOP: Percent assets available for deployment within 96 hours
        - 1.1.1.3.1 Goal: 100%
- 2 Requirement: Rapid and efficient delivery of sensor components
  - 2.1 Objective: Delivery of assets for initial sensor coverage
    - 2.1.1 MOE: The capability to deliver assets required for the initial mission
      - 2.1.1.1 MOP: Time required delivering assets to desired station
        - 2.1.1.1.1 Goal: Time < 72 hours
  - 2.2 Objective: Delivery of assets for follow-on sensor coverage
    - 2.2.1 MOE: The capability to deliver assets required for the follow-on mission
      - 2.2.1.1 MOP: Time required delivering assets to desired station
        - 2.2.1.1.1 Goal: Time < 10 days

- 3 Requirement: Effective sustainment of sensor components
  - 3.1 Objective: Provide logistic support required to sustain mission components
    - 3.1.1 MOE: The capability to sustain follow-on mission components
      - 3.1.1.1 MOP: Tons/day
  - 3.2 Objective: Provide mission components that require limited logistical support
    - 3.2.1 MOE: The capability to operate without support assets
      - 3.2.1.1 MOP: Time in water between replenishment, recharging, or repair
        - 3.2.1.1.1 Goal: Time > 240 hours

**3.4.2.5 Modeling of Alternatives**

Each of the four alternatives were modeled independently, utilizing a combination of assets to produce the most efficient and effective solution without confounding the data. The combination of alternatives was not considered during this phase. The research and assumptions discussed in previous sections were entered into the model as discussed above. From this data, the deployment model determined, based on inputs of transit speed and distance to the AOR, the ability of the asset to reach the AOR within timeline requirements. Based on the algorithm, if an asset was capable of reaching the AOR within 72 hours, the data cell would be color coded green. If the asset was capable of arriving after 72 hours, but no later than 240 hours (10 days), the data cell would be color coded yellow. If the asset could not reach the AOR until after 240 hours (10 days), the data cell would be color coded red. Table 8 highlights some of this data.

DDG	Transit Time (hrs)	Logistics Required	Payload	Off-Load/On-Load Time	Log Time (Crew Rest) (hrs)
0	566.60	153.40	0.00	0.00	0.00
0	516.26	203.74	0.00	0.00	0.00
0	302.51	417.49	0.00	0.00	0.00
0	195.74	524.26	0.00	0.00	0.00
0	135.62	584.38	0.00	0.00	0.00
0	253.62	466.38	0.00	0.00	0.00
0	157.11	562.89	0.00	0.00	0.00
0	140.00	580.00	0.00	0.00	0.00

**Table 8: Transit Time for a DDG by Color Code**

From Table 8, any asset capable of reaching the AOR within the required time constraints was considered for the next phase of the deployment model. Those assets unable to meet the time requirements were discarded as viable options. The acceptable assets were entered into the deployment model for further analysis. The deployment model performed 115 iterations to produce a sample size that could be considered an approximate representation of a population. The asset’s published transit speed was then entered into the model and triangularly distributed. Speed was multiplied by 0.5 and minus 0.1 about the mean. The values produced a simulated arrival time to further illustrate a percentage likelihood of arrival and an associated time.

3.4.2.5.1 ALTERNATIVE 1: TRIPWIRE. Alternative 1, Tripwire, requires the clandestine insertion of Sea-web components and HWV class UUVs. The cornerstone of this alternative is the successful deployment of the SoS within the first 72 hours of operations. This alternative provides sensor assets within the OA in the first 24 hours of operations.

**REQUIRED ASSETS:** Based on the short timeline, the lack of air superiority, and the time required for surface and subsurface assets to reach the OA, high altitude, air-deployed sensors represent the most viable option. Table 9 illustrates sensor assets components required and the necessary deployment assets.

Deployment Assets	Deployment Location	Sensor Assets Deployed to Achieve 96% FMC	Mean Transit Time (hours)	Deployment Time (hours)
B-2	Whiteman AFB	78 Seaweb Comp	20	0.1
B-2	Whiteman AFB	78 Seaweb Comp	20	0.1
B-52	Guam	8 HWV UUV	8	0.1
B-52	Guam	8 HWV UUV	8	0.1

**Table 9: Tripwire Assets**

**MODELING OUTPUT:** As stated earlier, the model produced 115 iterations of data. The primary output of this data set was in the form of aircraft arrival rate. From the aircraft arrival rate data set, both PDF and CDF could be generated for the aircraft utilized in this alternative. From the data input and the modeling output, the graphs in Figures 79 through 81 were derived. Based on data from Table 9, a graph depicting the number of aircraft arrivals per time step was constructed. Figure 79 depicts the number of times over the 115 iterations that the specific deployment asset arrived in the AOR. These occurrences are illustrated to provide a clear picture of the variability

within the output data. As an example, in Figure 79 a B-2 aircraft deploying from Whiteman AFB with a transit time of 20 hours arrived in the AOR at hour 20 in approximately 24 out of 115 iterations. Figure 79 also shows the same B-2 arriving as early as 18 hours after takeoff and as late as 29 hours after takeoff.

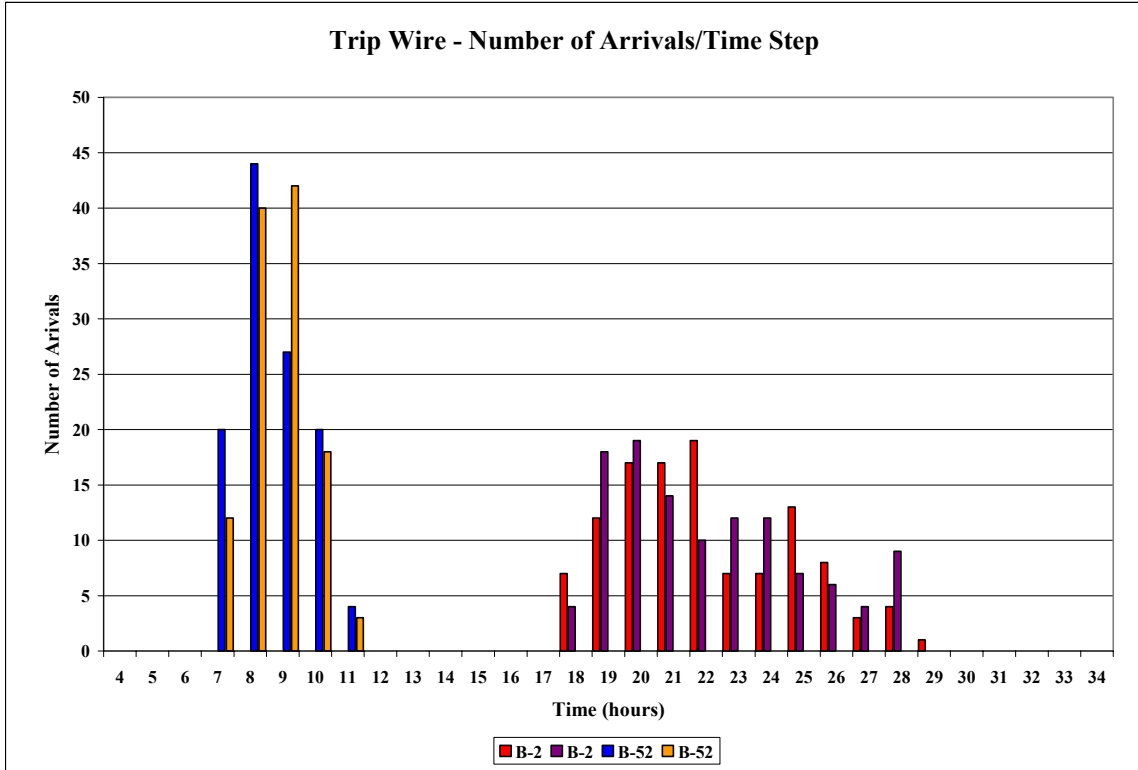
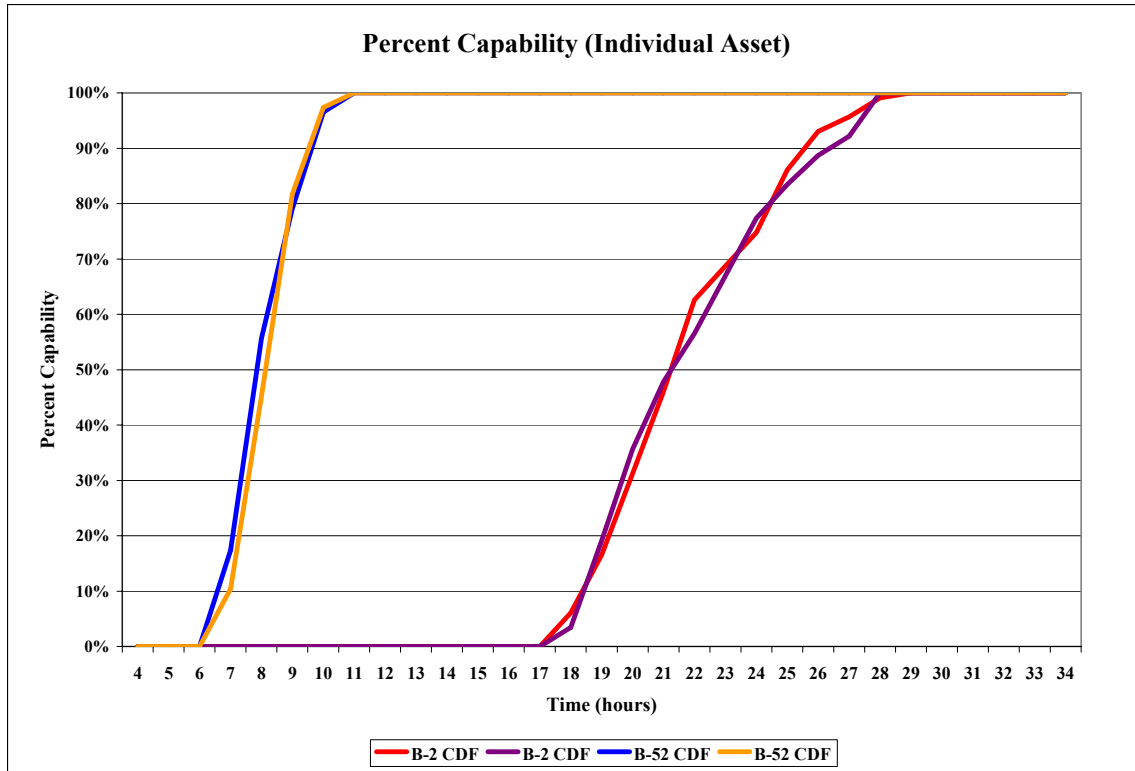


Figure 79: Tripwire – Number of Arrivals/Time Step

The data was analyzed to determine the percentage capability over time provided to the combatant commander. A CDF of the data was generated by individual asset to determine potential differences and capabilities provided. Figure 80 demonstrates a clear difference between the B-2 and B-52 aircraft based on arrival times. This can be directly linked to transit times of each aircraft.

The B-2s deploy from Whiteman AFB with a 20-hour notional transit, while B-52s that could be forward-deployed to Guam would have only an 8-hour notional transit time. Again, it is important to note that Figure 80 is based on the B-52’s ability to be forward deployed to Guam or Saipan, a luxury not afforded to the B-2s.

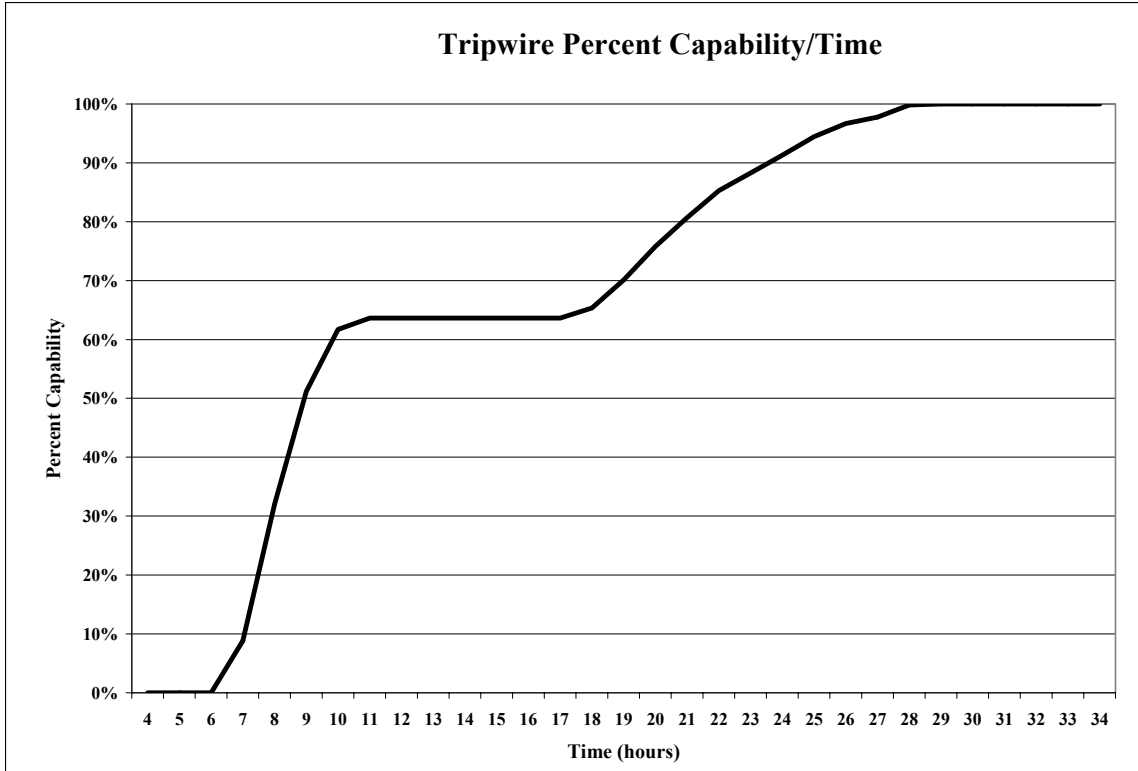


**Figure 80: Tripwire – Individual Percent Capability/Time**

A key aspect of all alternatives under consideration is the nature of components, their capabilities, how they are transported, when they arrive, and what the combatant commander actually has for capability when sensor assets do arrive. Because sensor assets can operate autonomously, a certain quantifiable capability is achieved per UUV or sea-web component delivered. These assets will continue to sense, track, trail, and provide data until they require a recharge, repair, or eventual replacement. Because all sensor components will require at least one of these within the 30-day scenario, additional components will be required. These additional assets, such as recharging stations or additional UUVs, constitute a deficiency in the thinking that 100% capability can be achieved without all components of the SoS.

In Figure 81, a combination of all aircraft assets was used to display a singular CDF for the Tripwire alternative. This was intended to show simulated percent capability from 0 to 100 over time steps.





**Figure 81: Tripwire – Combined Percent Capability/Time**

The occurrence of all sensor components' arrival in theater (Y-axis) by a certain time step (X-axis) is depicted in Figure 82. For example, 50% of the time, all assets will arrive in the AOR by hour 23, or 100% of the time, all assets will arrive in the AOR by hour 30.

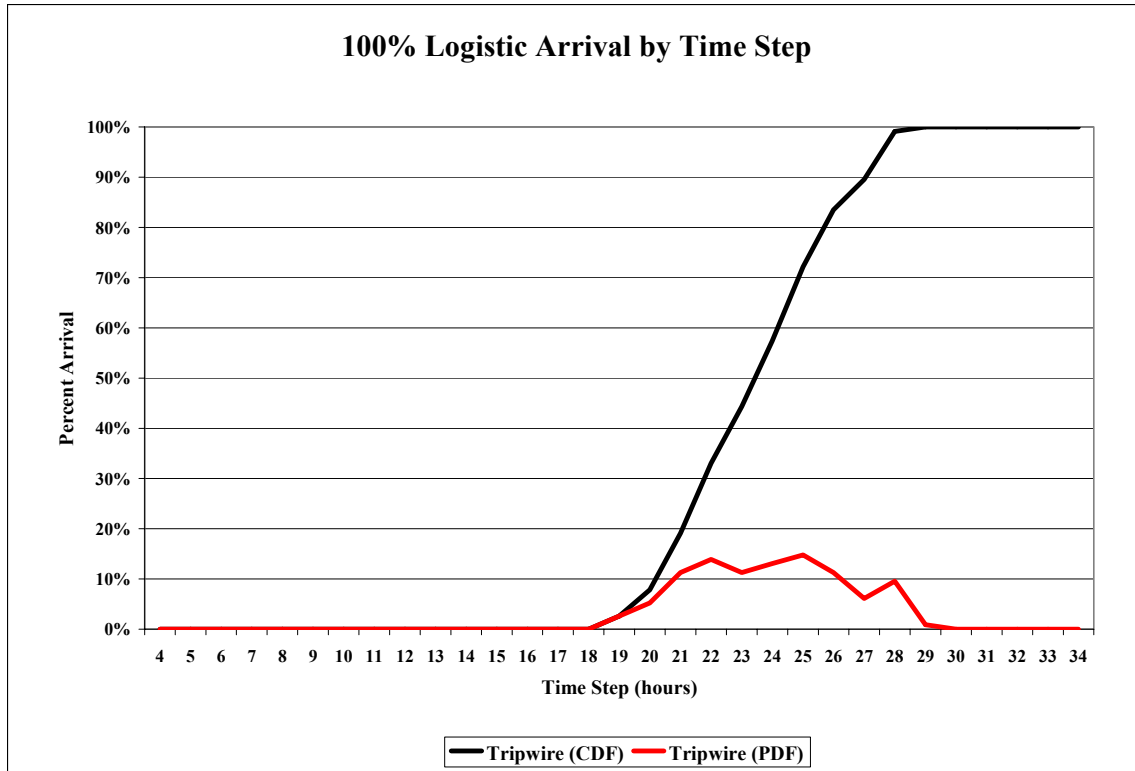
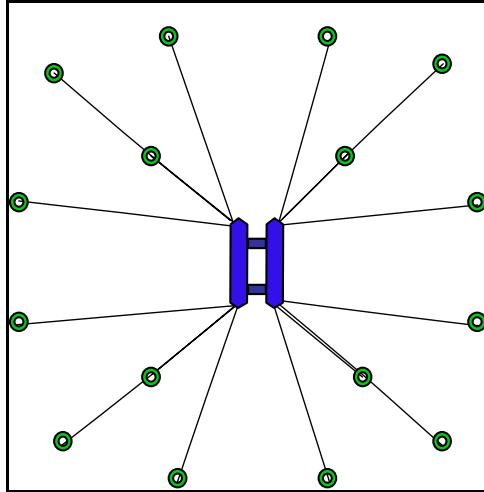


Figure 82: Tripwire – Logistical Arrival

3.4.2.5.2 ALTERNATIVE 2: TSSE Sea TENTACLE. Alternative 2, TSSE Sea TENTACLE, provides a capability of deploying organic underwater sensor into the AOR from locations outside the AOR. Although this was not designed specifically to be a clandestine alternative, a level of detection avoidance has been achieved in this scenario. The deployed assets transit into the AOR and construct an elaborate sensor grid on the sea floor. The successful deployment of the SoS must occur within the first 240 hours or 10 days of operations in order to serve as a viable alternative to the overarching problem presented to SEA-8.

No air superiority will exist. The mean transit time of the Sea TENTACLE ships was held constant at 6 days from the mean of the triangular distribution of all surface- and subsurface-deployed assets. Once on station, Sea TENTACLE will deploy its network of UUVs in order to establish a sensor grid. This grid will be the mainstay of detection ability in this alternative. The network hub pictured in Figure 83 is envisioned to cover a 10 NM x 10 NM area. A total of 70 of these hubs will be deployed to provide coverage of a 70 NM x 100 NM area.



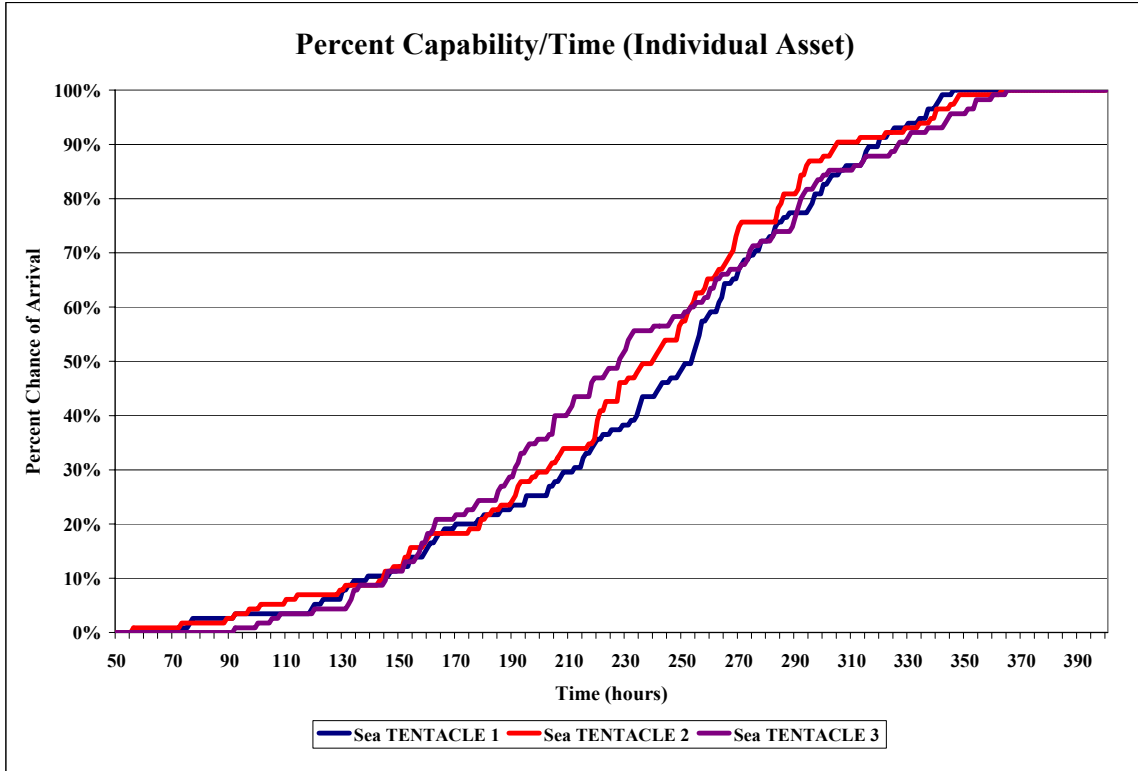
**Figure 83: TSSE Sea TENTACLE Sensor Grid**

**REQUIRED ASSETS:** Table 10 depicts sensor assets required and the deployment assets necessary to deploy them.

Deployment Assets	Deployment Location	Sensor Assets Deployed to Achieve 96% FMC	Mean Transit Time (hours)	Mean Deployment Time (hours)
Sea TENTACLE 1	Deployed/ U/W	48 Large UUVs, 48 HWV UUVs 240 LWV UUVs, 640 man-portable	256.4	22
Sea TENTACLE 2	Deployed/ U/W	48 Large UUVs, 48 HWV UUVs 240 LWV UUVs, 640 man-portable	256.4	22
Sea TENTACLE 3	Deployed/ U/W	48 Large UUVs, 48 HWV UUVs 240 LWV UUVs, 640 man-portable	256.4	22

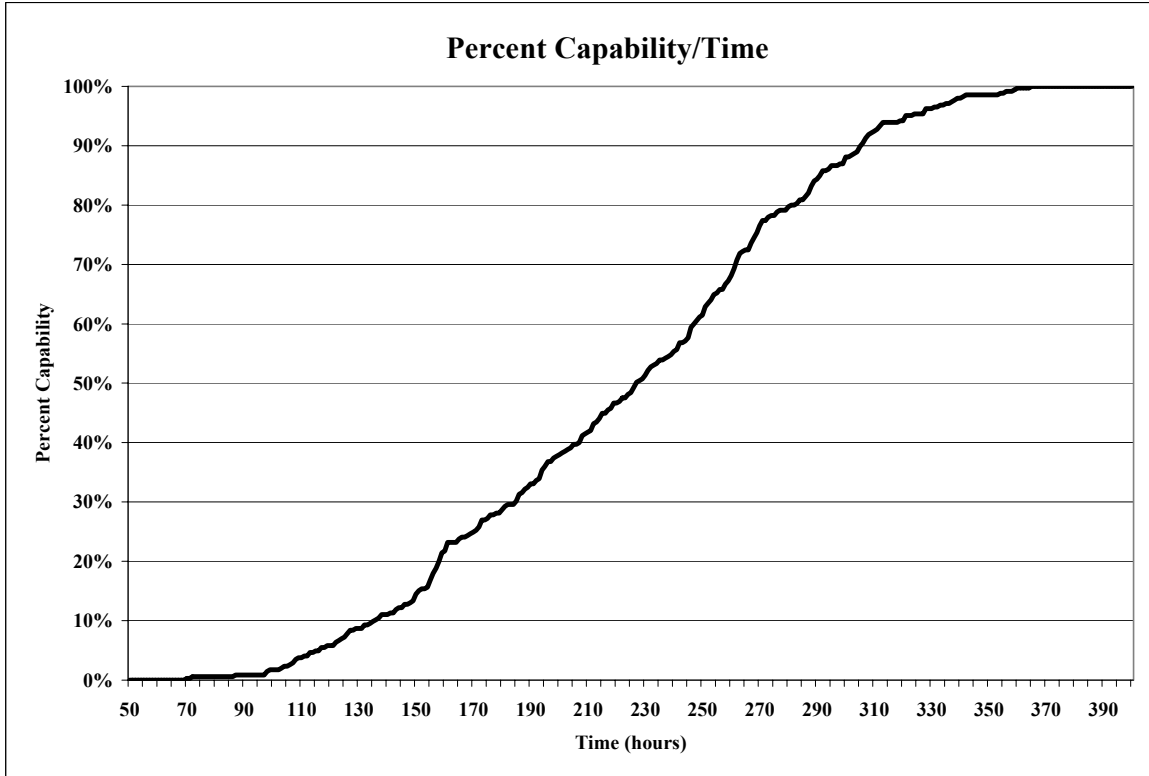
**Table 10: TSSE Sea TENTACLE Assets**

**MODELING OUTPUT:** Output data was modeled in an identical manner to that of Alternative 1. Figure 84 depicts percent capability available to the combatant commander over time for each of the three Sea TENTACLE ships involved with Alternative 2 (Tripwire Alternative).



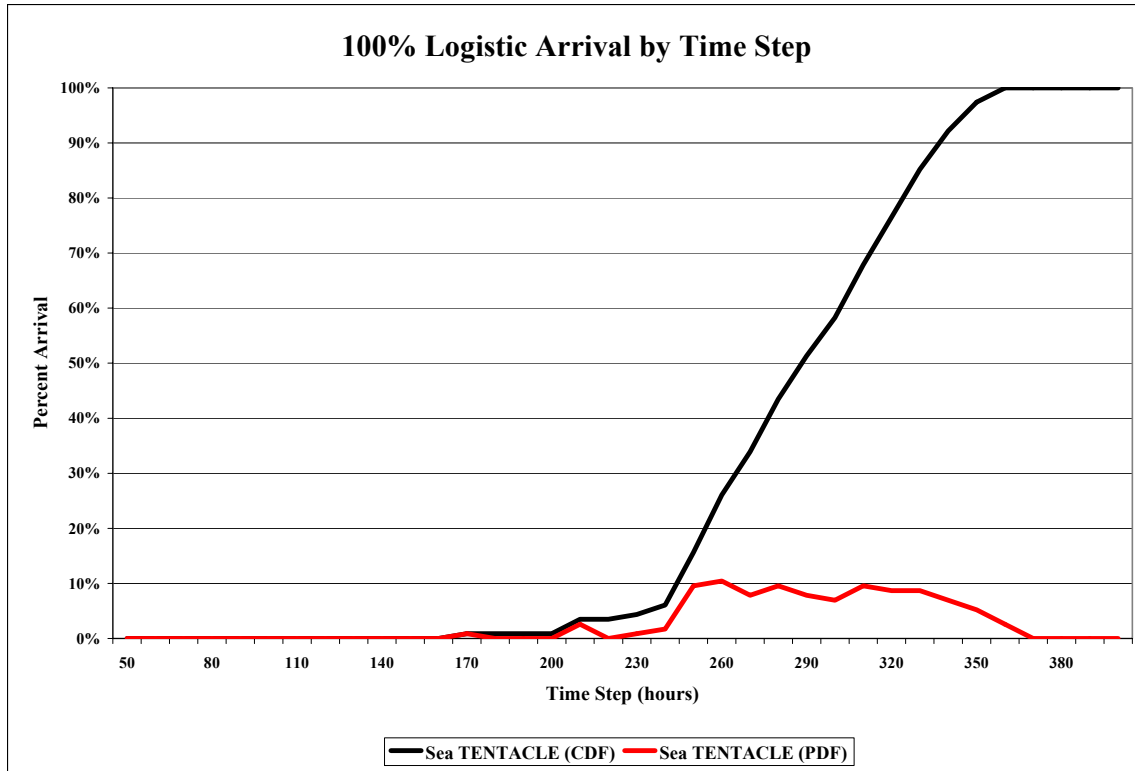
**Figure 84: TSSE Sea TENTACLE – Individual Percent Capability/Time**

The data recorded and modeled for each of the three Sea TENTACLE ships above was combined and presented in Figure 85 to display cumulative performance.



**Figure 85: TSSE Sea TENTACLE – Combined Percent Capability/Time**

The occurrence of all sensor components arrival in theater (Y-axis) by a certain time step (X-axis) is depicted in Figure 86. For example, 50% of the time, all assets will arrive in the AOR by hour 310, or 100% of the time, all assets will arrive in the AOR by hour 440.



**Figure 86: TSSE Sea TENTACLE – Logistical Arrival**

3.4.2.5.3 ALTERNATIVE 3: WAR OF MACHINES.

Alternative 3, War of Machines, provided an alternative that was capable of deploying sensor assets within the first 24 hours. The use of clandestine, high-altitude deployment methods take into consideration the assumed lack of air superiority. Marked differences of note exist between this alternative and that of Alternative 1 (Tripwire), the most important being the introduction of recharging stations. Recharging stations will provide the necessary power to sustain an adequate number of UUV assets over a 30 day period, which, in turn, will provide sensor coverage for a Pd of 0.8. Additionally, a tremendous increase from 15 HWV UUVs required to 51 can be found. This is in response to the exclusion of sea-web sensor components during this alternative. It should be restated that because 51 HWV UUV are required to begin the scenario, an FMC rating of 96% will require an additional 2 UUVs to be on-loaded and deployed to allow for failure in deployment.

**REQUIRED ASSETS:** Table 11 depicts the sensor assets required and the assets necessary to deploy them.

Deployment Assets	Deployment Location	Sensor Assets Deployed to Achieve 96% FMC	Mean Deployment Time to Achieve Sustainment (hours)	Deployment Time (hours)
B-52	Guam	10 HWV UUVs	8	0.1
B-52	Guam	10 HWV UUVs	8	0.1
B-2	Whiteman AFB	5 HWV UUVs	20	0.1
B-2	Whiteman AFB	5 HWV UUVs	20	0.1
B-2	Whiteman AFB	5 HWV UUVs	20	0.1
B-2	Whiteman AFB	5 HWV UUVs	20	0.1
B-52	Saipan	10 HWV UUVs	20	0.1
B-52	Saipan	10 HWV UUVs	26	0.1
SSGN	Deployed/ U/W	12 (UUVs) Recharging Stations	120	24

**Table 11: War of Machines Assets**

**MODELING OUTPUT:** A total of 8 air assets (4 B-2s and 4 B-52s) were strategically deployed and arrived in the AOR over a 40-hour period. The overarching goal of the War of Machines was to provide a robust and sustained alternative, one which would not fail once the power supply was expended. A reliability model was constructed and run apart from the deployment model. The results concluded that a total of 12 recharging stations would be required to recharge all operating UUVs. Due to the components, shape, and size of a recharging station, air deployment was not considered a viable deployment method.

An SSGN from a nearby CSG, LAG, or ESG would be capable of providing clandestine deployment. However, based on the triangular distribution of surface/subsurface assets, these recharging stations would not become available for a minimum of 144 hours or 6 days (mean). Additionally, it was found that when operating these UUVs, even with recharge, some would eventually fail for any number of reasons. In order to maintain greater than 41 HWV UUVs in the AOR, subsequent deployments would be required. Two additional air deployments would be made; 10 additional UUVs at hour 20, and another 10 UUVs at hour 26.

Of particular note, *near* 100% capability was achieved within 24 hours. However, because a mean of 144 hours was estimated for the SSGN to arrive with recharging stations, *actual* full capability cannot be fully assumed until this time. To fully understand the model results, Figures 87-89 have been constructed to illustrate percent capability within B-2 and B-52 aircraft only as well as percent capability of all assets.

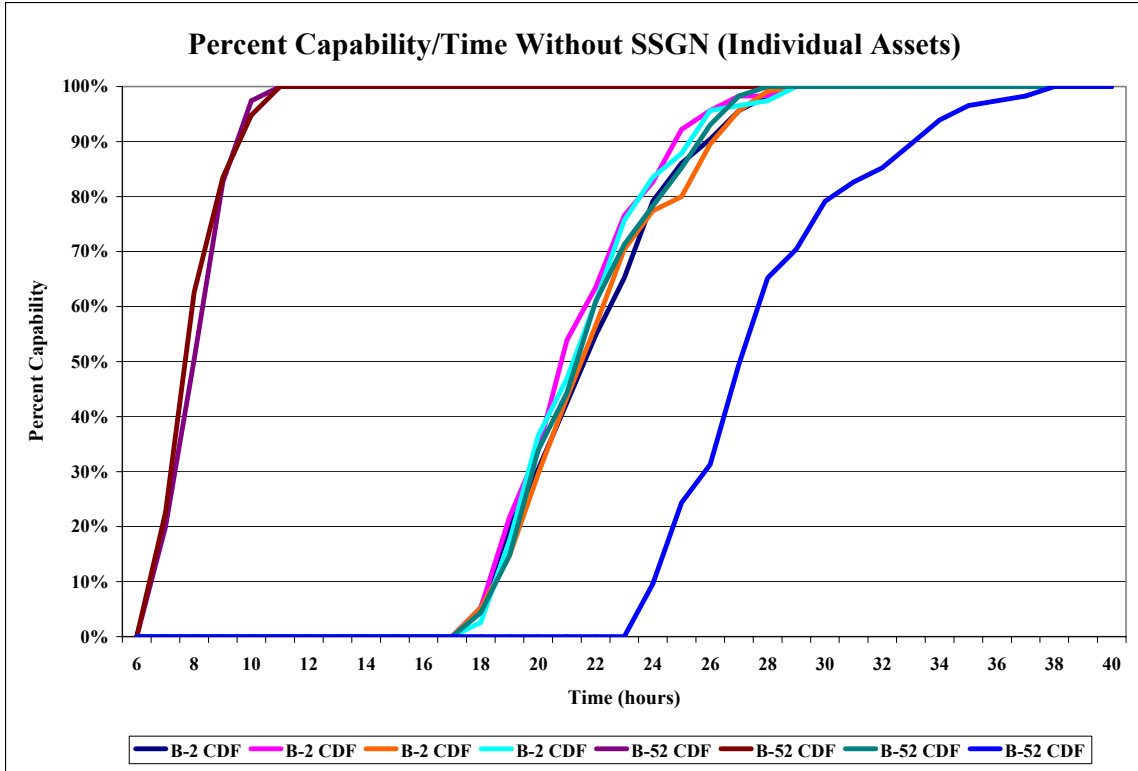


Figure 87: War of Machines – Aircraft Percent Capability/Time

Figure 88 illustrates percent capability of this alternative with B-2 and B-52 aircraft including the SSGN. After more than 115 iterations of the model, the SSGN arrived as recent as 107 hours and as late as 317 hours with a mean of 169 hours.



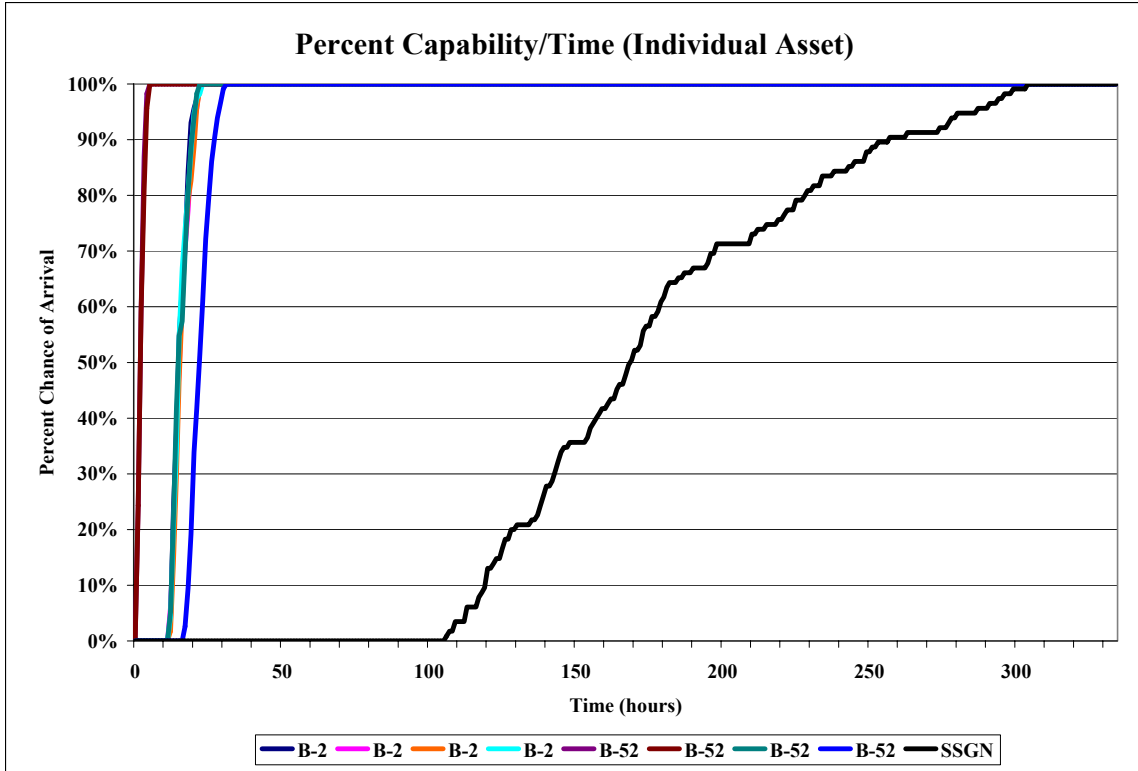


Figure 88: War of Machines – Aircraft and SSGN Percent Capability/Time

Figure 89 illustrates percent capability results that are combined for all assets. Modeling this alternative with 115 iterations produced an average result of 95% capability by hour 35.

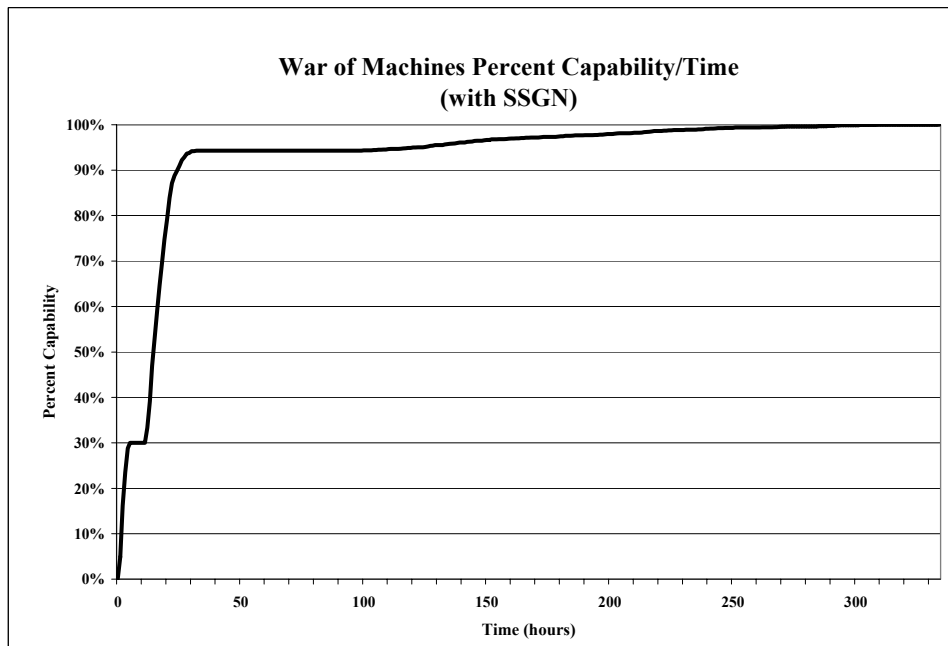


Figure 89: War of Machines – Combined Percent Capability/Time

To clearly illustrate modeling results, the CDF and PDF is captured and displayed for aircraft only (Figure 90) and total assets (Figure 91).

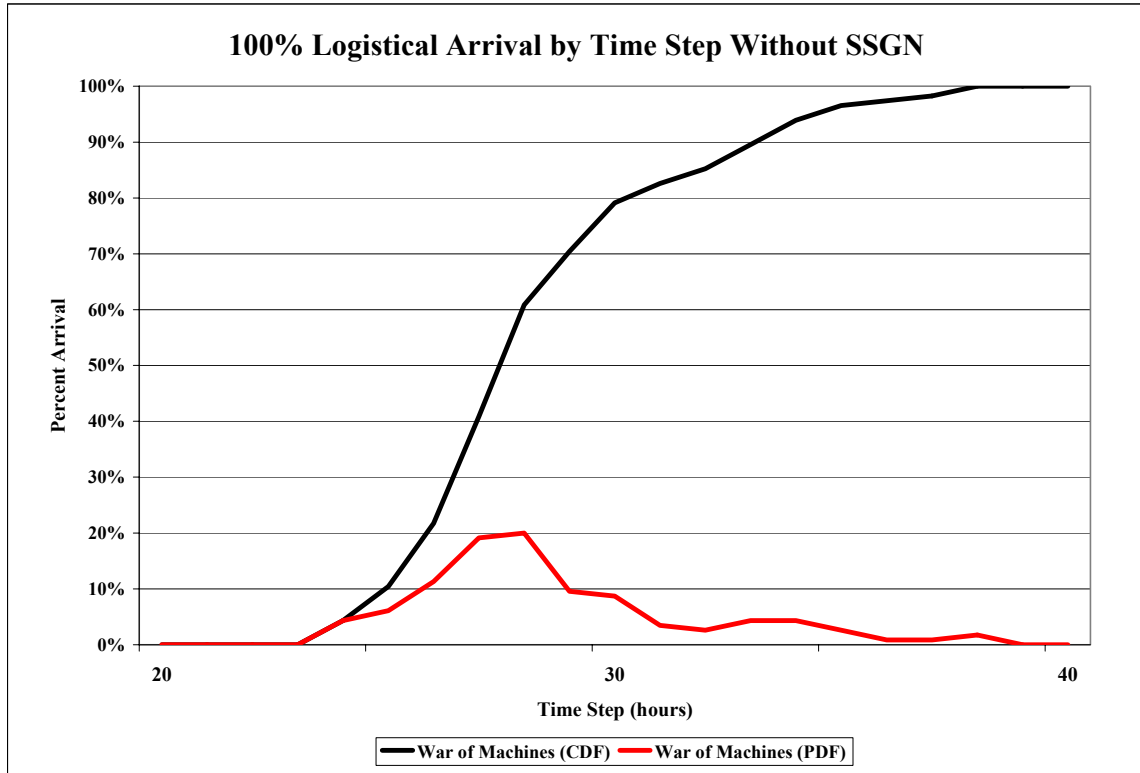
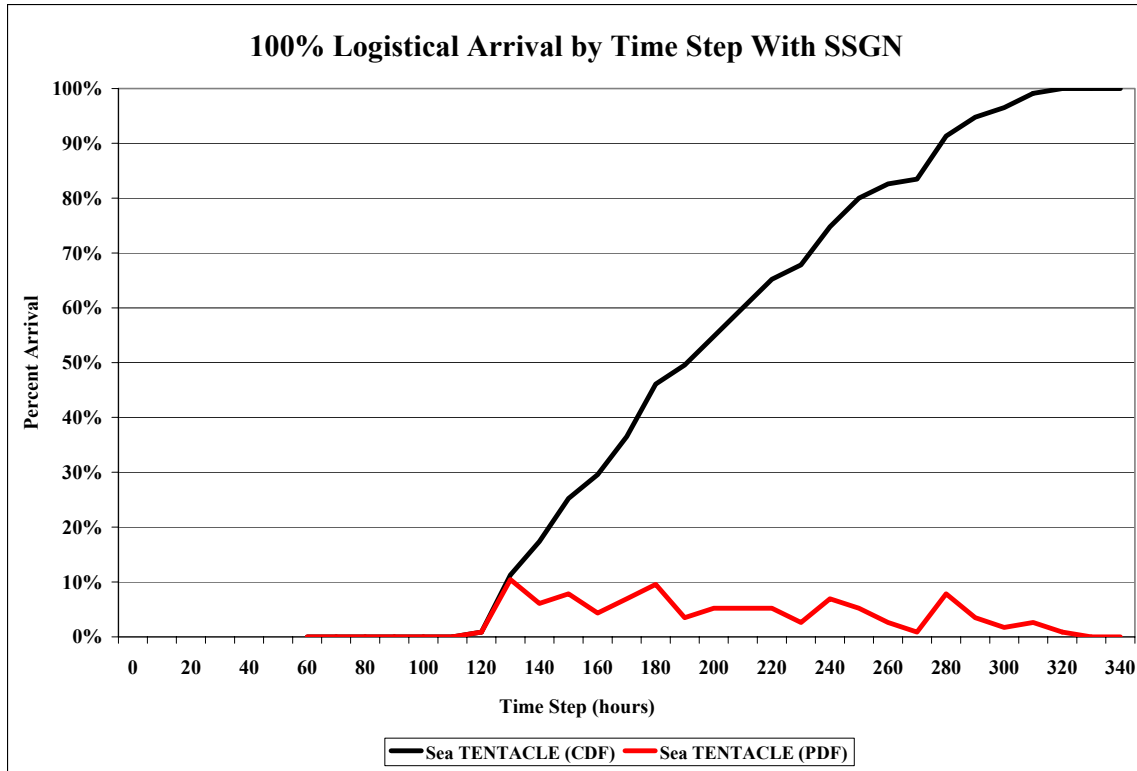


Figure 90: War of Machines – Aircraft Logistical Arrival Without SSGNs



**Figure 91: War of Machines – Total Asset Logistical Arrival Including SSGNs**

3.4.2.5.4 ALTERNATIVE 4: LAG. Alternative 4, LAG, utilizes a blend of conventional and future assets to conduct ASW. The LAG, comprised of surface ships and submarines outlined on the next page, will transit to the leading edge of the AOR, executing the alternative utilizing primarily organic sensors. LAG assets, however, are capable of carrying significant payload into the area in the form of additional sensor assets such as UUVs, USVs and UAVs. When the LAG is approximately 500 NM away from the AOR, SSN assets will close the rest of the distance at maximum speed, providing ASW protection for surface ships. The LAG, due to its surface ship composition, is considered the second of the overt alternatives.

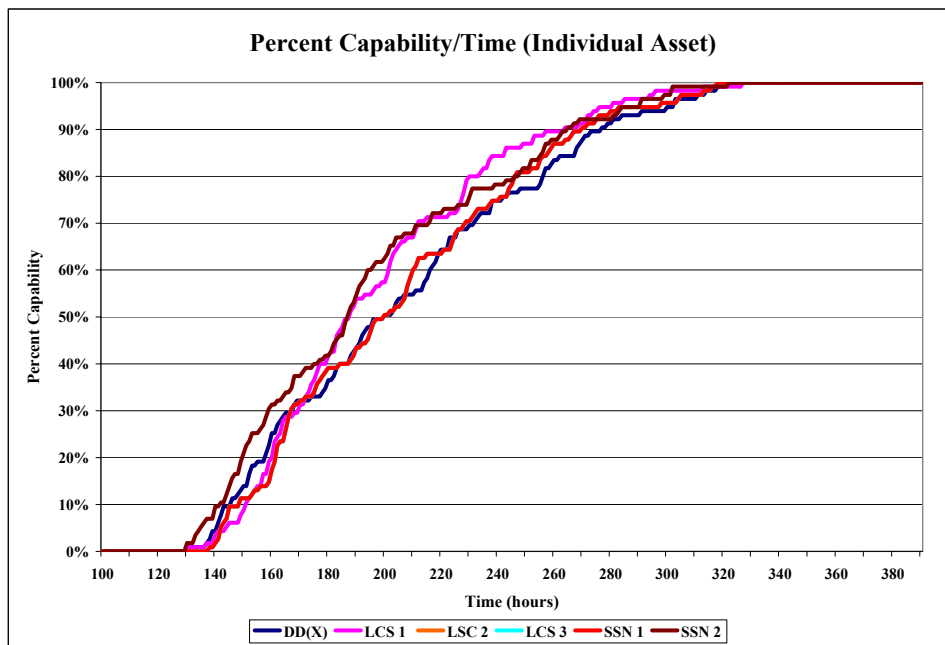
**REQUIRED ASSETS:** Table 12 depicts sensor assets required and the deployment assets necessary to deploy them.

Deployment Assets	Deployment Location	Payload Capability (tons)	Mean Transit Time (hours)	Deployment Time (hours)
DD(X)	Deployed/ U/W	6	144	N/A
LCS 1	Deployed/ U/W	40	144	N/A
LCS 2	Deployed/ U/W	40	144	N/A
LCS 3	Deployed/ U/W	40	144	N/A
SSN 1	Deployed/ U/W	6	144	N/A
SSN 2	Deployed/ U/W	6	144	N/A
N/A = Not Applicable.				

**Table 12: LAG Assets**

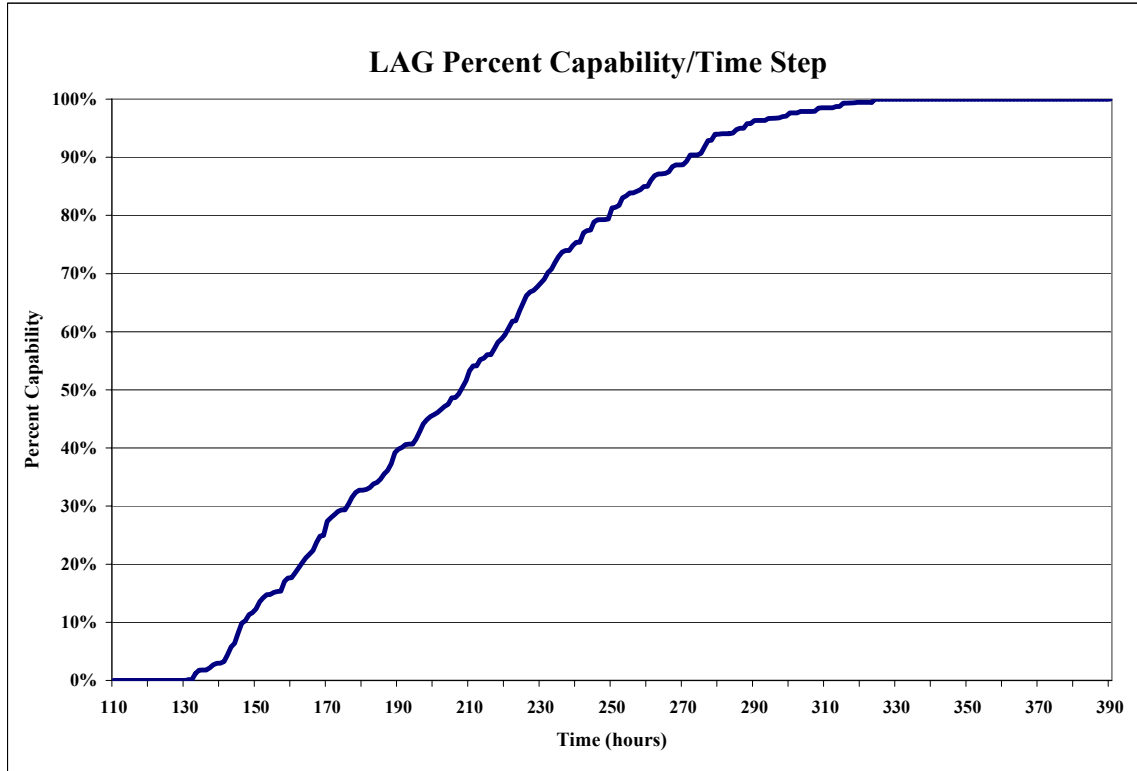
**MODELING OUTPUT:** Output data of specific value was recorded for further analysis. The CDF and the PDF of the 115 iterations of arrival times were again some of the most valuable data when comparing alternatives. All LAG assets were modeled with a mean transit time of 144 hours, with the exception of submarines, which were modeled with a mean transit time of 120 hours.

LAG assets achieve 100% capability immediately on arrival to the AOR through utilization of organic assets. During this time, assets may deploy additional off-board sensors in accordance with the payload capability totals listed in Table 12. Figure 92 depicts the percent capability over time for LAG assets, including submarines.



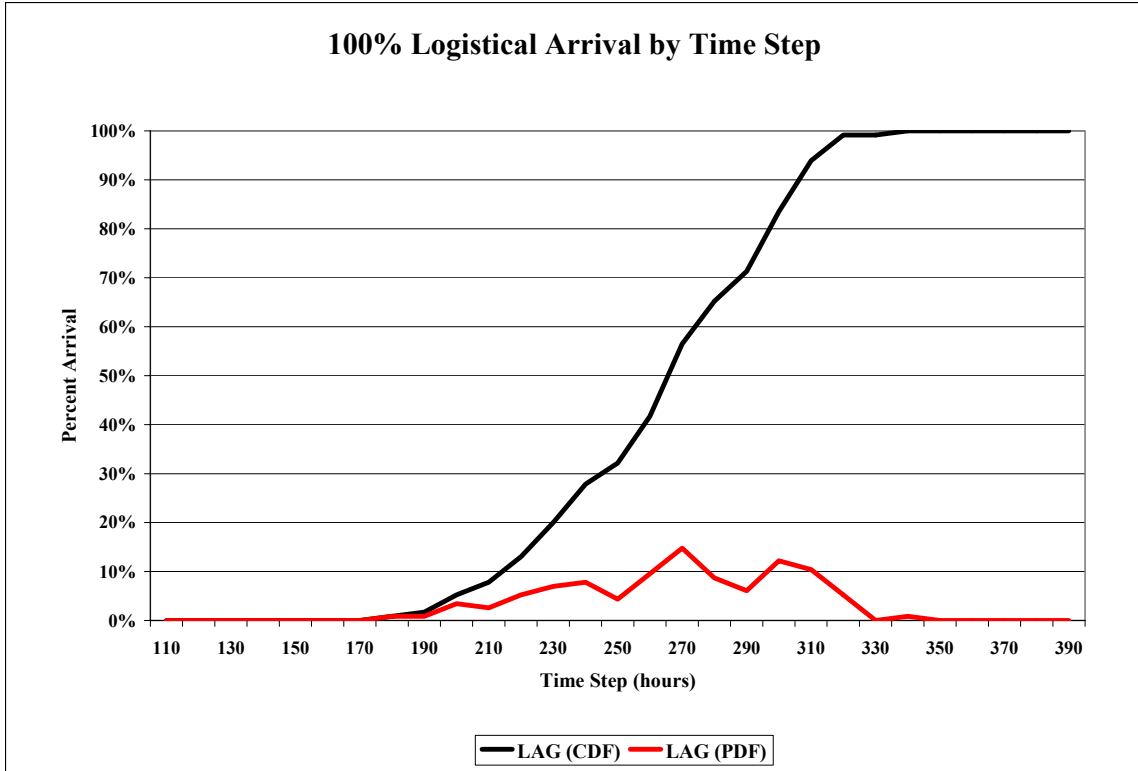
**Figure 92: LAG – Individual Percent Capability/Time Step**

Figure 93 illustrates the combined percent capability over time step. Through the triangular distribution utilized, LAG assets arrive as recent as 130 hours and as late as 328 hours with a mean of 192 hours.



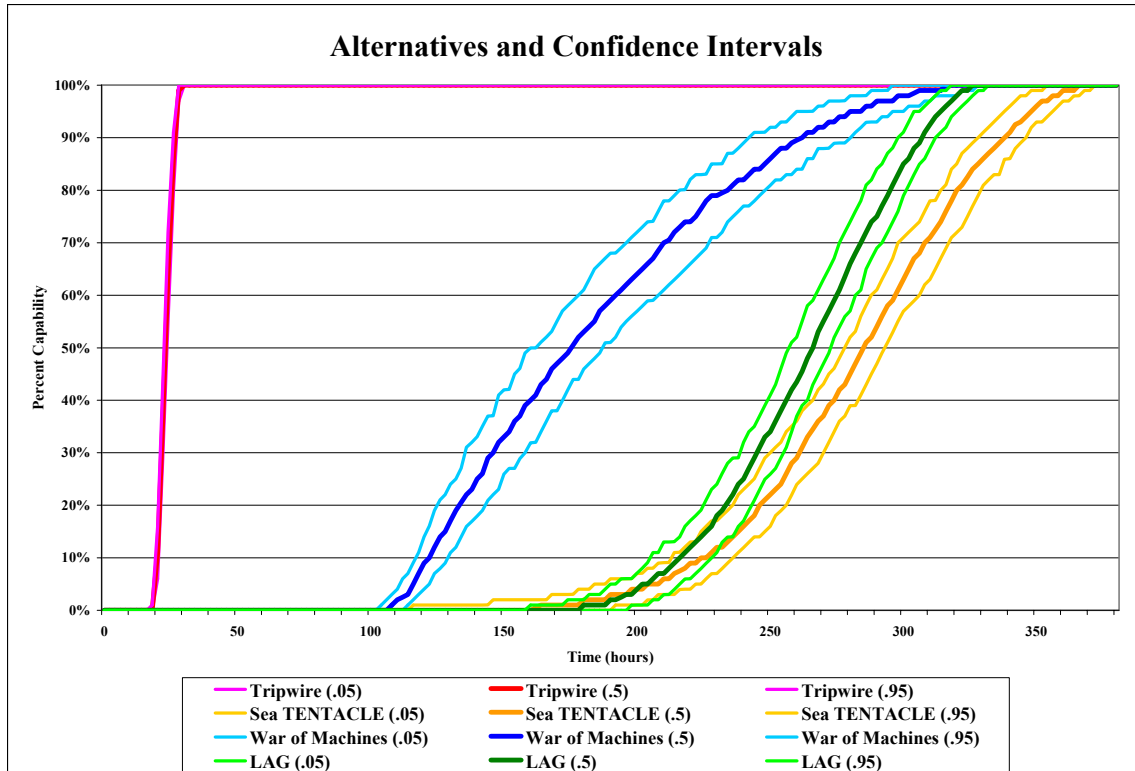
**Figure 93: LAG – Combined Percent Capability/Time Step**

Finally, 100% logistical arrival of the LAG is illustrated in Figure 94. The CDF, represented in blue, depicts the percent chance of total asset arrival over time, while the PDF, represented in red, illustrates the probability of the arrival occurring at the specific time step. Lengthy transit times, coupled with a wide maximum and minimum arrival time in the triangular distribution, is the likely cause for the variance in the PDF.



**Figure 94: LAG – Logistical Arrival**

3.4.2.5.5 MODELING OUTPUT AND OVERLAYS OF ALTERNATIVES. Once all data was recorded and analyzed separately for each individual alternative, the CDF for each was then captured, compared, and contrasted. A 90% confidence level was constructed about the mean to illustrate variability within each alternative as compared to the other alternatives. Figure 95 depicts the mean CDF, an upper confidence bound, and a lower confidence bound for each alternative.



**Figure 95: Alternative Confidence Intervals**

Figure 91 represents the distinct data output of each alternative when considering their deployment. The greater the area between the closest confidence bound of a competing alternative, the greater the military significance difference between them could be. When an overlap occurs, this may indicate potentially little difference in competing deployment alternatives.

### 3.4.3 Prosecution Modeling

This section addresses the goals established in the Objectives Hierarchy and how the research or modeling satisfied the achievement of those goals, as listed below:

- For Assess: 100% accuracy of environmental data
- For Search and Detection: 100% coverage within 24 hours of assets on station with an 80% RMP for the coverage factor (confidence) MOP and a Pd of 0.8 (80%)
- For Tracking: Track long enough to classify or satisfy ROE and obtain a fire control solution, if necessary

### 3.4.3.1 Assess

The Assess portion of the Objectives Hierarchy deals strictly with the environmental (oceanographic and atmospheric) assessment and forms part of the “battlespace preparation and monitoring” aspect of the original problem statement. The ASW equation relies heavily on a keen understanding of the environment.

Sonar performance predictions [today] are based on a set of assumptions that attempt to describe the oceanography, bottom and sea surface conditions of the environment under consideration. Thus, performance is often predicted with idealized inputs (e.g., direction-independent sound speed profiles, or horizontally isotropic bottom properties).<sup>156</sup>

The environment is what determines how far, and in what direction, sound travels underwater. Without this understanding, sonar operators and data processors would not be able to determine the characteristics of sound that is detected underwater. A lack of understanding of the environment can be a major contributor to reduced detection and increased false alarm rates. Understanding the environment is also one of the three key issues listed below that, when addressed, help the operational commander understand the problem described in the Needs Analysis section:

1. The environment: an understanding and a good predictability of the environment will greatly assist with the detection and classification of enemy submarines and UUVs
2. 2025 sensor technology: knowing what will be available, what technological improvements have occurred, and how processing has improved over time—all of which will aid in the timely detection of enemy submarines and UUVs
3. The target will be impossible to find unless the operational commander and technical operators and system users know what they are looking for, how to detect it, what are its counter measures, what tactics they use, etc.

---

<sup>156</sup> Philip Abbot and Ira Dyer, (2002), “Sonar Performance Predictions Incorporating Environmental Variability,” *Ocean Acoustical Services and Instrumentation Systems (OASIS), Inc.*



### 3.4.3.1.1 ENVIRONMENTAL ASSESSMENT.

Peter Nielsen et al., state that

...successful sonar performance predictions in shallow-water regions are strongly dependent on accurate environmental information used as input to numerical acoustic prediction tools. The sea-surface and water-column properties vary with time and this time variability of the ocean introduces fluctuations in received acoustic signals. The lack of knowledge of the environmental changes results in uncertainty in predictions of the acoustic propagation.<sup>157</sup>

Several means exist to search for, detect, track, and classify enemy underwater forces. While the most common method is by intercepting and analyzing underwater noise or sounds, other methods also include visual, radar, electromagnetic, infrared, laser, and satellite imagery. Acoustics is the most common science used today, but that should not limit our forces from other means of discovery.<sup>158</sup> If properly resourced, new technologies will exist in 2025 that will support friendly forces and provide the ability to quickly detect an underwater enemy asset in the required time.

**ACOUSTICS:** A thorough understanding of underwater acoustics is necessary in order to analyze the results in the modeling effort. CDR Rebecca Stone, Professor of Meteorology at the Naval Postgraduate School in Monterey, CA, summarized what affects sound travel underwater: (a) sound velocity profiles (SVP); (b) bottom composition (loss on bounce); (c) weather; and (d) internal waves (about 3%). All four of these effects will be analyzed below.

The sound speed within a water column changes as a result of temperature, pressure, and salinity. As the sound speed increases, it is as a result of an increase in the temperature, pressure, and/or salinity. Modeling tools used to determine accurate environmental data are extensive, but they are not comprehensive.<sup>159</sup> These tools help the sonar or ASW sensor operator understand the intricacies of sound propagation,

---

<sup>157</sup> Peter L. Nielsen, Martin Siderius, and Jurgen Sellschopp, (2002), "Broadband Acoustic Signal Variability in Two 'Typical' Shallow-Water Regions," *SACLANT Undersea Research Center*.

<sup>158</sup> John R. Potter, "Challenges of Seeing Underwater—A Vision for Tomorrow," Acoustic Laboratory Research, Electrical Engineering Department and Tropical Marine Science Institute, National University of Singapore, <http://arl.nus.edu.sg>.

<sup>159</sup> Paul C. Etter, (1991), *Underwater Acoustic Modeling: Principles, Techniques and Applications*, London, Elsevier Science Publishers, p. 4.

and provides a predictor of range and frequency of the signal received—data which helps noise processing systems identify underwater targets.

The analysis of sound velocity underwater (resulting in SVPs) is a common measurement used to predict sonar ranges. The most commonly used tool today is the expendable bathythermograph sonobuoy (XBT). This device measures sound speed by comparing temperature and depth variables. In the XBT calculations of sound speed it is assumed that the “typical range of salinity in the open ocean is usually small and that the corresponding impact on sound speed is negligible from a practical standpoint.”<sup>160</sup> By assuming that the salinity is constant, it invalidates the use of XBTs for littoral region sonar predictions. A more accurate predictor of sound velocity underwater is the Velocimeter, which “measures sound speed directly in terms of travel time of sound over a constant length fixed path.”<sup>161</sup> This method is more accurate for the littorals, but its use is not as common today as the XBT.

Shallow water, fixed-path, sound (acoustic) propagation is affected by three environmental factors: “tidal effects, water-column sound-speed fluctuations, and scattering from bathymetry and seabed.”<sup>162</sup> Shallow-water sound profiles show that the sound waves refract downward causing “significant bottom interaction.”<sup>163</sup> Turgut ascertains that “active and passive sonar systems [are] strongly influenced by [the] interaction of acoustic energy and the seabed,” and that proper knowledge of seabed properties (compressional wave speed, attenuation, density structure) is required in order for the sonar systems to perform their predictions accurately.<sup>164</sup>

Acoustic or statistical models can be used to predict sound behavior in shallow water, but acoustic data will show significant variability (“sudden increases in [transmission loss] at particular frequencies, amplitude fading and arrival-time variability of received time series”) that is caused by oceanographic conditions

---

<sup>160</sup> Ibid.

<sup>161</sup> Ibid.

<sup>162</sup> Peter L. Nielsen, Martin Siderius, and Jurgen Sellschopp, (2002), “Broadband Acoustic Signal Variability in Two ‘Typical’ Shallow-Water Regions,” *SACLANT Undersea Research Center*.

<sup>163</sup> Kevin D. Lepage, (2002), “Modeling Propagation and Reverberation Sensitivity to Oceanographic and Seabed Variability,” *SACLANT Undersea Research Center*.

<sup>164</sup> Turgut et al., (2002), “Measurements of Bottom Variability During SWAT New Jersey Shelf Experiments,” *Office of Naval Research, Naval Research Laboratory*.

(internal waves) over time.<sup>165</sup> Models used to predict SVPs in shallow water, however, require accurate “high fidelity acoustic models that compute realizations of propagation or reverberation over a sample of oceanographic or bottom variability.”<sup>166</sup> Bottom variability affects sound propagation. Database performance predictions in shallow water are unreliable (with the weakest link being the bottom-loss information).<sup>167</sup>

A chirp sonar survey can provide accurate subbottom features (seafloor roughness) such as “marine/non-marine erosional subsurface, buried river channels, erosional channels, sand ridges, and iceberg scours... geological and oceanographic features that might influence acoustic wave propagation in the area.”<sup>168</sup>

Weather is also an influence on sound propagation underwater. Sea surface affects underwater sound by creating the following uncertainty effects:

- forward scattering and reflection loss;
- image interference and frequency effects;
- attenuation by a layer of bubbles;
- noise generation at higher frequencies due to surface weather; and
- backscattering and surface reverberation<sup>169</sup>

These uncertainties (affected by wave height that is wind dependent), however, can be incorporated into mathematical models by specifying boundary conditions that can range from simple to complex (depending on model sophistication).<sup>170</sup> Once these inputs have been modeled and a prediction established, however, internal tides, wind, tidal currents, and river outflow all create instabilities that cannot be accurately accounted for in the model and erase the model’s ability to predict

---

<sup>165</sup> Ibid.

<sup>166</sup> Kevin D. Lepage, (2002), “Modeling Propagation and Reverberation Sensitivity to Oceanographic and Seabed Variability,” *SACLANT Undersea Research Center*.

<sup>167</sup> Carlo M. Ferla and Finn B. Jenses, (2002), “Are Current Environmental Databases Adequate for Sonar Predictions in Shallow Water,” *SACLANT Undersea Research Center*.

<sup>168</sup> Turgut et al., (2002), “Measurements of Bottom Variability During SWAT New Jersey Shelf Experiments,” *Office of Naval Research, Naval Research Laboratory*.

<sup>169</sup> Paul C. Etter, (1991), *Underwater Acoustic Modeling: Principles, Techniques and Applications*, London, Elsevier Science Publishers, p. 51.

<sup>170</sup> Ibid.

sound propagation.<sup>171</sup> Numerical models are also “hydrostatic, and cannot account for steep topography effects and small-scale internal waves.”<sup>172</sup>

The following quote from Paul C. Etter accurately describes the problems faced today in our understanding of underwater acoustics in shallow-water regions (littorals):

Because of the wide range of acoustic frequencies, ocean areas and geometries of interest to researchers, it is virtually impossible to accommodate all observational requirements within normal fiscal constraints. To make matters worse, acoustic data are sometimes collected at sea without the supporting oceanographic data; thus models cannot always replicate the observed acoustic results because they lack the necessary input parameters for initialization. Satellites, together with other remote sensing techniques, provide a useful adjunct to the prediction of underwater acoustic conditions. Specifically, many dynamic features of the ocean affect the behavior of sound, and knowledge of their location can improve the prediction of sonar performance.<sup>173</sup>

**2025 SENSOR TECHNOLOGY:** The most commonly used sensors that are readily available for environmental assessments are limited to open-ocean environments. As we get closer to shore, new developments in technology are coming to light that show how our perception of a constant underwater environment is incorrect. Several systems today (whether proposed or in a testing phase) assess the environment as needed and frequently to provide accurate inputs into sonar and underwater sound equations, providing an increased probability of detection and a greater reduction in false-alarm rates, and they are:

- A proposed “around the ship modeling system” that would assess at a local level the “initial phase uncertainty of the freely propagating modes and include the oceanographic field estimates and the evaluation of uncertainty error bounds on the sound speed profile estimates. These results can then be used on transmission loss models for a more robust

---

<sup>171</sup> Emanuel Coelho, (2002), “Mesoscale - Small Scale Oceanic Variability Effects on Underwater Acoustic Signal Propagation,” *SACLANT Undersea Research Center*.

<sup>172</sup> Ibid.

<sup>173</sup> Paul C. Etter, (1991), *Underwater Acoustic Modeling: Principles, Techniques and Applications*, London, Elsevier Science Publishers, p. 4.

[active sonar detection range].”<sup>174</sup> This method assimilates data into numerical models in order to provide a snapshot sound-speed cross section that feeds into transmission loss models. Using such a modeling system would allow ships to have up-to-date (within minutes) knowledge of the water column and provide a more accurate prediction of sonar ranges.

- Rapid Environmental Assessment (REA) is another strategy that can help optimize the active sonar detection range estimate by providing forecast data that is consistent with real-time environmental conditions. Several drawbacks exist with this option,<sup>175</sup> but combined with other assets, REA may prove to be useful in building full models that determine environmental data more accurately.
- NATO Tactical Ocean Modeling System (NTOMS) is an ocean variability model that takes into consideration “historical data, regional models analysis and forecasts and remote sensing data.”<sup>176</sup> This statistical model acts as an interface between local, observed, environmental data and models created to resemble regional data. New measurements at the local level update regional models and provide a method of predictability so as to eliminate point observations. Regional models estimate sound-speed cross sections between two consecutive points that cross an internal wave field. “This model is set to run based on initial profiles estimated through XBT’s or other similar instruments and then uses wavelength information interpreted either from actual or historical SAR imagery.”<sup>177</sup>
- Wesley Jordan, in “Moving Forward in ASW,” proposes dispensing “small calibrated targets in known, fixed positions around the area so that sensor operators could directly observe performance.”<sup>178</sup> Replacing the

---

<sup>174</sup> Emanuel Coelho, (2002), “Mesoscale - Small Scale Oceanic Variability Effects on Underwater Acoustic Signal Propagation,” *SACLANT Undersea Research Center*.

<sup>175</sup> REA strategies “cannot account accurately for all high frequency oceanographic phenomena... cannot produce accurate snapshots of the sound-speed profiles to be used into the transmission loss models... cannot account for steep topography effects and small scale internal waves.” *Ibid*.

<sup>176</sup> *Ibid*.

<sup>177</sup> *Ibid*.

<sup>178</sup> Wesley E. Jordan, “Moving Forward in ASW,” *Sea Technology*. 38, No. 1 (January 1997): pp. 53-56.

current prediction aspect of ASW with actual and frequent direct observations would eliminate the need to infer actual performance of underwater detection devices through the observation of independent variables such as salinity and temperature. Advantages include: (1) “the observation accounts not only for current environment alertness and proficiency effect, but also for the state of the equipment and the individual operators”; (2) “the ability of operators to get frequent feedback should help maintain alertness”; and (3) “commanders have the opportunity to obtain in real time the overall search effectiveness and to develop search plans based on an empirical observed ‘range of the day’.”<sup>179</sup> In addition to the three advantages just mentioned, this proposal could mean an improvement in the near-term by “providing the capability to collect range-dependent data in operational environments which can be used for local-area guidelines and to guide future sensor upgrades.”<sup>180</sup>

- The use of autonomous probes such as the Shallow Water Expendable Environmental Profiler (SWEEP), Ocean Sensors’ Autonomous Profiling Vehicle (APV), or the moored Portable Ambient Noise Data Acquisition (PANDA) would “widen the scope for multi-platform fusion and exchange, improved systems performance estimation and tactical decision making.”<sup>181</sup>

3.4.3.1.2 CONTRIBUTION OF ENVIRONMENTAL SENSORS TO THE OVERALL MISSION. The “Full Spectrum ASW Campaign Plan” presentation by CAPT Bill Toti, USN, provides a perspective on determining what contribution each ASW technology has on the overall ASW problem.

Figure 96 illustrates the areas considered for the mission capability assessment (MCA) metric that CAPT Toti uses to evaluate a technology’s contribution to the overall mission.

---

<sup>179</sup> Ibid.

<sup>180</sup> Ibid.

<sup>181</sup> John R. Potter, “Challenges of Seeing Underwater—A Vision for Tomorrow,” Acoustic Laboratory Research, Electrical Engineering Department and Tropical Marine Science Institute, National University of Singapore, <http://arl.nus.edu.sg>.

<b>Technology contributes to:</b>	<b>Baseline</b>	<b>Sample</b>
Prevent Diesel Submarine (SSK) from Leaving Port	0.00	
Defeat SSK in Port	0.02	
Defeat SSK Leaving Port	0.28	
Defeat SSK in Choke Point	0.30	
Open Ocean	0.05	
Make Red Go to the Wrong Place	0.20	
Defeat Red's Ability to Find Blue	0.15	0.15
Close ASW Fight	0.00	
Defeat Red's Attack	0.00	
<b>Total Technology Contribution</b>	<b>1.00</b>	<b>0.15</b>
<b>Environmental Multiple</b>		0.30
<b>Pd</b>		0.70
<b>Tactical Multiple</b>		
Operational Employability		0.45
<b>Risk Multiple</b>		
Chance of Technology Developed to Maturity		0.60
<b>Mission Capability Assessment</b>		0.0085

**Figure 96: MCA Metric with Baseline and a Sample Problem**

In the “Sample” column in Figure 96, the technology evaluated only contributes to the mission by defeating Red forces’ ability to find Blue forces. The area of concern in this case is the environmental multiple. If the environmental multiple is 100%, or 1 (as represented in Figure 97), the MCA is 3.34 times greater (from 0.0085 to 0.0284), thus increasing the impact the technology has on the mission. While this multiple can be determined by the Meteorological and Oceanographic Centers (METOC), increases will have to be determined by the technology reaching maturity, a greater probability of detection, and a higher operational employability—which may include being able to get the asset on station and the specific (modular) sensor attached in time for the operation to commence.

<b>Technology contributes to:</b>		<b>Baseline</b>	<b>Sample</b>
Prevent SSK from Leaving Port		0.00	
Defeat SSK in Port		0.02	
Defeat SSK Leaving Port		0.28	
Defeat SSK in Choke Point		0.30	
Open Ocean		0.05	
Make Red Go to the Wrong Place		0.20	
Defeat Red's Ability to Find Blue		0.15	0.15
Close ASW Fight		0.00	
Defeat Red's Attack		0.00	
<b>Total Technology Contribution</b>		<b>1.00</b>	<b>0.15</b>

<b>Environmental Multiple</b>	1.00
<b>Pd</b>	0.70
<b>Tactical Multiple</b>	
Operational Employability	0.45
<b>Risk Multiple</b>	
Chance of Technology Developed to Maturity	0.60
<b>Mission Capability Assessment</b>	0.0284

**Figure 97: Change Effected for MCA with Environmental Multiple at 1**

An increase in the environmental multiple can be achieved by using a mixture of diverse sensing technologies that improve environmental prediction. Figure 94 summarizes the options available for underwater environmental assessment and a highly subjective baseline that is based on a personal perspective on how effectively the technology can assess the environment since no real data exists that can attest to the actual performance of each of the sensors described in Figure 98.

<b>Environmental Multiple</b>	<b>Baseline</b>
Existing Database with Daily XBT Input	0.05
Around the Ship Modeling System	0.30
Rapid Environmental Assessment (REA)	0.25
NATO Tactical Ocean Modeling System (NTOMS)	0.05
Shallow Water Expendable Enviro Profiler (SWEEP)	0.10
Ocean Sensors Autonomous Profiling Vehicle (APV)	0.08
Portable Noise Data Acquisition (PANDA)	0.07
Satellite Imagery	0.10
<b>Total for Environmental Multiple</b>	<b>1.00</b>

**Figure 98: Parts that Comprise the Environmental Multiple**

Several things need to be taken into consideration when deriving the baseline multiple for each of the sensors listed in Figure 98. In these considerations, one may find the same items as those listed for the calculation of the MCA, including the



technology's maturity level, the ability to get the sensor into the operational theater in time, the sensing characteristics of each, etc.

If the technologies are developed and operational by 2025, and they can reach the operational theater when required, this will drive the environmental multiple close to 1, which satisfies the goal set forth in the Objectives Hierarchy of achieving 100% accuracy of environmental data. The next step is to evaluate the contact picture.

#### ***3.4.3.2 Search and Detection***

The Search and Detection objective ties in to the “persistent detection and cueing” aspect of the original problem statement. The following diagram is a comprehensive list of sensors available and outlines whether they are deployed or operate on space, air, surface, or subsurface platforms. Since the solution proposed to stray away from platform-centric methods, the individual platforms are not listed here.

While the list of sensors in Table 13 is large, some of the sensor systems listed are not yet in an operational state at the time of this study. The conventional radars, sonar systems, and standard towed arrays exist on air, surface, and subsurface vessels, but in the future, these systems should be modular enough to fit on most any air, surface, or subsurface platform (manned or unmanned) and operate autonomously throughout an operation.

Asset	Acronym	Space	Air	Surface	Subsurface
Advanced Distributed System	ADS			X	
Advanced Extended Echo Ranging	AEER		X		
Airborne Radar Periscope Detection & Discrimination	ARPDD		X		
Deployable Autonomous Distributed System	DADS		X	X	X
Dipping Sonar			X		
Electro-Magnetic	EM		X		
Electronic Warfare	EW			X	X
Electro-Optic Passive ASW Sensor	EPAS		X		
European Synthetic Radar Satellites	ERS	X			
High Gain Volumetric Array	HGVA			X	
Improved Extended Echo Ranging	IEER		X		
Infrared	IR		X		
Infrared Mode W	IR Mode W		X		
Large Wide Aperture Array	LWAA				X
Light Detection and Ranging	LIDAR		X		
Lightweight Broadband Variable Depth Sonar	LBVDS				X
Littoral Volumetric Acoustic Array	LVAA		X	X	X
Low Frequency Active Sonar	LFAS			X	
Magnetic Anomaly Detector	MAD		X		
Medium N Sensors	Medium N			X	
Mobile Off-Board Source	MOBS			X	
Multi-Function Towed Array	MFTA			X	
Near Term Multi-Line Towed Array	NTMLTA				X
Network Enabled Anti-Submarine Warfare	NEASW		X		
Parametric Sonar				X	
RADAR	Radar		X	X	X
Radar Augmentation for Periscope Identification	RAPID			X	
Receive While Transmit	RWT			X	
Reliable Acoustic Path Vertical Line Array	RAP VLA		X	X	X
Remotely Operated Mobile Ambient Noise Imaging System	ROMANIS			X	
Scalable Improved Processing Sonar	SIPS			X	
SONAR	Sonar			X	X
Sonobuoys			X		
Sound Surveillance System	SOSUS				X
Surface Towed Array Sonar System	SURTASS			X	
Unmanned Lightweight Towed Arrays	UTAS			X	
Visual			X	X	X
Visual Electro-Magnetic	Visual EM		X		

**Table 13: All-Inclusive List of Sensor Systems (Current, In Development, and In Concept)**

The Search and Detection goals were: (1) 100% coverage within 24 hours of assets on station, with an 80% RMP for the coverage factor (confidence) MOP; and (2) a Pd of 0.8 (80%). The RMP aspect of Search and Detection can be achieved by using the same sensors as described for the environmental assessment and listed in Table 13. Additional assets include the ERS (for satellite imagery and detection of surface and subsurface vessels) and air and surface assets within the AOR that can image the ocean area (from the surface to 50 meters deep) in order to provide timely feedback to operational commanders.

The purpose of the RMP is to provide the operational commander with a broad overview of the contact picture (mainly white shipping present in the AOR), which does not necessarily include enemy submarines and UUVs. The detection of enemy

submarines and UUVs is under the Pd goal. The problem addressed in this thesis assumed that white shipping was present only until hostilities begin. After hostilities started, white shipping was lowered by 90%.

3.4.3.2.1 DETECTION MODELING. The goal of detecting enemy submarines and UUVs in the OA was set at 80%. This was an overall goal, representing what an operational commander should expect once operations begin. However, stating simply that an 80% Pd is needed may not be enough, because it doesn't specify how long it will take the sensors to reach that 80% goal. If 80% means detecting at a minimum eight out of 10 submarines or UUVs present in the OA, the follow-on statement needs to be made that states in how many hours or by when. Some of the analysis that follows addresses this time issue.

The goal of a Pd of 80% presents a unique challenge, because the Pd achievable by analyzing acoustics is only 50% through the use of the sonar equation. A greater than 50% Pd can be achieved through a combination of diverse platform types and diverse sensing platforms.

A sensor combination (acoustic and nonacoustic) to assist with detection can provide the operational commander with an improved probability of detection. The following method is an example of the outcome of using diverse sensing devices and platforms, in addition to various means of detection:

$$\begin{aligned} \text{With the following probabilities: } \quad P_{d_{\text{acoustics}}} &= 0.50 \\ P_{d_{\text{satellite}}} &= 0.60 \end{aligned}$$

Calculating the total Pd entails first calculating the probability of not detecting the enemy submarine or UUV:

$$\begin{aligned} P(\text{not } d)_{\text{total}} &= (1 - P_{d_{\text{acoustics}}}) * (1 - P_{d_{\text{satellite}}}) \\ &= (1 - 0.50) * (1 - 0.60) \\ &= (0.50) * (0.40) \\ &= 0.20 \end{aligned}$$

In essence, then, the probability of detection is simply 1 minus the probability of not detecting enemy submarines or UUVs.

$$\begin{aligned} Pd &= 1 - P(\text{not } d)_{\text{total}} \\ &= 1 - 0.20 \end{aligned}$$

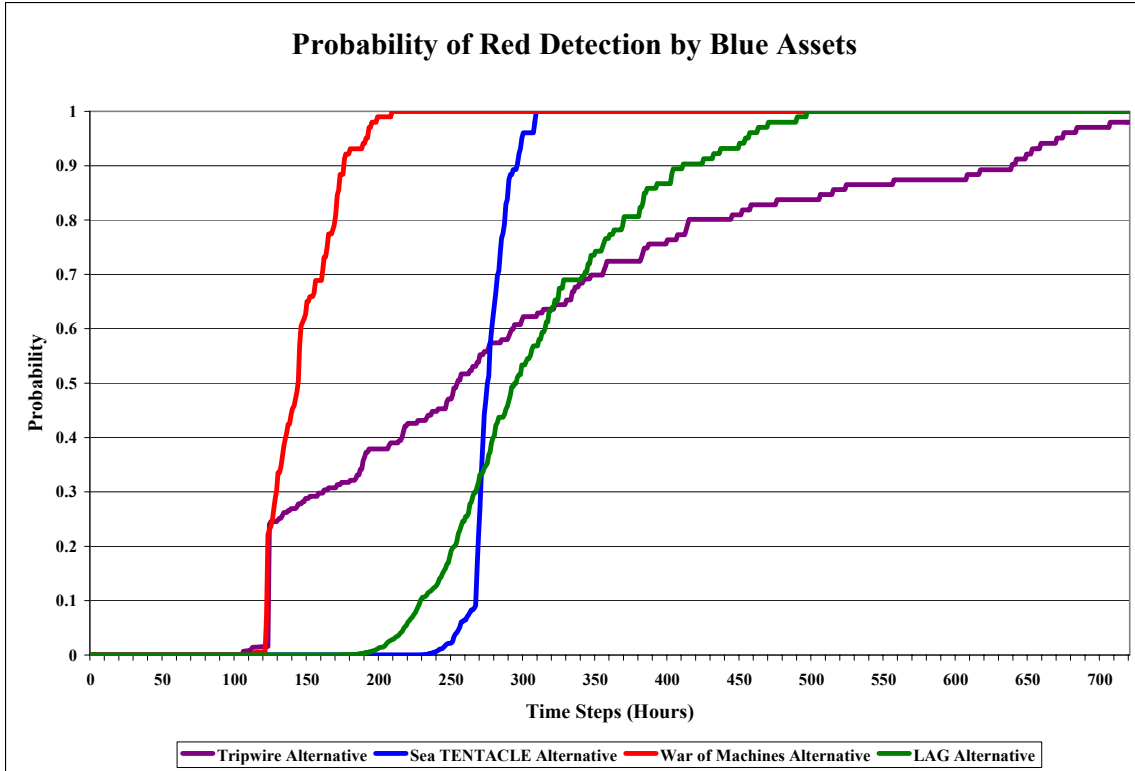
$$= 0.80$$

The resultant probability of detection was determined to be 0.80, which, in this case, met the goal set forth in the Objectives Hierarchy and, in a simplistic manner, answered the question of how that specific goal can be achieved.

More complex modeling tools provide an idea, based on a specific sensor set, of the time it takes to achieve the probability of detection required. The specific sensor sets were incorporated into each of the four alternatives generated. Two modeling tools were used to generate probabilities of detection of Red assets. The first is PC IMAT, which provided ranges based on environmental data and specific time of year sound velocity profiles. The PC IMAT inputs were used to build the overall models in NSS, and are detailed in Section 3.4.4.1.7. The NSS modeling aspects can be found in Section 3.4.4.2.

NSS modeling outputs were imported into an Excel spreadsheet for analysis and graphed to provide a quick glance at the overall results. Three key issues were analyzed by exploring the data extracted from the NSS simulations. First was the Pd of all Red submarines by Blue assets per time step. This provided a view of how long it would take the assets in that scenario to reach a Pd of 80%. The second data point extracted looked at the Pd of any Red submarine by Blue assets per time step. In this instance, each scenario's data showed at what time step Blue assets reached the Pd goal for any Red submarine. The third and final point of analysis was taking a look at an instantaneous Pd of Red submarines by Blue assets per time step. This data was more comprehensive and utilized all 100 simulation runs in each of the scenarios as opposed to just looking at first detections. All three of the data points analyzed are shown in their respective graphs in Figures 99 through 101.

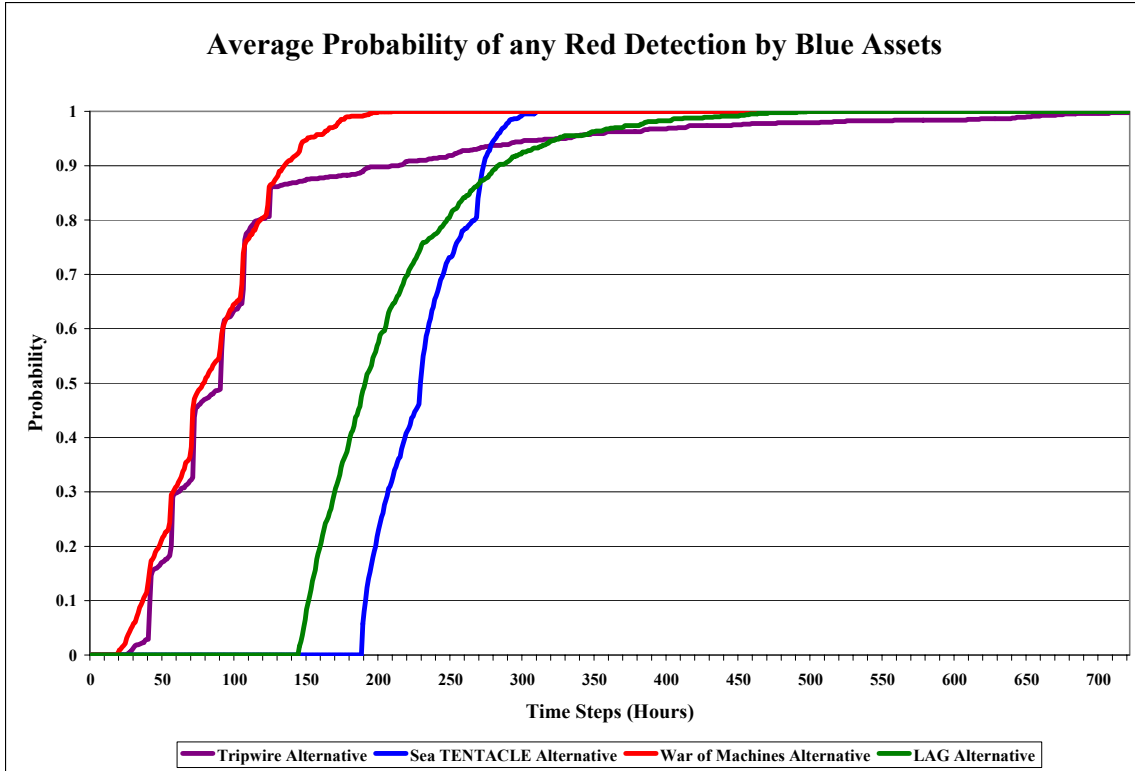
The Pd of all eight enemy submarines by each specific scenario hour is shown in Figure 99. The War of Machines alternative provided the best performance, with a Pd of 0.80 by 7 days 1 hour. This means that by 7 days 1 hour, the War of Machines alternative had achieved an 80% probability of detecting all eight Red submarines.



**Figure 99: Pd of All Red Submarines by Blue Assets per Time Step for Each Alternative**

Following the War of Machines alternative was the TSSE alternative, achieving a Pd of 0.80 in 12 days. Third in performance was the LAG alternative at 15 days 11 hours, and finally, the Tripwire alternative at 17 days, 8 hours. It is also important to note that the Tripwire alternative never reached 100% probability of detecting all eight Red submarines in the 30-day scenario.

Figure 100 shows the probability of detecting any one of the eight enemy submarines by the scenario hour listed on the x-axis.



**Figure 100: Pd of Any Red Submarines by Blue Assets per Time Step for Each Alternative**

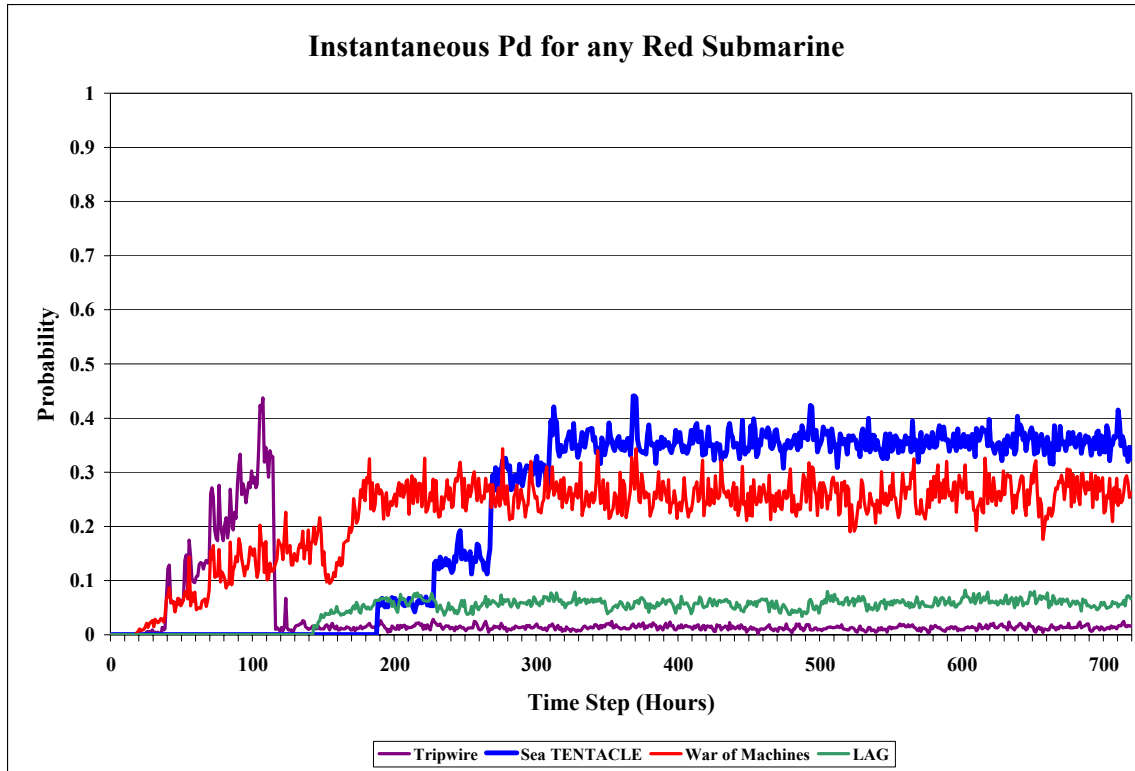
Individual alternative Pd of 0.80 for any Red submarine versus Pd of 0.80 for all eight Red submarines is summarized in Table 14.

Alternative	Pd=0.80 for ANY one of 8 Red Subs	Pd=0.80 for ALL 8 Red Subs
Tripwire	4 days 20 hours	17 days 8 hours
Sea TENTACLE	11 days 2 hours	12 days 0 hours
War of Machines	4 days 21 hours	7 days 1 hour
LAG	10 days 7 hours	15 days 11 hours

**Table 14: Comparison Chart of Pd=0.80 for Any and All Red Submarines Detected by Blue Assets**

Of interest was Alternative 2 (TSSE), which detected the first Red asset at 11 days 2 hours, and, within the next 22 hours, was able to detect the remaining seven Red submarines.

Figure 101 represents the likelihood of detecting a submarine at any time. All four alternatives are shown in order to compare the probabilities of detection during the initial phases of the scenario and the steady state Pd achieved after the sensors are in place and operating continuously.



**Figure 101: Instantaneous Pd for any Red Submarine by Blue Assets per Time Step Showing Initial Pd as Assets Enter Theater and the Steady State Pd with Permanence of Assets in Theater**

The Tripwire Alternative shows a steadily increasing Pd from hour 0 to hour 116 and then drops off to near 0. The increased Pd was as a result of Red submarines leaving port at specified intervals and passing through a Seaweb-based sensor (SWBS) (grid established at the entrance to these ports). The SWBS system, in conjunction with 15 UUVs, achieved a maximum Pd of 0.4375 at hour 107. By hour 116, the steady state Pd drops down to 0.013. This is due to the 80 hour battery life limitation of the UUVs. The value of Pd does not drop completely to 0 because the sea-web based sensors are still capable of detecting Red assets, but they are not strong enough to be considered militarily significant.

In the TSSE alternative, platforms began arriving in theater at hour 187 with a gradual buildup of sensors throughout the AOR, thus populating the AOR with sensors over time. This led to the stair-stepping Pd witnessed in Figure 101. A steady state Pd was finally achieved at hour 309 once all of the sensors were in place and operational. In this alternative, the maximum Pd was 0.4375 with a steady state Pd of 0.3569 (27 times improvement over Tripwire Alternative).

The War of Machines Alternative consisted of UUVs deployed over time, with recharging stations to ensure that operations remain continuous throughout the scenario. This alternative also demonstrated a gradual increase in Pd that began at scenario hour 0, and continued until all sensors have been deployed, including the recharging stations. The Pd achieves a high of 0.2263 at hour 123, but drops to 0.1025 at hour 156 (see curve in Figure 101 dip down) due to the UUVs starting to recharge, during which time they are nonoperational. The steady state Pd was achieved at 0.26, and the maximum Pd for this alternative reaches 0.3263, slightly lower than the TSSE Alternative.

The final alternative, LAG, was based on the conventional approach to ASW. This alternative was slow to start because of the time required for assets to arrive on station. In this alternative, assets arrived on station and began detecting Red submarines by hour 142 (5 days 22 hours). The Pd gradually increased until a steady state Pd of 0.057 was reached throughout the scenario.

Data represented in Figure 101 is different than the Pd represented in Figure 100. Figure 100 represents a cumulative Pd over each time step and was based on first or initial detections of each iteration of the scenario (100 total iterations), whereas Figure 101 data represents each alternative's instantaneous ability to detect a submarine at that given time step and was based on the average number of detections for each time step over all iterations in the scenario. In other words, as Blue assets enter the theater of operations, the Pd was determined not only by their sensor range, but also by their permanence in the AOR.

Table 15 summarizes the maximum Pd shown in Figure 101 and explained in the paragraphs following the graph:

Alternative	Pd Start Hour	Maximum Pd	Steady State Pd
Tripwire	107	0.4375	0.0130
Sea TENTACLE	187	0.4375	0.3569
War of Machines	17	0.3263	0.2600
LAG	142	0.0800	0.0570

**Table 15: Summary of Pd for each Alternative with the Start Hour, Maximum Pd, and Steady State Pd**



If considering Pd as a key metric in determining best alternative, the TSSE and War of Machines alternatives provide the best Pd among all four alternatives, as shown in Table 15.

Table 16 is a spreadsheet of “best combinations” that can be used to generate a higher Pd. This spreadsheet was created by using the same sensor combination simplistic model as used previously in this section where the P(not d) of each of the alternatives being combined were multiplied together in order to arrive at a P(not d)<sub>total</sub>, and then subtracting this value from 1 to get a Pd of the combination of methods. The data shows that if the maximum achieved Pd was utilized, the best choice is a combination of Alternatives 1 and 2 or a combination of all three alternatives together, with alternatives 1, 2, and 3 or alternatives 1, 2, and 4 combined to give a Pd greater than 0.70.

<b>Pd Achieved by Combining Alternatives</b>		
<b>Alternative</b>	<b>Max Pd</b>	<b>SS Pd</b>
Tripwire and TSSE	0.6836	0.3653
Tripwire and War of Machines	0.6210	0.2696
Tripwire and LAG	0.4825	0.0693
Sea TENTACLE and War of Machines	0.6210	0.5241
Sea TENTACLE and LAG	0.4825	0.3936
War of Machines and LAG	0.3802	0.3022
Tripwire, Sea TENTACLE and War of Machines	0.7868	0.5303
Tripwire, Sea TENTACLE and LAG	0.7089	0.4014
Tripwire, War of Machines, and LAG	0.6514	0.3113
Sea TENTACLE, War of Machines, and LAG	0.6514	0.5512
Tripwire, Sea TENTACLE, War of Machines, and LAG	0.8039	0.5571

**Table 16: Pd of Combined Alternatives using Max Pd and Steady State Pd to Determine the Ideal Combination of Alternatives that Provides a Higher Pd**

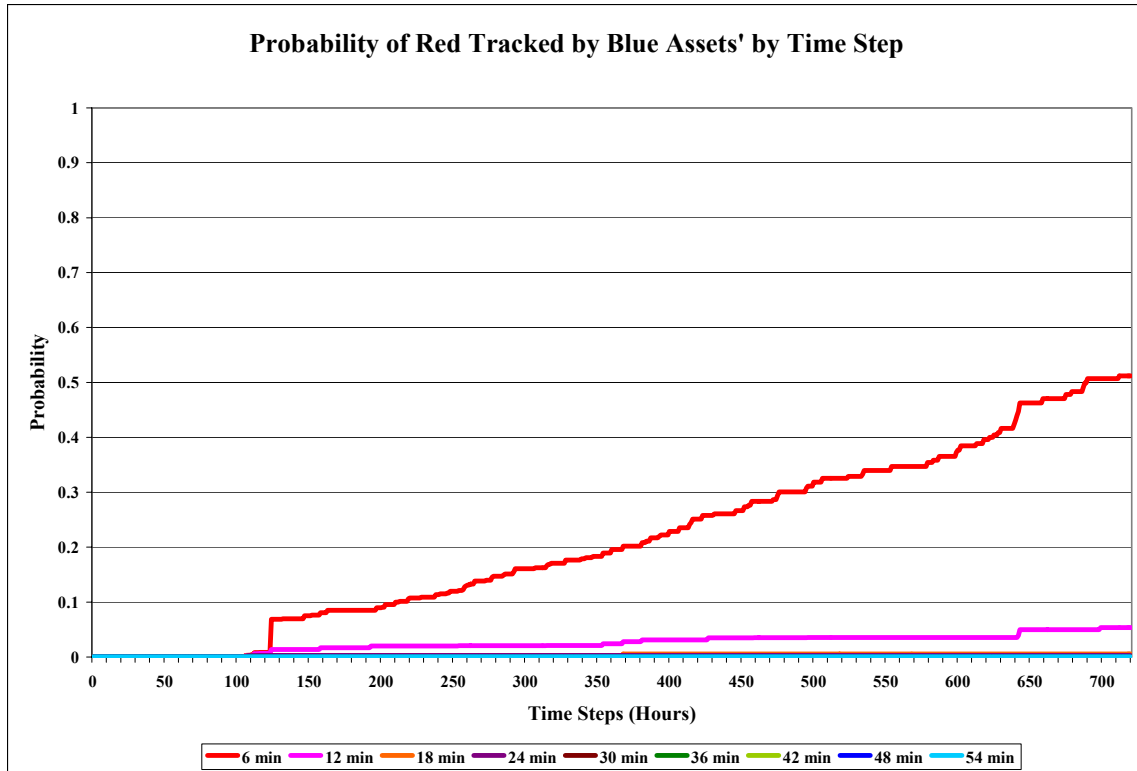
Utilizing a combination of all four alternatives, the instantaneous Pd was to meet the assigned goal of 0.80. However, the steady state (SS) Pd produced lower expected Pd values. The combination of alternatives that provided those higher probabilities shows a Pd slightly above 0.50. Using this as a low-end, the conclusion was that a combination of alternatives provided a Pd between 0.50 and 0.80. However, an instantaneous probability of 0.06 (obtained by combining steady state or instantaneous Pd for Tripwire and LAG) may be enough to provide a Pd of 0.80 over a specific amount of time steps, a metric not defined within this goal. Individual graphs with supporting data are shown in Appendix C for Figures 99 through 101.

### ***3.4.3.3 Tracking***

The data used to analyze each alternative's ability to track was extracted from NSS and evaluated, from which SEA-8 could then draw its conclusions. The metric analyzed was the probability that a Blue asset could track a Red submarine long enough to contribute to one or more of the following actions:

- handoff the information to a weapon platform;
- generate a fire control solution;
- classify the Red submarine;
- launch a weapon;
- force the Red submarine to leave the OA; and
- defeat Red submarine

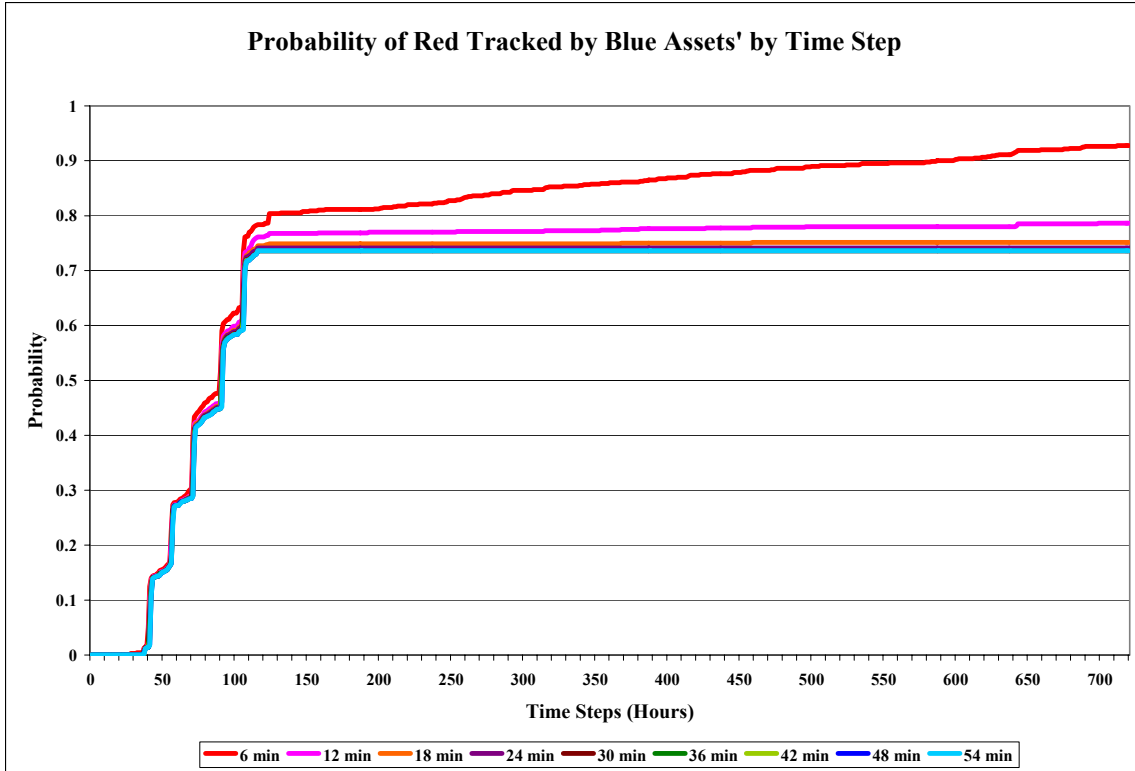
The amount of time required for tracking, therefore, was dependent on the operational requirements. This time could potentially range from a few seconds to hours or even days. This research investigated the metric of evaluating the probability that a Blue asset can track a Red submarine in 6-minute intervals from 6 minutes to 54 minutes. In the case of tracking, this was simply a confidence level of how probable it was that the assets involved in each alternative will track for the amount of time needed. Tripwire was the first alternative examined and is represented in Figure 102:



**Figure 102: Probability that Blue Assets can Successfully Track Red Submarines per Time Step in 6-Minute Intervals for Alternative 1 – Tripwire**

This scenario does not provide a good overview of Blue’s tracking ability, it shows a very low confidence level. Figure 102 represents the Tripwire Alternative’s sensors’ ability to track all eight Red submarines. Sensors in the Tripwire alternative were designed to detect a Red submarine when it leaves port. After a Red submarine leaves port, the alternative depends on sea-web based sensors and a limited number of UUVs to continue tracking Red submarines. The results shown in Figure 102 indicate this alternative lacks the ability to track with the Sea-web sensors and the UUVs, which have tracking capabilities, have only an 80-hour endurance. If the expected confidence level for this alternative was to provide the operational commander with a 90% confidence level that the sensors will have the ability to track all Red submarines for any period of time, this alternative has clearly failed.

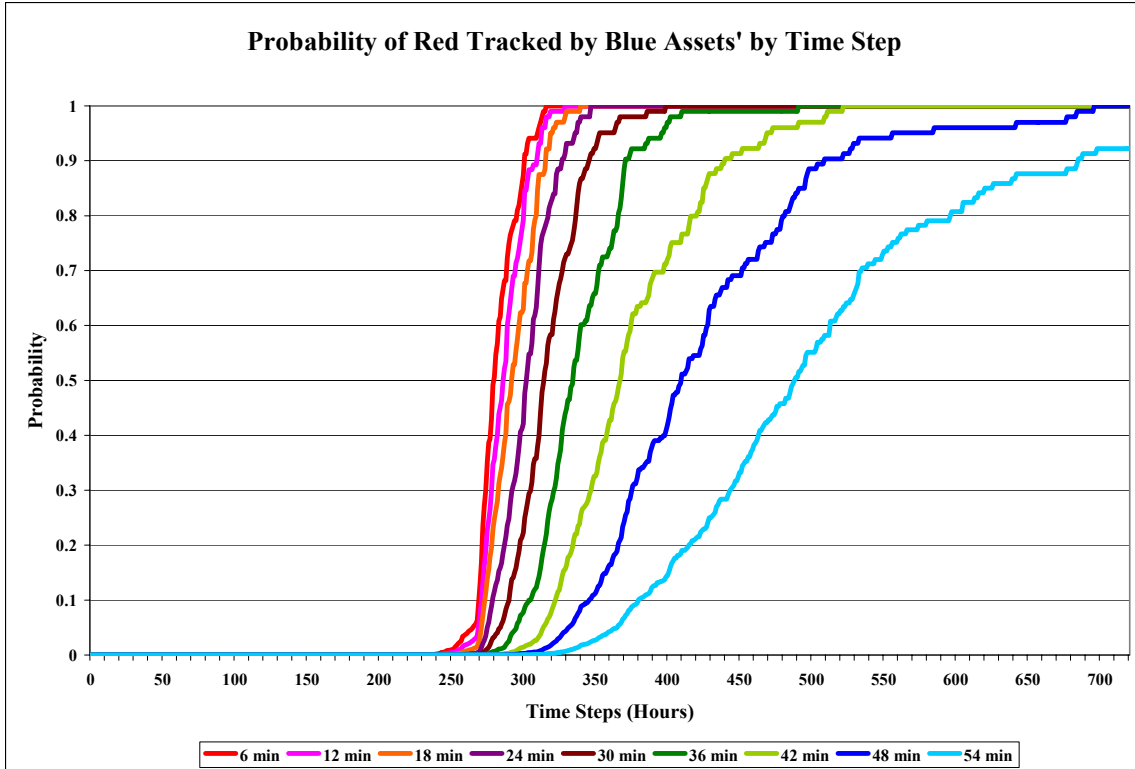
Figure 103, however, represents Tripwire’s ability to track any one of Red’s eight submarines for each designated period of time.



**Figure 103: Probability that Blue Assets can Successfully Track Any One Red Submarine per Time Step in 6-Minute Intervals for Alternative 1 – Tripwire**

While this data looks more promising than that which is shown in Figure 102, a 90% confidence level was only achieved in the six minute tracking time and only after 598 time steps (24 days 22 hours).

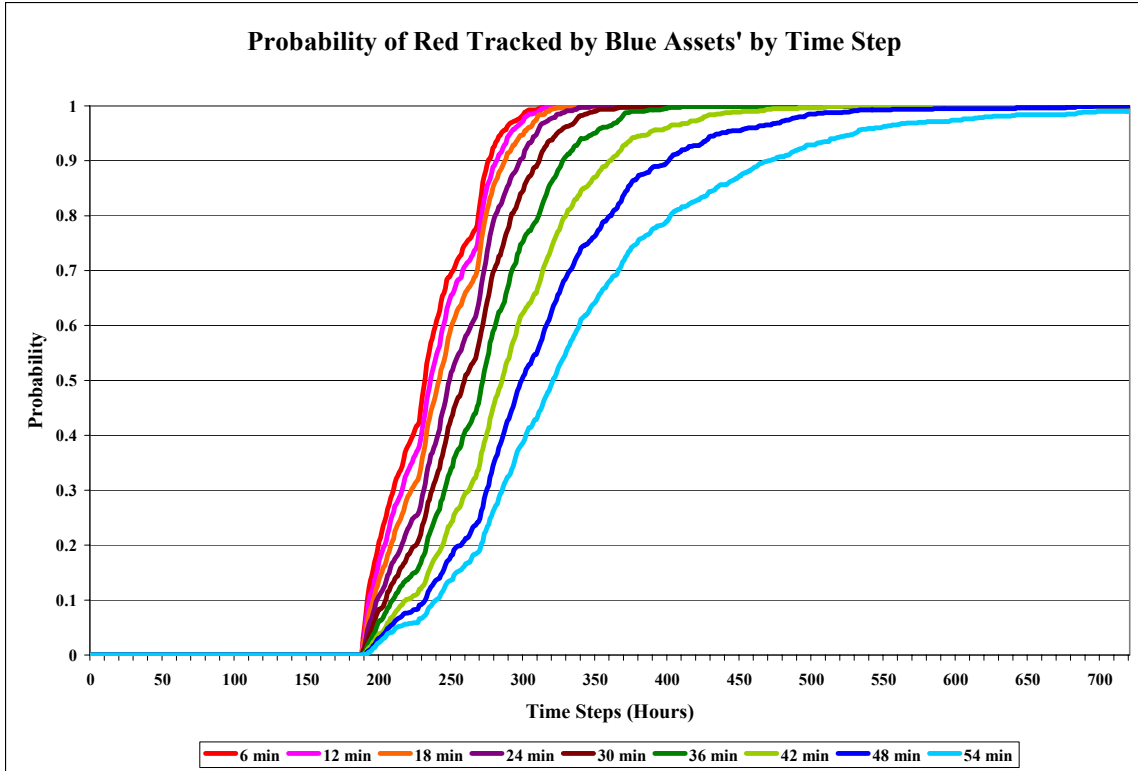
The second alternative examined was TSSE. This scenario shows a significant improvement in the tracking ability over the Tripwire alternative. Figure 104 shows the probability that the sensors in the TSSE alternative can track all eight Red submarines. After time step 240, the 6-minute tracking ability shows an almost vertical probability of tracking capability, with the slope of subsequent time intervals gradually decreasing. As Figure 104 shows, 100% confidence in Blue asset’s tracking capability was eventually achieved by all of the time requirements, with the exception of the 54-minute tracking requirement.



**Figure 104: Probability that Blue Assets can Successfully Track Red Submarines per Time Step in 6-Minute Intervals for Alternative 2 – TSSE**

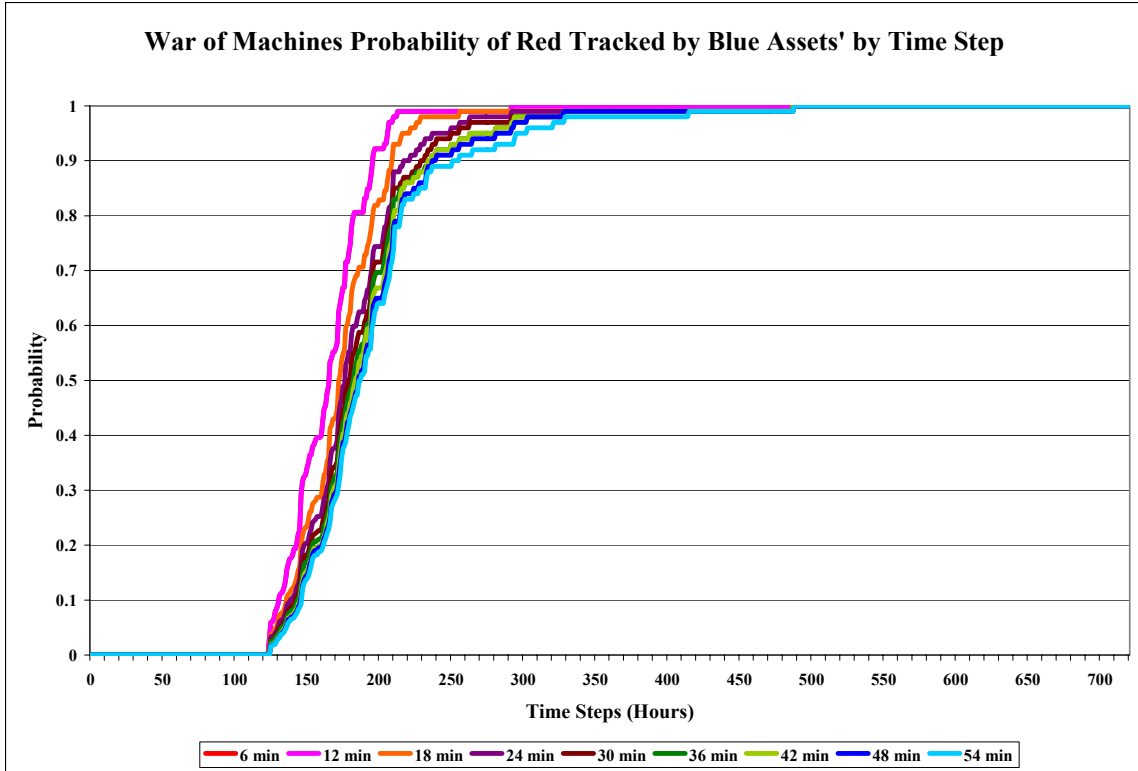
While this alternative does not fail in the same sense that the Tripwire alternative fails to provide a high tracking confidence level, the fact that it takes almost 250 time steps to achieve tracking may have a negative impact on operational commitments.

Figure 105 shows the probability that Blue assets can successfully track any one Red submarine per time step for each of the 6-minute intervals. Unlike the results shown in Figure 104, when just one Red submarine was tracked, the sensors in this alternative start showing the ability to track at time step 190. By time step 250, the 6-minute tracking requirement shows a 70% probability, which may be a high enough confidence for an operational commander.

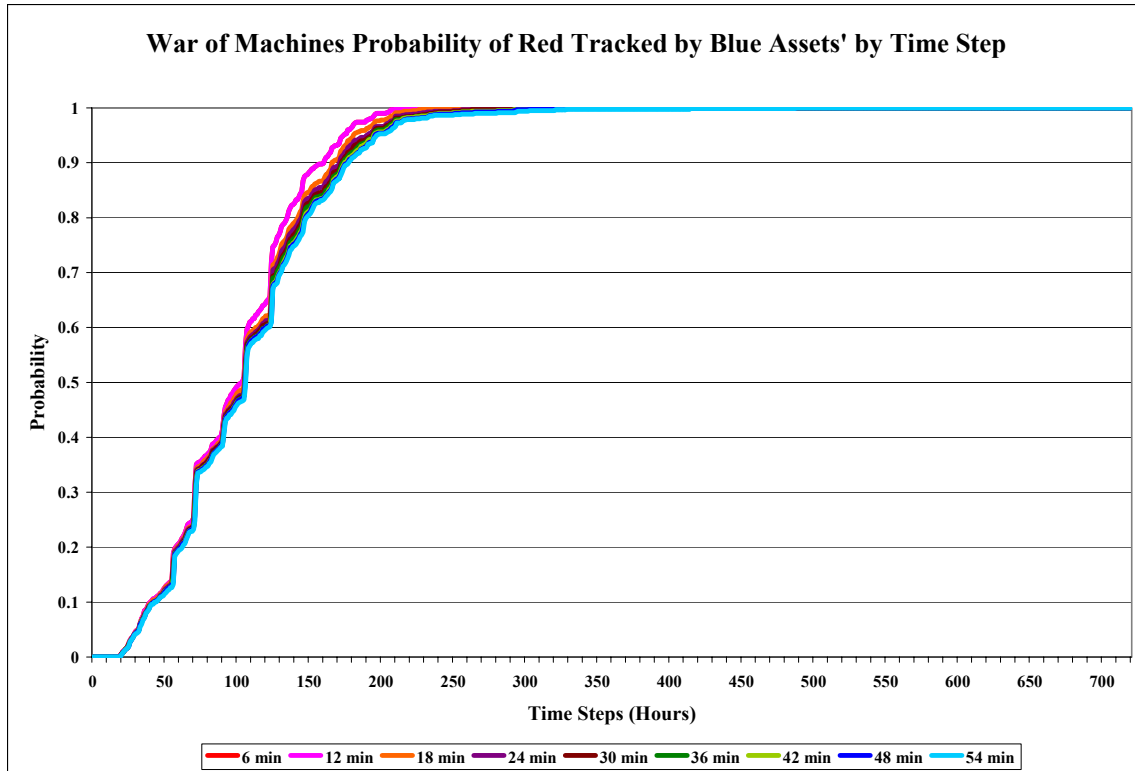


**Figure 105: Probability that Blue Assets can Successfully Track Any One Red Submarine per Time Step in 6-Minute Intervals for Alternative 2 – TSSE**

The third alternative was War of Machines. This alternative produced results that show a significant improvement in Blue’s ability to successfully track any (Figure 106) or all (Figure 107) Red submarines over each of the previous two alternatives. In Figure 106, the ability of Blue assets to track Red submarines over the required time period was almost identical for each of the nine time intervals evaluated. A confidence level greater than 90% was achieved within 100 time steps of the first indications that Blue can track all of Red continuously for each time interval studied.



**Figure 106: Probability that Blue Assets can Successfully Track Red Submarines per Time Step in 6-Minute Intervals for Alternative 3 – War of Machines**



**Figure 107: Probability that Blue Assets can Successfully Track Any One Red Submarines per Time Step in 6-Minute Intervals for Alternative 3 – War of Machines**

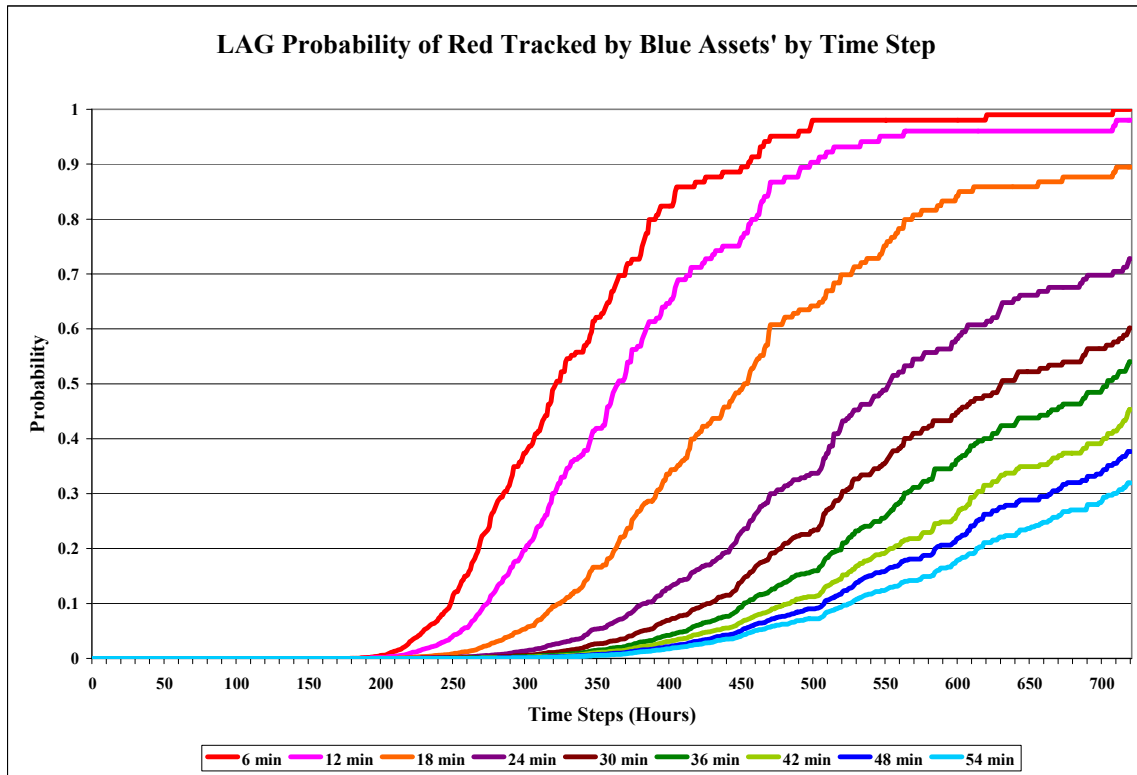
While the TSSE alternative showed that the tracking probability starts to increase at time step 250, this alternative demonstrated that, by time step 250, all of the evaluated time intervals reach a 100% confidence level in Blue’s tracking ability.

Figure 107 shows that Blue assets have a constantly increasing ability to track any one Red submarine. In addition, the probabilities of Blue successfully tracking Red for each time interval studied are almost identical. By time step 160, the confidence level reaches 90% on all nine time intervals. At a quick glance, the conclusion could be made that if the time to achieve the required confidence level was in line with the time steps represented by this scenario, this alternative succeeds in providing that required tracking capability.

The LAG alternative tracking capability confidence levels are represented in Figures 108 and 109. Figure 108 shows Blue assets’ ability to track all of Red’s submarines over the time steps and in the tracking time intervals needed for the kill chain to take place. This alternative was probably the second weakest alternative in that it never reaches a 100% confidence in Blue’s tracking ability for all eight enemy submarines. The

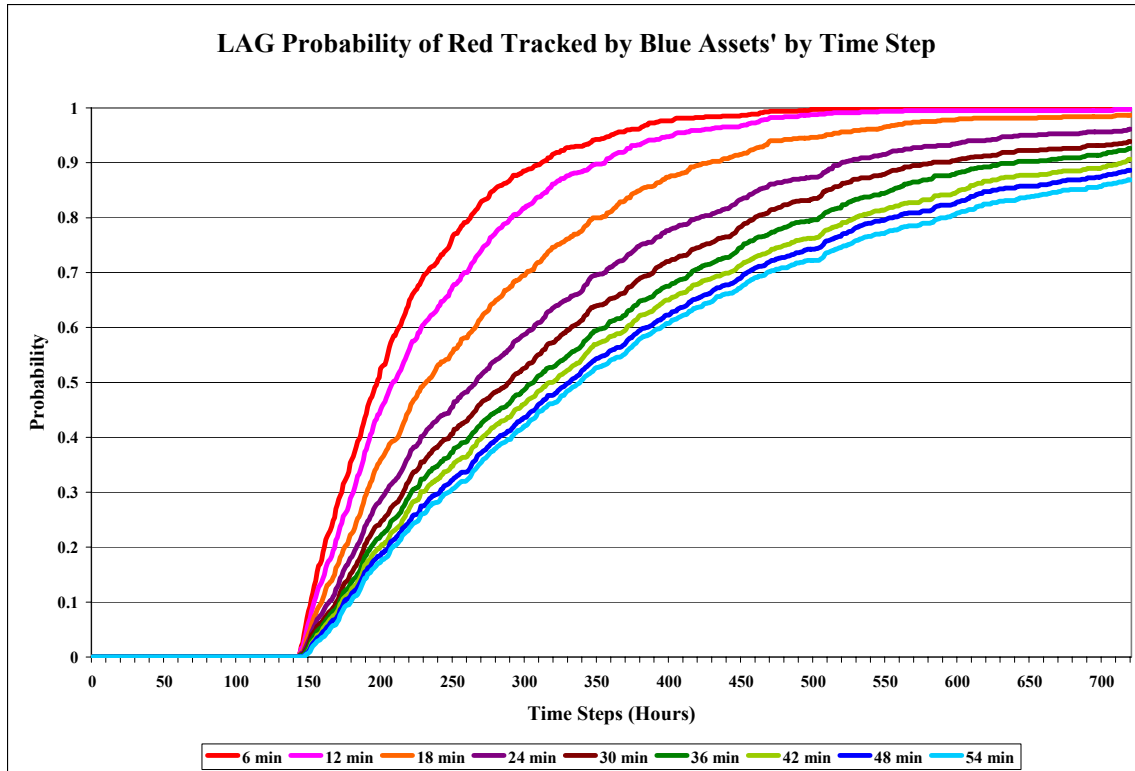


increase in confidence level was gradual and takes dozens of time steps for small improvements in performance.



**Figure 108: Probability that Blue Assets can Successfully Track Red Submarines per Time Step in 6-Minute Intervals for Alternative 4 – LAG**

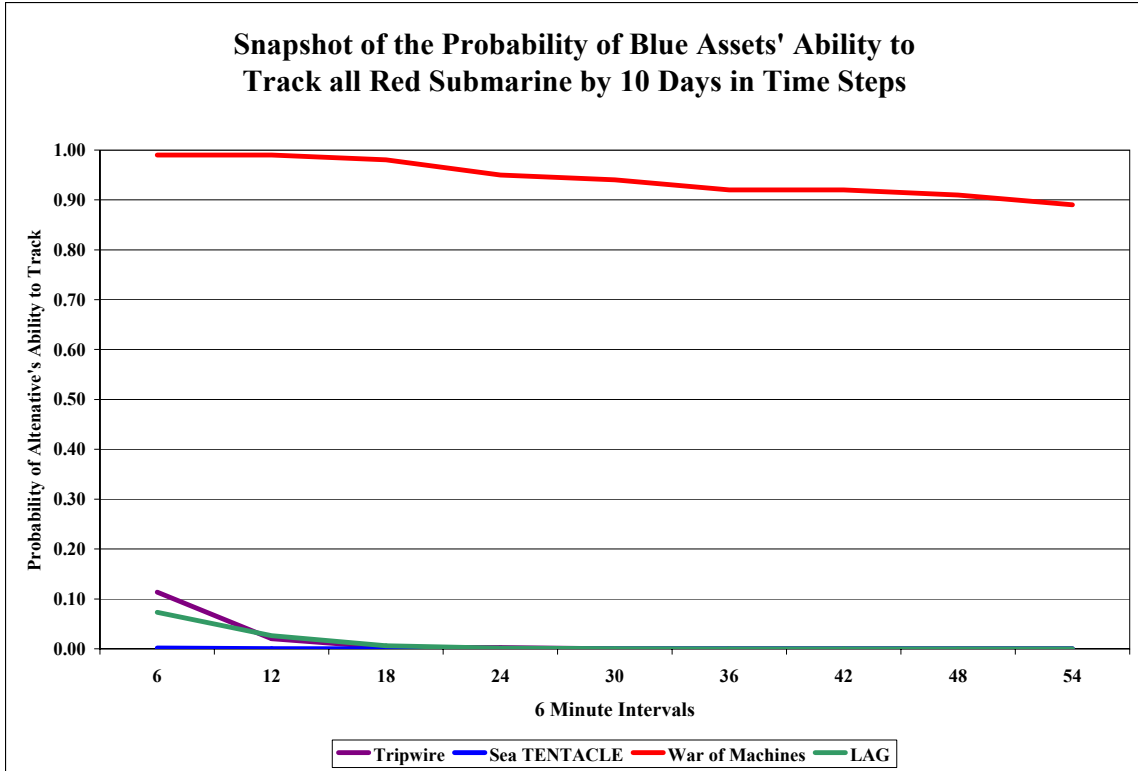
Figure 109 shows the probability that Blue can track any one of Red’s submarines at each of the time intervals. As the graph shows, the increase in probability was sharp at first, but as time progresses, the confidence levels take longer time to reach, with only the 6-minute tracking time reaching 100% in the scenario.



**Figure 109: Probability that Blue Assets can Successfully Track Any One Red Submarine per Time Step in 6-Minute Intervals for Alternative 4 – LAG**

General conclusions can be drawn from all of the data analyzed above. The best way to evaluate which alternative succeeds over other alternatives was to take a look at which alternative impacts the kill chain more than the others.

By taking a snapshot of a specific time step, and by putting all of those data points on the same graph, one can see which alternative provided the strongest and weakest link in the kill chain. Figure 110 shows that specific snapshot at time step 240 (10 days into the scenario) for Blue’s ability to track all eight Red submarines for the time intervals that were evaluated in the graphs above. As the graph clearly shows, the War of Machines alternative has the ability to track all eight Red submarines for any of the nine time intervals evaluated. Although the confidence level slowly decreases, the change does not exceed 10%. In the other three alternatives, the tracking confidence level remains slightly below 10% and quickly drops to 0 as the time interval increases.



**Figure 110: Snapshot of the Probability of Blue Assets Being Able to Track All Red Submarines by 240 Time Steps**

Figure 111 shows Blue’s ability to track any of Red’s eight submarines. The War of Machines alternative shows an unhindered ability to track in either of the nine time intervals with a slight, but insignificant, decrease in the confidence level. The second best alternative is Tripwire, which plateaus at 75% confidence by the 24-minute time interval. LAG and TSSE alternatives both show a gradually decreasing ability to continuously track a Red submarine at greater time intervals. The lowest confidence is 10% at the 54-minute interval for TSSE and 25% confidence at the same time interval for the LAG alternative.

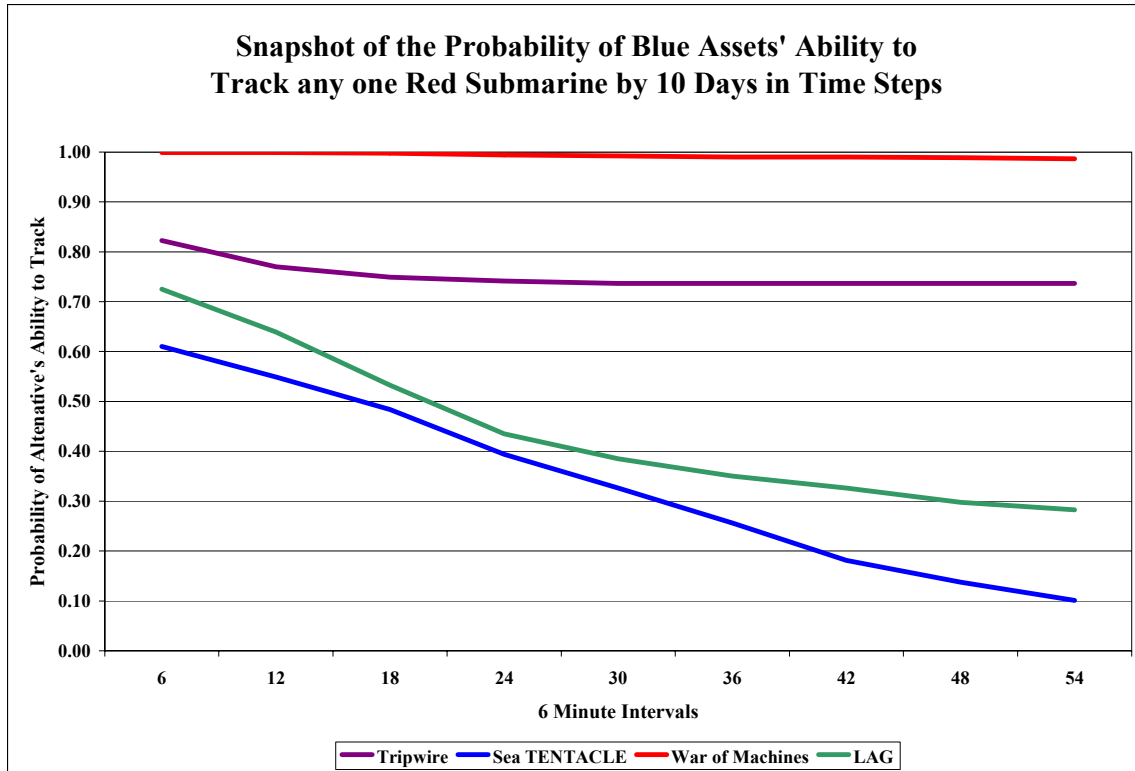


Figure 111: Snapshot of the Probability of Blue Assets Being Able to Track Any One of Red's 8 Submarines by 240 Time Steps

### 3.4.4 High Level Modeling: NSS

#### 3.4.4.1 Introduction to Modeling With NSS

A model is a simplified representation, developing a description of a system that accounts for all of the system's important properties. For purposes of SEA-8, we consider the definition of a model to be a set of mathematical relationships and logical assumptions implemented into a computer as a representation of some real-world decision problem.<sup>182</sup> For us, this real world decision problem was Littoral ASW in 2025.

The modeling phase of the SEDP required that we use modeling and simulation as a means of comparing the predicted performance of our four distinct design alternatives with respect to the evaluation measures we selected in our

<sup>182</sup> Cliff T. Ragsdale, (2001), *Spreadsheet Modeling and Decision Analysis*, South-Western College Publishing, Ohio.

Value Hierarchy.<sup>183</sup> These evaluation measures were used to predict and estimate a specific alternative's overall performance.

In order to gain the necessary insight and to fully analyze the interaction of the dynamic variables presented by the challenge of littoral ASW, SEA-8 utilized NSS. This modeling program was used specifically to consider interactions between platforms within our scenario. Command, control, and logistics were inputs to the model, but were not effectively modeled by our use of NSS. Instead, the metrics and interactions of prosecution were the focus of NSS modeling efforts. Therefore, the efforts of this team (the Modeling Team) are considered Prosecution Team modeling.

NSS is an object-oriented Monte Carlo modeling and simulation tool that has been developed, validated, and verified by Space and Naval Warfare Command (SPAWAR) PD-15. The main goal of this model is to facilitate the analysis of four alternatives by comparing their performance within the given scenario.

3.4.4.1.1 NSS. NSS is a powerful, object-oriented, modeling and simulation tool. It has been employed in numerous Navy-led exercises and studies and has proved itself to be a valuable warfare assessment tool. It is utilized by the analysis community in support of high-level concept assessments and system effectiveness studies.<sup>184</sup>

The vision of NSS is that of a set of validated low-to-medium resolution warfare entity models, certified data, appropriate simulation services, and related user support tools in a framework suitable for modeling multi-warfare scenarios.<sup>185</sup>

The modeling team for Prosecution found NSS is less focused on a prediction of an absolute outcome like traditional discrete models and more focused on promoting creativity through the visualization of the battlespace, which allowed us to assess a range of likely plans, tactics, and outcomes, and in doing so, effectively evaluate the strengths and weaknesses of various alternatives.

Representations of SEA-8's proposed alternatives were constructed and tested in a simulated environment with no "man-in-the-loop." All commander,

---

<sup>183</sup> Professor Gene Paulo, (2005), Systems Engineering and Architecture handout, Naval Postgraduate School, Monterey, CA, February 2005.

<sup>184</sup> METRON Incorporated, Naval Simulation System Analyst Guide, 31 August 2002, p. 6.

<sup>185</sup> Ibid., p. 6.

platform, and system entities were fully simulated. Analysis of these alternatives allowed for a detailed understanding of the capabilities, performance, and interaction among forces within our scenario. The result was a better understanding of system interactions and quantitative assessment of forces with their associated ASW systems.

#### 3.4.4.1.2 MONTE CARLO STATISTICAL CONCEPTS.

Typical Monte Carlo metrics are random variables that are computed once for each Monte Carlo replication of each scenario. An example of a random variable would be the placement of underway enemy submarines at the start of each replication.

#### 3.4.4.1.3 NSS REPRESENTATIONS.

All NSS platforms used in the scenario had specific attributes identifying alliance, asset type, and operating medium (air, surface, or subsurface). Specifically, all individual platforms are given unique motions or maneuvering orders, a unique susceptibility to detection, platform specific sensors and system attributes, and a unique command structure.

**PLATFORM MOTION:** All NSS platform-level objects have an initial motion plan that is valid for the duration of the scenario (one full replication). This motion plan is subject to change during the simulation, based on the simulated actions of the platform, mission area, or on orders of the assigned warfare commander. Ships and submarines are assigned to be stationary, have a track/formation motion, conduct an area/barrier patrol, or complete a complex motion, which is a combination of these. Additionally, a transit speed, search speed, and tactical response speed is assigned to each platform. The Modeling Team utilized all such motions within the scenario and given alternatives.

Track motion for surface and subsurface assets is conducted by assigning a track of specified waypoints to a specific platform. The platform will start the track on assignment and will maintain that track unless specified to do otherwise.

Area patrol motion for surface and subsurface assets is conducted by assigning a region defined by user imputed data points that are connected to form the region. The platform can start at a specified or random point with the region and/or track to the region before commencing the patrol. Distributions for the time between successive course changes, leg speed, and loiter times at the end of each patrol leg are

specified or random depending on the scenario. For example, Red AIP submarine patrols were highly randomized, while Blue submarines had a more specified patrol motion.

Barrier patrol motion for surface and subsurface assets starts at the beginning of the replication or when specified by the user. The platform transits back and forth unless vectored elsewhere. For example, a Blue submarine may perform a barrier patrol until a Red asset is detected. The Blue submarine will then commence tracking the enemy platform. If the track is lost, then the friendly asset will return and again commence a barrier search.

Complex motion was the most widely used by the Modeling Team. This motion allows for the combination of various other motions. It employs a series of user defined track, area patrol, and/or barrier patrol motion plans for an individual platform. The platform will operate as assigned unless vectored elsewhere to track a detected enemy platform, for example. If track is lost then the platform will resume the motion it was originally assigned.

**SUSCEPTIBILITY TO DETECTION:** In NSS, the ability of a platform to be detected is modeled through the use of conceptual “detectable signature” objects that are associated with each NSS platform. A detectable signature is specified in terms of its type, the platform properties that can be determined when it is detected, the sensor types that can detect it, and its schedule.<sup>186</sup> For example, the Red AIP submarine is a subsurface asset with both active and passive sonar as well as radar that is activated according to a periscope schedule that is user selected. These acoustic and radar signatures indicate an enemy AIP submarine when detected by friendly assets.

**COMMANDERS:** All NSS force assets are supported by numerous subsystem managers and one or more commanders. Subsystem managers are internal software constructs that provide an interface between the force asset (i.e., submarine or UUV) and its associated subsystem (i.e., passive sonar suite). There are three different types of commanders: Group Commanders, which may be assigned to a specific asset to control a group of assets; Warfare Mission Area (WMA) Commanders, which may be assigned to a specific asset and periodically request control of a Group Commander’s assets in order to perform a plan or tactic pertaining to a specific

---

<sup>186</sup> METRON Incorporated, Naval Simulation System Analyst Guide, 31 August 2002, p. 49.

mission area (This would allow the WMA Commander to vector assets to track or utilize platforms' sensors to their benefit. To alleviate competing demands for assets, a WMA prioritization scheme is employed to determine which allocations are executed.); and the Asset Commander, which simply interfaces with and controls all subsystem managers associated with a specific asset.<sup>187</sup>

**COMMUNICATIONS:** The Modeling Team chose “Assured Communications” for NSS modeling. Under assured communications, messages and communications plans are represented explicitly by link terminals, communications nodes, and networks. All planned communications succeed with a probability of 1.0 and without regard to communications coverage limits, network contention, or other complicating factors. However, transmission delays are input by the user to provide time for processing transmissions and reaching posture requirements for transmission.

Assured communications is hence generally applicable to operational situations or analysis in which communications connectivity and availability are not to be modeled in detail.<sup>188</sup> Assured communications was selected for two reasons: first, this provided simplification to the model and allowed the team to focus on the ability of our system alternatives to detect and track. Secondly, a detailed, communication-specific model was developed by the C4ISR Team to study this aspect of the system and reached a level of abstraction that surpassed the capabilities of NSS.

The way in which an Assured Communications Plan is used in an NSS simulation is as follows. Whenever a platform in either alliance (Red or Blue) determines the need to send a message, the following communications plan processing steps are triggered:<sup>189</sup>

- If the message is a C2 message, it is sent to all intended recipients with simulated delays as specified by the user.
- For contact and track reporting, the message is sent to all receivers associated with the send as specified in the connectivity plan, with a specified minimum and maximum transmit delay time declared by the user.

---

<sup>187</sup> Ibid., p. 61.

<sup>188</sup> METRON Incorporated, Naval Simulation System Analyst Guide, 31 August 2002, p. 79.

<sup>189</sup> Ibid.



3.4.4.1.4 ENVIRONMENTAL REPRESENTATION. NSS explicitly represents bathymetric contours and the impact of bathymetry on ocean surface or subsurface platform motion and system level of performance. However, NSS does not explicitly represent other aspects of the ocean environment such as water temperature, thermoclines, etc. To account for this limitation of NSS, the Modeling Team utilized PC IMAT version 3.0 to calculate accurate propagation data that could be accounted for in NSS by altering a specific sensor's ability to detect submarines at given ranges. A detailed explanation of how PC IMAT was used to generate NSS inputs can be found in Section 3.4.4.1.7.

3.4.4.1.5 METRICS. NSS provides a comprehensive set of predefined metrics in the categories of state variables versus time, averaged event values versus time, event counts versus time and event times. State variables versus time measures the instantaneous value of a specific state variable. An example would be the number of detections at a specific hour in the scenario.

Event counts versus time counts the number of occurrences of events of a specific type, such as detections, made for a given calculation time. Event times record the individual times of each occurrence of a specific type.

For each metric type, the Modeling Team was able to specify the calculation times associated with each metric or we could specify the condition under which the metric instance was to be computed. The latter was most beneficial. For example, we were able to record the sum of all tracking times for all Blue forces or a single platform against enemy forces.

3.4.4.1.6 TRACKING METRICS. The primary metrics utilized by the Modeling Team to fully analyze our four distinct alternatives are outlined below.

- **Surveillance Detections:** For the detectable asset (Red AIP submarines), this metric counts the number of detection events simulated to occur during the time interval in question. For tracking sensors, detection events include start/end track and track update events. For nontracking sensors, detection events are equivalent to sensor detection events.<sup>190</sup>

---

<sup>190</sup> Ibid., p. 366.

- **Tracking Sensor Events:** For the detectable asset, this metric counts the number of track events simulated to occur during the time interval in question.<sup>191</sup>
- **Tracking Sensor Status Change Time:** For the detectable asset, this metric records the times of initial detection, time(s) of track updates, and loss of track for each track held by the tracking sensor.<sup>192</sup>
- **Total Tracking Time:** For the detectable asset, this metric records the total time a given track is held by any tracking sensor in each time interval in question. For multiple tracks held simultaneously, the time recorded is the total length of time there is a track held by any of the selected tracking sensors. The maximum possible time that can be returned by this metric is the length of the interval.<sup>193</sup>

3.4.4.1.7 PC IMAT. PC IMAT was used to determine approximate detection ranges of enemy submarine assets by various Blue forces. The four inputs resulting in propagation loss curves for the Bass Strait: 1) enemy operating depth was assumed to be 100 feet (30 meters); 2) the frequency of concern was determined to be 50 Hz; 3) the common bottom type of the Bass Strait is sand;<sup>194</sup> and 4) the most common wind speed in the Bass Strait is between 10 knots and 20 knots.<sup>195</sup> These inputs resulted in the following winter and summer propagation loss curves, shown in Figures 112 and 113.

---

<sup>191</sup> Ibid.

<sup>192</sup> Ibid.

<sup>193</sup> Ibid.

<sup>194</sup> Australian Fisheries Management Authority, “Bass Strait Central Zone Scallop Fishery, Data Summary 2003,” p. 14.

[http://www.afma.gov.au/information/publications/fishery/data\\_summ/docs/bass\\_2003.pdf](http://www.afma.gov.au/information/publications/fishery/data_summ/docs/bass_2003.pdf).

<sup>195</sup> Australian Bureau of Meteorology, “Wind Speed and Direction Rose” for East Sale, LAT 38.11S LON 147.13E, [http://www.bom.gov.au/cgi-bin/climate/cgi\\_bin\\_scripts/windrose\\_selector.cgi](http://www.bom.gov.au/cgi-bin/climate/cgi_bin_scripts/windrose_selector.cgi).

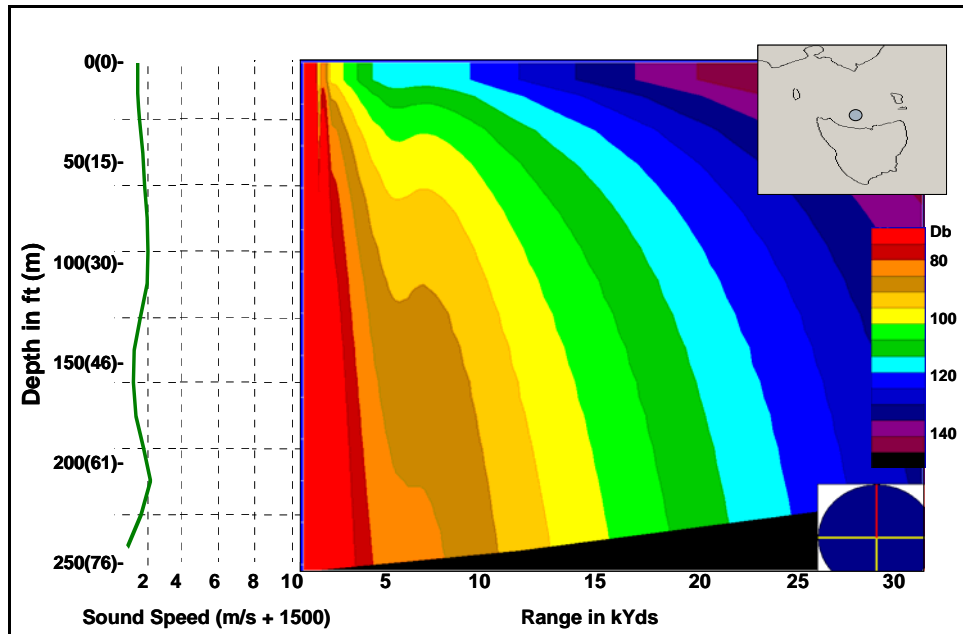


Figure 112: Winter Propagation Loss in Bass Strait, LAT 40 50S LON 146 25E

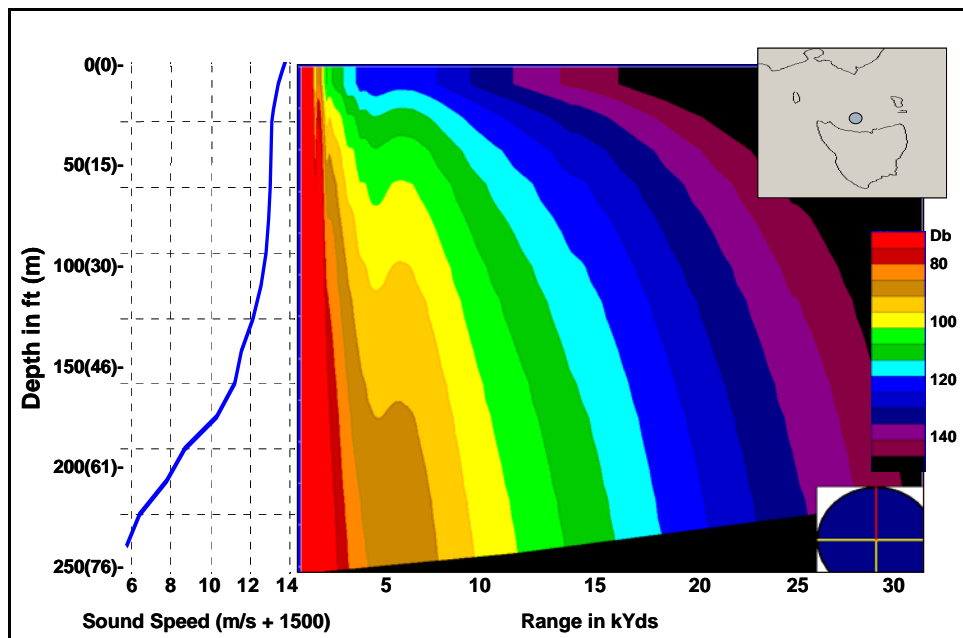


Figure 113: Summer Propagation Loss in Bass Strait, LAT 40 50S LON 146 25E

Due to the decreased propagation ranges in the Bass Strait during the summer, it was determined to use summer propagation curves to determine appropriate detection ranges. Using the same inputs as above, the resulting expected detection ranges are shown in Figure 114.

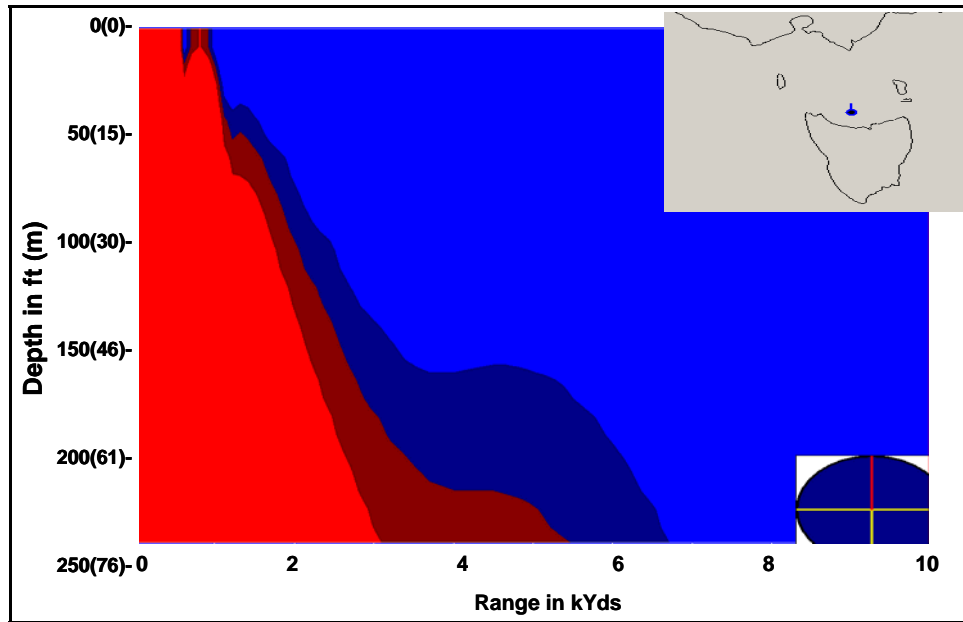


Figure 114: Expected Detection Ranges in Southern Bass Strait, LAT 40 50S LON 146 25E

Various areas throughout the Bass Strait were also considered to determine what variation, if any, may be noticed in the detection ranges. No noticeable variation was determined to exist across the Bass Strait during the summer months, as shown below in Figure 115.

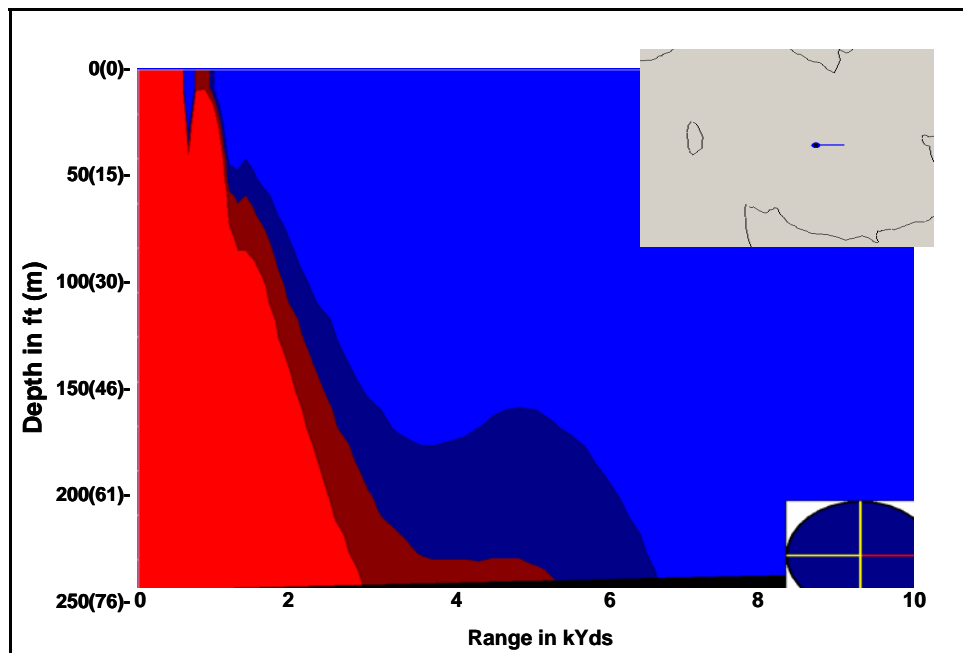


Figure 115: Expected Detection Range in Middle of Bass Strait, LAT 40 00S LON 146 30E

Other areas of possible interest were analyzed to determine how the expected detection range of the enemy AIP submarine compares with the Bass Strait. Two areas considered were the Java Sea (LAT 04 32S LON 113 07E) and the coast of South Korea (LAT 37 54N LON 129 30E). The expected detection ranges for both locations are shown in Figures 116 and 117. Note that the expected detection ranges in the Bass Strait and Java Sea are much more limiting than those found in the deeper region off of the Korean Peninsula.

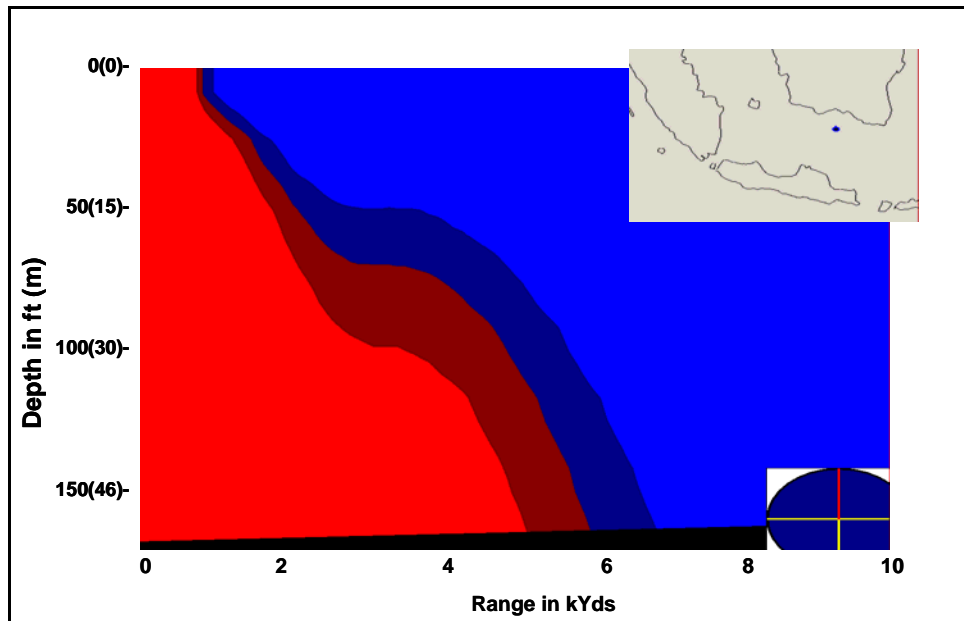


Figure 116: Expected Detection Range in Java Sea, LAT 04 32S LON 113 07E

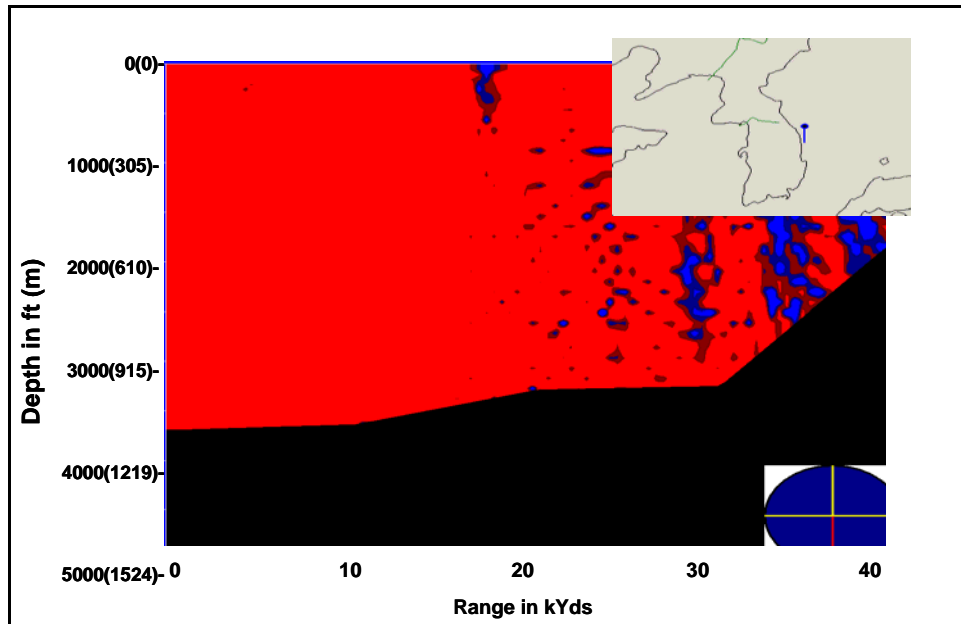


Figure 117: Expected Detection Range off Coast of South Korea, LAT 37 54N LON 129 30E

#### 3.4.4.2 NSS Study Plan Development

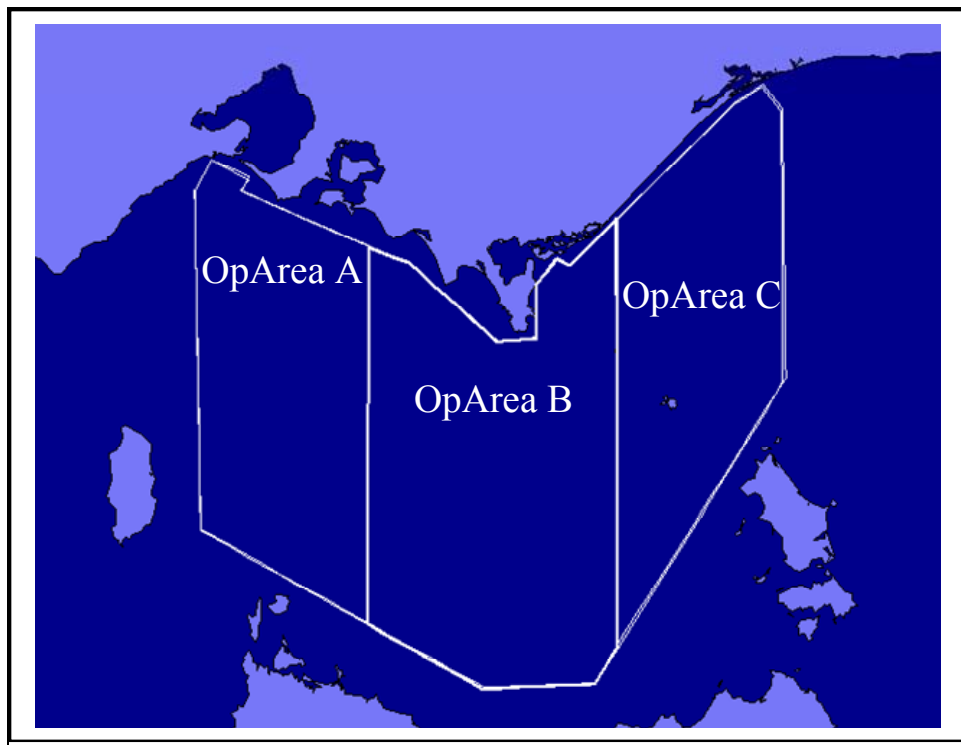
The specifics of the ASW scenario used for modeling, such as geographic location and number of enemy submarines, were determined by SEA-8. Required model and data preparation followed directly from the team-generated scenario. Data to be used as model inputs included both friendly and hostile (Blue and Red) platform and system characteristics, abilities, vulnerabilities, and tactics. This information was provided as a result of the research done by the SEA-8 teams.

The Prosecution Modeling Team first built a pilot study, which involved a reduced version of the baseline scenario. This reduced scenario included all of the significant warfare interactions, though with fewer numbers of entities compared with the full scenario. The reduced scenario was presented to the SEA-8 Board of Advisors as a proof-of-concept study plan, data collection effort, and model preparation effort for approval before proceeding to study the full scenario. This preview allowed for valuable feedback and recommendations on the scenario itself, operational plans, tactics used, and metrics considered prior to moving on with the study.

The Modeling Team constructed a Red force structure with associated doctrine, tactics, operations, schedule, and vulnerabilities. This structure was held constant for all alternatives and replications.

3.4.4.2.1 RED FORCE. The makeup of the Red alliance consisted of two AIP submarines moored in each of three harbors (A, B, and C). Additionally, there were two AIP submarines underway within the Red operational area. Each scenario starts with the Red assets in place as described.

When the simulation was commenced, all moored submarines get underway at a specified time and proceed with a 5-knot transit speed until they reach their designated OPAREA. Red submarines from Harbor A were tasked to patrol in OPAREA A, while Red submarines from Harbor B patrolled in OPAREA B, and so on. Patrols were conducted with random motion at a speed of 5 knots. The two Red submarines already underway started with a 6-knot, random-motion patrol and maintained this for the duration of the 30-day scenario. Table 17 indicates when each specific Red asset got underway and proceeded with its assigned mission. Details of the operational areas can be seen in the Figure 118.



**Figure 118: Bass Strait Showing Red OPAREAs A, B, and C**

All Red submarines were vulnerable to passive acoustic sensors, active acoustic sensors, and to radar detection when at periscope or snorkel depth. These

vulnerabilities were directly linked to a unique signature that will identify them as hostile to Blue forces and a track was initiated.

Red Platform	U/W Hour	Mission
AIP-A2	36	Proceed on track to OPAREA A and commence a random patrol
AIP-C1	53	Proceed on track to OPAREA C and commence a random patrol
AIP-B2	67	Proceed on track to OPAREA B and commence a random patrol
AIP-A1	86	Proceed on track to OPAREA A and commence a random patrol
AIP-C2	103	Proceed on track to OPAREA C and commence a random patrol
AIP-B1	120	Proceed on track to OPAREA B and commence a random patrol
AIP-U1	0	Commence random patrol throughout OPAREAs A, B, or C
AIP-U2	0	Commence random patrol throughout OPAREAs A, B, or C

**Table 17: Red Submarine Underway Time and Mission**

3.4.4.2.2 BLUE FORCE. Blue force composition is alternative/scenario dependent. Alternative 1 (Tripwire) consisted of UUVs and Seaweb-based sensors. Alternative 2 (TSSE) consisted of a TSSE-designed ship that deployed specially designed UUVs to deploy approximately 4,500 floating sensors. Alternative 3 (War of Machines) consisted solely of UUVs and Alternative 4 (LAG) consisted of the DD(X), LCS, and Virginia-class submarines. Tables 18 to 21 indicate the type of assets in each alternative, the number, the sensor utilized, search speed, and the 0.5 Pd detection range.

**ALTERNATIVE 1: TRIPWIRE:** At 24 hours into the simulation, 50 SWBSs were randomly air-dropped into a 10 NM x 10 NM area outside of each of the three harbors where the Red enemy submarines were ported. At hour 36, 5 Blue UUVs were air-dropped into each harbor. Each UUV had a lifespan of 80 hours before their batteries were completely discharged and no longer functional. Three days later, 2 Virginia-class submarines arrived into the OPAREA.

Asset Type	# Utilized	Sensor Type	0.5 Pd Range (NM)	Search Speed (kts)
UUV	15	Passive Acoustic Sonar	2	Trail at <10 kts
SWBS	150	Passive Acoustic Sonar	0.5	N/A
N/A = Not Applicable.				

**Table 18: Alternative 1 (Tripwire) Blue Asset Capabilities**

**ALTERNATIVE 2: TSSE Sea TENTACLE:** The TSSE alternative utilized three TSSE-designed ships that arrived in the OPAREA on Day 6, and then deployed some combination of large, heavyweight, light-weight, and/or



man-portable UUVs that would deploy a distributed network of sensors throughout the entire OPAREA on Day 8.

Asset Type	# Utilized	Sensor Type	0.5 Pd Range (NM)	Search Speed (kts)
TSSE Ship	3	Passive Acoustic Sonar	2	10
		Active Acoustic Sonar	3	
		Towed Array	2	
Large UUV	300	N/A	0.5	5
Heavyweight UUV	900	N/A	N/A	5
Light-weight UUV	4,500	N/A	N/A	5
Man-portable UUV	4,500	N/A	N/A	5
UUV-Deployed Sensor	4,500	Passive Acoustic Sonar	0.25	Stationary
N/A = Not Applicable.				

**Table 19: Alternative 2 (TSSE Sea TENTACLE) Blue Asset Capabilities**

**ALTERNATIVE 3: WAR OF MACHINES:** At Hour 8, 17 UUVs were air-dropped into the OPAREAS A, B and C. At Hour 18, 17 more UUV’s were air-dropped in. At Hour 20, 10 more UUVs were air-dropped, and, at Hour 26, the remaining 7 UUVs were air dropped into the OPAREA. From the initial air-drop, 2 UUVs were then deployed directly into each of Red’s harbors.

Recharging stations were inserted with the air-drops to maintain a schedule of 40 hours of search/tracking operations and 8 hours of recharging for each UUV. All UUVs conducted area searches in their assigned OPAREAs, while recharging on a rotating basis to maximize the number of operating UUVs.

Table 20 shows the number of assets used in the War of Machines alternative and their respective attributes of detection range (Pd) and search speed (kts).

Asset Type	# Utilized	Sensor Type	0.5 Pd Range (NM)	Search Speed (kts)
UUV	51	Passive Acoustic Sonar	2	5

**Table 20: Alternative 3 (War of Machines) Blue Asset Capabilities**

**ALTERNATIVE 4: LAG:** On Day 5, 1 Virginia-class submarine entered the OPAREA and commenced an area search. Day 6 brought the rest of the LAG into the OPAREA. The DD(X) utilized onboard sensors and commenced an area search within its assigned box with the aid of an embarked SH-60R and its own organic ASW sensors. All 3 LCS-class ships entered the OPAREA and commenced ladder searches within their assigned box, using onboard sensors that utilized embarked SH-60R helicopters with their own organic ASW assets. Simultaneously, the remaining SSN entered the OPAREA and commenced an area search.

<b>Asset Type</b>	<b># Utilized</b>	<b>Sensor Type</b>	<b>0.5 Pd Range (NM)</b>	<b>Search Speed (kts)</b>
DDX	1	Passive Acoustic Sonar	2	10
		Active Acoustic Sonar	3	10
		Phased Array Radar	7	10
LCS	3	Passive Acoustic Sonar	2	10
		Active Acoustic Sonar	3	10
		Radar	7	10
SSN Virginia Class	2	Passive Acoustic Sonar	4	10
		Active Acoustic Sonar	4	10
		Towed Array	5	10
SH-60R	4 (one per ship)	Radar (Surface Search)	10	80
		FLIR	4	80
		Active/Passive Sonar (Dipping)	2	N/A

**Table 21: Alternative 4 (LAG) Blue Asset Capabilities**

## 4.0 RESULTS, INSIGHTS, AND CONCLUSIONS

### 4.1 INTRODUCTION

SEA-8 has generated insights into the future of littoral ASW during the problem definition, modeling, and analysis phases of the SEDP. By comparing five distinct alternative architectures, SEA-8 was able to identify which aspects of each alternative are critical to its success as well as to quantify the value of each solution's strength and weakness. From their work, SEA-8 developed the following conclusions:

- Future unmanned technologies will require the use of an underwater joint engagement zone. Although the current method of managing submerged Blue assets in hostile waters is adequate, the future of ASW will require a new standard of coordination in the underwater engagement zone, demanding the identification of unmanned mobile platforms with frequency-agile acoustic identification of friend/foe (IFF) and broadcasting frequent Blue location data to manned systems
- Speed is required if the enemy is to be caught when he is most vulnerable. Rapidly deployable detection systems must be used to establish trail during the enemy's exposed transit through port channels or the enemy must be detected in the more challenging setting of the littoral or open-ocean environments
- The constant presence of detection systems is required in the area of regard to effectively perform ASW. The ability to achieve undersea control is dependent on employing persistent detection systems or complementing short-lived systems with persistent assets in a timely manner
- Traditional manned trailing assets require onboard weapons systems to effectively engage the quiet enemy of the future. Yet, invasive, unmanned, trailing systems are compatible with standoff weapons. Unmanned sensors that are capable of performing close-aboard trail of enemy submarines work well with standoff weapons that experience a longer kill timeline. However, traditional manned systems that trail from a longer distance will

experience an increased probability of losing track against future, quieter threats and therefore must employ on-board weapons to engage the enemy or integrate with off-board sensors to extend their reach

#### **4.2 FUTURE OPERATIONS IN THE UNDERWATER ENGAGEMENT ZONE**

Current and historic ASW operations by submerged Blue assets have required waterspace management and the Prevention of Mutual Interference (PMI) to prevent Blue-on-Blue engagement and underwater collisions.

With the advent of UUVs, the number of Blue submerged assets will increase in the antisubmarine operations area. It is the opinion of SEA-8 that the current method of conducting waterspace management and PMI will prove to be too administratively burdensome and time consuming, and will be incapable of the timely adaptation required in the future Underwater Engagement Zone (UEZ), thereby resulting in an unacceptably high probability of fratricide.

Current methods of waterspace management and PMI are required because the exact locations of Blue underwater assets are unknown by other Blue platforms. Therefore, today's waterspace management procedures require the assignment of large boxes of water (or depth-layers of large boxes of water) to specific Blue submarines. In the future, such broad designations of water for all submerged assets will not be acceptable as the number of platforms increases inside a finite area. Smaller boxes of water may be utilized; however, smaller operating areas will stress the need for precise location knowledge onboard each asset and still severely limit the number of assets able to operate inside a given area.

Engagement tactics for PMI will also be made more difficult by an increase in the number of submerged Blue platforms. Current doctrine allows for the designation of boxes of water to be free of friendly submarines so that any detected submerged platform may be assumed hostile. However, such boxes will greatly limit the use of unmanned vehicle trailing abilities, forcing them to break-trail in order to avoid entering established kill-boxes. Using the full ability of this trailing resource would allow for direct attack on a known enemy location, while knowing the location of other Blue assets to be at a safe distance.

Given the increase in submerged platform numbers and types that are likely to operate in an ASW area, it is the opinion of SEA-8 that operations will require immediate IFF for all unmanned platforms when queried. This may be done clandestinely. However, clandestine IFF responses may not be required for unmanned systems if the tactical risk is considered minimal.

Although waterspace management and PMI may still be required for manned systems, UUVs should be allowed to operate with impunity throughout the ASW operating area. They should possess a frequency-agile acoustic signature that will permit their detection and identification by manned assets, thereby preventing collisions. In kill-boxes, the UUVs identification should be readily perceivable by the same method while the expected loss of UUVs due to the engagement of Red submerged assets should be accepted.

#### **4.3 THE IMPORTANCE OF ARRIVAL TIMELINE**

A submarine leaving port is not required to transit on the surface through its harbor. Many small submarines are capable of submerging at the pier. However, even the submerged submarine must transit through the restricted waters of the port's entrance/exit channel to transition from the pier to the broader waters of its operational area to disappear in the vast ocean. For this reason, an enemy submarine force is most vulnerable when it has not yet arrived in the open waters of its operating area. If the submarine is not detected during this highly susceptible and restricted transit, then detection must be achieved in the more difficult setting of the littoral or open ocean environments.

In order to capitalize on this vulnerability, Blue assets must be on-station, ready to detect a departing enemy submarine. The uncertainty of when the Red submarines will leave port requires hedging by Blue forces (i.e., arriving early in the chokepoints of the submarine's departure path). Many ports may need to be monitored and the work is sensitive due to the proximity to the sovereign waters of foreign nations.

For these reasons, the use of waterborne, manned systems will not be capable of achieving a desirable Pd. However, small, relatively inexpensive, unmanned systems that may be covertly placed inside enemy departure chokepoints by airborne assets can provide the Blue arrival timeline essential to hedge against the uncertainty of Red

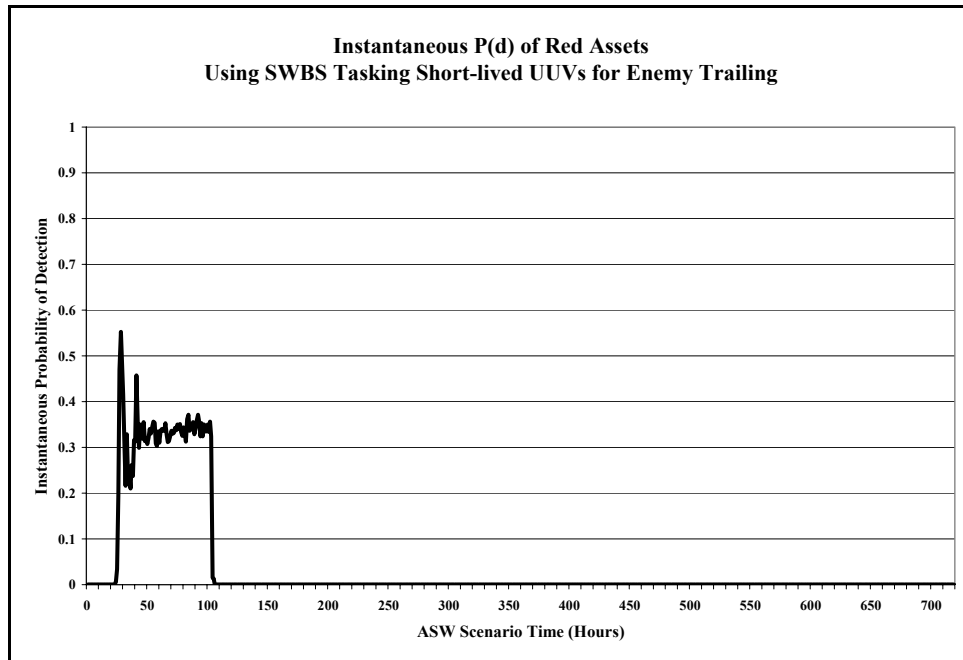
departure schedules. Due to their low cost, such assets may be placed in numerous locations near many ports, thereby hedging against the uncertainty of which ports are actively deploying enemy submarines.

#### **4.4 THE NEED FOR PERSISTENT SYSTEMS**

Detection of the submerged enemy asset at any point in its patrol is most valuable if its location can continue to be known throughout the scenario. For this reason, the placement of stationary sensors is adequate only if the entire AOR is covered. Assets, such as UUVs, capable of trailing the submarine or attaching a tracking device that will communicate location to Blue forces may also be used to perform this mission. However, to be effective, the solution must be persistent throughout the scenario.

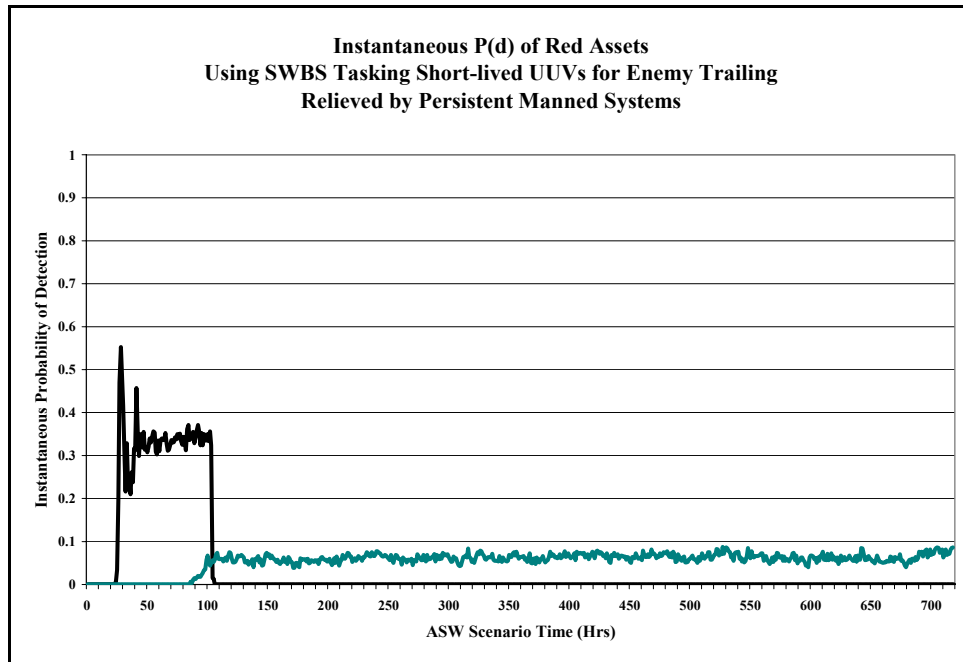
The status of power-storage technology today does not show promise for providing the power density required to drive unmanned vehicles throughout week-long ASW scenarios. For this reason, one of the following solutions must be applied to the use of unmanned systems in ASW: (1) the capability to recharge area assets must be supplied; (2) the cost of systems must be low, providing the ability to reseed the AOR as needed; or (3) manned, persistent systems must arrive in time to relieve unmanned systems before their power sources are depleted.

The benefit of providing trailing UUVs tasked by SWBS at the mouth of enemy ports is clearly seen in Figure 119. However, due to their limited endurance, the probability of knowing where the submerged enemy is after a few days is unlikely.



**Figure 119: The Inability of Nonpersistent Systems to Provide the Location of Enemy Forces Throughout the ASW Scenario is Evident**

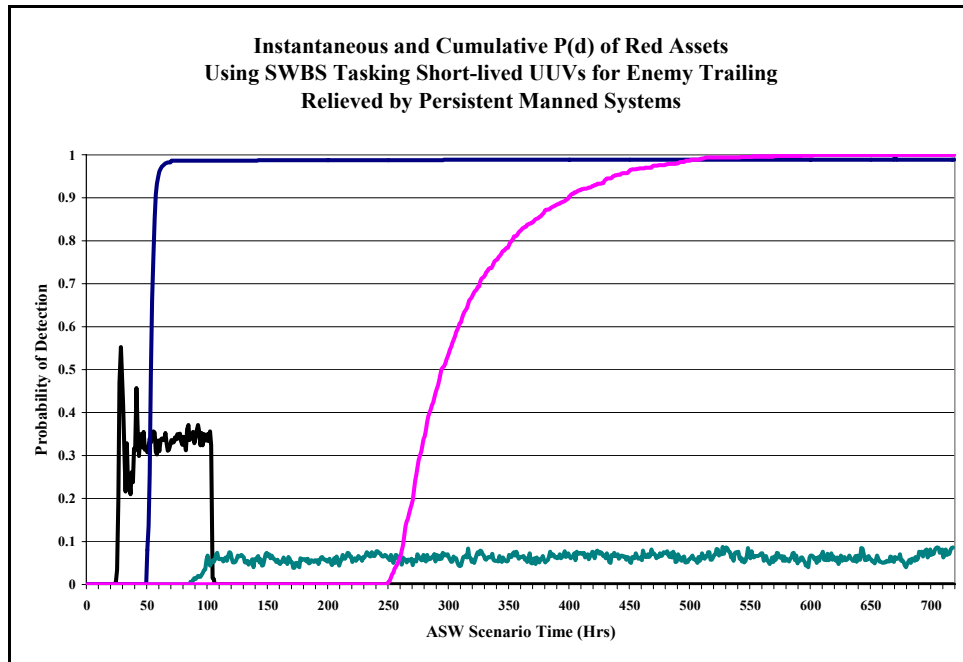
In order to track the enemy's location throughout the scenario, the employment of manned systems may be used. In Figure 120, the arrival of conventional, manned platforms can be seen to augment the capability of the combined systems throughout the entire ASW scenario.



**Figure 120: By Combining the Short-Lived UUVs With a Persistent Manned System, Enemy Detection can be Sustained Throughout the ASW Scenario**

Alone, each system would prove to be of limited value, ceasing to work before the completion of the conflict or arriving too late to detect the enemy submarines during their vulnerable departure from port. Together, the solutions combine to create an effective, timely, and persistent SoS in the ASW battle. Using the proposed alternatives, any Red submarine leaving port after Day 1 will possess a high probability of being detected shortly after leaving port. This is indicated on Figure 121, with the cumulative probability of being detected at or prior to time  $t$ . Two scenarios are shown, with one enemy submarine entering the AOR at time 50 hours and another entering at time 250 hours.





**Figure 121: The Instantaneous and Cumulative Probability of Detection of an Enemy Submarine Leaving Port**

#### **4.5 STANDOFF WEAPONS AND UNMANNED SYSTEMS**

Due to the great strategic cost of losing a manned submarine in enemy waters, submarine doctrine will require trailing of Red submarines from a distance that will keep the manned Blue platform outside of the enemy’s expected counter-detection range. Given the future capabilities of Red AIP submarines in both detection capability and low acoustic signature, it is believed that Blue forces will have a difficult time maintaining continuous track without the use of off-board sensors. Instead, trailing will provide frequent, but sporadic, detections of the Red platform.

This method of trail is not conducive to the use of standoff weapons that require a long kill timeline to engage the enemy. For this reason, onboard weapons systems will still be required for manned submarines.

However, due to their smaller acoustic signature and lower strategic value, UUVs are capable of trailing enemy submarines at a much closer range than conventional manned systems. This decrease in trailing range will allow the unmanned system to maintain a higher probability of continuous track against submerged enemy forces.

Standoff weapons may then be used with an acceptable probability of success, receiving track updates from the associated UUV throughout the kill timeline. Using

unmanned systems for trail, the probability of maintaining track of the enemy is not affected by increased in kill timeline length (Figure 122).

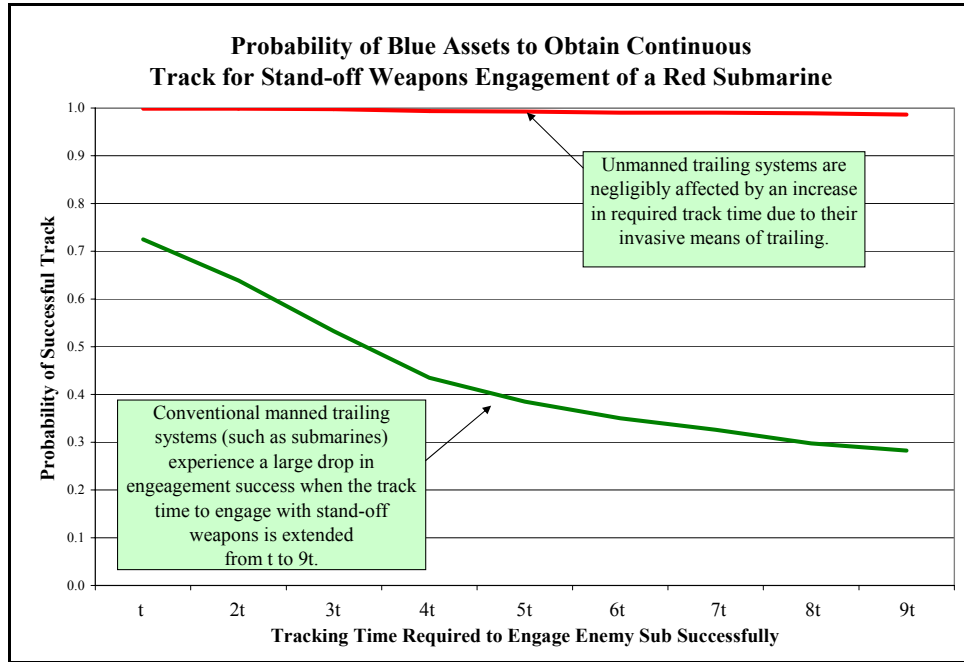


Figure 122: The Trade-Off Between Trailing Range and Acceptable Kill-Chain Timelines is Critical

## GLOSSARY

**3M Manual:** OPNAVINST 4790.10D. To establish policy and assign responsibilities for the Ships' 3-M System in accordance with OPNAVINST 4700.7K, Maintenance Policy for U.S. Navy Ships and SECNAVINST 4790.1, Department of the Navy Maintenance and Material Management (3-M) System; policy for this instruction is a complete revision and should be reviewed in its entirety.<sup>196</sup>

**Air Superiority:** That degree of dominance in the air battle of one force over another which permits the conduct of operations by the former and its related land, sea and air forces at a given time and place without prohibitive interference by the opposing force. (DOD)<sup>197</sup>

**Air Supremacy:** The degree of air superiority wherein the opposing air force is incapable of effective interference. (DOD)<sup>198</sup>

**Air/Surface Distance:** The maximum distance between a transmitter and a receiver where usable signal can be detected measured in nautical miles.<sup>199</sup>

- NM – 6,000 feet, 2,000 yards

**Antisubmarine Warfare:** Operations conducted with the intention of denying the enemy the effective use of their submarines. (DOD)<sup>200</sup>

**Architecture:** The structure of components, their relationships, and the principles and guidelines governing their design and evolution over time. (DOD)<sup>201</sup>

**Area of Operations (AO):** An operational area defined by the joint force commander for land and naval forces. Areas of operation do not typically encompass the entire operations area, but are large enough for component commanders to accomplish their missions and protect their forces. (DOD)<sup>202</sup>

---

<sup>196</sup> [http://www.spear.navy.mil/OPNAV/OPNAVINST\\_4790\\_4D\\_3M%20Policy\\_28AUG03.doc](http://www.spear.navy.mil/OPNAV/OPNAVINST_4790_4D_3M%20Policy_28AUG03.doc), (accessed 30 November 2005).

<sup>197</sup> Joint Chiefs of Staff, Department of Defense Dictionary of Military and Associated Terms, Joint Publication 1-02, (Washington, DC: 12 April 2001 (as amended through 31 August 2005)), p. 28.

<sup>198</sup> Ibid.

<sup>199</sup> M.B. Porter, F.B. Jensen, and N.G. Pace, "High-Frequency Propagation for Acoustic Communications," *Impact of Littoral Environmental Variability on Acoustic Predictions and Sonar Performance*. (Kluwer Academic Publishers: 2002)

<sup>200</sup> Joint Chiefs of Staff, Department of Defense Dictionary of Military and Associated Terms, Joint Publication 1-02, (Washington, DC: 12 April 2001 (as amended through 31 August 2005)), p. 40.

<sup>201</sup> Ibid., p. 42.

<sup>202</sup> Ibid., p. 44.

**Availability:** The probability that a repairable system is operational at a given point in time, under a given set of environmental conditions. Availability depends on reliability and maintainability.<sup>203</sup>

**Battlespace:** The environment, factors, and conditions that must be understood to successfully apply combat power, protect the force, or complete the mission. This includes the air, land, sea, space, and the included enemy and friendly forces; facilities; weather; terrain; the electromagnetic spectrum; and the information environment within the operational areas and areas of interest. See also electromagnetic spectrum; information environment; joint intelligence preparation of the battlespace. (DOD)<sup>204</sup>

**Battlespace Awareness:** Knowledge and understanding of the operational area's environment, factors, and conditions, to include the status of friendly and adversary forces, neutrals and noncombatants, weather and terrain, that enables timely, relevant, comprehensive, and accurate assessments, in order to successfully apply combat power, protect the force, and/or complete the mission. (DOD)<sup>205</sup>

**Bit Error Rate (BER):** The degree to which transmitted data truly reflects the intended content of the data when reconstructed following the transmission process, measured in percentage of bits transmitted with errors.<sup>206</sup>

**Clandestine Operation:** An operation sponsored or conducted by governmental departments or agencies in such a way as to assure secrecy or concealment. A clandestine operation differs from a covert operation in that emphasis is placed on concealment of the operation rather than on concealment of identity of sponsor. In special operations, an activity may be both covert and clandestine and may focus equally on operational considerations and intelligence-related activities. (DOD)<sup>207</sup>

**Commander's Intent:** A concise expression of the purpose of the operation and the desired end state that serves as the initial impetus for the planning process. It may also

---

<sup>203</sup> David Olwell and David Schradly, *OS 4580 Logistics Systems Analysis Course Notes* (Naval Postgraduate School, Monterey, CA: 2005).

<sup>204</sup> Joint Chiefs of Staff, Department of Defense Dictionary of Military and Associated Terms, Joint Publication 1-02, (Washington, DC: 12 April 2001 (as amended through 31 August 2005)), p. 64.

<sup>205</sup> Ibid.

<sup>206</sup> M.B. Porter, F.B. Jensen, and N.G. Pace "High-Frequency Propagation for Acoustic Communications," *Impact of Littoral Environmental Variability on Acoustic Predictions and Sonar Performance*. (Kluwer Academic Publishers: 2002).

<sup>207</sup> Joint Chiefs of Staff, Department of Defense Dictionary of Military and Associated Terms, Joint Publication 1-02, (Washington, DC: 12 April 2001 (as amended through 31 August 2005)), p. 89.

include the commander's assessment of the adversary commander's intent and an assessment of where and how much risk is acceptable during the operation. See also assessment; end state.<sup>208</sup>

**Common Operational Picture:** A single identical display of relevant information shared by more than one command. A common operational picture facilitates collaborative planning and assists all echelons to achieve situational awareness. (DOD)<sup>209</sup>

**Common Undersea Picture:** A single identical display of relevant information shared by more than one command. A common undersea picture facilitates collaborative planning and assists all echelons to achieve situational awareness. (DOD)<sup>210</sup>

**Communications Node:** The physical and functional grouping of communications and computer systems that provide terminating, switching, and gateway access services to support information exchange. (DOD)

**CONUS:** Continental United States

**Data Rate:** The speed with which data can be transmitted from one device to another. Data rates are often measured in megabits (million bits) per second. These are usually abbreviated as Mbps and MBps, respectively.<sup>211</sup>

- bps – bits per second
- kbps – 1000 bits per second
- Mbps – 1,000,000 bits per second
- Gbps – 1,000,000,000 bits per second

**Datum:** The last known position of a submarine, or suspected submarine, after contact has been lost. (DOD)<sup>212</sup>

**Defense-in-Depth:** The placing of mutually supporting defense positions designed to absorb and progressively weaken attack, prevent initial observations of the whole position by the enemy, and to allow the commander to maneuver the reserve. (DOD)<sup>213</sup>

---

<sup>208</sup> Department of Defense, *Dictionary of Military and Associated Terms*, 31 August 2005.

<sup>209</sup> <http://www.dtic.mil/doctrine/jel/doddict/data/c/01129.html>, (accessed 30 November 2005).

<sup>210</sup> <http://www.dtic.mil/doctrine/jel/doddict/data/c/01129.html>, (accessed 30 November 2005).

<sup>211</sup> M.B. Porter, F.B. Jensen, and N.G. Pace, "High-Frequency Propagation for Acoustic Communications," *Impact of Littoral Environmental Variability on Acoustic Predictions and Sonar Performance*. (Kluwer Academic Publishers: 2002).

<sup>212</sup> Joint Chiefs of Staff, *Department of Defense Dictionary of Military and Associated Terms*, Joint Publication 1-02, (Washington, DC: 12 April 2001 (as amended through 31 August 2005)), p. 143.

<sup>213</sup> *Ibid.*, p. 149.

**Deploy:** 1. In naval usage, the change from a cruising approach or contact disposition to a disposition for battle. 2. The movement of forces within operational areas of responsibility. 3. The positioning of forces into a formation for battle. 4. The relocation of forces and materiel to desired operational areas of responsibility. Deployment encompasses all activities from origin or home station through destination, specifically including Intra-Continental United States, inter-theater, and intra-theater movement legs, staging, and holding areas. See also deployment order; deployment planning; deployment preparation order. (JP 4-0)<sup>214</sup>

**Deployment:** The relocation of forces and materiel to desired operational areas. Deployment encompasses all activities from origin or home station through destination, specifically including intracontinental United States, intertheater, and intratheater movement legs, staging, and holding areas. (DOD)<sup>215</sup>

**Distributed Network:** A network structure in which the network resources, such as switching equipment and processors, are distributed throughout the geographical area being served. (188) Note: Network control may be centralized or distributed.<sup>216</sup>

**Effects Based Methodology or Operations:** A process for obtaining a desired strategic outcome or “effect” on the enemy, through the synergistic, multiplicative, and cumulative application of the full range of military and nonmilitary capabilities at the tactical, operational, and strategic levels.<sup>217</sup>

**Emission Control (EMCON):** Used to describe the intentional restriction in the use of radio transmissions.<sup>218</sup>

**End State:** The set of required conditions that defines achievement of the commander’s objectives. (DOD)<sup>219</sup>

**Explosive Ordnance Disposal Unit:** Personnel with special training and equipment who render explosive ordnance safe (such as bombs, mines, projectiles, and booby traps),

---

<sup>214</sup> Ibid., p. 28.

<sup>215</sup> Ibid., p. 156.

<sup>216</sup> <http://www.its.bldrdoc.gov/fs-1037/dir-012/1752.htm>, (accessed 30 November 2005).

<sup>217</sup> <http://www.jfcom.mil/about/glossary.htm#EBO>, (accessed 30 November 2005).

<sup>218</sup> Department of Defense, *Dictionary of Military and Associated Terms*, 31 August 2005.

<sup>219</sup> Joint Chiefs of Staff, *Department of Defense Dictionary of Military and Associated Terms*, Joint Publication 1-02, (Washington, DC: 12 April 2001 (as amended through 31 August 2005)), p. 184.

make intelligence reports on such ordnance, and supervise the safe removal thereof. (DOD)<sup>220</sup>

**Feasibility:** The determination as to whether the assigned tasks could be accomplished by using available resources. (DOD)<sup>221</sup>

**FORCENet:** The operational construct and architectural framework for Naval Warfare in the Information Age which integrates WARRIORS, sensors, networks, command and control, platforms and weapons into a networked, distributed combat force, scalable across the spectrum of conflict from seabed to space and sea to land.”\*

*\*CNO's Strategic Study Group - XXI definition from 22 July 02 CNO Briefing.*

**Full Mission Capable:** Material condition of any piece of military equipment, aircraft, or training device indicating that it can perform all of its missions. Also called FMC. (DOD)<sup>222</sup>

**Full Spectrum:** The ability of US forces, operating unilaterally or in combination with multinational and interagency partners, to defeat any adversary and control any situation across the full range of military operations.

**Global Information Grid (GIG):** A net-centric system operating in a global context to provide processing, storage, management, and transport of information to support all Department of Defense (DOD), national security, and related intelligence community missions and functions-strategic, operational, tactical, and business-in war, in crisis, and in peace.<sup>223</sup>

**Graceful Degradation:** Degradation of a system in such a manner that it continues to operate, but provides a reduced level of service rather than failing completely.<sup>224</sup>

**High Density Field:** A sensor field for the System of Systems that requires 41 sensors per 10 NM x 10 NM reseeded every 8 hours over a 30 day period.

**HyperSoar:** The Falcon (formerly HyperSoar) program objectives are to develop and demonstrate hypersonic technologies that will enable the capability to execute prompt global reach missions. This capability is envisioned to entail a reusable, Hypersonic Cruise Vehicle (HCV) capable of delivering 12,000 pounds of payload a distance of

---

<sup>220</sup> Ibid., p. 194.

<sup>221</sup> Ibid., p. 198.

<sup>222</sup> Ibid., p. 219.

<sup>223</sup> [http://akss.dau.mil/dag/Guidebook/IG\\_c7.2.asp](http://akss.dau.mil/dag/Guidebook/IG_c7.2.asp), (accessed 30 November 2005.)

<sup>224</sup> [http://www.its.bldrdoc.gov/fs-1037/dir-017/\\_2479.htm](http://www.its.bldrdoc.gov/fs-1037/dir-017/_2479.htm), (accessed 30 November 2005.)

9,000 NM from CONUS in less than two hours. The technologies required by an HCV include high lift-to-drag technologies, high temperature materials, thermal protection systems, and guidance, navigation, and control. Leveraging technology developed under the Hypersonic Flight (HyFly) program, Falcon will address the implications of hypersonic flight and reusability using a series of Hypersonic Technology Vehicles (HTVs) to incrementally demonstrate these required technologies in flight. In order to implement this flight test program in an affordable manner, Falcon will develop a low cost, responsive Small Launch Vehicle (SLV) that can be launched for \$5M or less. In addition to Hypersonic Technology Vehicles (HTV) sub-orbital launches, the SLV will be capable of launching small satellites into sun-synchronous orbits and will provide the nation a new, small payload access to space capability. Thus, the Falcon program addresses many high priority mission areas and applications such as global presence and space lift. DARPA established an MOA with NASA for this program in October 2004. Falcon capabilities are planned for transition to the Air Force at the conclusion of Phase III, which is anticipated to be completed by FY 2010.<sup>225</sup>

**Information Assurance:** Information operations that protect and defend information and information systems by ensuring their availability, integrity, authentication, confidentiality, and nonrepudiation. This includes providing for restoration of information systems by incorporating protection, detection, and reaction capabilities. Also called IA. (DOD)<sup>226</sup>

**Information Operations:** Actions taken to affect adversary information and information systems while defending one's own information and information systems. Also called IO. (DOD)<sup>227</sup>

**Information Operations Condition (INFOCON):** Used to describe the intentional flow of information, generally unclassified, allowed through communications systems.<sup>228</sup>

**Information System Requirements:** Those items of information regarding the adversary and the environment that need to be collected and processed in order to meet the intelligence requirements of a commander. (DOD)<sup>229</sup>

---

<sup>225</sup> <http://www.darpa.mil/tto/programs/falcon.htm>, (accessed 30 November 2005).

<sup>226</sup> Joint Chiefs of Staff, *Department of Defense Dictionary of Military and Associated Terms*, Joint Publication 1-02, (Washington, DC: 12 April 2001 (as amended through 31 August 2005)), p. 258.

<sup>227</sup> *Ibid.*, p. 259.

<sup>228</sup> Department of Defense, *Dictionary of Military and Associated Terms*, 31 August 2005.



**Information Superiority:** That degree of dominance in the information domain which permits the conduct of operations without effective opposition. (DOD)<sup>230</sup>

**Information Warfare:** Information operations conducted during time of crisis or conflict to achieve or promote specific objectives over a specific adversary or adversaries. Also called IW. (DOD)<sup>231</sup>

**Intelligence, Surveillance, and Reconnaissance:** An activity that synchronizes and integrates the planning and operation of sensors, assets, and processing, exploitation, and dissemination systems in direct support of current and future operations. This is an integrated intelligence and operations function. Also called ISR. (DOD)<sup>232</sup>

**Interoperability:** 1. The ability of systems, units, or forces to provide services to and accept services from other systems, units, or forces and to use the services so exchanged to enable them to operate effectively together. 2. The condition achieved among communications-electronics systems or items of communications-electronics equipment when information or services can be exchanged directly and satisfactorily between them and/or their users. (DOD)<sup>233</sup>

**Iridium:** Company that is a provider of global satellite voice and data solutions with complete coverage of the earth (including oceans, airways and Polar Regions). Iridium delivers essential communications services to and from remote areas where no other form of communication is available. The Iridium constellation of 66 low-earth orbiting (LEO), cross-linked satellites operates as a fully meshed network and is the largest commercial satellite constellation in the world. The Iridium service is ideally suited for industries such as maritime, aviation, government/military, emergency/humanitarian services, mining, forestry, oil and gas, heavy equipment, transportation and utilities.<sup>234</sup>

**JELO:** Joint Expeditionary Logistics Operations Model.

---

<sup>229</sup> Joint Chiefs of Staff, Department of Defense Dictionary of Military and Associated Terms, Joint Publication 1-02, (Washington, DC: 12 April 2001 (as amended through 31 August 2005)), p. 259.

<sup>230</sup> Ibid., p. 259.

<sup>231</sup> Ibid., p. 259.

<sup>232</sup> Ibid., p. 269.

<sup>233</sup> Ibid., p. 274.

<sup>234</sup> Iridium Co., "About Iridium-Our Story," [http://www.iridium.com/corp/iri\\_corp-understand.asp](http://www.iridium.com/corp/iri_corp-understand.asp).

**Joint Operations:** A general term to describe military actions conducted by joint forces or by Service forces in relationships (e.g., support, coordinating authority) which, of themselves, do not create joint forces. (DOD)<sup>235</sup>

**Joint Operations Area:** An area of land, sea, and airspace, defined by a geographic combatant commander or subordinate unified commander, in which a joint force commander (normally a joint task force commander) conducts military operations to accomplish a specific mission. Joint operations areas are particularly useful when operations are limited in scope and geographic area or when operations are to be conducted on the boundaries between theaters. Also called JOA. (DOD)<sup>236</sup>

**Littoral:** Encompasses ocean environments that extend from shoreline out to 100 NM.

**Logistic Support:** Logistic support encompasses the logistic services, materiel, and transportation required to support the continental United States-based and worldwide deployed forces. (DOD)<sup>237</sup>

**Low Density Field:** A sensor field for the System of Systems that requires 25 sensors per 10NM x 10NM box reseeded every 8 hours over a 30 day period.

**Maintainability:** The probability that an item can be repaired in a defined environment within a specified period of time. Increased maintainability implies shorter repair times.<sup>238</sup>

**Man Portable:** Capable of being carried by one man. Specifically, the term may be used to qualify: 1. Items designed to be carried as an integral part of individual, crew-served, or team equipment of the dismounted soldier in conjunction with assigned duties. Upper weight limit: approximately 14 kilograms (31 pounds.) 2. In land warfare, equipment which can be carried by one man over long distance without serious degradation of the performance of normal duties. (DOD)

**Measures of Effectiveness (MOEs):** MOEs are most often subjective indicators that the outcomes of the “tactical actions” have achieved, or contributed to achieving the desired

---

<sup>235</sup> Joint Chiefs of Staff, Department of Defense Dictionary of Military and Associated Terms, Joint Publication 1-02, (Washington, DC: 12 April 2001 (as amended through 31 August 2005)), p. 289.

<sup>236</sup> Ibid., p. 289.

<sup>237</sup> Ibid., p. 313.

<sup>238</sup> David Olwell and David Schradly, *OS 4580 logistics Systems Analysis Course Notes* (Naval Postgraduate School, Monterey, CA: 2005).

effect. MOE articulate where to look and what to measure in order to determine if the desired effect has been achieved.<sup>239</sup>

**Measures of Performance (MOP):** The objective metrics of the “outcomes” of “tactical actions,” MOP are assessed at the component level as a result of the “tactical actions” performed to achieve a desired effect, i.e., were the targets hit and what level of damage was achieved.<sup>240</sup>

**Modularity:** A force design methodology that establishes a means to provide interchangeable, expandable, and tailor-able force elements.<sup>241</sup>

**Moore’s Law:** Law that implies that the processing power of each integrated circuit card doubles every eighteen months. The number of transistors per square inch contained on an integrated circuit card has doubled every 18 months since the integrated circuit card was invented.<sup>242</sup>

**Naval Aviation Maintenance Program (NAM) Manual:** This instruction outlines command, administrative and management relationships and establishes policies and procedures for the assignment of maintenance responsibilities and tasks. It is the basic document and authority governing the management of all naval aviation maintenance. All directives and instructions in conflict with the provisions of this instruction shall be revised to ensure conformity.<sup>243</sup>

**National Emergency:** A condition declared by the President or the Congress by virtue of powers previously vested in them that authorize certain emergency actions to be undertaken in the national interest. Action to be taken may include partial, full, or total mobilization of national resources. (DOD)<sup>244</sup>

---

<sup>239</sup> Joint Chiefs of Staff, Department of Defense Dictionary of Military and Associated Terms, Joint Publication 1-02, (Washington, DC: 12 April 2001 (as amended through 31 August 2005)), p. 331.

<sup>240</sup> <http://www.jfcom.mil/about/glossary.htm#EBO>.

<sup>241</sup> [http://www.sec.army.mil/arat/ARAT/ARAT\\_information/arat\\_terms/module.htm](http://www.sec.army.mil/arat/ARAT/ARAT_information/arat_terms/module.htm), (accessed 30 November 2005).

<sup>242</sup> ARS Technia, “Understanding Moore’s Law,” <http://arstechnica.com/articles/paedia/cpu/moore.ars/1>.

<sup>243</sup> [http://www.iiimef.usmc.mil/medical/FMF/FMFE/FMFEref/OPNAVINST%204790\\_2H%20BASIC%20INSTRUCTION.txt](http://www.iiimef.usmc.mil/medical/FMF/FMFE/FMFEref/OPNAVINST%204790_2H%20BASIC%20INSTRUCTION.txt), (accessed 30 November 2005).

<sup>244</sup> Joint Chiefs of Staff, Department of Defense Dictionary of Military and Associated Terms, Joint Publication 1-02, (Washington, DC: 12 April 2001 (as amended through 31 August 2005)), p. 360.

**National Military Strategy:** The art and science of distributing and applying military power to attain national objectives in peace and war. Also called NMS. (DOD)<sup>245</sup>

**OCONUS:** Outside Continental United States.

**On-Station Time:** The time an asset can remain on station. May be determined by endurance or orders. (DOD)<sup>246</sup>

**Operational Area:** An overarching term encompassing more descriptive terms for geographic areas in which military operations are conducted. Operational areas include, but are not limited to, such descriptors as area of responsibility, theater of war, theater of operations, joint operations area, amphibious objective area, joint special operations area, and area of operations. (DOD)<sup>247</sup>

**Operational Condition (OPCON):** Used to describe the degree to which a platform or unit is ready for combat operations.<sup>248</sup>

**Operational Evaluation (OPEVAL):** The test and analysis of a specific end item or system, insofar as practicable under service operating conditions, in order to determine if quantity production is warranted considering: A. The increase in military effectiveness to be gained; and B. Its effectiveness as compared with currently available items or systems, consideration being given to: (1) personnel capabilities to maintain and operate the equipment; (2) size, weight, and location considerations; and (3) enemy capabilities in the field.<sup>249</sup>

**Order of Battle:** The identification, strength, command structure, and disposition of the personnel, units, and equipment of any military force. Also called OB; OOB. (DOD)

**Organic:** Assigned to and forming an essential part of a military organization. Organic parts of a unit are those listed in its table of organization for the Army, Air Force, and Marine Corps, and are assigned to the administrative organizations of the operating forces for the Navy.<sup>250</sup>

**Partial Mission Capable:** Material condition of an aircraft or training device indicating that it can perform at least one but not all of its missions. Also called PMC. (DOD)

---

<sup>245</sup> Ibid., p. 361.

<sup>246</sup> Ibid., p. 388.

<sup>247</sup> Ibid., p. 389.

<sup>248</sup> Department of Defense, *Dictionary of Military and Associated Terms*, 31 August 2005.

<sup>249</sup> Joint Chiefs of Staff, *Department of Defense Dictionary of Military and Associated Terms*, Joint Publication 1-02, (Washington, DC: 12 April 2001 (as amended through 31 August 2005)), p. 390.

<sup>250</sup> Ibid., p. 395.

**Payload Capacity:** 1. The sum of the weight of passengers and cargo that an aircraft can carry.<sup>251</sup>

**Passive:** In surveillance, an adjective applied to actions or equipments which emit no energy capable of being detected. (DOD)<sup>252</sup>

**Prepare:** A preliminary measure that serves to make ready for something.<sup>253</sup>

**Pre-position:** To place military units, equipment, or supplies at or near the point of planned use or at a designated location to reduce reaction time, and to ensure timely support of a specific force during initial phases of an operation.<sup>254</sup>

**Programs of Record (POR):** Acquisition program directed, funded effort that provides a new, improved, or continuing materiel, weapon, or information system or service capability in response to an approved need. Acquisition programs are divided into categories that are established to facilitate decentralized decision making, execution, and compliance with statutory requirements. (DOD 5000.1) See Acquisition Category (ACAT).<sup>255</sup>

**Prosecute:** The ability for assets to assess, search, detect, localize, track, and classify an underwater contact of interest.

**Radar Coverage:** The limits within which objects can be detected by one or more radar stations. (DOD)<sup>256</sup>

**Readiness State:** The ability of US military forces to fight and meet the demands of the national military strategy. Readiness is the synthesis of two distinct but interrelated levels. A. unit readiness—the ability to provide capabilities required by the combatant commanders to execute their assigned missions. This is derived from the ability of each unit to deliver the outputs for which it was designed. B. joint readiness—the combatant commander’s ability to integrate and synchronize ready combat and support forces to

---

<sup>251</sup> Ibid., p. 402.

<sup>252</sup> Ibid., p. 403.

<sup>253</sup> [www.dictionary.com](http://www.dictionary.com), (accessed 30 November 2005).

<sup>254</sup> Joint Chiefs of Staff, Department of Defense Dictionary of Military and Associated Terms, Joint Publication 1-02, (Washington, DC: 12 April 2001 (as amended through 31 August 2005)), p. 420.

<sup>255</sup> <http://deskbook.dau.mil/askaprof-akss/normal/qdetail2.asp?cgiSubjectAreaID=9&cgiQuestionID=15222>, (accessed 30 November 2005).

<sup>256</sup> Joint Chiefs of Staff, Department of Defense Dictionary of Military and Associated Terms, Joint Publication 1-02, (Washington, DC: 12 April 2001 (as amended through 31 August 2005)), p. 437.

execute his or her assigned missions. See also military capability; national military strategy.<sup>257</sup>

**Reconnaissance:** A mission undertaken to obtain, by visual observation or other detection methods, information about the activities and resources of an enemy or potential enemy, or to secure data concerning the meteorological, hydrographic, or geographic characteristics of a particular area. (DOD)<sup>258</sup>

**Reliability:** The probability that an item will perform a defined function in a defined environment without failure for a specified period of time.<sup>259</sup>

**Rules of Engagement:** Directives issued by competent military authority that delineate the circumstances and limitations under which United States forces will initiate and/or continue combat engagement with other forces encountered. Also called ROE. (DOD)<sup>260</sup>

**Search:** The systematic investigation of a particular area for the purpose of locating a submarine known or suspected to be in the area of interest. (DOD)<sup>261</sup>

**Secretary of Defense's 10-30-30:** The goal for closing forces to be within 10 days and defeating and sustaining an adversary within 30 days.<sup>262</sup>

**Self Deploying:** The ability for components of the System of System to become deployed when preset environmental or operational parameters are met without any human interface.

**Self Initiating:** The ability for component of the System of System to become operational when preset environmental or operational parameters are met without any human interface.

**Self Storing:** The ability for component of the System of System to place itself in a “safe” mode when a preset environmental or operational parameters are met without any human interface.

**Shoal:** A sandbank or bar that makes water shoal; i.e., a sand-bank that is not rocky and on which there is a water depth of 6 fathoms or less. (DOD)<sup>263</sup>

---

<sup>257</sup> Ibid., p. 444.

<sup>258</sup> Ibid., pp. 446-447.

<sup>259</sup> David Olwell and David Schrady, *OS 4580 logistics Systems Analysis Course Notes* (Naval Postgraduate School, Monterey, CA: 2005).

<sup>260</sup> Joint Chiefs of Staff, *Department of Defense Dictionary of Military and Associated Terms*, Joint Publication 1-02, (Washington, DC: 12 April 2001 (as amended through 31 August 2005)), p. 465.

<sup>261</sup> Ibid., p. 473.

<sup>262</sup> <http://www.defenselink.mil/news/Mar2005/d20050318nds2.pdf>, (accessed 30 November 2005).

**Signal-to-Noise Ratio:** The ratio of the amplitude of the desired signal to the amplitude of noise signals at a given point in time. (DOD)<sup>264</sup>

**Sonar:** A sonic device used primarily for the detection and location of underwater objects. (DOD)<sup>265</sup>

**Sonobuoy:** A sonar device used to detect submerged submarines that, when activated, relays information by radio. It may be active directional or nondirectional, or it may be passive directional or nondirectional. (DOD)<sup>266</sup>

**Sound Velocity Profile:** A plot of propagation speed (velocity) as a function of depth and it is the fundamental tool for predicting how sound will travel.

**Special Operations Forces:** Those Active and Reserve Component forces of the Military Services designated by the Secretary of Defense and specifically organized, trained, and equipped to conduct and support special operations. Also called SOF. (DOD)<sup>267</sup>

**Surveillance:** The systematic observation of aerospace, surface, or subsurface areas, places, by visual, aural, electronic, photographic, or other means. (DOD)<sup>268</sup>

**Survivability:** Concept which includes all aspects of protecting personnel, weapons, and supplies while simultaneously deceiving the enemy. Survivability tactics include building a good defense; employing frequent movement; using concealment, deception, and camouflage; and constructing fighting and protective positions for both individuals and equipment. (DOD)<sup>269</sup>

**Sustainment:** The provision of personnel, logistic, and other support required to maintain and prolong operations or combat until successful accomplishment or revision of the mission or of the national objective. (DOD)<sup>270</sup>

**Systems Engineering Design Process:** A methodology used by System Engineers to define the problem, generate alternatives, model and analyze alternatives, select the best alternative(s), implement that alternative and communicate the results.

---

<sup>263</sup> Joint Chiefs of Staff, Department of Defense Dictionary of Military and Associated Terms, Joint Publication 1-02, (Washington, DC: 12 April 2001 (as amended through 31 August 2005)), p. 485.

<sup>264</sup> Ibid., p. 489.

<sup>265</sup> Ibid., p. 491.

<sup>266</sup> Ibid., p. 491.

<sup>267</sup> Ibid p 496.

<sup>268</sup> Ibid p 518.

<sup>269</sup> Ibid p 519.

<sup>270</sup> Ibid p 519.

# Systems Engineering and Design Process

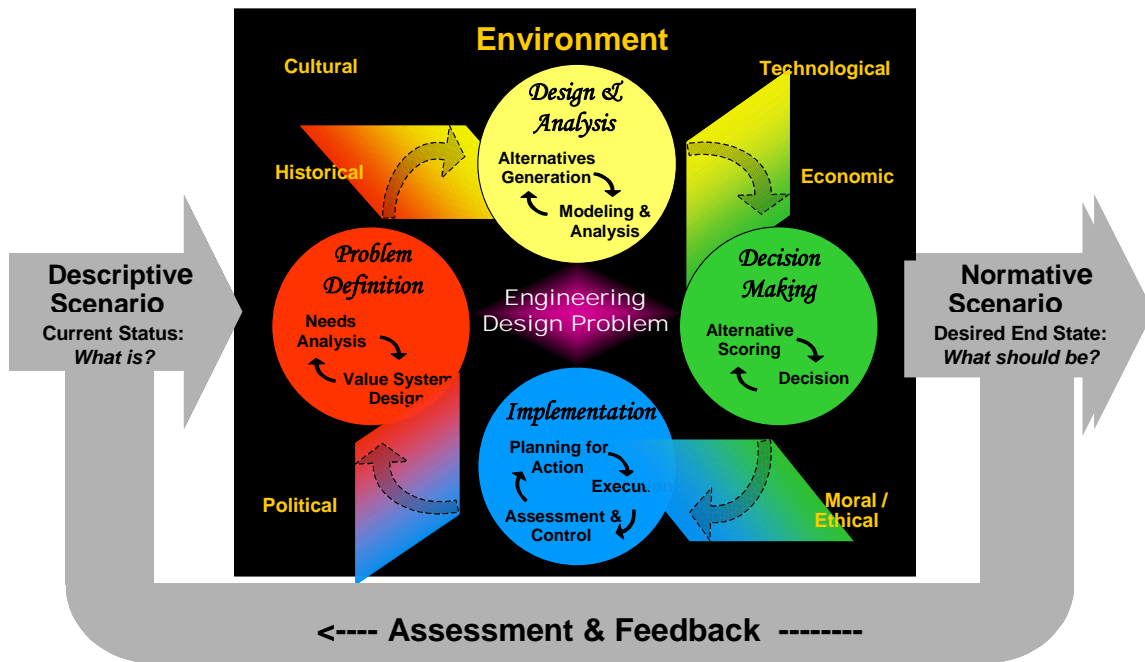


Figure 123: System Engineering and Design Process

**Tactical Control:** Command authority over assigned or attached forces or commands, or military capability or forces made available for tasking, that is limited to the detailed direction and control of movements or maneuvers within the operational area necessary to accomplish missions or tasks assigned. Tactical control is inherent in operational control. Tactical control may be delegated to, and exercised at any level at or below the level of combatant command. When forces are transferred between combatant commands, the command relationship the gaining commander will exercise (and the losing commander will relinquish) over these forces must be specified by the Secretary of Defense. Tactical control provides sufficient authority for controlling and directing the application of force or tactical use of combat support assets within the assigned mission or task. Also called TACON. (DOD)<sup>271</sup>

**Theater:** The geographical area for which a commander of a combatant command has been assigned responsibility. (DOD)<sup>272</sup>

<sup>271</sup> Ibid., p. 525.

<sup>272</sup> Ibid., p. 538.



**Theater of Operations:** A subarea within a theater of war defined by the geographic combatant commander required to conduct or support specific combat operations. Different theaters of operations within the same theater of war will normally be geographically separate and focused on different enemy forces. Theaters of operations are usually of significant size, allowing for operations over extended periods of time. Also called TO. (DOD)<sup>273</sup>

**Topography:** The configuration of the ground to include its relief and all features. Topography addresses both dry land and the sea floor (underwater topography). (DOD)<sup>274</sup>

**Transit Route:** A sea route which crosses open waters normally joining two coastal routes. (DOD)<sup>275</sup>

**Undersea Distance:** The maximum distance between a transmitter and receiver where a usable signal can be detected measured in feet or yards.<sup>276</sup>

- yds
- ft

**Undersea Warfare:** Operations conducted to establish battlespace dominance in the underwater environment, which permits friendly forces to accomplish the full range of potential missions and denies an opposing force the effective use of underwater systems and weapons. It includes offensive and defensive submarine, antisubmarine, and mine warfare operations. Also called USW. (DOD)<sup>277</sup>

**UUV Deployment Module (UDM):** The hypothetical UUV Deployment Module (UDM), consists of a payload bay, an aerodynamically shaped shell, a guidance control group, and a flight control group. The cargo bay would be designed to accept six small sea web components or one HWV class UUV. The shaped shell would provide for low drag, low observable carriage and glide performance at tactical airspeeds and the required lugs for carriage by the BRU-32 and Mk-38 launch rack. The outer casing is a clamshell design that would open at a specific position and altitude for delivery of the UUV.

---

<sup>273</sup> Ibid., p. 539.

<sup>274</sup> Ibid., p. 545.

<sup>275</sup> Ibid., p. 550.

<sup>276</sup> M.B. Porter, F.B. Jensen, and N.G. Pace, "High-Frequency Propagation for Acoustic Communications," *Impact of Littoral Environmental Variability on Acoustic Predictions and Sonar Performance*, (Kluwer Academic Publishers: 2002).

<sup>277</sup> Joint Chiefs of Staff, Department of Defense Dictionary of Military and Associated Terms, Joint Publication 1-02, (Washington, DC: 12 April 2001 (as amended through 31 August 2005)), p. 558.

**Vulnerability:** The susceptibility of a nation or military force to any action by any means through which its war potential or combat effectiveness may be reduced or its will to fight diminished. (DOD)<sup>278</sup>

---

<sup>278</sup> Ibid., p. 571.

## APPENDIX A: COMMAND EVALUATION MEASURES

**Data Rate:** The speed with which data can be transmitted from one device to another. Data rates are often measured in megabits (million bits) per second. These are usually abbreviated as Mbps or MBps, respectively.

- bps – bits per second
- kbps – Kilobits; 1,000 bits per second
- Mbps – Megabits; 1,000,000 bits per second
- Gbps – Gigabits; 1,000,000,000 bits per second

**Connection Time:** The time it takes to establish a connection between two nodes in a network measured in seconds.

**Network Establishment Speed:** The time it takes to establish the requisite number of nodes within a network for the network to be considered operational, measured in seconds or minutes.

**Access Time:** The time it takes to locate a single byte of information on a mass-storage device is called the access time, measured in seconds.

**Process Speed:** The time it takes for a node in the system to complete an assigned task, measured in milliseconds.

**Air/Surface Distance:** The maximum distance between a transmitter and a receiver, where usable signal can be detected measured in nautical miles.

- NM – Nautical Miles; 2,000 yards

**Undersea Distance:** The maximum distance between a transmitter and receiver, where a usable signal can be detected measured in feet or yards.

- yds - yards
- ft - feet

**Bit Error Rate:** The degree to which transmitted data truly reflects the intended content of the data when reconstructed following the transmission process, measured in percentage of bits transmitted with errors.

- BER – Bit Error Rate

## APPENDIX B: MODELING ANALYSIS SUPPORTING GRAPHS

### B.1 SEARCH AND DETECTION

#### B.1.1 Pd of Red Submarines by Blue Assets

The following four graphs (Figures 124 through 127) illustrate, by alternative, the probability of detection of any or all Red assets by Blue assets per time step. The thin lines represent the detection of each of 8 Red submarines in the scenario—6 submarines that were in-port at scenario start and 2 submarines that were underway for the entire scenario. The mean detection line is represented by the thick black line in each graph and shows the probability of detecting any of the 8 submarines at the specific scenario hour. The detection total (probability of detecting all 8 submarines by each time step) is shown by the thick blue line in each graph.

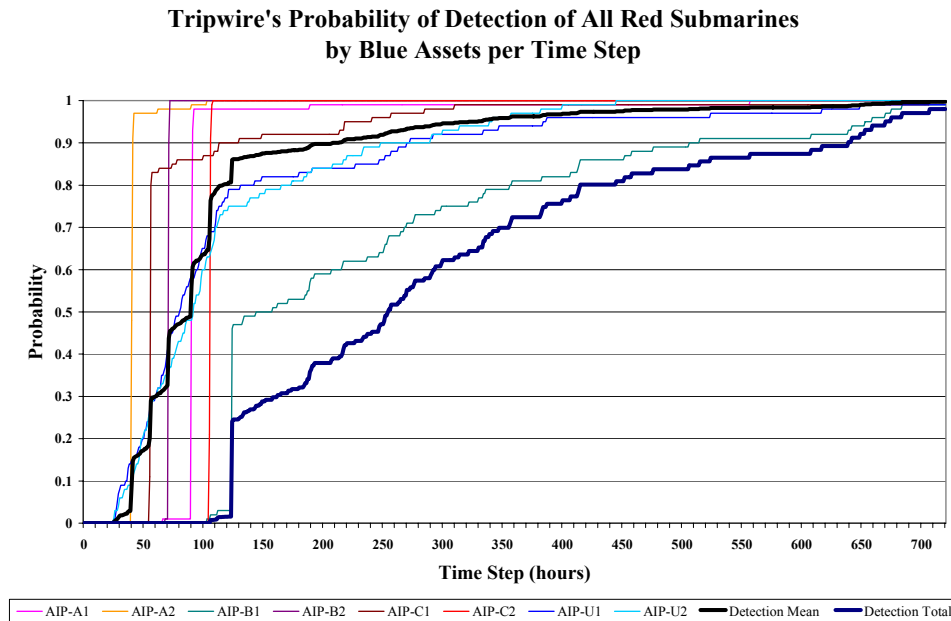
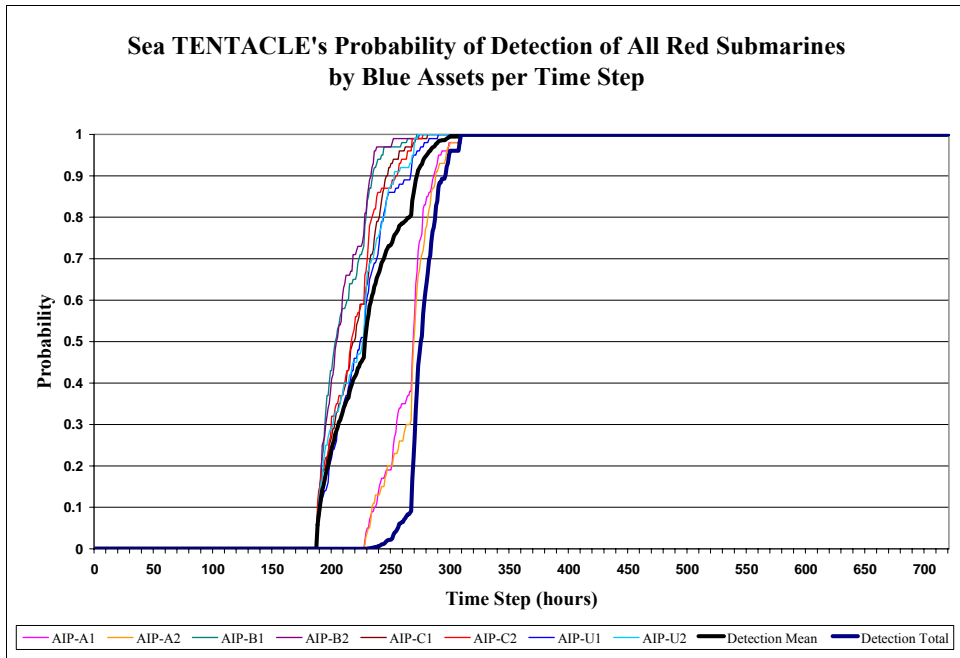
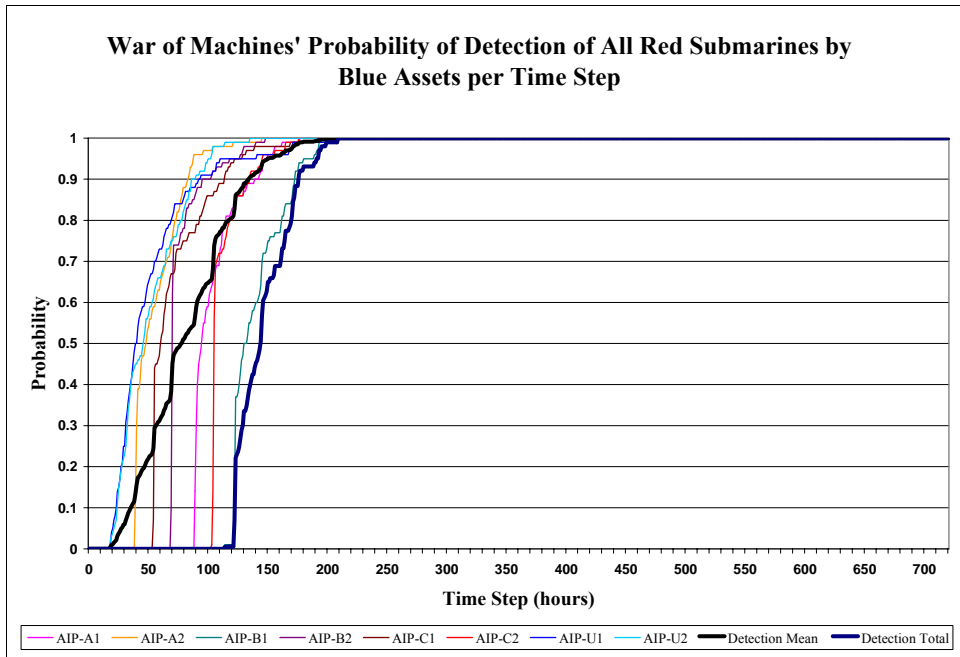


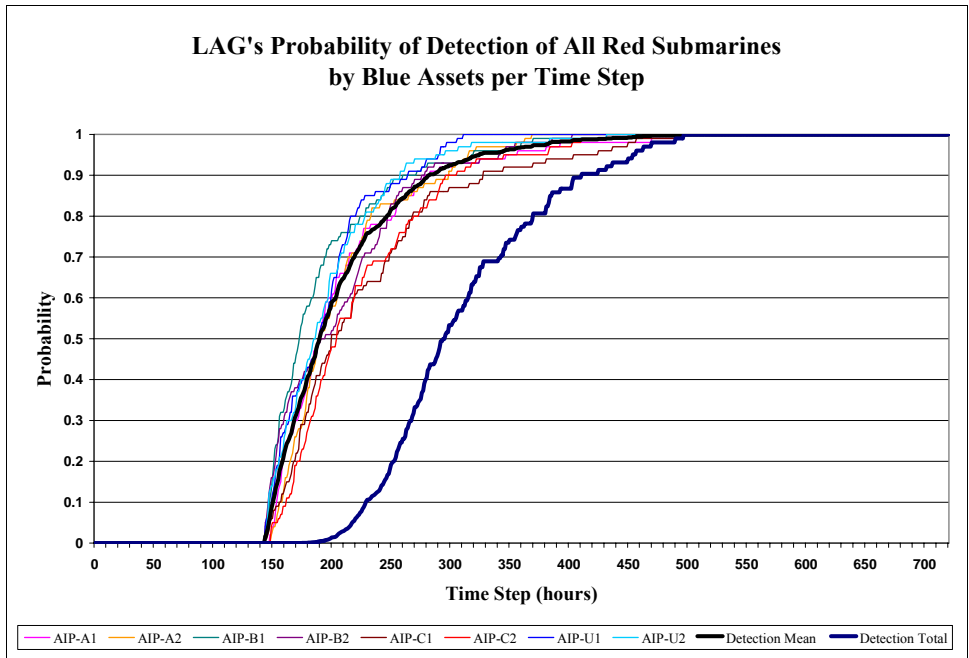
Figure 124: Tripwire, Probability of Detection of All Red Submarines by Blue Assets per Time Step



**Figure 125: TSSE, Probability of Detection of All Red Submarines by Blue Assets per Time Step**



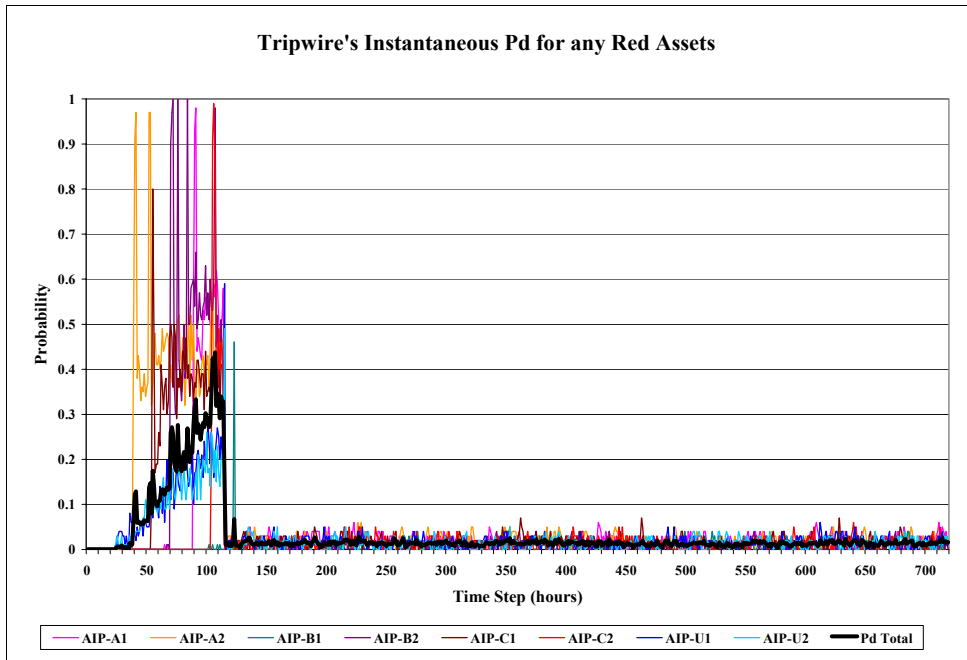
**Figure 126: War of Machines, Probability of Detection of All Red Submarines by Blue Assets per Time Step**



**Figure 127: LAG, Probability of Detection of All Red Submarines by Blue Assets per Time Step**

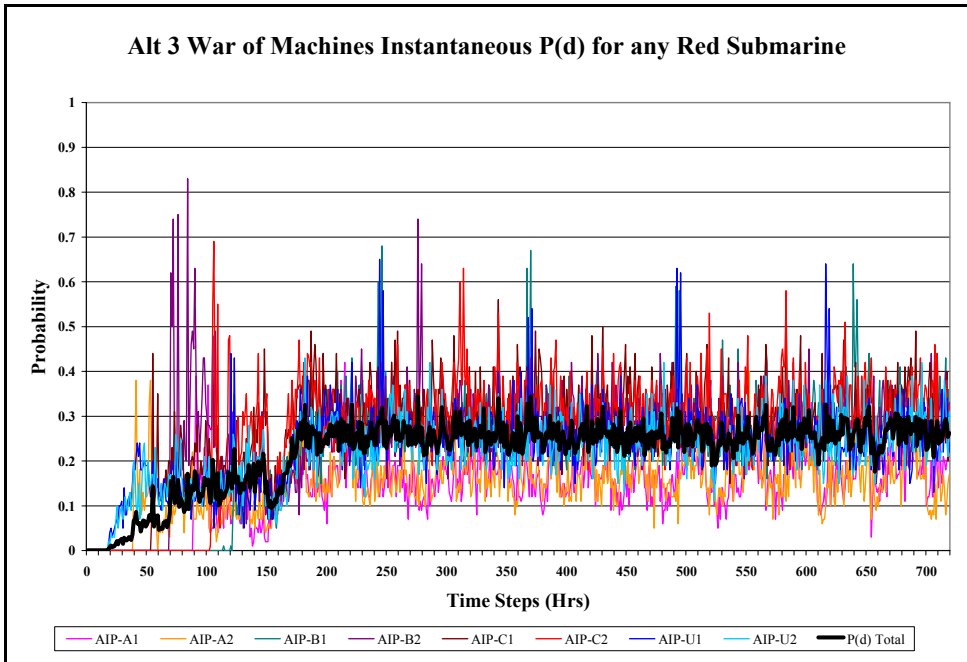
### **B.1.2 Instantaneous Pd for any Red Submarines by Blue Assets**

The following four graphs (Figures 128 through 131) illustrate, by alternative, the instantaneous probability of detection of Red assets by Blue assets per time step. As in Figures 124 through 127, the thin lines represent the detection of each of 8 Red submarines in the scenario—6 submarines that were in-port at scenario start and 2 submarines that were underway for the entire scenario. The data represents each alternative’s instantaneous ability to detect a submarine at that given time step that is based on all detections throughout all of the iterations of the scenario.

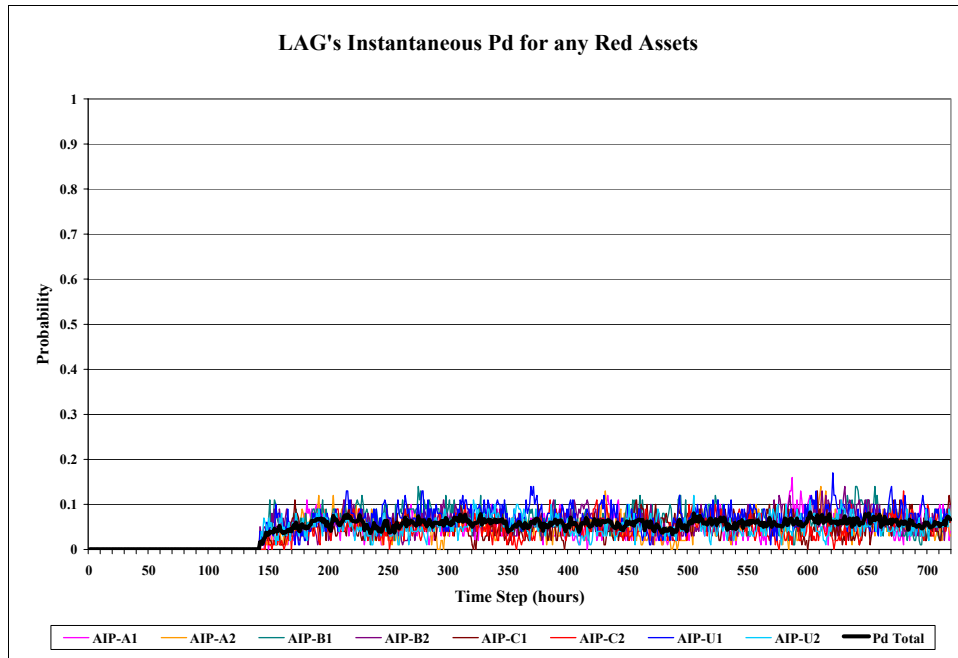


**Figure 128: Tripwire Alternative Pd Representing Instantaneous Average Probability of Blue Detecting any Red Submarine at the Given Time Steps**

**Figure 129: Sea TENTACLE Alternative Pd Representing Instantaneous Average Probability of Blue Detecting any Red Submarine at the Given Time Steps**



**Figure 130: War of Machines Alternative Pd Representing Instantaneous Average Probability of Blue Detecting any Red Submarine at the Given Time Steps**



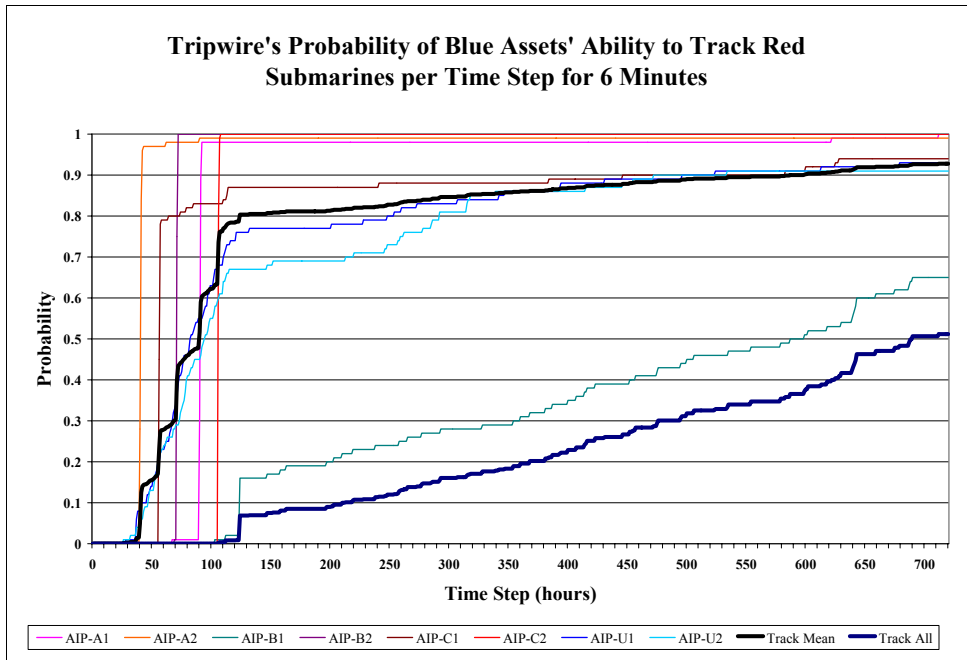
**Figure 131: LAG Alternative Pd Representing Instantaneous Average Probability of Blue Detecting any Red Submarine at the Given Time Steps**

## B.2 TRACKING

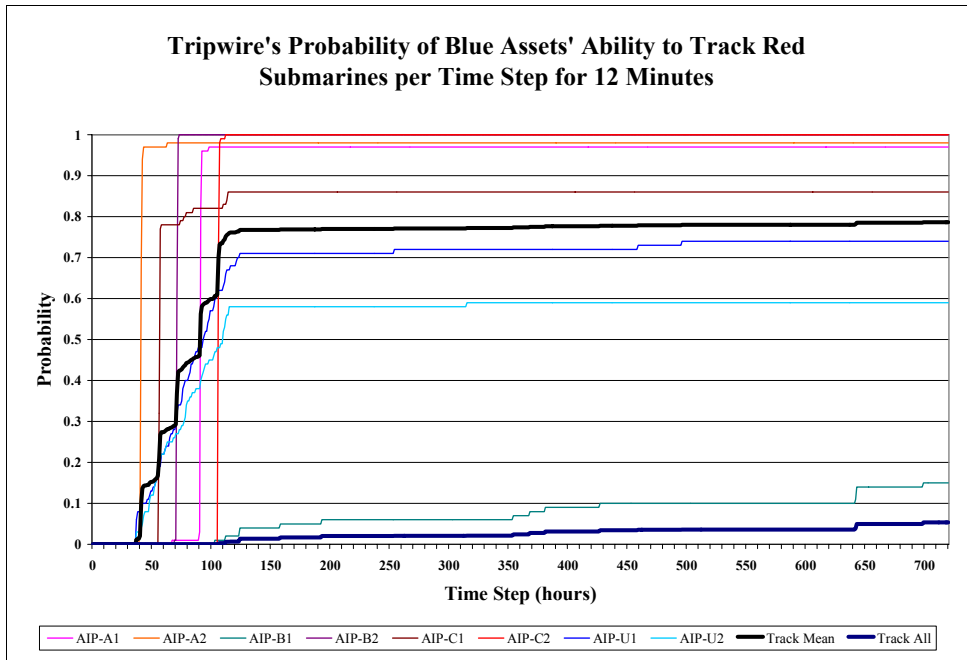
### B.2.1 Tripwire Alternative

Figures 132 through 140 represent the probability that Blue assets can track Red submarines continuously for the amount of time shown on each graph, ranging from 6 minutes to 54 minutes in 6-minute time intervals for the Tripwire Alternative. Each thin line represents the probability of Blue assets being able to track that particular Red submarine for that specific time period. The solid black line is the mean tracking ability of any Red submarine, while the solid blue line represents Blue's ability to track all 8 of Red's submarines for that specified period of time.

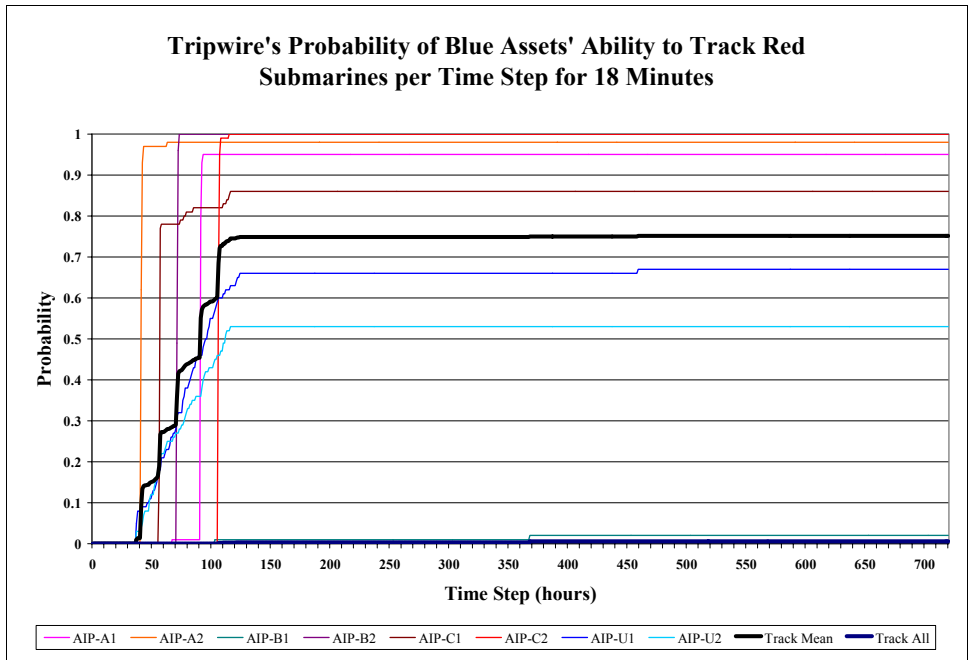




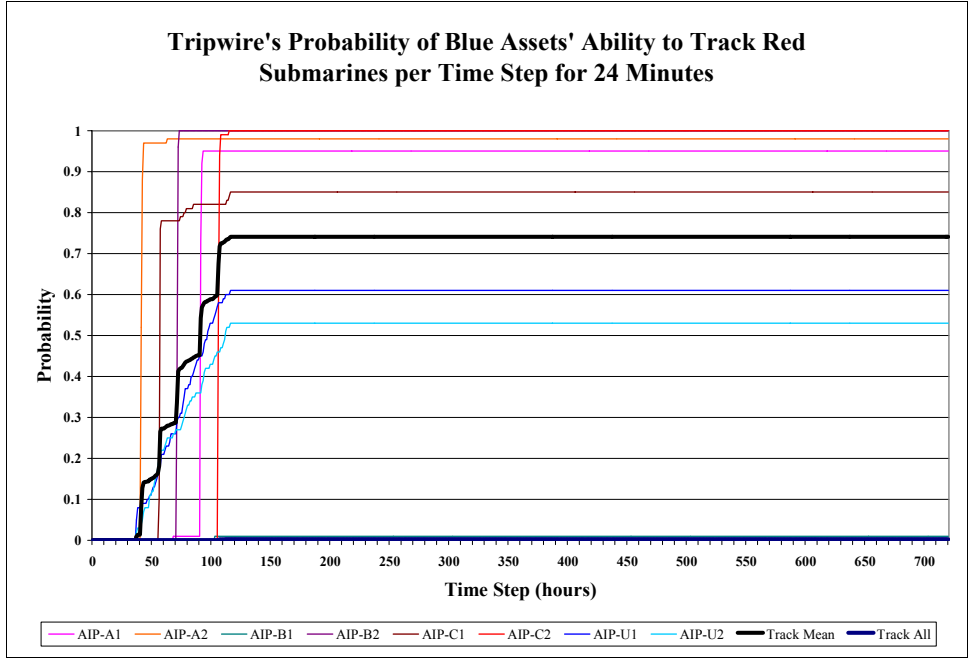
**Figure 132: Probability that Blue Assets can Successfully Track Red Submarines per Time Step in 6 Minutes for Tripwire Alternative**



**Figure 133: Probability that Blue Assets can Successfully Track Red Submarines per Time Step in 12 Minutes for Tripwire Alternative**



**Figure 134: Probability that Blue Assets can Successfully Track Red Submarines per Time Step in 18 Minutes for Tripwire Alternative**



**Figure 135: Probability that Blue Assets can Successfully Track Red Submarines per Time Step in 24 Minutes for Tripwire Alternative**

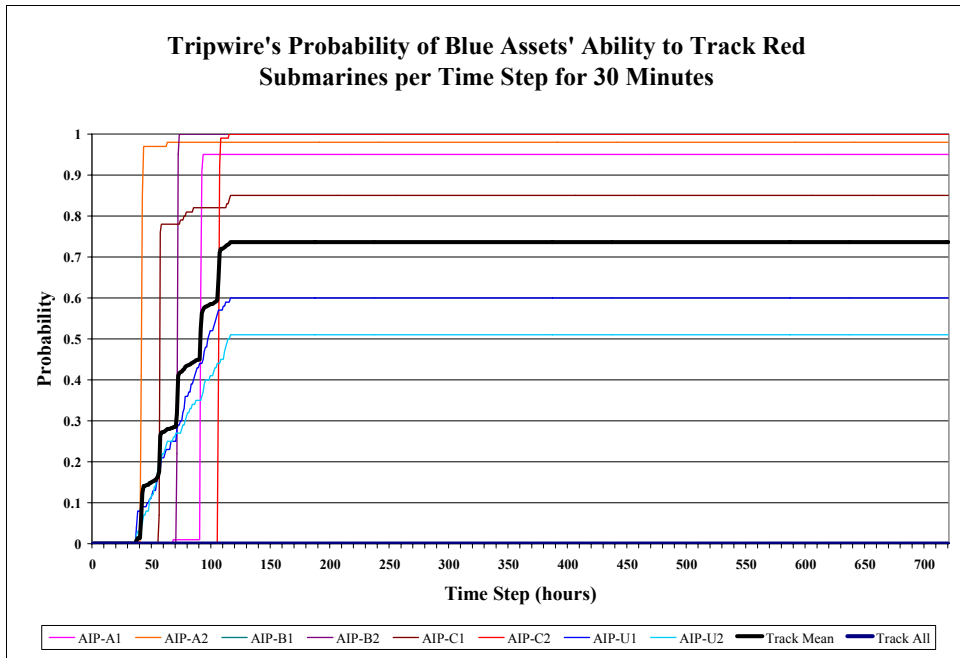


Figure 136: Probability that Blue Assets can Successfully Track Red Submarines per Time Step in 30 Minutes for Tripwire Alternative

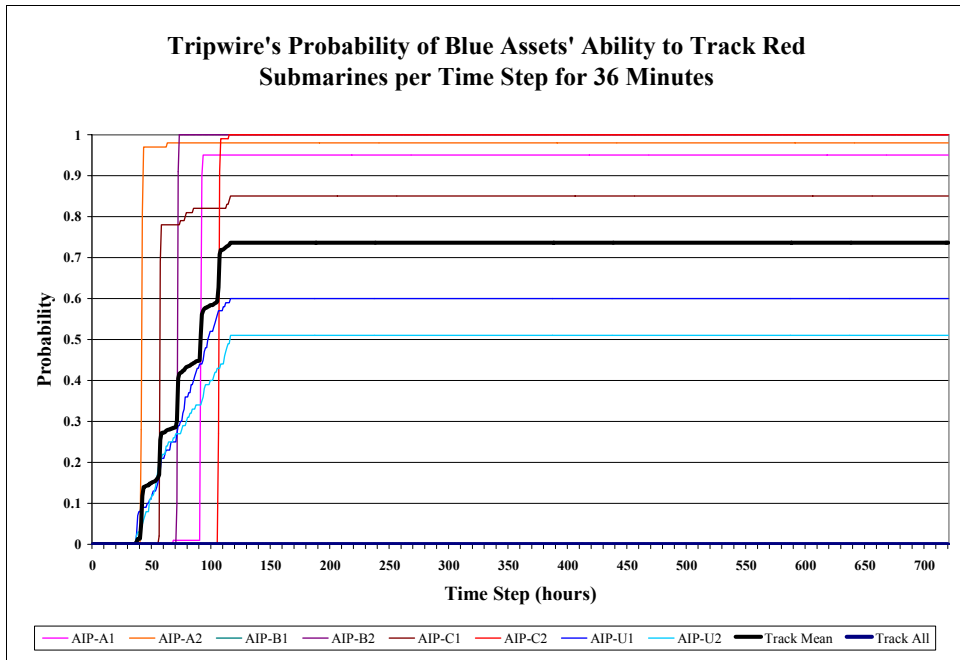
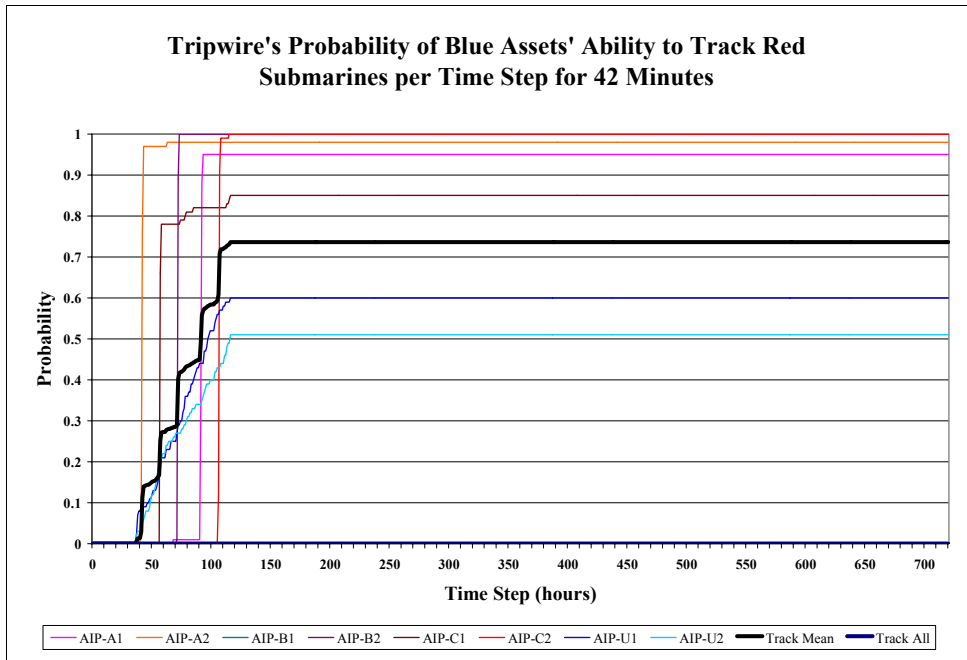
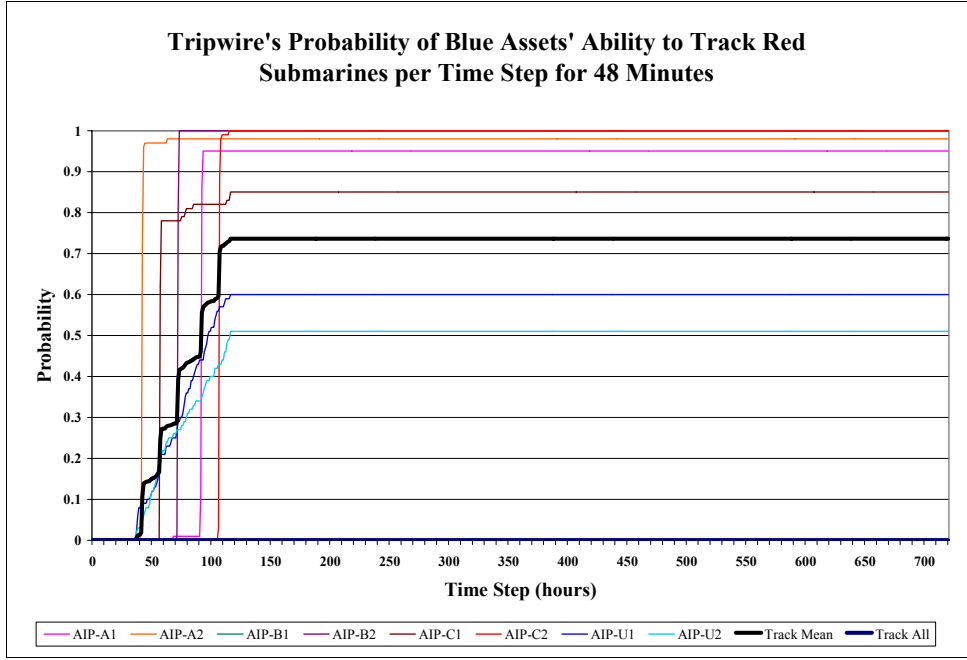


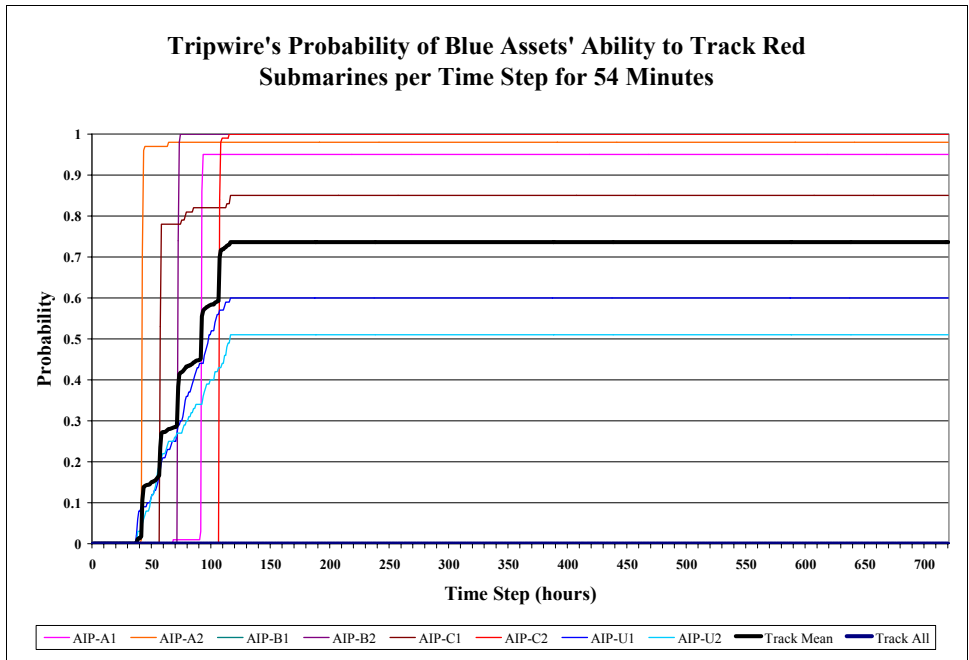
Figure 137: Probability that Blue Assets can Successfully Track Red Submarines per Time Step in 36 Minutes for Tripwire Alternative



**Figure 138: Probability that Blue Assets can Successfully Track Red Submarines per Time Step in 42 Minutes for Tripwire Alternative**



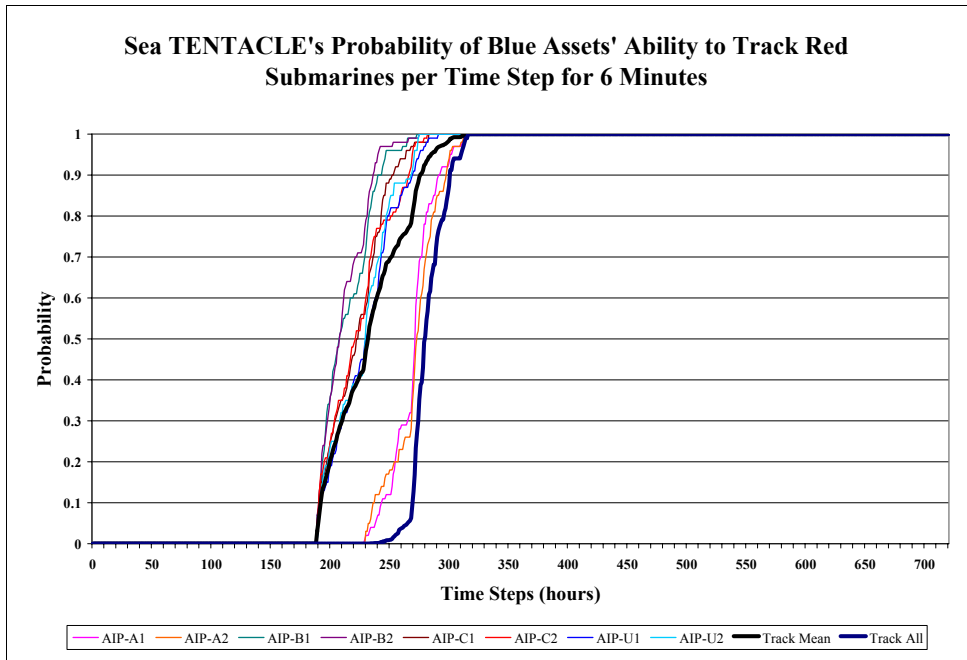
**Figure 139: Probability that Blue Assets can Successfully Track Red Submarines per Time Step in 48 Minutes for Tripwire Alternative**



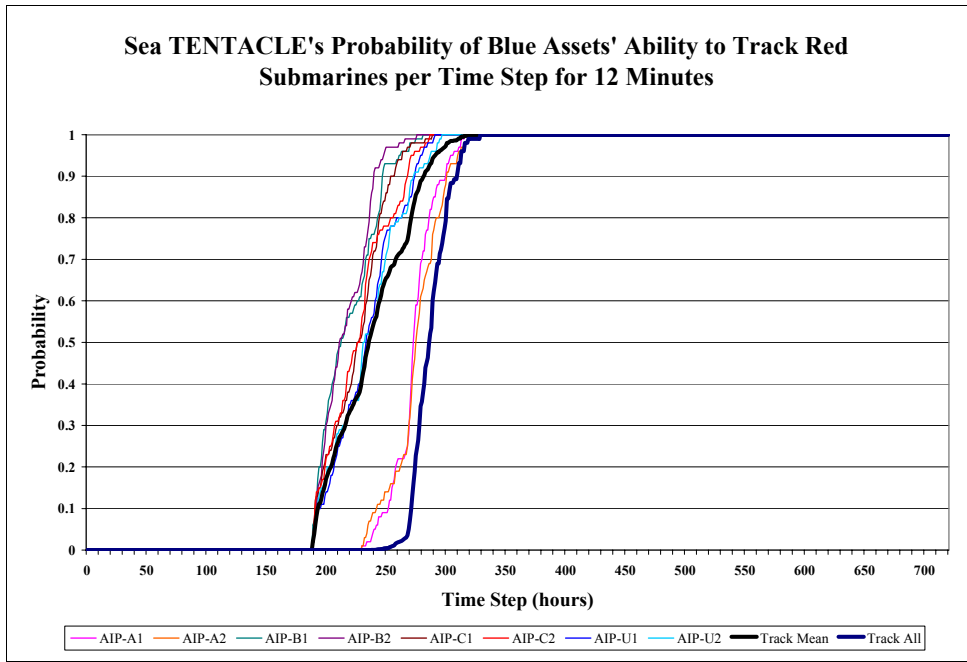
**Figure 140: Probability that Blue Assets can Successfully Track Red Submarines per Time Step in 54 Minutes for Tripwire Alternative**

### B.2.2 TSSE Alternative

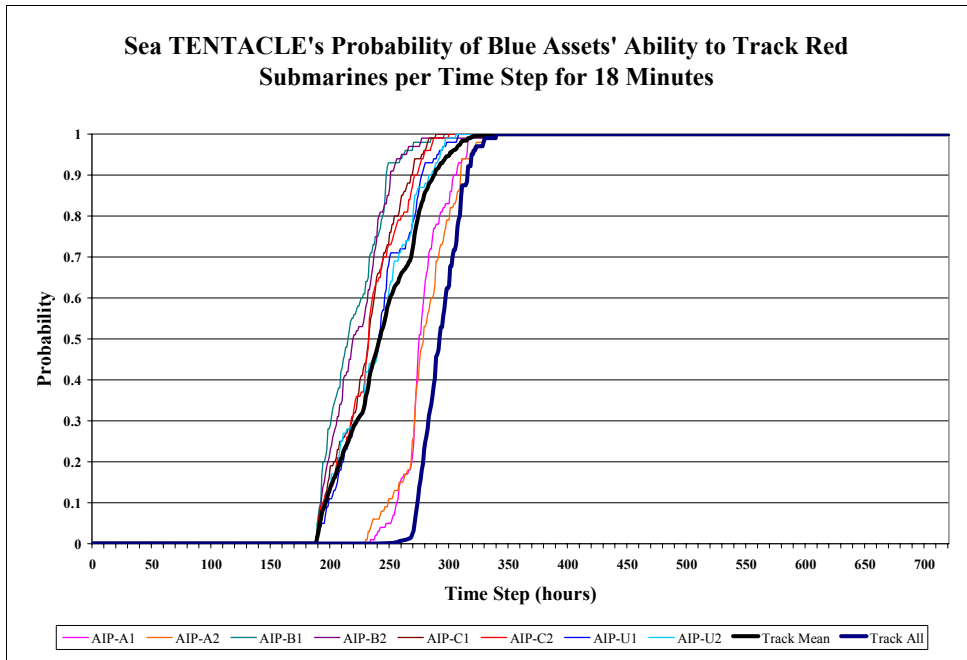
Figures 141 through 149 represent the probability that Blue assets can track Red submarines continuously for the amount of time shown on each graph, ranging from 6 minutes to 54 minutes in 6-minute time intervals for the TSSE alternative. Each thin line represents the probability of Blue assets being able to track that particular Red submarine for that specific time period. The solid black line is the mean tracking ability of any Red submarine, while the solid blue line represents Blue's ability to track all 8 of Red's submarines for that specified period of time.



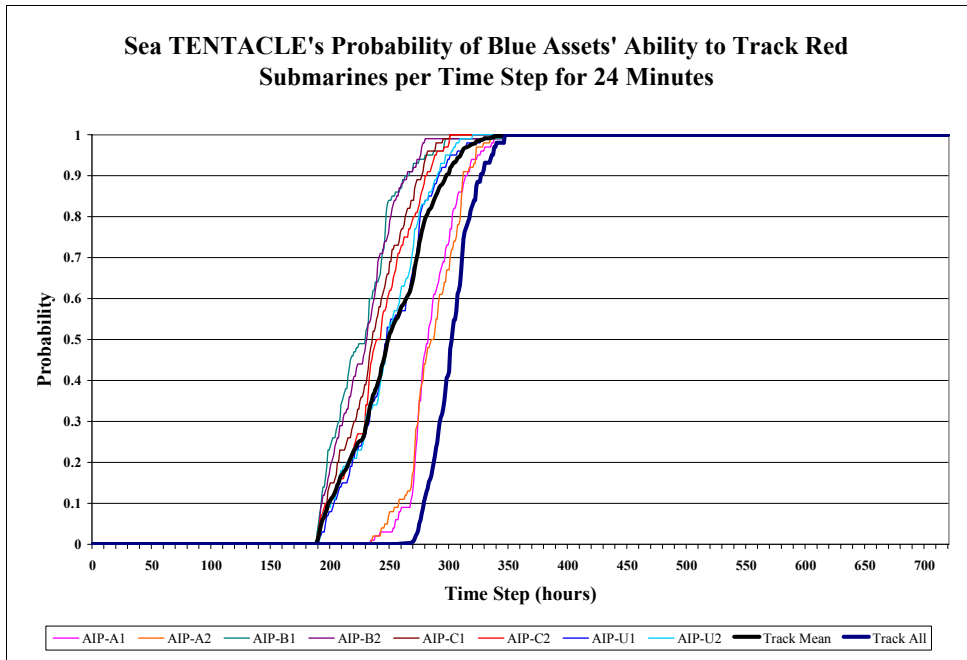
**Figure 141: Probability that Blue Assets can Successfully Track Red Submarines per Time Step in 6 Minutes for Sea TENTACLE Alternative**



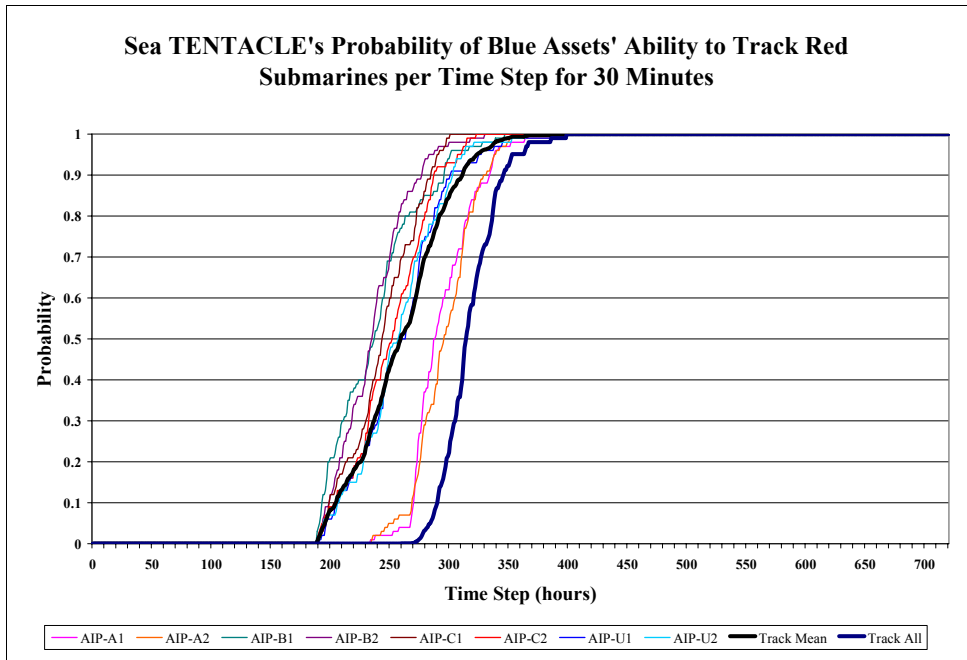
**Figure 142: Probability that Blue Assets can Successfully Track Red Submarines per Time Step in 12 Minutes for Sea TENTACLE Alternative**



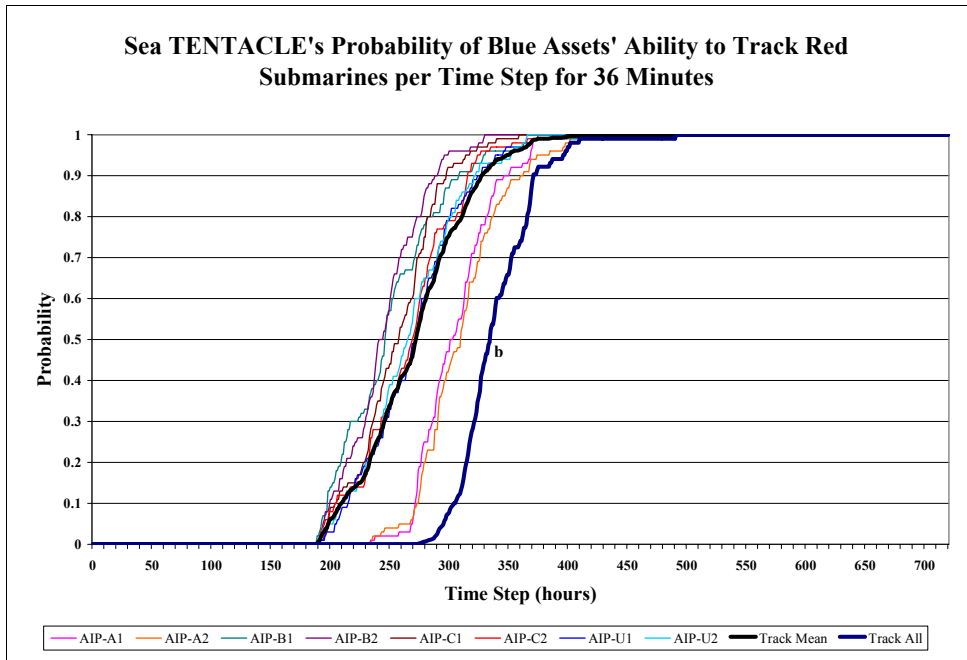
**Figure 143: Probability that Blue Assets can Successfully Track Red Submarines per Time Step in 18 Minutes for Sea TENTACLE Alternative**



**Figure 144: Probability that Blue Assets can Successfully Track Red Submarines per Time Step in 24 Minutes for Sea TENTACLE Alternative**

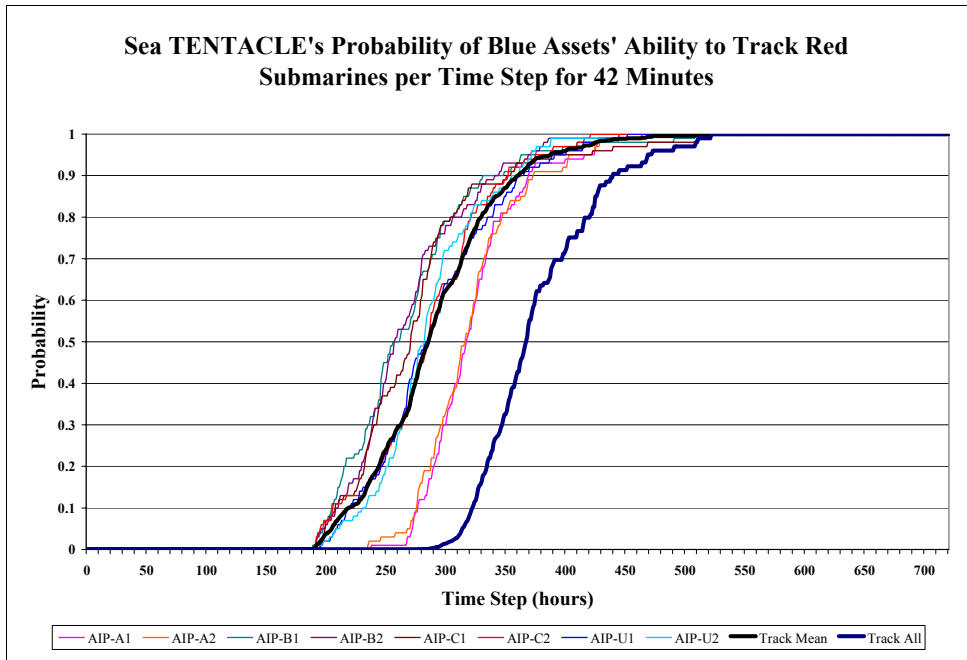


**Figure 145: Probability that Blue Assets can Successfully Track Red Submarines per Time Step in 30 Minutes for Sea TENTACLE Alternative**

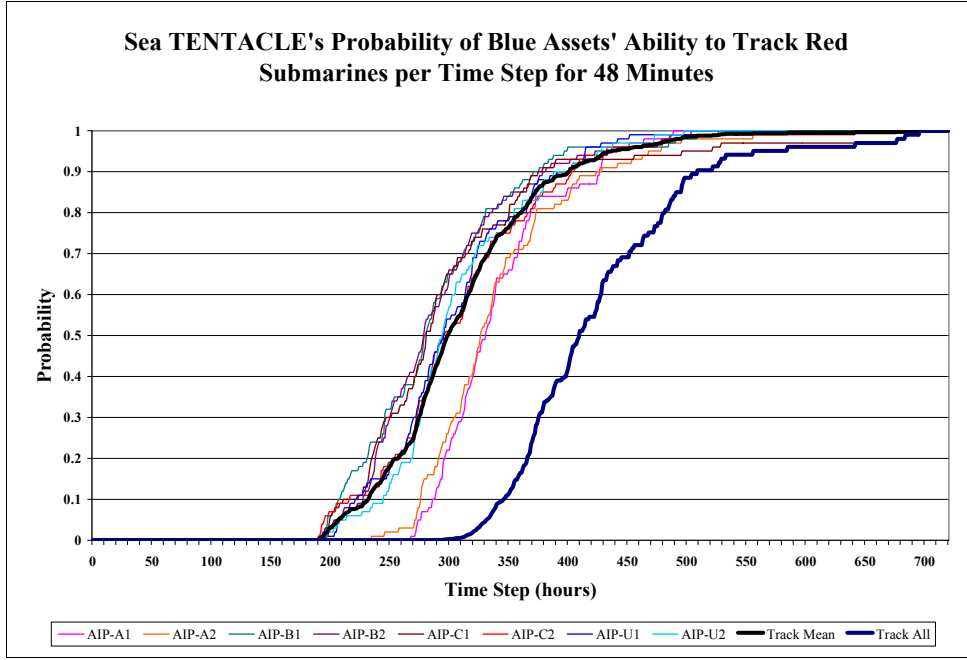


**Figure 146: Probability that Blue Assets can Successfully Track Red Submarines per Time Step in 36 Minutes for Sea TENTACLE Alternative**

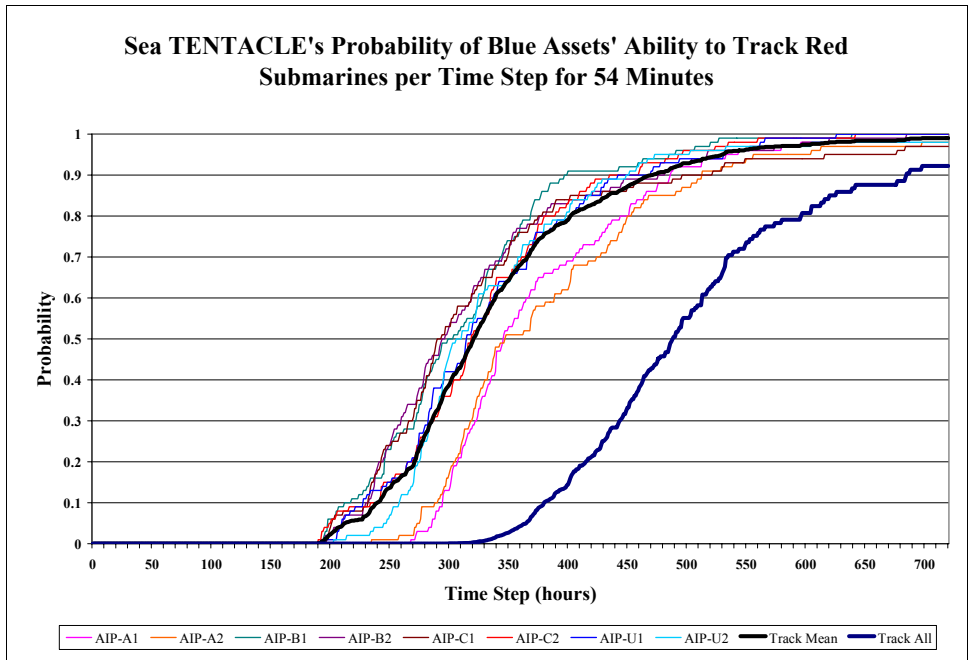




**Figure 147: Probability that Blue Assets can Successfully Track Red Submarines per Time Step in 42 Minutes for Sea TENTACLE Alternative**



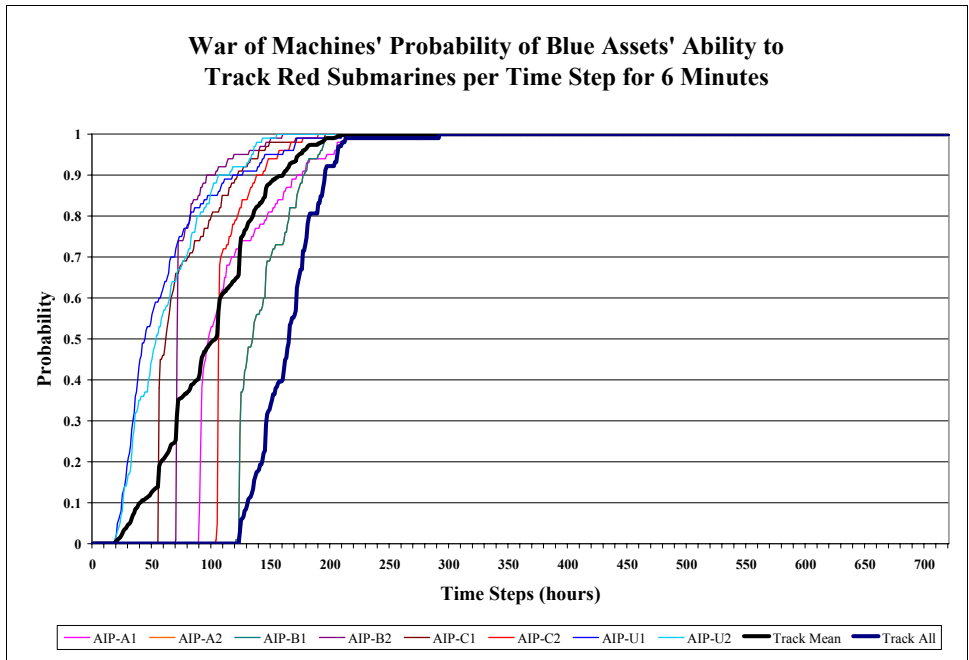
**Figure 148: Probability that Blue Assets can Successfully Track Red Submarines per Time Step in 48 Minutes for Sea TENTACLE Alternative**



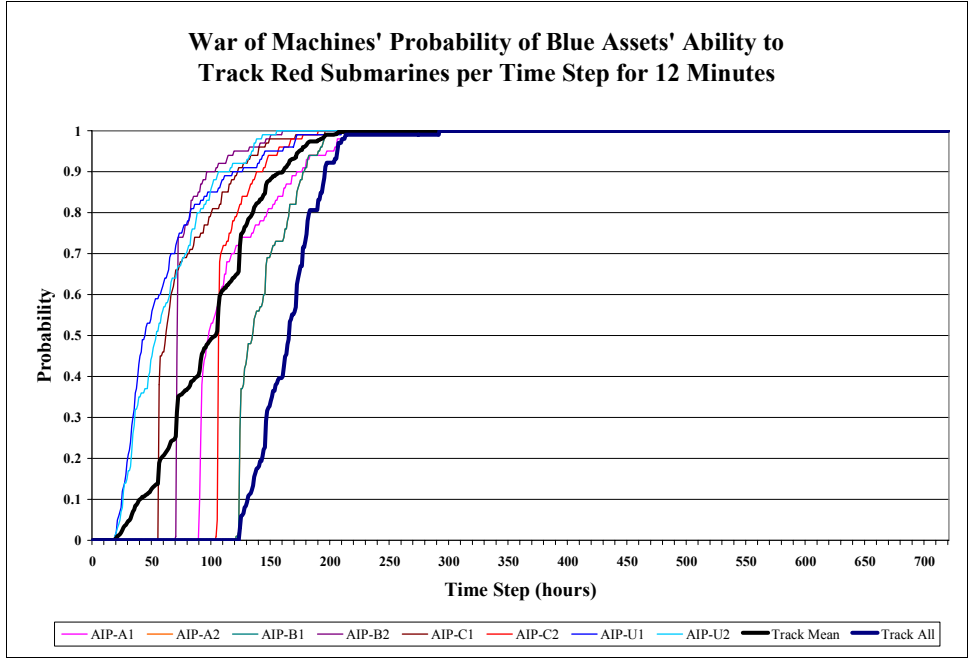
**Figure 149: Probability that Blue Assets can Successfully Track Red Submarines per Time Step in 54 Minutes for Sea TENTACLE Alternative**

### B.2.3 War of Machines Alternative

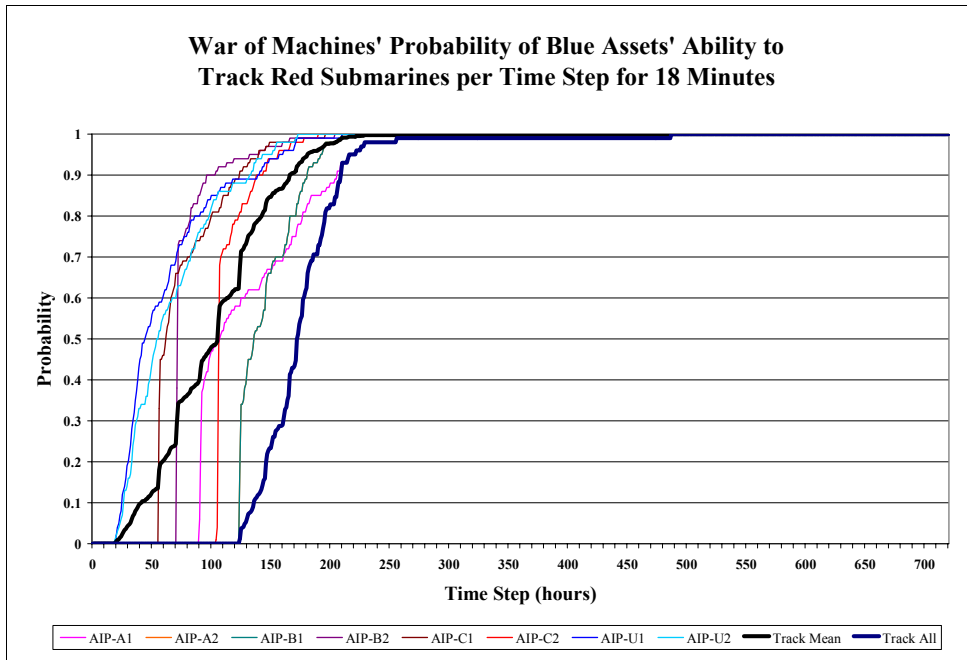
Figures 150 through 158 represent the probability that Blue assets can track Red submarines continuously for the amount of time shown on each graph, ranging from 6 minutes to 54 minutes in 6-minute time intervals for the War of Machines alternative. Each thin line represents the probability of Blue assets being able to track that particular Red submarine for that specific time period. The solid black line is the mean tracking ability of any Red submarine, while the solid blue line represents Blue's ability to track all 8 of Red's submarines for that specified period of time.



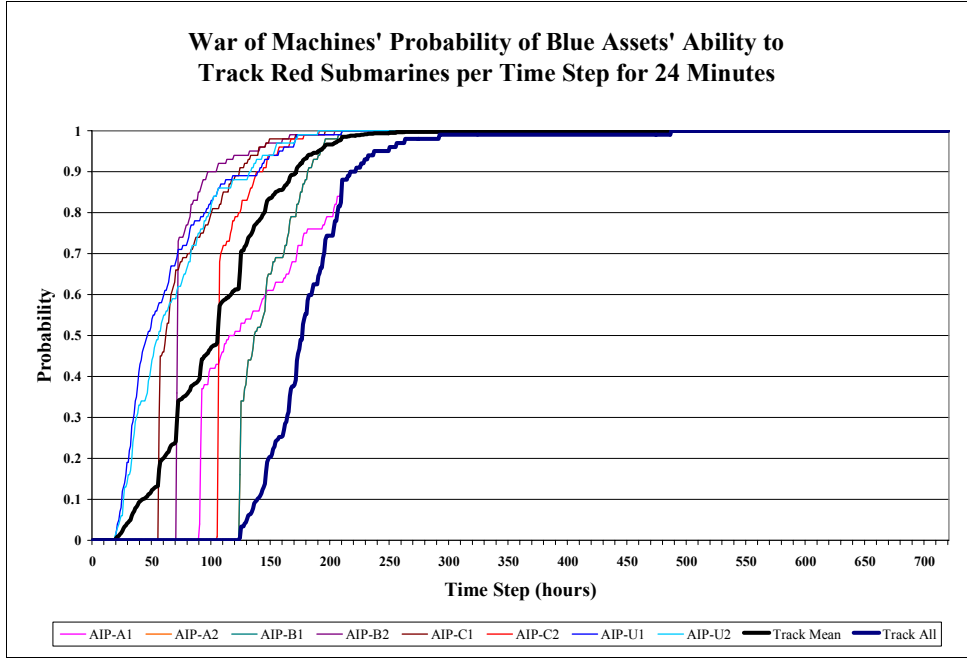
**Figure 150: Probability that Blue Assets can Successfully Track Red Submarines per Time Step in 6 Minutes for War of Machines Alternative**



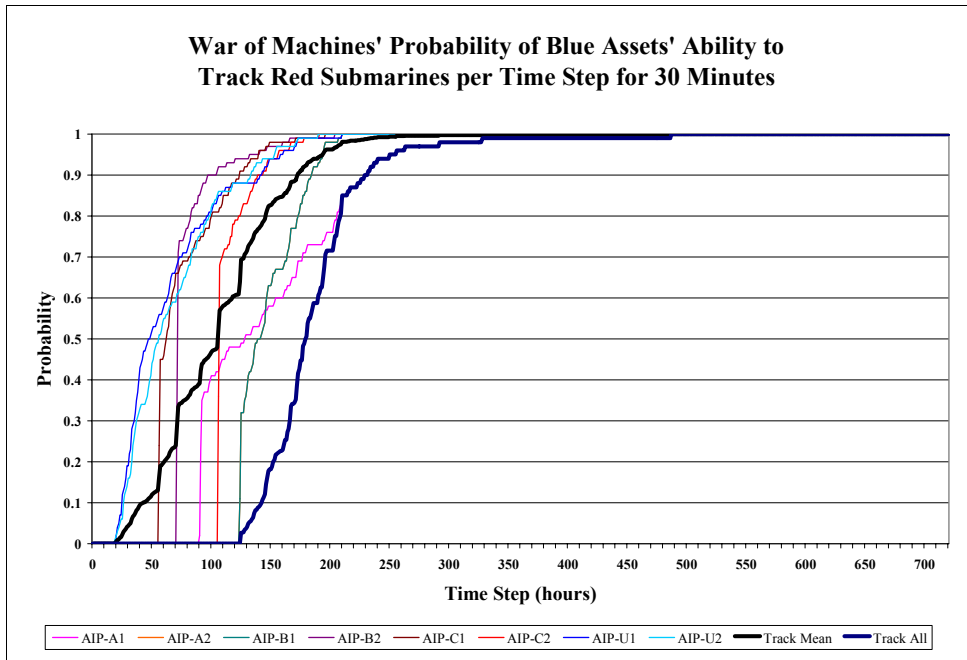
**Figure 151: Probability that Blue Assets can Successfully Track Red Submarines per Time Step in 12 Minutes for War of Machines Alternative**



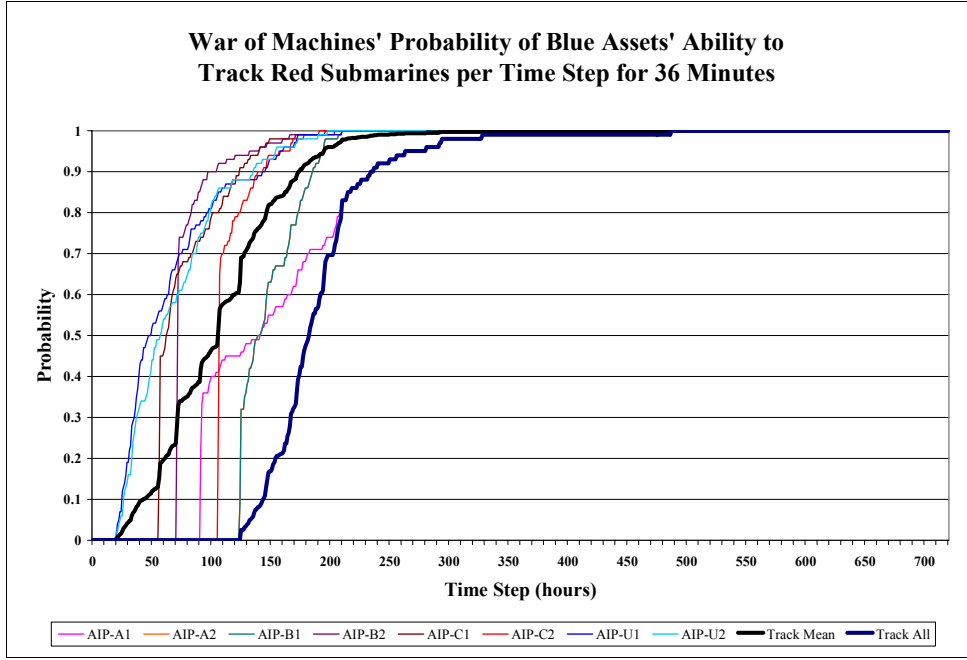
**Figure 152: Probability that Blue Assets can Successfully Track Red Submarines per Time Step in 18 Minutes for War of Machines Alternative**



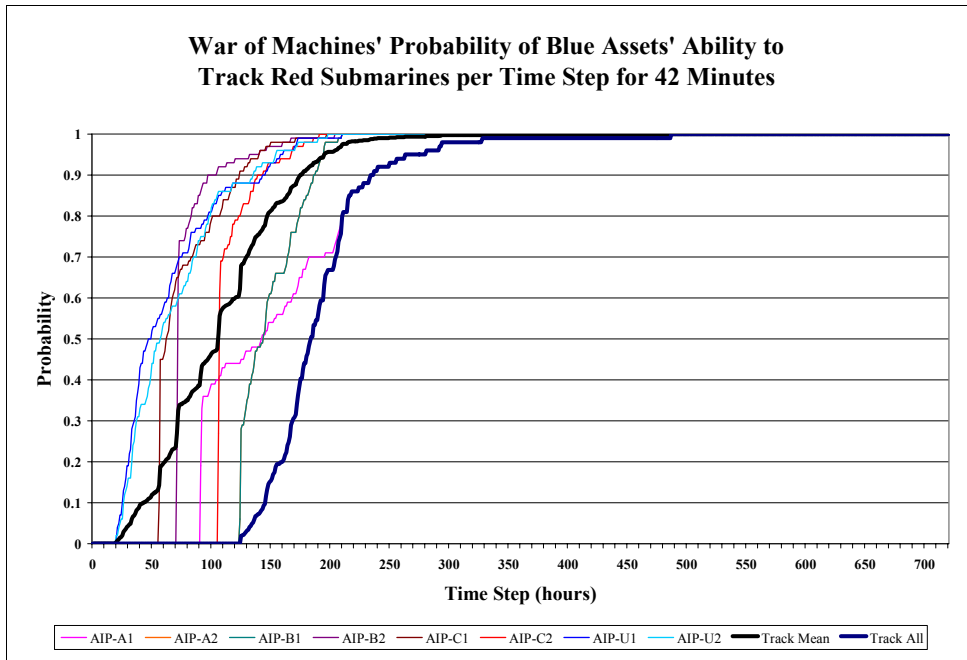
**Figure 153: Probability that Blue Assets can Successfully Track Red Submarines per Time Step in 24 Minutes for War of Machines Alternative**



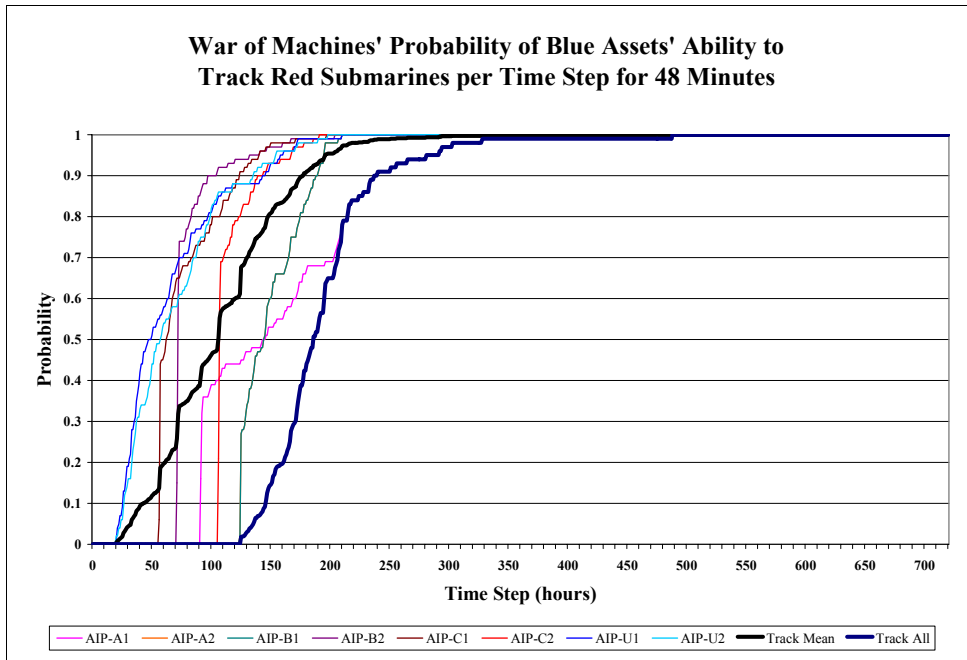
**Figure 154: Probability that Blue Assets can Successfully Track Red Submarines per Time Step in 30 Minutes for War of Machines Alternative**



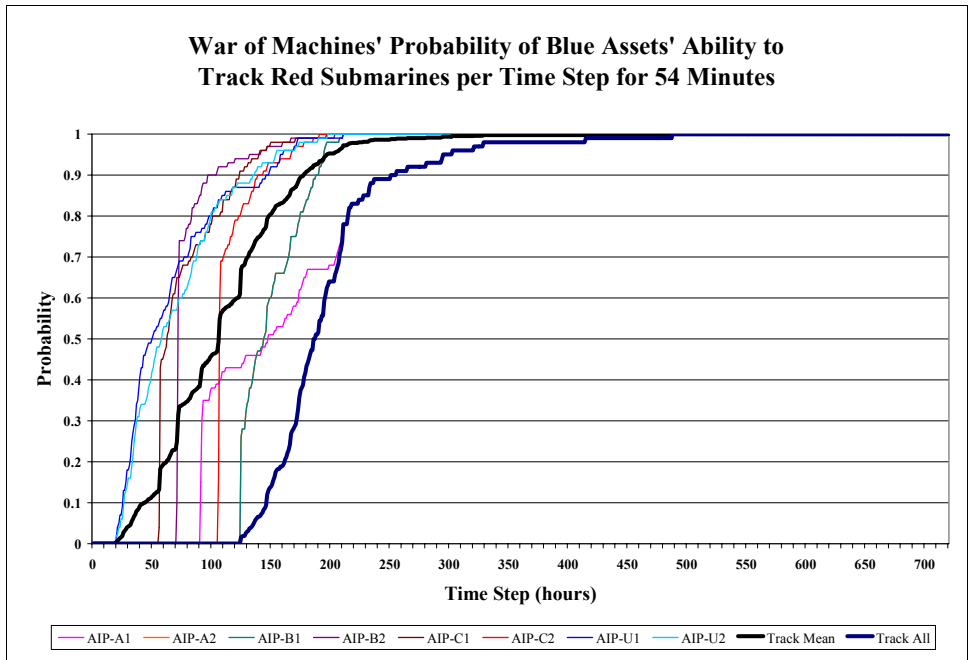
**Figure 155: Probability that Blue Assets can Successfully Track Red Submarines per Time Step in 36 Minutes for War of Machines Alternative**



**Figure 156: Probability that Blue Assets can Successfully Track Red Submarines per Time Step in 42 Minutes for War of Machines Alternative**



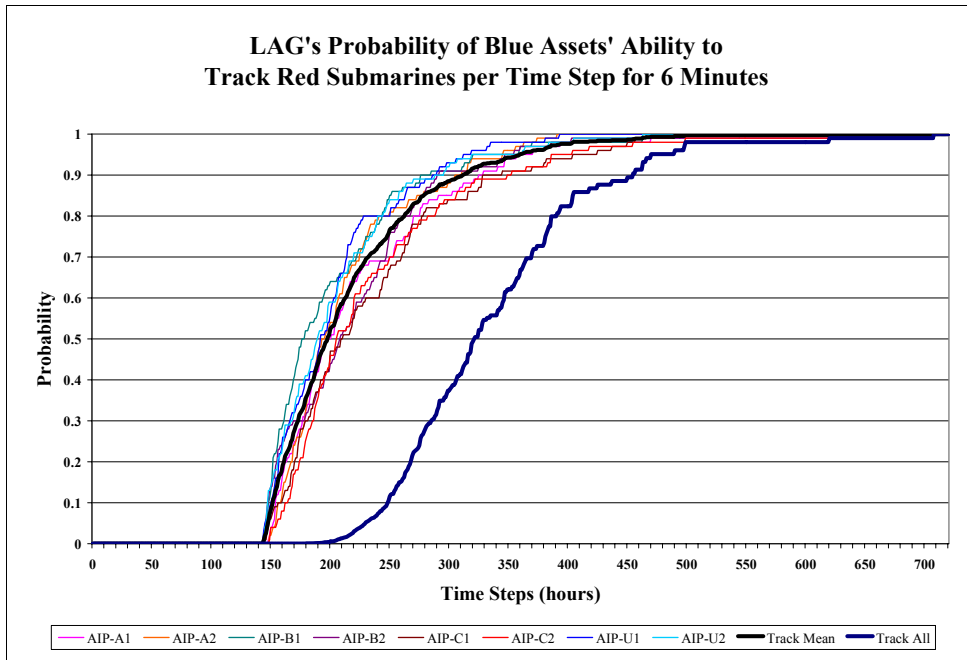
**Figure 157: Probability that Blue Assets can Successfully Track Red Submarines per Time Step in 48 Minutes for War of Machines Alternative**



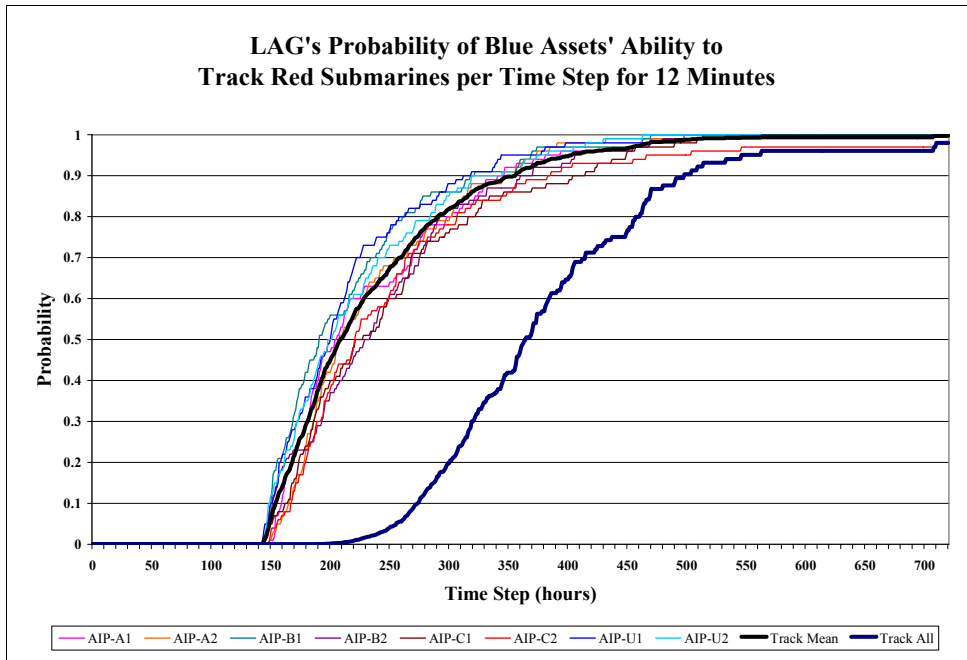
**Figure 158: Probability that Blue Assets can Successfully Track Red Submarines per Time Step in 54 Minutes for War of Machines Alternative**

### B.2.4 LAG Alternative

Figures 159 through 167 represent the probability that Blue assets can track Red submarines continuously for the amount of time shown on each graph, ranging from 6 minutes to 54 minutes in 6-minute time intervals for the LAG Alternative. Each thin line represents the probability of Blue assets being able to track that particular Red submarine for that specific time period. The solid black line is the mean tracking ability of any Red submarine, while the solid blue line represents Blue’s ability to track all 8 of Red’s submarines for that specified period of time.

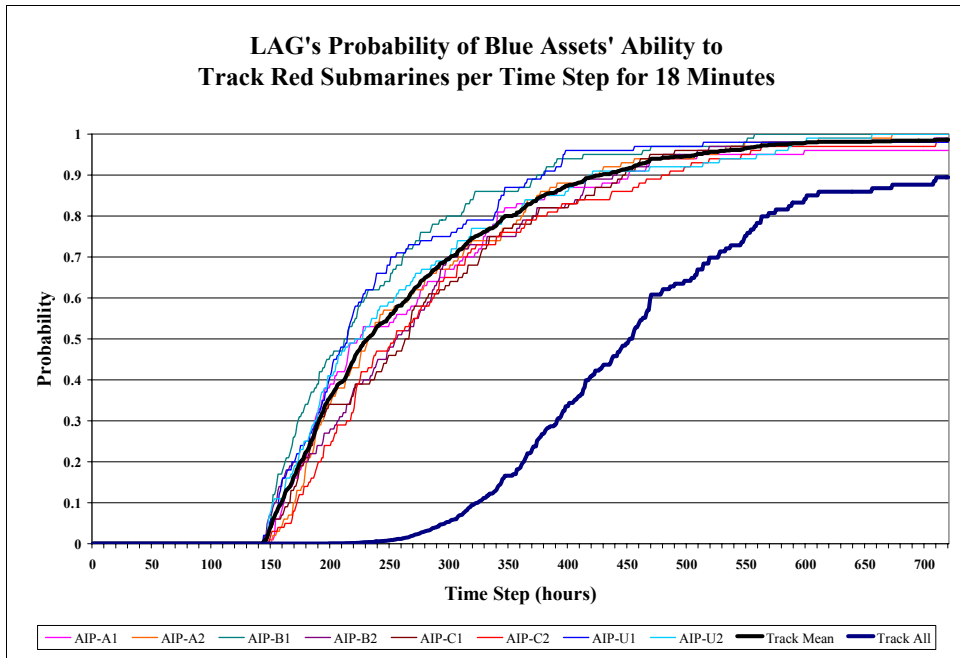


**Figure 159: Probability that Blue Assets can Successfully Track Red Submarines per Time Step in 6 Minutes for LAG Alternative**

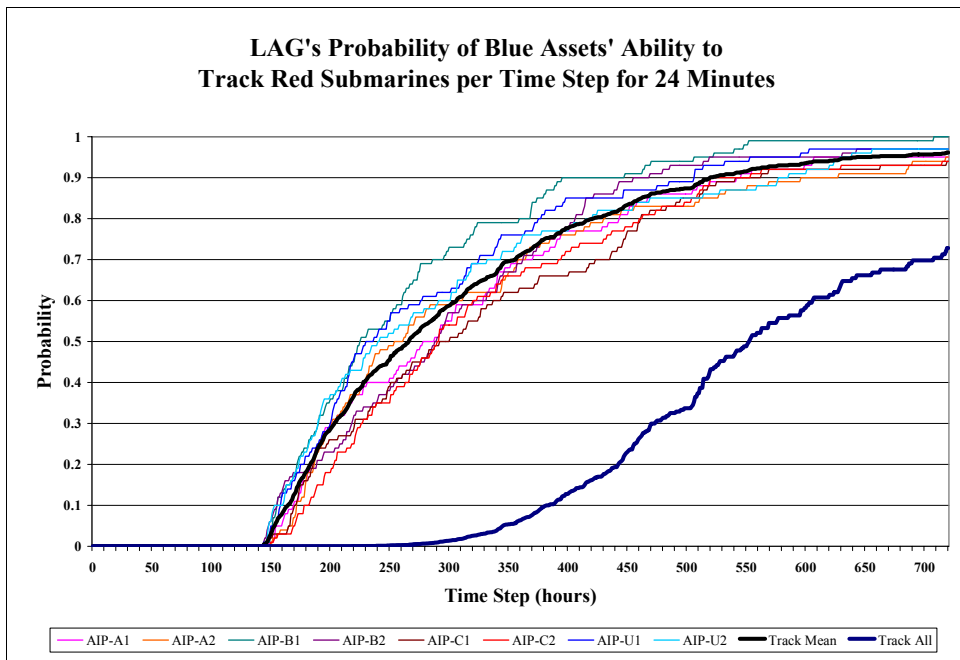


**Figure 160: Probability that Blue Assets can Successfully Track Red Submarines per Time Step in 12 Minutes for LAG Alternative**

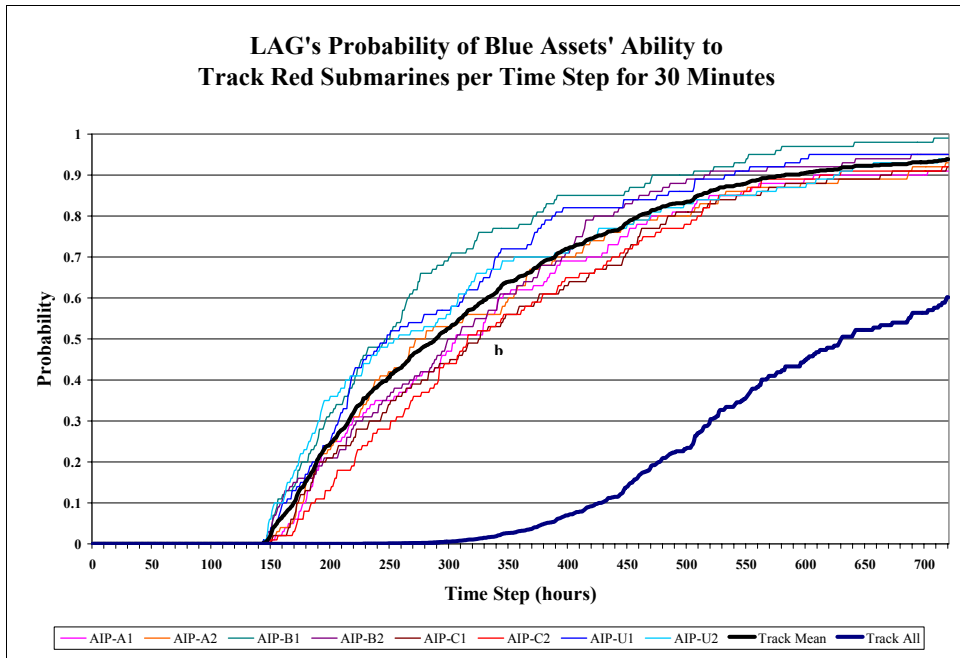




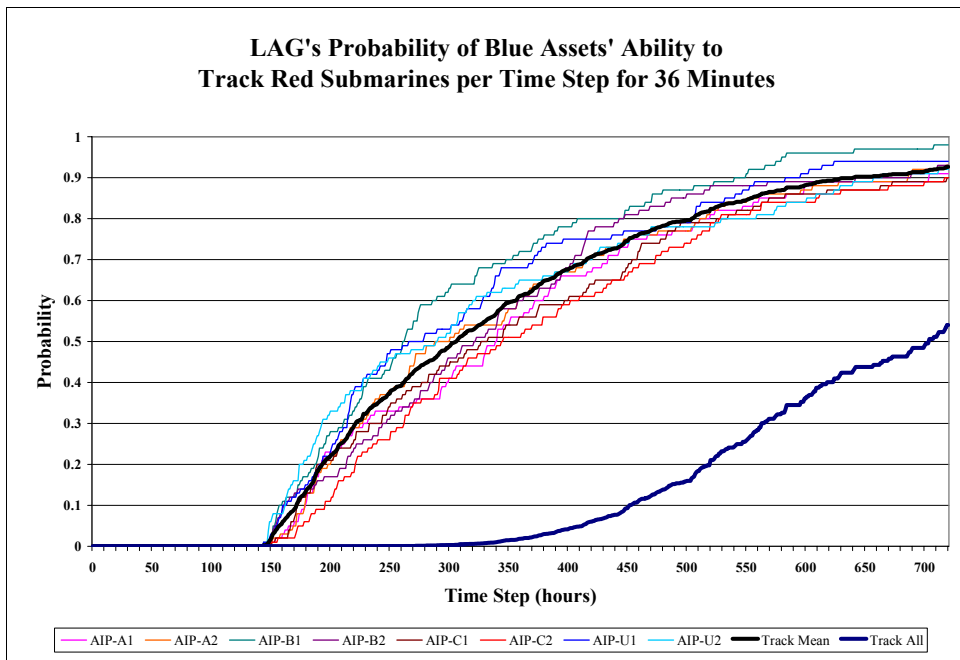
**Figure 161: Probability that Blue Assets can Successfully Track Red Submarines per Time Step in 18 Minutes for LAG Alternative**



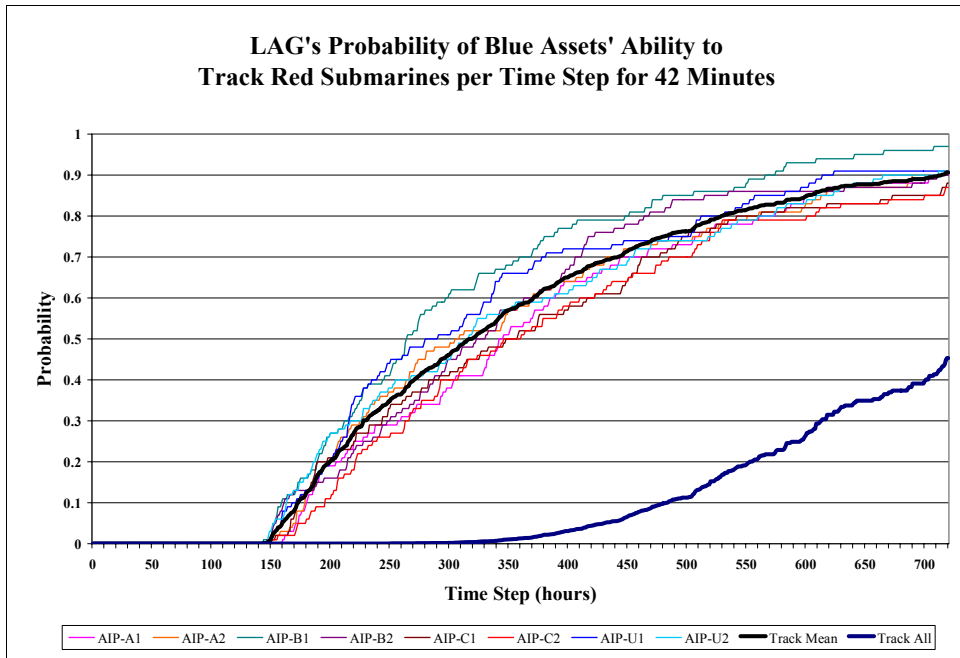
**Figure 162: Probability that Blue Assets can Successfully Track Red Submarines per Time Step in 24 Minutes for LAG Alternative**



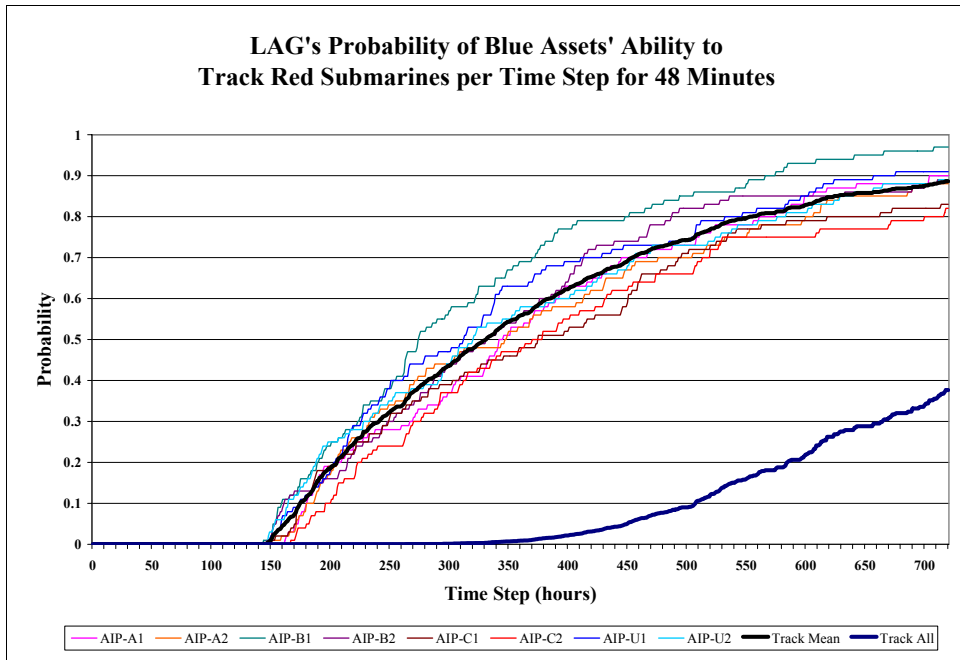
**Figure 163: Probability that Blue Assets can Successfully Track Red Submarines per Time Step in 30 Minutes for LAG Alternative**



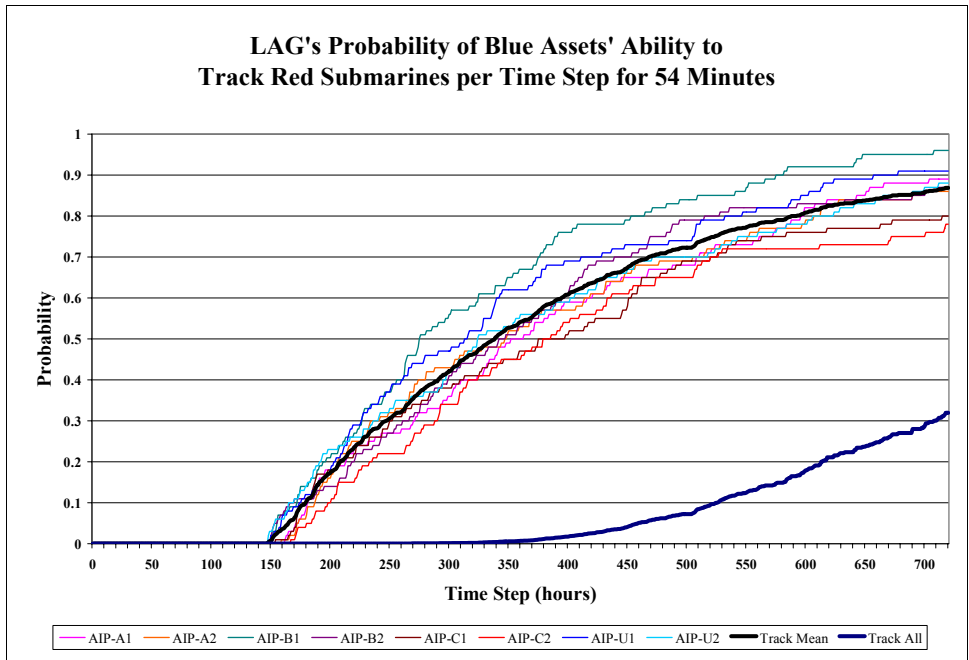
**Figure 164: Probability that Blue Assets can Successfully Track Red Submarines per Time Step in 36 Minutes for LAG Alternative**



**Figure 165: Probability that Blue Assets can Successfully Track Red Submarines per Time Step in 42 Minutes for LAG Alternative**



**Figure 166: Probability that Blue Assets can Successfully Track Red Submarines per Time Step in 48 Minutes for LAG Alternative**



**Figure 167: Probability that Blue Assets can Successfully Track Red Submarines per Time Step in 54 Minutes for LAG Alternative**

## APPENDIX C: COST ANALYSIS

### C.1 INTRODUCTION

Cost estimating, as part of a total systems analysis, provides an analytic underpinning to support decision makers. A cost analysis helps to decide which of the possible alternatives is more desirable and recommends a course of action that will steer decision makers towards it and away from undesirable alternatives.<sup>279</sup>

In understanding the costs associated with different alternatives, each alternative has been assessed regarding its component breakdown and, using historical data on actual or analogous assets, cost estimations for enabling each alternative are presented. In most cases, particular assumptions were made regarding each alternative. The following assumptions were made applicable to all of the alternatives:

- 1) Continuity of leadership, funding, and focus towards the ASW mission (i.e. the same resources, level-of-effort, and technical attention that exists for ASW will continue 20 years into the future).<sup>280</sup> Therefore, when stating “sunk costs, not applicable,” this assumption is directly applied
- 2) Little pertinent historical data exists for UUVs as PORs or for Operating and Support costs (O&S). Therefore, the range of 5% to 15% of Total Procurement was assumed for projected O&S costs per year
- 3) The projected O&S cost per year was scaled to fit the proposed timeline for each asset while operating (i.e., hours for aircraft delivery missions, 30 days of operation for an LCS, etc.)
- 4) All dollars are in FY05\$ dollars
- 5) Research and Development costs (R&D). Those program costs primarily associated with R&D efforts including the development of new or improved capability to the point where it is appropriate for operational use<sup>281</sup>
- 6) Procurement costs. Equal to the sum of procurement cost for prime mission equipment, the procurement cost for support items, and the

---

<sup>279</sup> Daniel Nussbaum, OA4702 – Cost Estimation, Naval Postgraduate School, Monterey, CA, 27 August 2005.

<sup>280</sup> Phil DePoy, “From Research to Reality: A Retrospective on the Development and Acquisition of Naval Capabilities During the Cold War Era,” (transcript of roundtable forum, 27 July 2005), pp. 104-105.

<sup>281</sup> *Defense Acquisition Acronyms and Terms*, Eleventh Edition, September 2003.

procurement cost for initial spares.<sup>282</sup> Also, expendable assets have Procurement costs equal to O&S costs

- 7) Learning/Improvement Curve Theory used to better estimate cumulative Procurement costs for multiple units. As defined in Defense Acquisition Acronyms and Terms, the Learning/Improvement Curve is “a mathematical way to explain and measure the rate of change of cost (in hours or dollars) as a function of quantity.”<sup>283</sup> This theory states that “If there is learning in the production process, the cumulative average cost of some doubled unit equals the cumulative average cost of the undoubled unit times the slope of the learning curve”
- 8) O&S. Those resources required to operate and support a system, subsystem, or a major component during its useful life in the operational inventory<sup>284</sup>

## C.2 ALTERNATIVE 1: TRIPWIRE

Coverage: 10 NM x 10 NM area

Assets:	<u>Quantity</u>	<u>Type</u>
	2	B-2s
	2	B-52s
	150	Netted-sensor components (expendable)
	15	21-inch Autonomous UUVs (expendable)

Assumptions: B-2 B-2s will fly a 20-hour mission from Whiteman AFB, MO. R&D and procurement costs for these aircraft are “sunk costs” and will not be considered

B-52 B-52s will fly an 8-hour mission from Anderson AFB, Guam. R&D and Procurement costs for these aircraft are “sunk costs” and will not be considered

Netted-Sensor Netted-sensor components analogous to StarLite<sup>285</sup>  
Sensor System

---

<sup>282</sup> Ibid.

<sup>283</sup> Ibid.

<sup>284</sup> Ibid.

21-inch UUV 21-inch UUV analogous to REMUS UUV system<sup>286</sup>

Calculations: B-2

R&D: Sunk costs, not applicable

Procurement: Sunk costs, not applicable

O&S: Two B-2s at a rate of \$15,130 per hour<sup>287</sup> =  
(2)\*(20 hours)\*(\$15,130) = \$605,200

B-52

R&D: Sunk costs, not applicable

Procurement: Sunk costs, not applicable

O&S: Two B-52s at a rate of \$16,101 per hour<sup>288</sup> =  
(2)\*(8 hours)\*(\$16,101) = \$257,616

Netted-Sensor R&D: \$2,000,000<sup>289</sup>

Procurement: Same as O&S (expendable asset)

O&S: 150 components at \$200,000 per component<sup>290</sup>  
(includes connecting fiber optic cable) = (150)\*(\$200,000)  
= \$30,000,000

21-inch UUV R&D: \$3,500,000 (cost given for development of  
6 REMUS UUVs)<sup>291</sup>

Procurement: Same as O&S (expendable asset)

O&S: See below.

Given the above assumption that the 15 UUVs are analogous to the current REMUS UUV, the total lot cost for 15 UUVs was estimated across a spectrum of UUV capabilities. Procurement data was estimated between more-capable and a less-capable UUVs, as well as comparisons made to Learning/Improvement Curves used in

---

<sup>285</sup> Phone conversation with Mr. Richard Haas, Systems Engineer at Planning Systems, based on an unsolicited bid to SOCOM for StarLite, on 3 November 2005.

<sup>286</sup> Phone conversation with Mr. Christopher J. Van Alt, Woods Hole Oceanographic Institute (WHOI), about REMUS and comparable UUV systems, on 2 November 2005.

<sup>287</sup> Air Force Total Ownership Costs, O&S revised rates as of 21 September 2005,  
<https://aftoc.hill.af.mil/AFI65503/15-1/15-1Sep05.xls>, (accessed 1 November 2005).

<sup>288</sup> Ibid.

<sup>289</sup> Phone conversation with Mr. Richard Haas, Systems Engineer at Planning Systems, based on an unsolicited bid to SOCOM for StarLite, on 3 November 2005.

<sup>290</sup> Ibid.

<sup>291</sup> Phone conversation with Mr. Christopher J. Van Alt, WHOI, about REMUS and comparable UUV systems, on 2 November 2005.

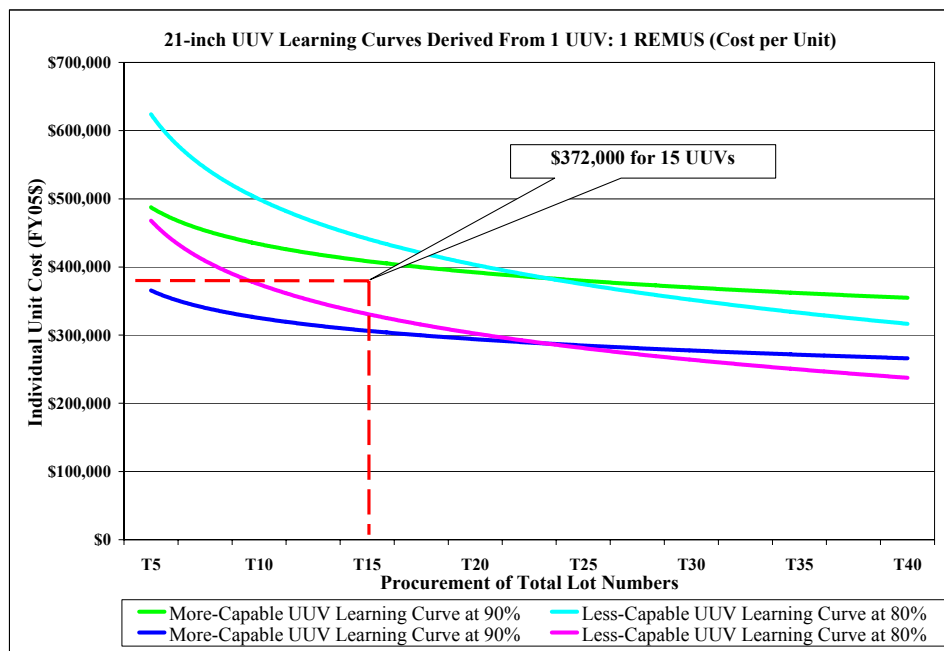
production. Therefore, calculating the cumulative total costs for a Lot size of 15 UUVs, the following equation was used:<sup>292</sup>

$$CTN = [TI * (N)^{(b+1)}] / (b + 1),$$

**Equation 12: CTN, Cumulative Cost of Total Lot Size**

where *TI* is the cost of first production unit, *N* is the total number of units in lot size, and *b* is the learning curve slope.

As depicted in Figure 168, for different Learning Curves where Lot size equals 15, the Cost per Unit and Cost per Lot Total can be calculated based on 80% and 90% improvement.



**Figure 168: 21-inch UUV Learning Curves Showing Average Cost Per Unit of \$372,000 for 15 UUVs**

Using the 80% Learning Curve derives the following numbers:

- More-capable CTN of 15 = \$6,590,000
- Less-capable CTN of 15 = \$4,940,000

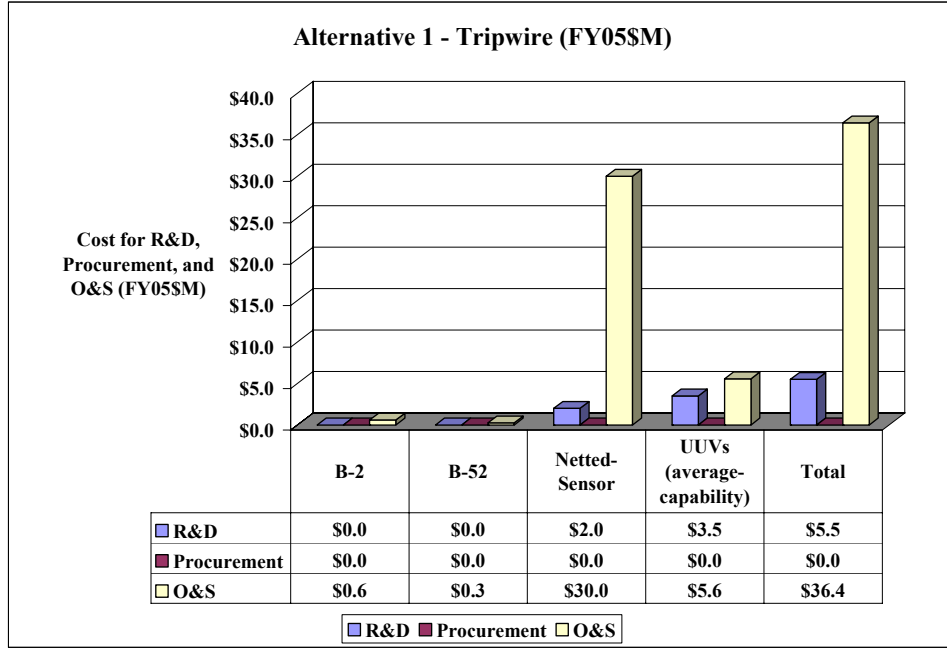
Using a 90% Learning Curve derives the following numbers:

- More-capable CTN of 15 = \$6,160,000 and
- Less-capable CTN of 15 = \$4,620,000

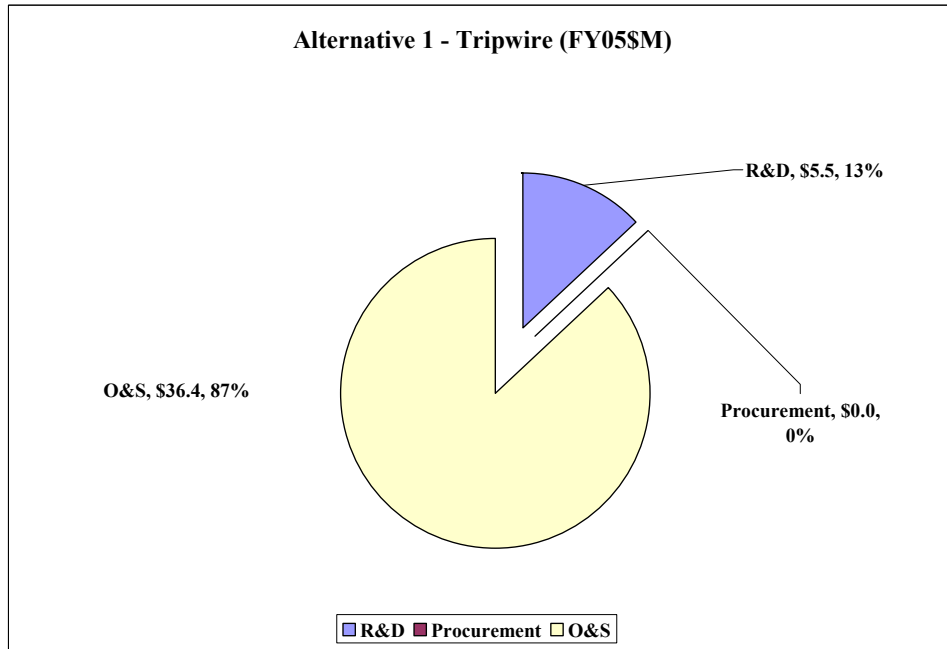
<sup>292</sup> Daniel Nussbaum, "OA4702 – Cost Estimation," Naval Postgraduate School, Monterey, CA, 20 September 2005.



The average of the above numbers leads to Procurement costs for Average-capable UUVs of Lot size 15 to \$5,580,000. For this asset, Procurement Costs equal O&S costs. This generates the following data represented in Figures 169 and 170.



**Figure 169: Alternative 1 - Tripwire - Showing Breakdown of R&D, Procurement, and O&S Funding**



**Figure 170: Alternative 1 - Tripwire - Showing Percentages of R&D, Procurement, and O&S Funding**

### C.3 ALTERNATIVE 2: TSSE SEA TENTACLE

Coverage: 100 NM x 67 NM area, multiplied by three ships

Assets:	<u>Quantity</u>	<u>Type</u>
	3	TSSE Sea TENTACLE Ships
	120-150	Large Vehicle UUVs <sup>293</sup>
	120-150	Dual 21-inch sleds
	1,920-2,400	9-inch UUVs
	720-900	12.75-inch UUVs
	6	FireScout UAVs
	6	Spartan Scout USVs
	3	MH-60s
Assumptions: TSSE Ship		Three TSSE Sea TENTACLE ships are being used, configured for ASW load-out. Other components non-ASW related that were stored on the ships were not calculated for cost-related purposes
Large UUV		Large Vehicle UUV analogous to Large Sea Predator UUV <sup>294</sup>
UUV Sled		Dual 21-inch sleds analogous to 1 REMUS UUV. Consideration is given to size more than doubling, complexity staying the same, navigation/propulsion being minimal by comparison. R&D costs assumed to be uniform for UUV Sleds, 9-inch UUVs, and 12.75-inch UUVs
9-inch UUV		9-inch UUVs analogous to one-half of 1 REMUS UUV. Consideration is given to halving the size, navigation staying the same, and propulsion and complexity being minimal by comparison. R&D costs assumed to be uniform for UUV Sleds, 9-inch UUVs, and 12.75-inch UUVs
12.75-inch UUV		12.75-inch UUVs analogous to two-thirds of 1 REMUS UUV. Consideration is given to size being about 0.6 of

<sup>293</sup> *The Navy Unmanned Undersea Vehicle (UUV) Master Plan*, 9 November 2004.

<sup>294</sup> David DeMartino, Chief Engineer at Naval Surface Warfare Center, Panama City, FL, (unpublished cost data for Sea Predator), 2 November 2005.

REMUS, navigation staying the same, complexity being altered for unique charging and communications missions, and propulsion being minimal. R&D costs assumed to be uniform for UUV Sleds, 9-inch UUVs, and 12.75-inch UUVs

FireScout FireScout<sup>295</sup> UAV is currently in production. R&D and Procurement costs for these aircraft are “sunk costs” and will not be considered for this alternative

Spartan Scout Spartan Scout USV is currently in production. R&D and Procurement costs for these vessels are considered “sunk costs” and will not be considered for this alternative

MH-60 Current MH-60 data is insufficient to produce useable forecast. Therefore, the MH-60 is assumed analogous to the current SH-60. R&D and Procurement costs for these aircraft are considered “sunk costs” and will not be considered for this alternative

Calculations: Sea TENTACLE R&D: \$500,000,000<sup>296</sup>

Procurement: \$900,000,000.<sup>297</sup> Therefore (\$900,000,000) \* (3 units) = \$2,700,000,000

O&S: Using the range of 5% to 15% of Procurement costs equals annual O&S costs, derives a mid-point O&S of 10% cost per month = (\$900,000,000)\*(10%)\*(3 Ships) / (12 months) = \$22,500,000 per month<sup>298</sup>

Large UUV R&D: Given the above analogy to the Sea Predator R&D costs were on the order of \$20,000,000. This should roughly translate into about the same amount of a

---

<sup>295</sup> Defense Industry Daily, “The FireScout VTUAV Program: By Land and Sea (updated),” [http://www.defenseindustrydaily.com/2005/10/the-fire-scout-vtuav-program-by-land-and-by-sea-updated/index.php#orison\\_mc](http://www.defenseindustrydaily.com/2005/10/the-fire-scout-vtuav-program-by-land-and-by-sea-updated/index.php#orison_mc), (accessed 9 November 2005).

<sup>296</sup> Jason Hall, “Total Ship Systems Engineering (TSSE) Sea TENTACLE,” (initial draft, unpublished report) 19 November 2005.

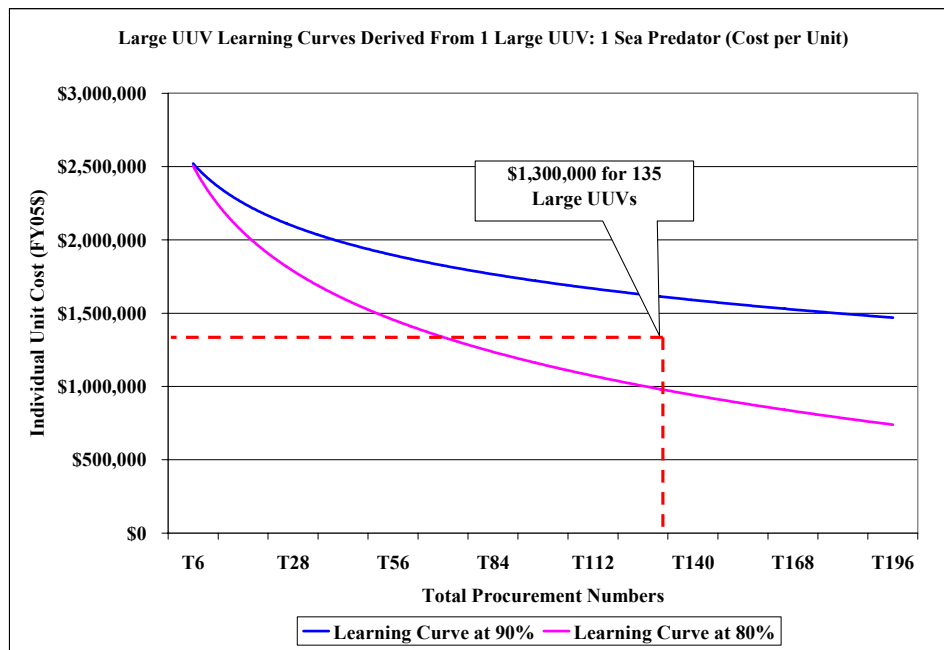
<sup>297</sup> Ibid.

<sup>298</sup> Jason Hall, “Total Ship Systems Engineering (TSSE) Sea TENTACLE,” (initial draft, unpublished report) 19 November 2005.

conversion from Sea Predator to Sea Tentacle (actual data is R&D cost converting the Sea Predator from the ASDS).  
Therefore, R&D costs = \$20,000,000

Procurement: See below

As depicted in Figure 171, for different Learning Curves, where Lot size equals 120 and 150, the cost per unit and cost per Lot Total can be calculated based on 80% and 90% improvement.



**Figure 171: Large UUV Learning Curves Showing Average Cost Per Unit \$1,300,000 for 135 Large UUVs**

Therefore, using an 80% Learning Curve derives the following numbers:

- CTN of 120 = \$122,600,000
- CTN of 150 = \$142,700,000

Using a 90% Learning Curve derives the following numbers:

- CTN of 120 = \$196,600,000
- CTN of 150 = \$237,600,000

The average of the above numbers leads to a CTN midpoint of 135, where Procurement costs = \$174,900,000.

O&S: Using the range of 5% to 15% of Procurement costs equals annual O&S costs, derives a mid-point O&S of 10%

cost per month =  $(\$174,900,000) \times (10\%) / (12 \text{ months}) =$   
\$1,460,000 per month

UUV Sled R&D: \$3,500,000<sup>299</sup> (assumed equivalent R&D dollars  
needed to develop UUV Sled as REMUS UUV)

Procurement: See below

As depicted in Figure 172, for different Learning Curves, where Lot size equals 120 and 150, the cost per unit and cost per Lot Total can be calculated based on 80% and 90% improvement. Therefore, using a 80% Learning Curve derives the following numbers:

- More-capable CTN of 120 = \$20,200,000 and
- Less-capable CTN of 120 = \$26,900,000
- More-capable CTN of 150 = \$23,500,00 and
- Less-capable CTN of 150 = \$31,400,000

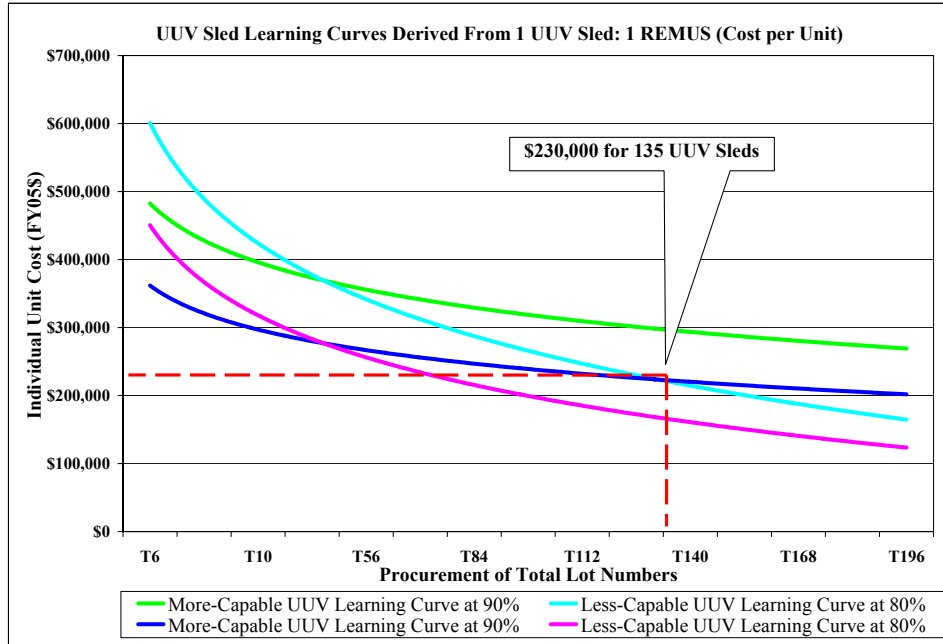
Using a 90% Learning Curve derives the following numbers:

- More-capable CTN of 120 = \$26,900,000
- Less-capable CTN of 120 = \$35,900,000
- More-capable CTN of 150 = \$ 32,500,000
- Less-capable CTN of 150 = \$43,400,000

The average of the above numbers leads to CTN mid-point of 135, where Procurement costs = \$31,100,000.

---

<sup>299</sup> Phone conversation with Mr. Christopher J. Van Alt, WHOI, about REMUS and comparable UUV systems, on 2 November 2005.



**Figure 172: UUV Sled Learning Curves Showing Average Cost Per Unit \$230,000 for 135 UUV Sleds**

O&S: Using the range of 5% to 15% of Procurement costs equals annual O&S costs derives a mid-point O&S of 10% cost per month =  $(\$31,100,000) \cdot (10\%) / (12 \text{ months}) = \$250,000$  per month

9-inch UUV R&D:  $\$3,500,000^{300}$  (assumed equivalent R&D dollars needed to develop 9 Inch UUV as REMUS UUV)

Procurement: See below

As depicted in Figure 173, for different Learning Curves, where Lot size equals 1,920 and 2,400, the cost per unit and cost per Lot Total can be calculated, based on 80% and 90% improvement. Therefore, using an 80% Learning Curve derives the following numbers:

- More-capable CTN of 1920 = \$88,400,000 and
- Less-capable CTN of 1920 = \$66,300,000
- More-capable CTN of 2400 = \$102,900,000 and
- Less-capable CTN of 2400 = \$77,200,000

Using a 90% Learning Curve derives the following numbers:

<sup>300</sup> Phone conversation with Mr. Christopher J. Van Alt, WHOI, about REMUS and comparable UUV systems, on 2 November 2005.

- More-capable CTN of 1920 = \$188,400,000 and
- Less-capable CTN of 1920 = \$141,300,000
- More-capable CTN of 2400 = \$227,700,000 and
- Less-capable CTN of 2400 = \$107,800,000

The average of the above numbers leads to a CTN midpoint of 2,160, where Procurement costs = \$125,000,000.

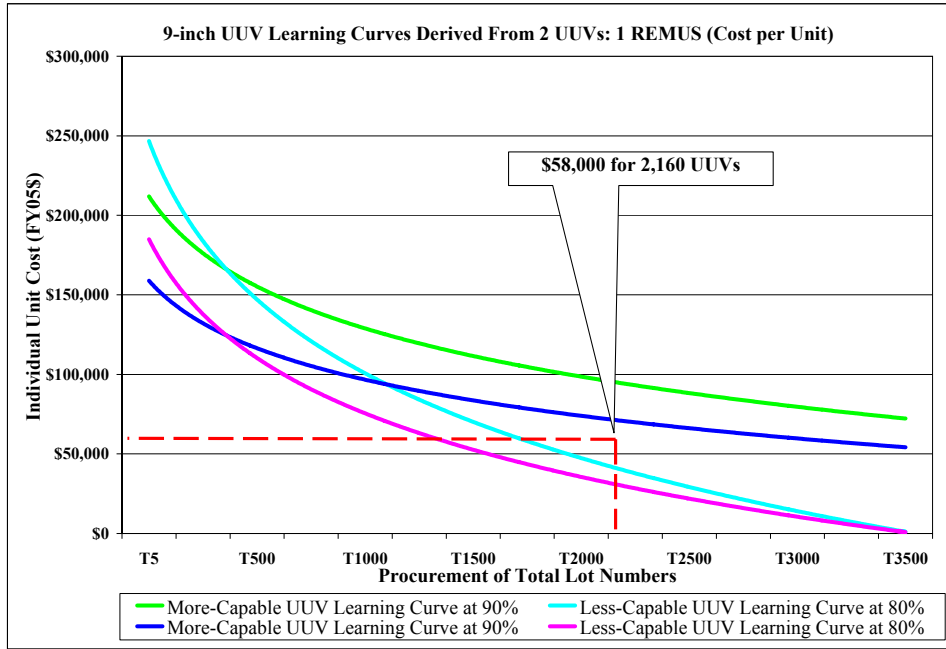


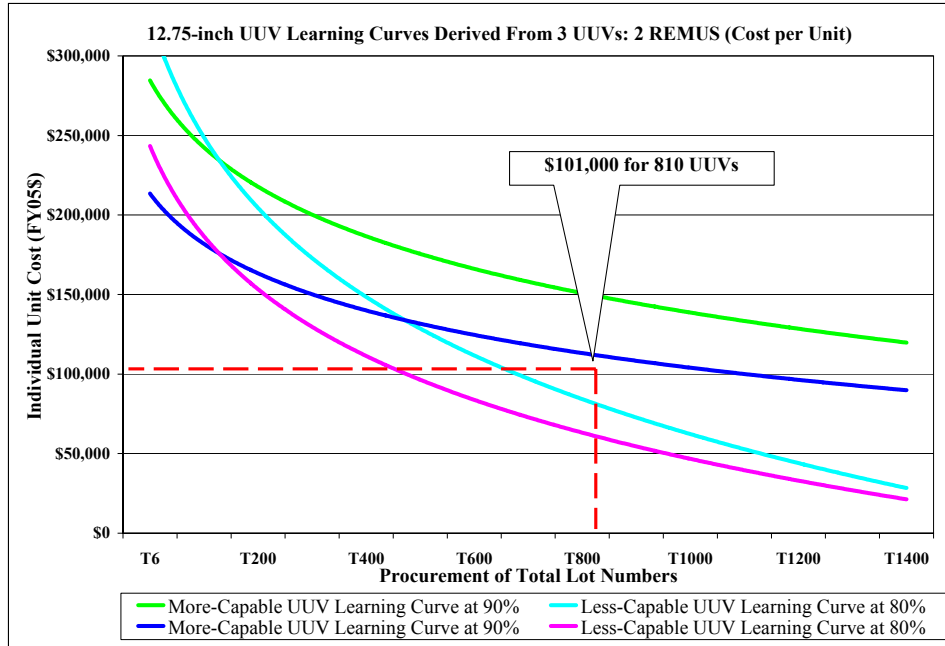
Figure 173: 9-inch Learning Curves Showing Average Cost Per Unit \$58,000 for 2,160 UUVs

O&S: Using the range of 5%-15% of Procurement costs equals annual O&S costs, derives a midpoint O&S of 10% cost per month =  $(\$125,000,000) \cdot (10\%) / (12 \text{ months}) = \$1,040,000$  per month

12.75-inch UUV R&D: \$3,500,000<sup>301</sup> (assumed equivalent R&D dollars needed to develop 12.75-inch UUV as REMUS UUV).

Procurement: See below

<sup>301</sup> Phone conversation with Mr. Christopher J. Van Alt, WHOI, about REMUS and comparable UUV systems, on 2 November 2005.



**Figure 174: 12.75-inch Learning Curves Showing Average Cost Per Unit \$101,000 for 810 UUVs**

As depicted in Figure 174, for different Learning Curves, where Lot size equals 720 and 900, the cost per unit and cost per Lot Total can be calculated, based on 80% and 90% improvement. Therefore, using an 80% Learning Curve derives the following numbers:

- More-capable CTN of 720 = \$60,600,000 and
- Less-capable CTN of 720 = \$45,500,000
- More-capable CTN of 900 = \$70,500,000 and
- Less-capable CTN of 900 = \$52,900,000

Using a 90% Learning Curve derives the following numbers:

- More-capable CTN of 720 = \$109,300,000 and
- Less-capable CTN of 720 = \$82,000,000
- More-capable CTN of 900 = \$132,000,000 and
- Less-capable CTN of 900 = \$99,100,000

The average of the above numbers leads to a CTN midpoint of 810, where Procurement costs = \$81,500,000.

O&S: Using the range of 5% to 15% of Procurement costs equals annual O&S costs derives a midpoint O&S of 10%



cost per month =  $(\$81,500,000) * (10\%) / (12 \text{ months}) =$   
\$680,000 per month

FireScout R&D: Sunk costs, not applicable  
Procurement: Sunk costs, not applicable  
O&S: Based on a 2004 contract to Northrop Grumman Corporation for procurement of 2 FireScout assets for \$49,000,000<sup>302</sup>, therefore  $(\$49,000,000) / (2 \text{ FireScouts}) =$  \$24,500,000 per unit. Using the range of 5%-15% of Procurement costs equals annual O&S costs, derives a mid-point O&S of 10% cost per month =  $(\$24,500,000) * (10\%) * (6 \text{ units}) / (12 \text{ months}) =$  \$1,225,000 per month

Spartan Scout R&D: Sunk costs, not applicable  
Procurement: Sunk costs, not applicable  
O&S: A Procurement cost of one Spartan asset for \$120,000<sup>303</sup> was provided by the NUWC. Using the range of 5% to 15% of Procurement costs equals annual O&S costs, derives a midpoint O&S of 10% cost per month =  $(\$120,000) * (10\%) * (6 \text{ Spartan Scouts}) / (12 \text{ months}) =$  \$6,000 per month

MH-60 R&D: Sunk costs, not applicable  
Procurement: Sunk costs, not applicable  
O&S: \$3,200,000<sup>304</sup> per year, therefore  $(\$3,200,000) / (12 \text{ months}) * (3 \text{ MH-60s}) =$  \$800,000 per month

This generates the following data represented in Figures 175 and 176.

---

<sup>302</sup> Department of Defense, Contracts, Defense Logistics Agency, <http://www.defenselink.mil/contracts/2004/ct20040302.html>, (accessed 18 November 2005).

<sup>303</sup> SPAWAR Technical Database, Unmanned Surface Vehicles, Spartan, <http://robot.spawar.navy.mil/home.asp?item=details&order=&sort=&page=1&cat=plat&sub=USV&id=35>, (accessed 19 November 2005).

<sup>304</sup> Navy Visibility and Management of Operating and Support Costs (VAMOSC), SH-60 O&S data accumulated for FY2004, <http://www.navyvamosc.com/>, (accessed 7 November 2005).

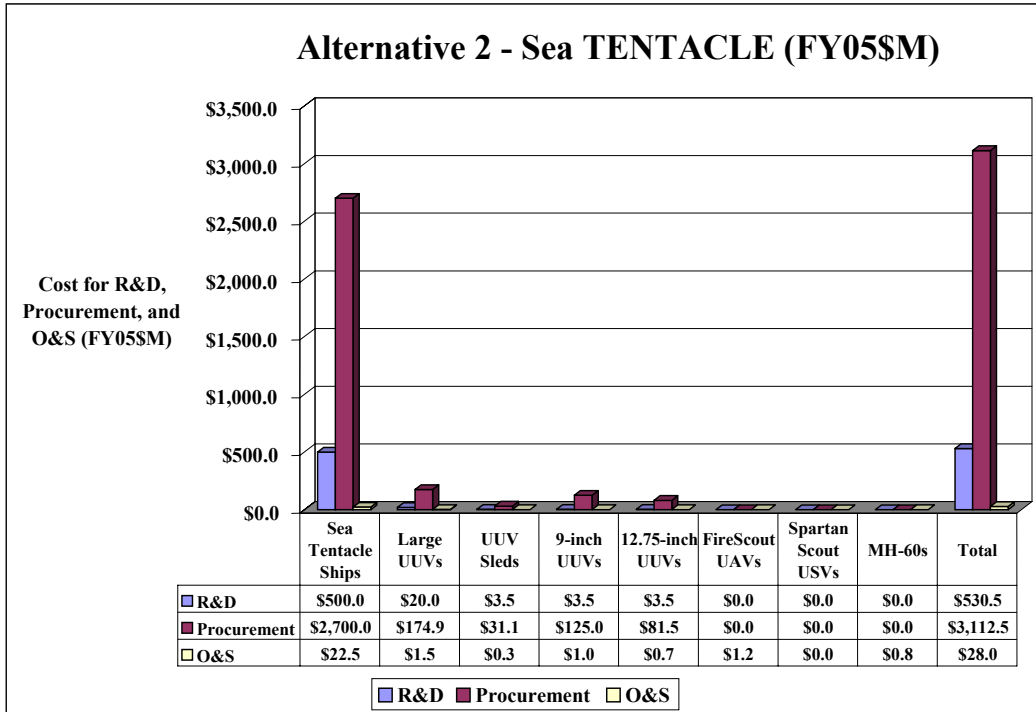


Figure 175: Alternative 2 - Sea TENTACLE - Showing Breakdown of R&D, Procurement, and O&S Funding

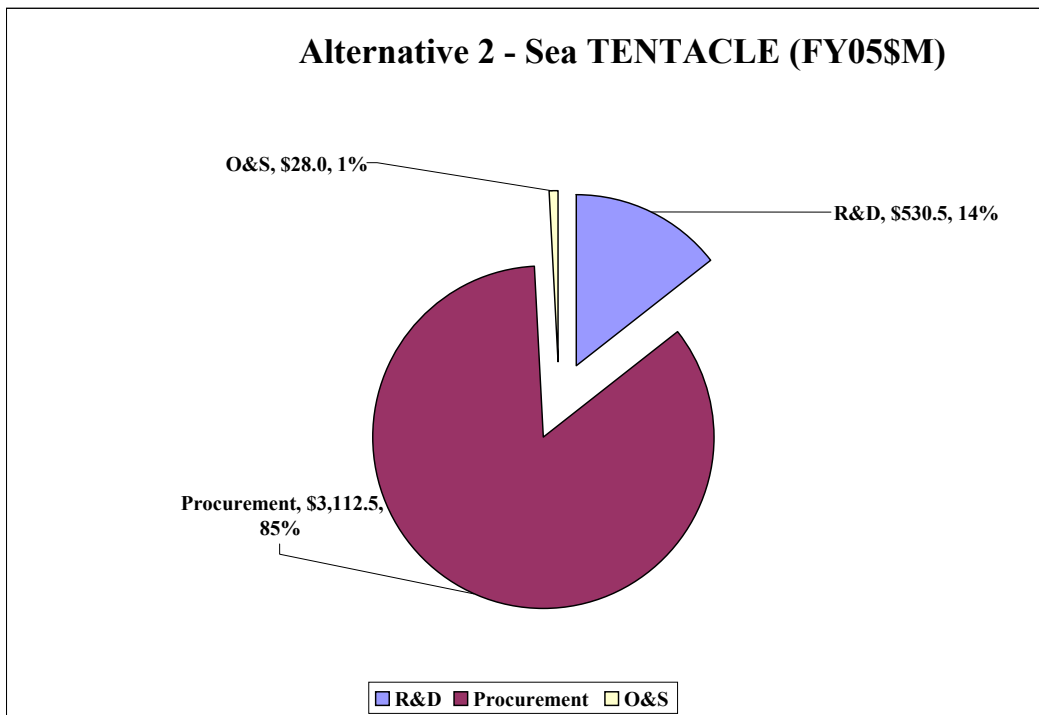


Figure 176: Alternative 2 - Sea TENTACLE - Showing Percentages of R&D, Procurement, and O&S Funding

#### C.4 ALTERNATIVE 4: WAR OF MACHINES

Coverage: 100 NM x 200 NM area

Assets:	<u>Quantity</u>	<u>Type</u>
	4	B-2s
	4	B-52s
	12	Recharging Stations
	60	21-inch Autonomous UUVs
	2	SSGNs

Assumptions: B-2	B-2s will fly a 20-hour mission from Whiteman AFB, MO. R&D and Procurement costs for these aircraft are ‘sunk costs’ and will not be considered for this alternative
B-52	B-52s will fly an 8-hour mission from Anderson AFB, Guam. R&D and Procurement costs for these aircraft are “sunk costs” and will not be considered for this alternative
Recharging	Recharging Stations to be deployed and recovered by SSGNs. Recharging Stations also assumed to be analogous to the REMUS UUV <sup>305</sup>
21-inch UUV	21-inch UUV analogous to twice that of 1 REMUS UUV system. <sup>306</sup> Consideration is given to increase in recharging capability, coordinated communications, interoperability, and performance. UUVs to be deployed by B-2/B-52, and recovered by SSGNs
SSGN	SSGNs not used during 30-day operating window, except to recover Recharging Stations and UUVs. One week of operation considered for recovery time. R&D and Procurement costs for these boats are considered ‘sunk costs’ and will not be considered for this alternative

Calculations: B-2                      R&D: Sunk costs, not applicable

---

<sup>305</sup> Phone conversation with Mr. Christopher J. Van Alt, WHOI, about REMUS and comparable UUV systems, on 2 November 2005.

<sup>306</sup> Ibid.

Procurement: Sunk costs, not applicable

O&S: Four B-2s, at a rate of \$15,130 per hour<sup>307</sup> =  
(4)\*(20 hours)\*(\$15,130) = \$1,210,400

B-52

R&D: Sunk costs, not applicable

Procurement: Sunk costs, not applicable

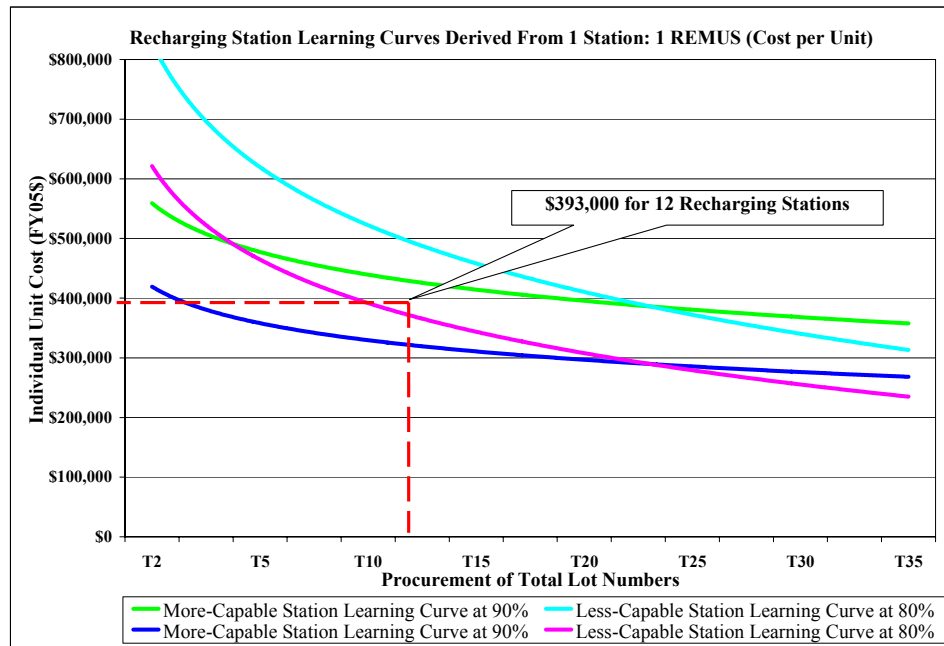
O&S: Four B-52s flying at a rate of \$16,101 per hour<sup>308</sup> =  
(4) \* (8 hours)\*(\$16,101) = \$515,232

Recharging

R&D: \$3,500,000<sup>309</sup> (assumed equivalent R&D dollars needed to develop Recharging Station as REMUS UUV)

Procurement: See below

As depicted in Figure 177, for different Learning Curves, where Lot size equals 12, the cost per unit and cost per Lot Total can be calculated, based on 80% and 90% improvement.



**Figure 177: Recharging Station Learning Curves Showing Average Cost Per Unit \$393,000 for 12 Recharging Stations**

Therefore, using an 80% Learning Curve derives the following numbers:

<sup>307</sup> Air Force Total Ownership Costs, O&S revised rates as of 21 September 2005, <https://aftoc.hill.af.mil/AFI65503/15-1/15-1Sep05.xls>, (accessed 1 November 2005).

<sup>308</sup> Ibid.

<sup>309</sup> Phone conversation with Mr. Christopher J. Van Alt, WHOI, about REMUS and comparable UUV systems, on 2 November 2005.

- More-capable CTN of 12 = \$5,660,000 and
- Less-capable CTN of 12 = \$4,250,000

Using a 90% Learning Curve derives the following numbers:

- More-capable CTN of 12 = \$5,100,000 and
- Less-capable CTN of 12 = \$3,820,000

The average of the above numbers leads to CTN of 12, where Procurement costs = \$4,710,000.

O&S: Using the range of 5% to 15% of Procurement costs equals annual O&S costs, derives a midpoint O&S of 10% cost per month =  $(\$4,710,000) \times (10\%) / (12 \text{ months}) = \$39,000$  per month

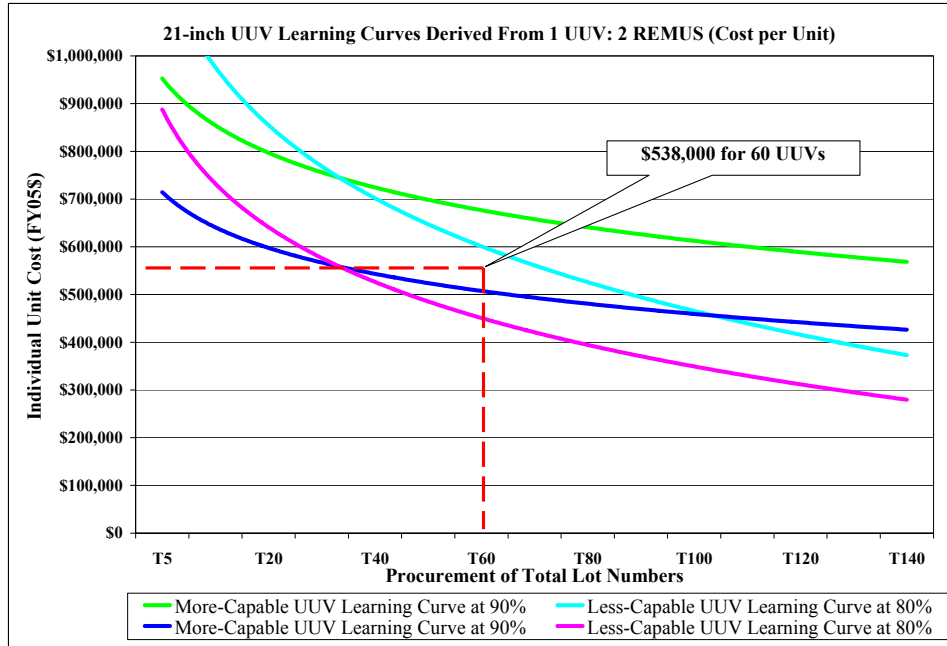
21-inch UUV R&D: \$3,500,000 (cost given for development of 6 REMUS UUVs)<sup>310</sup>

Procurement: See below

As depicted in Figure 178, for different Learning Curves, where Lot size equals 60, the cost per unit and cost per Lot Total can be calculated, based on 80% and 90% improvement.

---

<sup>310</sup> Phone conversation with Mr. Christopher J. Van Alt, WHOI, about REMUS and comparable UUV systems, on 2 November 2005.



**Figure 178: 21-inch Learning Curves Showing Average Cost Per Unit \$538,000 for 60 UUVs**

Therefore, using a 80% Learning Curve derives the following numbers:

- More-capable CTN of 60 = \$33,700,000 and
- Less-capable CTN of 60 = \$25,300,000

Using a 90% Learning Curve derives the following numbers:

- More-capable CTN of 60 = \$40,000,000 and
- Less-capable CTN of 60 = \$30,000,000

The average of the above numbers leads to CTN of 60, where Procurement costs = \$32,250,000.

O&S: Using the range of 5% to 15% of Procurement costs equals annual O&S costs derives a mid-point O&S of 10% cost per month =  $(\$32,250,000) \cdot (10\%) / (12 \text{ months}) = \$269,000$  per month

SSGN

R&D: Sunk costs, not applicable

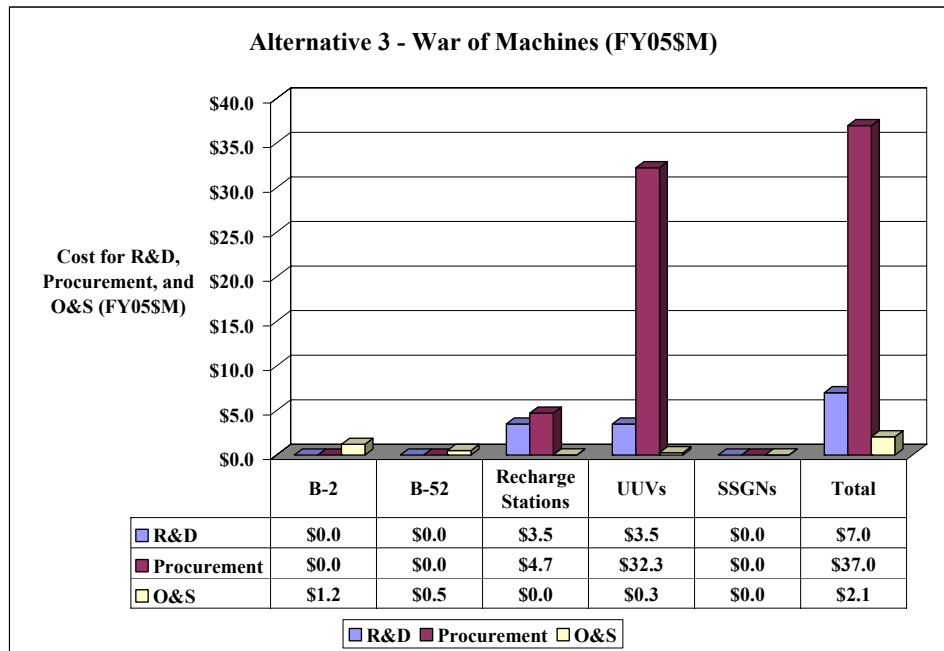
Procurement: Sunk costs, not applicable

O&S: Two SSGNs operating for one week to recover assets. Therefore, annual O&S rate of \$38,400,000 per

$$\text{year}^{311} = (2 \text{ SSGN}) * (\$38,400,000 \text{ per year}) / (52 \text{ weeks}) =$$

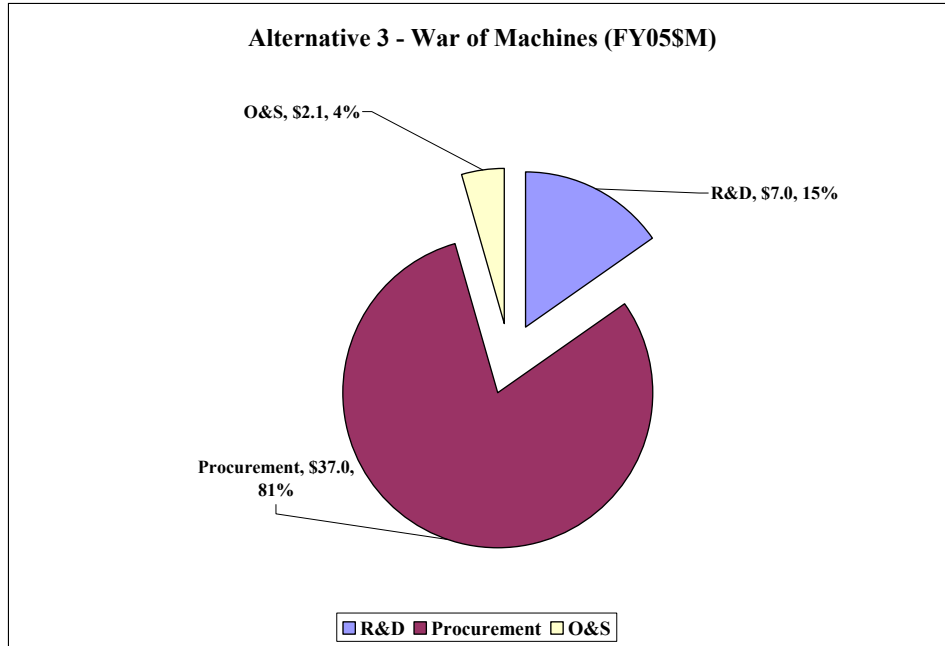
$$\$28,400 \text{ per week}$$

This generates the following data represented in Figures 179 and 180:



**Figure 179: Alternative 3 - War of Machines - Showing Breakdown of R&D, Procurement, and O&S Funding**

<sup>311</sup> Navy Visibility and Management of Operating and Support Costs (VAMOSC), SSGN O&S data accumulated for FY2004, <http://www.navyvamosc.com/>, (accessed 7 November 2005).



**Figure 180: Alternative 3 - War of Machines - Showing Percentages of R&D, Procurement, and O&S Funding**

**C.5 ALTERNATIVE 4: LAG**

Coverage: 100 NM x 200 NM area

Assets:	Quantity	Type
	1	DD(X)
	3	LCS
	2	SSNs
	5	MH-60s

Assumptions:	DD(X)	R&D and Procurement costs for these aircraft are “sunk costs” and will not be considered for this alternative
	LCS	LCS assumed analogous for O&S data to the FFG-7. R&D and Procurement costs for these aircraft are “sunk costs” and will not be considered for this alternative
	SSN	Current Virginia-class SSN data is insufficient to produce usable forecast, therefore Virginia SSN assumed analogous to current Los Angeles-class SSN for O&S data. R&D and Procurement costs for these aircraft are “sunk costs” and will not be considered for this alternative



MH-60 Current MH-60 data is insufficient to produce useable forecast, therefore the MH-60 assumed analogous to current SH-60 for O&S data; R&D and Procurement costs for these aircraft are “sunk costs” and will not be considered for this alternative

Calculations: DD(X) R&D: Sunk costs, not applicable  
Procurement: Sunk costs, not applicable  
O&S: 1 DD(X) operating at an O&S rate of \$41,500,000 per year<sup>312</sup> = (\$41,500,000 per year) / (12 months) = \$3,500,000 per month

LCS R&D – Sunk costs, not applicable  
Procurement – Sunk costs, not applicable  
O&S: Three LCSs operating at an O&S rate of \$26,100,000 per year<sup>313</sup> = (3 LCS)\*(\$26,100,000 per year) / (12 months) = \$6,520,000 per month

SSN R&D: Sunk costs, not applicable  
Procurement: Sunk costs, not applicable  
O&S: Two SSNs operating at an O&S rate of \$39,700,000 per year<sup>314</sup> = (2 SSNs)\*(\$39,700,000 per year) / (12 months) = \$6,260,000 per month

MH-60 R&D: Sunk costs, not applicable  
Procurement: Sunk costs, not applicable  
O&S: Five MH-60s operating at a rate of \$3,200,000<sup>315</sup> per year. Therefore (\$3,200,000 per year) / (12 months) \* (5 MH-60s) = \$1,330,000 per month

---

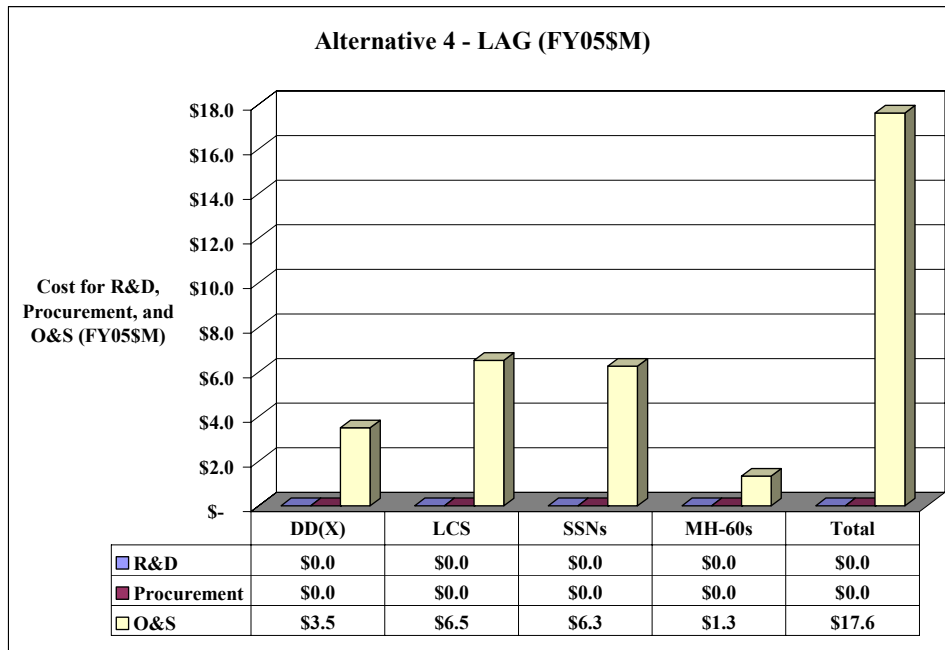
<sup>312</sup> Crystal Hauser, Northrop Grumman Corporation “DD(X)-avg.-annual-metric-cost” stated as \$40,0786,678 in TY02\$ (17 November 2005, converted to FY05\$ using Naval Cost Analysis Division SCN indexes of FY06-version 2).

<sup>313</sup> Navy Visibility and Management of Operating and Support Costs (VAMOSOC), FFG O&S data accumulated for FY2004, <http://www.navyvamosoc.com/>, (accessed 7 November 2005).

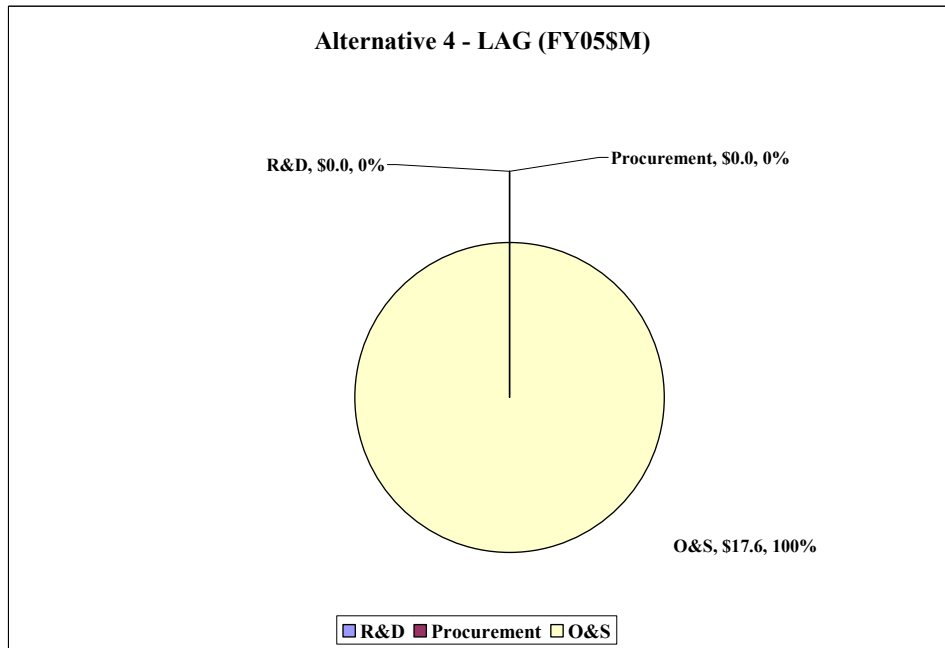
<sup>314</sup> Navy Visibility and Management of Operating and Support Costs (VAMOSOC), SSN O&S data accumulated for FY2004, <http://www.navyvamosoc.com/>, (accessed 7 November 2005).

<sup>315</sup> Ibid.

This generates the following data represented in Figures 181 and 182.



**Figure 181: Alternative 4 - LAG - Showing Breakdown of R&D, Procurement, and O&S Funding**



**Figure 182: Alternative 4 - LAG - Showing Breakdown of R&D, Procurement, and O&S Funding**

## C.6 COMPARISON OF ALTERNATIVES

After generating the above costing data, the results for R&D, Procurement, and O&S are summarized in Table 22 (all dollars in FY05\$). This data is also represented in Figures 183 (R&D), 184 (Procurement), 185 (O&S), and 186 (all costs by alternative).

Costs (FY05\$M)	Alternative 1 Tripwire	Alternative 2 Sea TENTACLE	Alternative 3 War of Machines	Alternative 4 LAG
<b>R&amp;D</b>	\$5,500,000	\$530,500,000	\$7,000,000	\$0
<b>Procurement</b>	\$0	\$3,112,500,000	\$37,000,000	\$0
<b>O&amp;S</b>	\$36,400,000	\$28,000,000	\$2,100,000	\$17,600,000

Table 22: Cost Comparison by Alternative (FY05\$M)

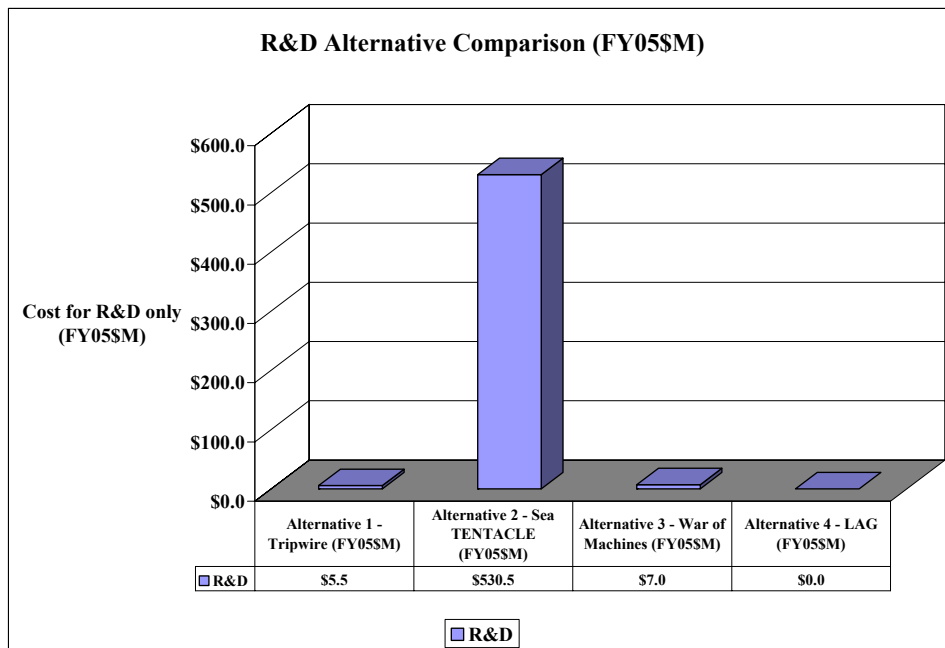
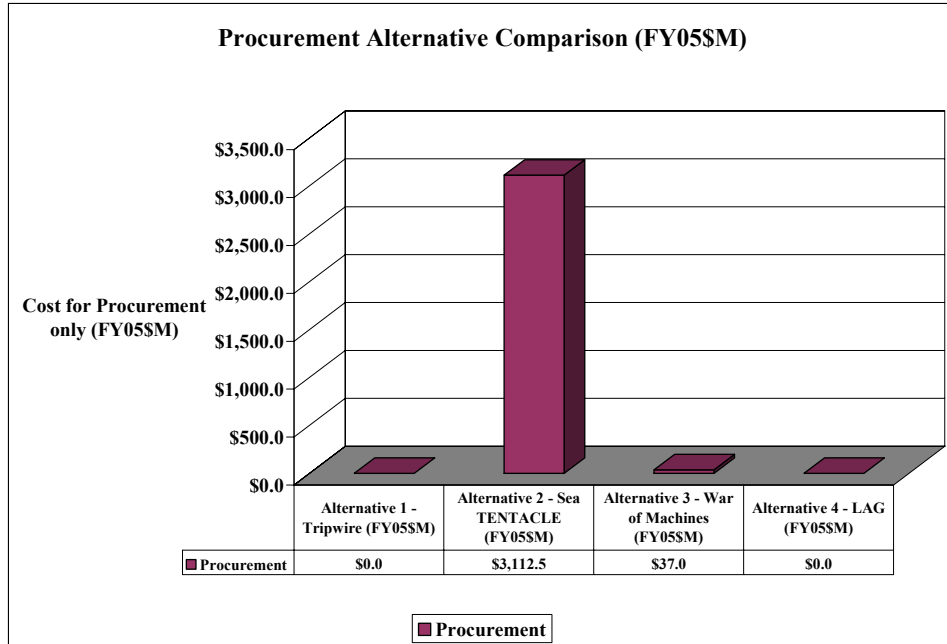
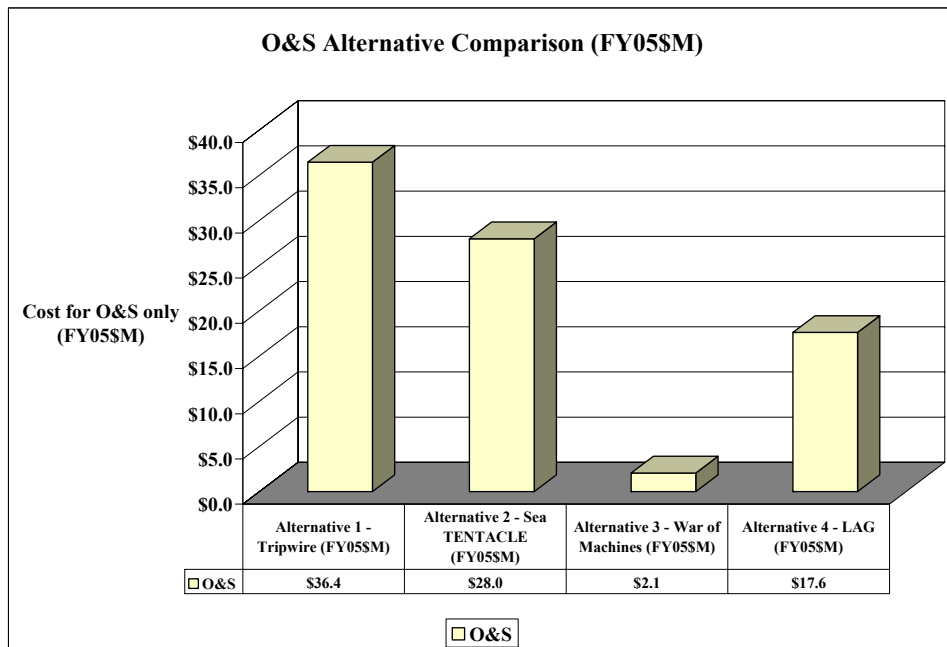


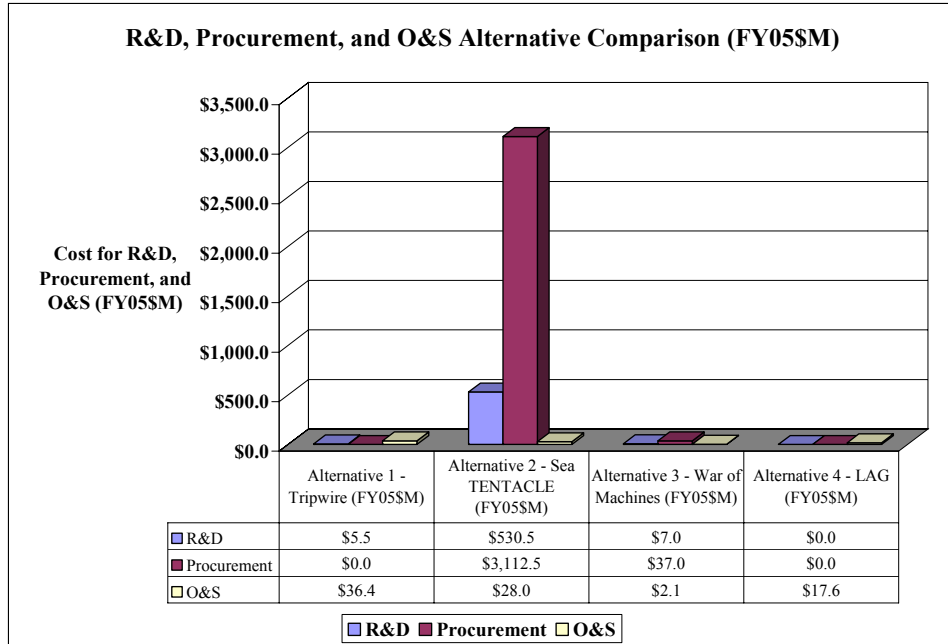
Figure 183: Comparison of Alternatives Across R&D Funding



**Figure 184: Comparison of Alternatives Across Procurement Funding**



**Figure 185: Comparison of Alternatives Across O&S Funding**



**Figure 186: Comparison of Alternatives Across R&D, Procurement, and O&S Funding**

## APPENDIX D: RELIABILITY AND SUSTAINABILITY

### D.1 RELIABILITY AND SUSTAINMENT MODELING

This chapter develops a model that portrays the availability of the system and its components. SEA-8's focus is on Alternative 3: War of Machines. This system must maintain enough UUVs to cover the 100 NM x 200 NM box for 30 days with 90% probability.

SEA-8 focused on scheduling maintenance as a policy decision. This illustrates one capability of our system model; others can be similarly handled. To demonstrate, both maintenance options will be modeled to determine the necessary reliability of the UUV to meet system goals (Equation 13).

$$P\left(\min_{(120 \text{ hours} \leq t \leq 720 \text{ hours})} \text{NumOperatingUUVs} \geq 40\right) \geq 0.90$$

**Equation 13: Probability that 40 or more UUVs are operating for 30 days with greater than 90% of simulations being greater than 40 UUVs over the defined time interval**

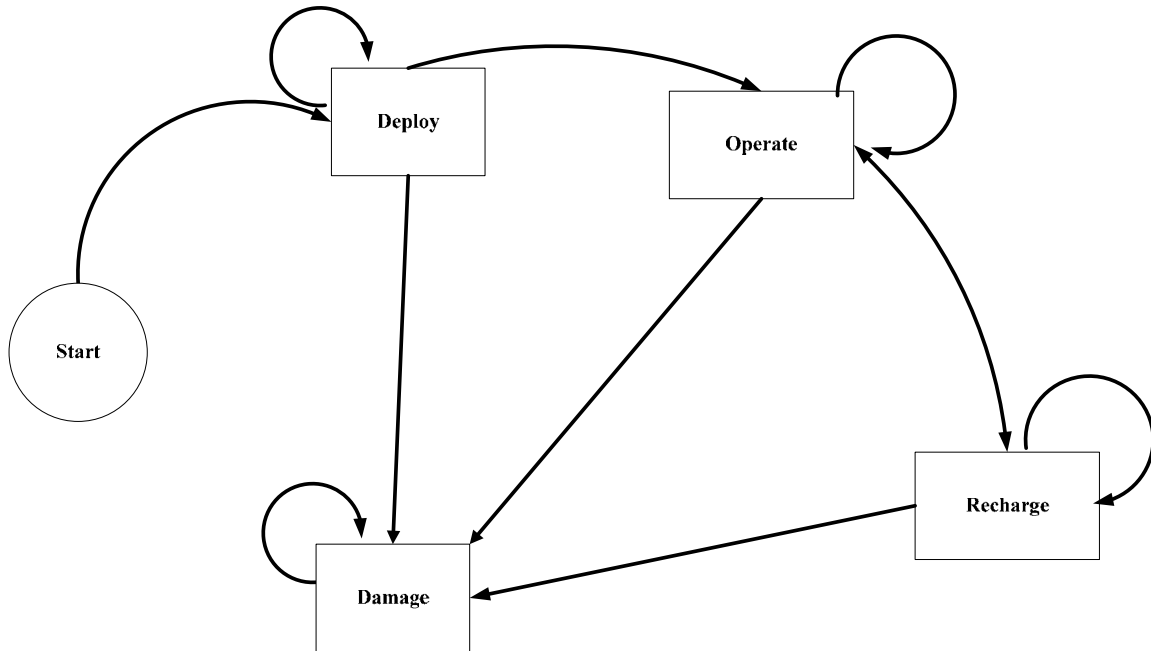
#### D.1.1 Modeling UUV Reliability

Reliability of a UUV is the probability that it will perform its functions of search, track, and trail enemy submarines in the littorals without failure during a specified time. The reliability of an individual UUV affects many issues:

- Do you retrieve the UUVs for maintenance or not?
- How many UUVs to initially deploy?
- How often to reseed the AOR with UUVs?
- Whether to deploy UUVs early or consistently over time?
- How often the UUVs should begin to recharge?

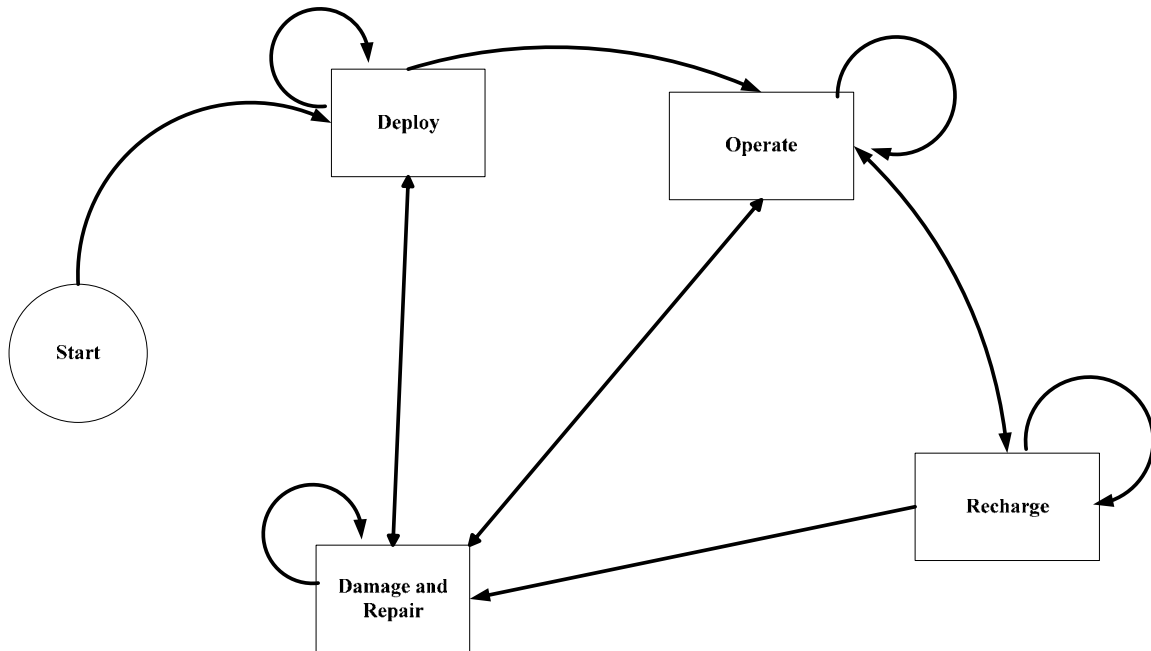
First, a UUV system without a maintenance capability was modeled. As shown in Figure 187, because the system does not have maintenance support, UUVs that are damaged during the course of operations become unavailable for further use. According to Section 3.3.5.3 Alternative 3: War of Machines, a minimum number of 40 operating UUVs are required to be actively searching an area of 100 NM x 200 NM at all times beginning after the 5th day (120 hours). To ensure a minimum of 40 active UUVs are on station at all times, we found that for a given set of conditions, 61 UUVs and

12 recharging stations must be inserted during the campaign and these must subsequently be augmented as the campaign progresses, due to wear out and failure. This is presented in Section 3.5.1.5 Modeling Results (without maintenance). Other assumptions/conditions require different numbers of UUVs and recharging stations to meet system requirements. This model allows SEA-8 to explore that trade-space.



**Figure 187: UUV Reliability States Diagram to Demonstrate How the UUVs Operate in the AO**

Second, the UUV system with maintenance was modeled. The UUV system with maintenance was still susceptible to wear out and failure. However, as shown in Figure 188, when the UUVs failed, they were recovered, repaired, and reinserted into the AOR. A minimum of 40 active UUVs were still required to be on station after the 5th day; but, under the same assumptions as the previous example, this can be achieved by deploying only 56 UUVs and 12 recharging stations, as presented in Section 3.5.1.7 Modeling Results (With Maintenance).



**Figure 188: UUV Reliability States with Recovery and Replacement. Note the Arrows Returning From the Damaged and Repair State to the Deploy and “Operation” States**

***D.1.1.1 Reliability States Diagram (Without Maintenance)***

Figure 187 is a simple state diagram showing how the UUVs were modeled to operate in the AOR in terms of movement between states. These states are described below. This top-level view of the reliability model is implemented using the EXTEND Modeling Software.

D.1.1.1.1 START. For modeling purposes, all UUVs and recharging stations were generated in the “Start” state. This is equivalent to all UUVs for deployment being inventoried at a maintenance depot and the operational equivalent for the “Start” state is the assignment of assets to the operation.

D.1.1.1.2 DEPLOY. UUVs enter the SoS in the “Deploy” state. In this state, the UUVs are deployed according to the ASWC deployment plan. From this state, UUVs may also transition to the “Damaged” state as a result of manufacture error, damage caused by water impact, and environmental hazards as described in Section 3.5.1.1.3.2, Mean Time Between Failures.

D.1.1.1.3 OPERATE. All operational UUVs search the AOR. As previously mentioned, a minimum number of 40 operating UUVs are required to be



actively searching an area of 100 NM x 200 NM at all times beginning after the 5th day (120 hours). UUVs that are damaged during operation move to the “Damaged” state. All UUVs have an assumed battery life of 80 hours<sup>316</sup> requiring undamaged UUVs to visit the “Recharge” state multiple times during the operation.

D.1.1.1.4 RECHARGE. Successfully recharged UUVs return to the “Operation” state. UUVs that fail during recharge move to the “Damaged” state.

D.1.1.1.5 DAMAGED. If the UUV fails in the “no maintenance” model, it is lost and will exit the model. The UUV will not be recovered for further operational use.

### ***D.1.2.1 Reliability States Diagram (With Maintenance)***

The reliability states diagram is the same for the states diagram without maintenance, but with additional transitions related to a new state: “Damaged and Repair,” as seen in Figure 189. Other variables and assumptions remain unchanged.

D.1.2.1.1 DAMAGED AND REPAIR. In the previous model, all UUVs were unrecoverable. Hence, many UUVs would be lost and fall out of the AOR during the operation. The lack of repair required seven deployments to deliver a total of 84 UUVs and 12 recharging stations into the AOR.

This section discusses a model that allows for the recovery of UUVs in the AOR, either after the UUV has completed its mission or when the UUV needs to be recovered for maintenance. The UUV will enter the “Damaged and Repair” state. After the UUV is repaired it will return to the “Operation” state.

### ***D.1.3.1 Modeling Parameters***

D.1.3.1.1 BATTERY LIFE. Maximum battery life is set to be 80 hours for a UUV.<sup>317</sup> A UUV’s battery lifetime consists of a fixed operating time and a variable transit time to and from the recharging station. This parameter could be varied in follow-on studies as battery technology advances.

D.1.3.1.2 CORRECTIVE MAINTENANCE TIME TO REPAIR. Once maintenance-capable assets are available, units that fail can be recovered,

---

<sup>316</sup> *The Navy Unmanned Undersea Vehicle (UUV) Master Plan*, 9 November 2004, p. 67.

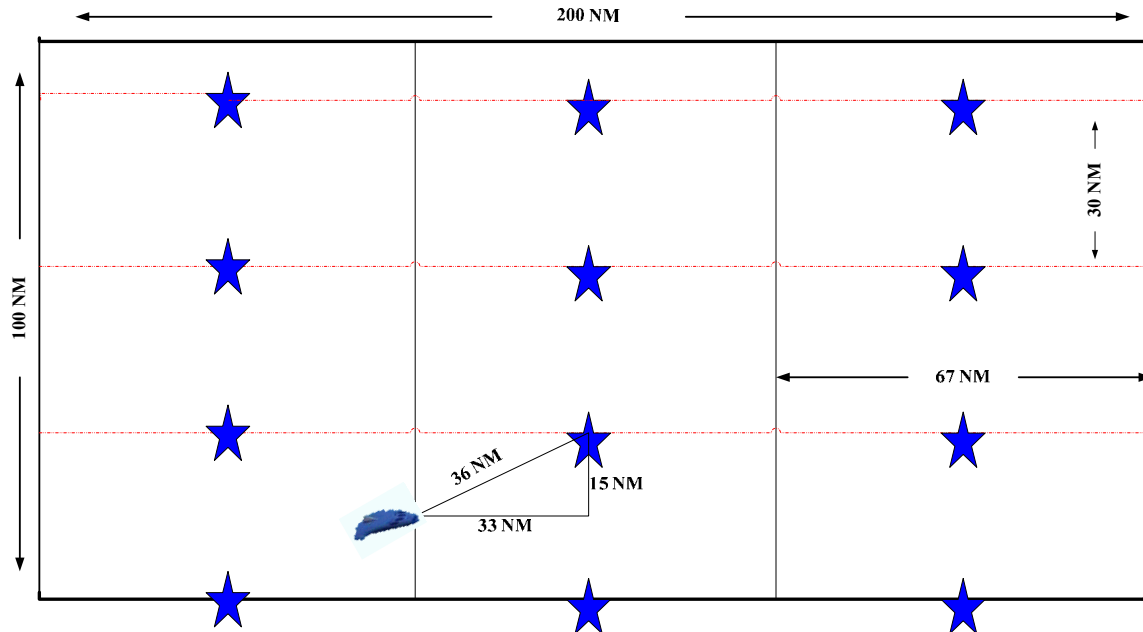
<sup>317</sup> *The Navy Unmanned Undersea Vehicle (UUV) Master Plan*, 9 November 2004, p. 67.

repaired, and returned to the AOR. Turnaround time data is not available for a UUV being repaired onboard a ship. Time to repair and return the UUV to the AOR was assumed based on estimates made by analogy with existing systems and operational experience to help SEA-8 to determine this parameter. This variable may not hold true when the actual UUV becomes available. However, this variable provides useful insight into the requirements that may be on a UUV.

D.1.3.1.3 RECOVER. Maintenance assets will arrive by the end of the 5th day (120 hours). Once assets (surface and subsurface) are on station, they will be available to recover UUVs for maintenance. The model assumes that the time lapsed from recovery to return to AOR is a normal distribution, with a mean of 12 hours and a standard deviation of 3 hours is accurately portrayed.

#### ***D.1.4.1 Modeling Variables***

D.1.4.1.1 NUMBER OF RECHARGING STATIONS. In the AOR, the 12 recharging stations, each with one recharging bay, will be deployed evenly so that the longest trip any UUV will have to make will be approximately 36 NM. Sensitivity analysis will show the effects of altering the number of recharging bays in the AOR from 12 to 60 recharging bays. The current assumption is that every recharging station has the same number of recharging bays; therefore, the number of recharging bays can only increase by a factor of 12. To increase the amount of UUVs able to be recharged, 12 additional recharging bays will have to be added (one bay per station). SEA-8 understands that Figure 189 does not represent the optimal geometry for UUV recharging stations. Other geometries may improve the recharging bay utilization and limit the UUV transit distance to the recharging bay.



**Figure 189: 100 NM x 200 NM Area of Responsibility (AOR) with 12 Recharging Stations. This illustrates that the farthest distance a UUV will have to travel is 36 NM assuming that the UUV always seeks the nearest recharging bay**

D.1.4.1.2 OPERATING TIME (OPTIME). UUV operating time before recharge, *OpTime*, plus the transit time to the recharging station and return to the operating area was modeled utilizing the lognormal distribution with a mean of 6 hours and a standard deviation of 3 hours, based on the assumption that the UUV seeking recharge will transit to the nearest recharging bay and queue if necessary. The UUV will search for and track enemy submarines for a certain amount of time before seeking a recharging station. Sensitivity analysis will show the effects of varying that operating time before recharge from 20 hours to 70 hours.

D.1.4.1.3 NUMBER OF UUVS DEPLOYED. For the War of Machines alternative, all UUVs are air-deployed. The number of UUVs deployed is limited by the amount of assets available to deploy the UUVs. Each mission dispatched to deploy UUVs to the AOR is limited to 35 UUVs. This restriction is due to the size and weight of deploying assets as mentioned in Section 3.4.2.3.1 Deploy Assets.

### ***D.1.5.1 Modeling Assumptions***

D.1.5.1.1 TIME TO RECHARGE UUV BATTERY. At a seminar in the SEA lecture series, representatives of General Atomics spoke of the advances in battery technology. After meeting with engineers from General Atomics,

SEA-8 found that it will take 20% of the expended life to fully recharge a UUV's battery (e.g., 40 hours expended will require 8 hours to recharge).<sup>318</sup> Sensitivity analysis could be conducted to explore the effects of varying the 20% recharge rate/time.

## **BATTERY RECHARGE TECHNOLOGY**

It seems counterintuitive that a battery can recharge faster than the operating life. Stating that batteries can be recharged at 20% the rate they were discharged is true (even currently) under some circumstances. Battery charge and discharge rates are commonly referred to in terms of a C rate. Charging or discharging a battery fully in 1 hour would be referred to as 1C. This means that for a 20Ahour cell, discharging at 1C implies drawing a 20A current for 1 hour. If you only drew 10A, the cell would last 2 hours and you would be discharging at  $C/2$ . If the cell could handle it and you exhausted all of the energy by drawing 80A for 15 minutes, this would be 4C. The maximum C rate for battery charge and discharge are dependent on the battery chemistry as well as how the cells were manufactured (e.g., thicker electrodes allow higher current draw). In general, the maximum C rate for charge and discharge are the same (although this is not always true, it holds as a general rule). Normally, in UUV batteries one discharges considerably slower than 1C. For example, if you have a 3kWh battery pack (e.g., Bluefin BPAUV) that runs at 32V nominally, about 93Ah are available. Since this is normally expended over a 20 hour mission, the discharge rate (assuming you surface with your batteries completely drained) is about 5A or  $C/20$ . Most batteries (including the Li-polymers used in the Bluefin and many other vehicles) will easily handle recharge at  $C/4$ , and sometimes even at C or 2C if you can deal with a somewhat shorter battery pack life. Since you discharged at  $C/20$  and charged at  $C/4$  (a 4-hour charge cycle), you would, indeed, be getting a recharge time of 20% of the discharge time. On the other hand, if you discharged the 3kWh pack at its maximum no-damage rate (which is about C for Li-polymers) of 93A for 1 hour, it would be impossible to charge in 20% the time, since

---

<sup>318</sup> Richard Thome, Director, Advanced Programs Electromagnetic Systems Division, General Atomics Co., San Diego, CA. Lecture provided to SEA 8 (Naval Postgraduate School, Monterey, CA), 18 August 2005.

you would need to slam the pack with 465A to charge in 12 minutes (20% of 1 hour). At 465A, the pack would fail catastrophically.<sup>319</sup>

#### D.1.5.1.2 MEAN TIME BETWEEN FAILURES (MTBF).

Modeling the failure rates of a system that is in the process of initial Developmental and Operational testing is complicated, as there is little data available on which to base assumptions and/or estimates.

The final model utilizes failure rates in several states:

- “Deploy” State
- “Operation” State
- “Recharge” State

“Deploy” state addressed infant mortality with a 4% probability of failure during deployment (96% Reliability) for air-inserted UUVs, based on the similarly sized and deployed JSOW.<sup>320</sup> To be conservative, the same probability of failure is assumed regardless of insertion method.

In the “Operation” and “Recharge” states possible failures include, but are not limited to, battery failure, corrosion, electronic malfunction, collision, countermeasures, and guidance components. Because of the lack of data available, this model randomly assigns failures to each UUV as it transverses between these two states. The random failures were assigned according to a Weibull distribution.

$$h(t) = \frac{\beta}{\eta} \left( \frac{t}{\eta} \right)^{\beta-1}$$

**Equation 14: Hazard Function**

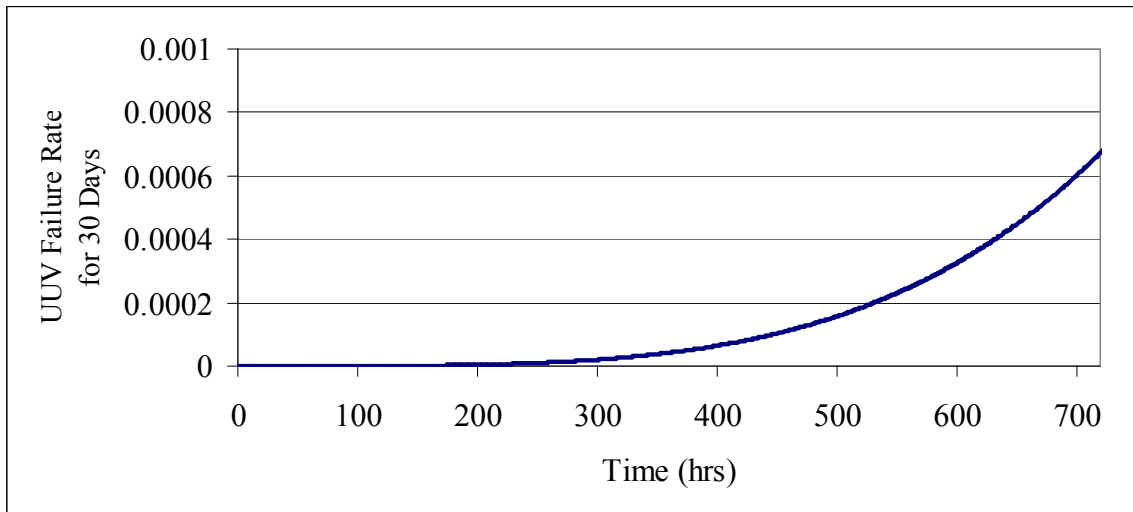
The Weibull distribution is a common distribution for modeling failure rates. For example, assuming a shape parameter ( $\beta$ ) of 5 and a scale parameter ( $\eta$ ) of 1,150 hours results in a mean UUV lifetime of 44.0 days and a standard deviation of

---

<sup>319</sup> Corey Jaskolski, President Hydro Technologies, interviewed by LT Joseph A. Gueary (Naval Postgraduate School, Monterey, CA), 22 November 2005.

<sup>320</sup> “AGM-154 Joint Standoff Weapon [JSOW],” Federation of American Scientists, [www.fas.org/man/dod-101/sws/smart/agm-154.htm](http://www.fas.org/man/dod-101/sws/smart/agm-154.htm).

10.1 days. Under these assumptions, Figure 190 shows the resulting UUV failure rate after the UUVs have been deployed.<sup>321</sup>



**Figure 190: UUV Failure Rate After UUVs Have Been Deployed**

D.1.5.1.3 PROBABILITY THAT RECHARGING STATION FAILS. Recharging stations will not fail for this model.

D.1.5.1.4 UUV TRANSIT ON DEPLOYMENT. It is assumed that the UUVs are deployed with a guidance package capable of placing the UUV within two hours transit of its assigned sector.

D.1.5.1.5 UUV RECHARGE BAY QUEUING STANDBY MODE. If a UUV seeking an open recharging bay is required to queue, the UUV will bottom, hibernate, and stand-by until a recharging bay becomes available. This is accomplished in the model by not having the UUVs age in the recharge queue.

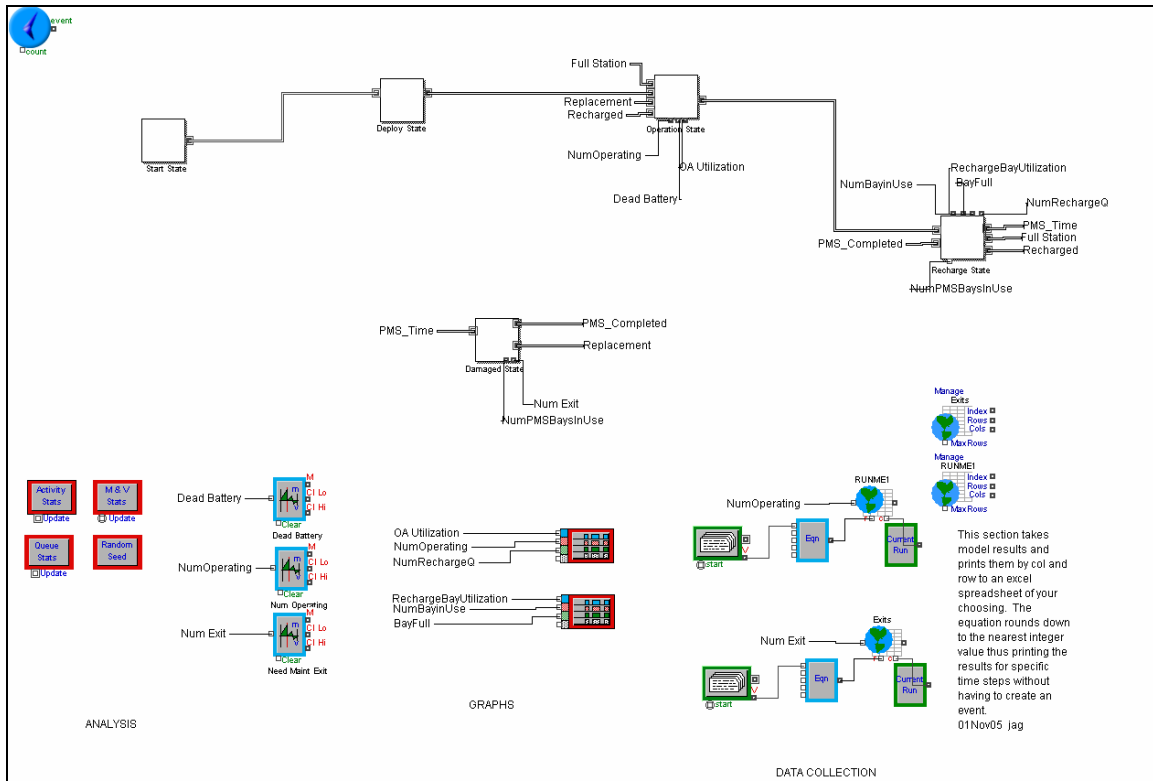
### ***D.1.6.1 EXTEND Modeling***

Modeling began with an outline of what the model needs to represent, which was introduced in Section 3.5.1.1 Reliability States Diagram (Without Maintenance) and Section 3.5.1.2 Reliability States Diagram (With Maintenance). Those states, as illustrated in Figure 191, are used to describe how the EXTEND software was manipulated to become the chosen model for this reliability study. The basic model was

---

<sup>321</sup> Failure rate is the probability a UUV fails in the next interval of time given that it has survived until some particular time, divided by the time interval.

created with the ability to adapt between the “with maintenance” and the “without maintenance” capabilities.



**Figure 191: Overview of EXTEND Model Displaying States as Hierarchical Blocks**

This model utilizes a variable, OpTime (Section 3.5.1.4.2), which is the time during a recharging cycle that the UUVs will seek an open recharging bay. OpTime is held constant for all UUVs generated. Later model versions explore, for work load balancing, randomizing OpTime for all UUVs at generation and then making OpTime constant after the first recharge.

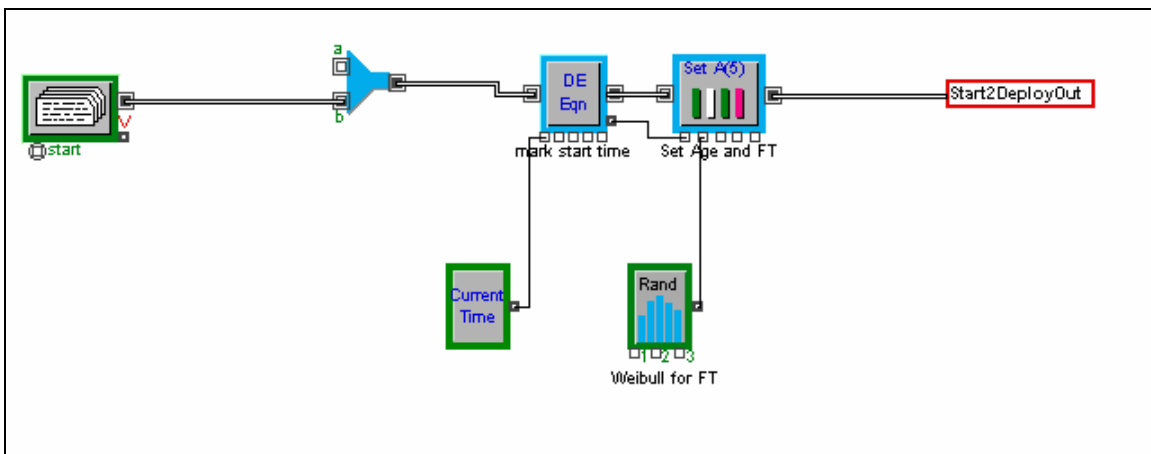
**D.1.6.1.1 START TO DEPLOYMENT STATE.** The model begins with a Program Block that generates objects at specified time intervals. Each object is tagged with the following attributes:

- Failure Time (FT) – Stores randomly produced UUV time of failure (hours)
- Age – Stores the computed age of the UUV (hours)
- Initial – Sets whether the UUV has been to the Recharge Bay or not (binary, 0, 1)
- NStart\_Time – The completion time of the last recharge (hours)

- NumRecharge – Number of times the UUV has been recharged (integer)
- Start\_Time – Start time during initial operations used if UUVs deployed sequentially instead of simultaneously (hours)
- OpTime – Number of hours the UUV will operate until seeking recharge (hours)

All attributes are initialized to zero at generation.

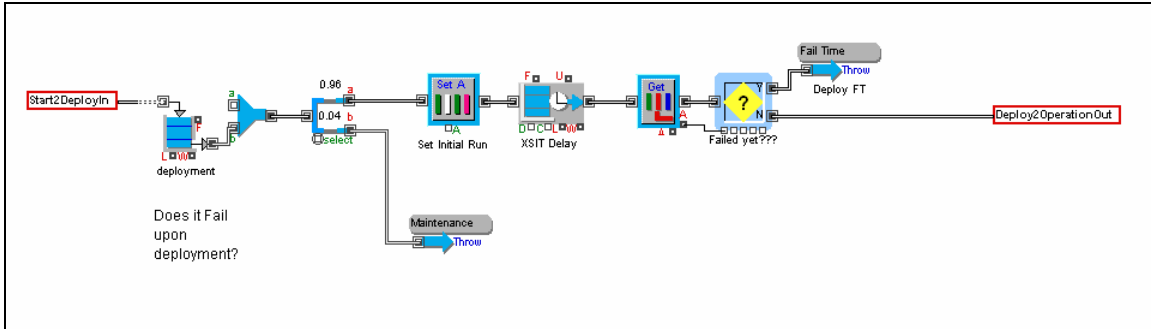
Once generated, each UUV is assigned a random failure time based on the Weibull distribution, and then Age is set equal to current model time. This happens in what the Reliability Modeling Team labeled the “Start” state (see Figure 191).



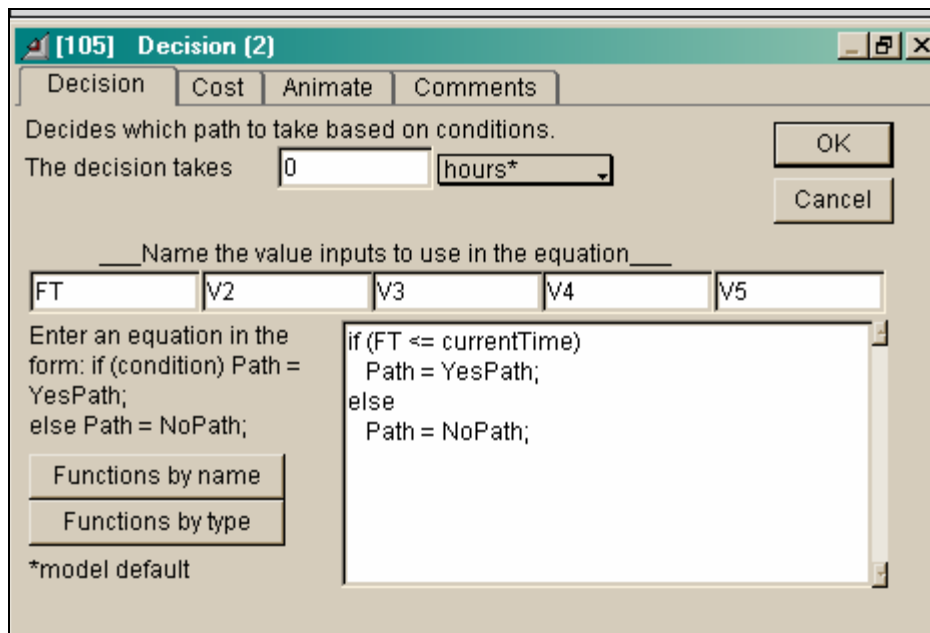
**Figure 192: EXTEND Model Showing the “Start” State**

The Deployment state, as seen in Figure 193, takes the UUV and performs two distinct functions. First, it deploys the UUVs with a probability of failure of 4% as stated in Section 3.5.1.5.2, Mean Time Between Failures. UUVs that fail are moved to the “Damaged” or “Damaged and Repair” state and those that do not fail continue to the “Operation” state. Second, it compares UUV FT to the current model time. If the FT is less than or equal to the current model time, the UUV is moved to the “Damaged” or “Damaged and Repair” state. In the “Damaged” or “Damaged and Repair” state, if allowed and if assets are available, the failed UUVs are repaired. The comparison occurs in what is called a Decision (2) block shown in Figure 194.





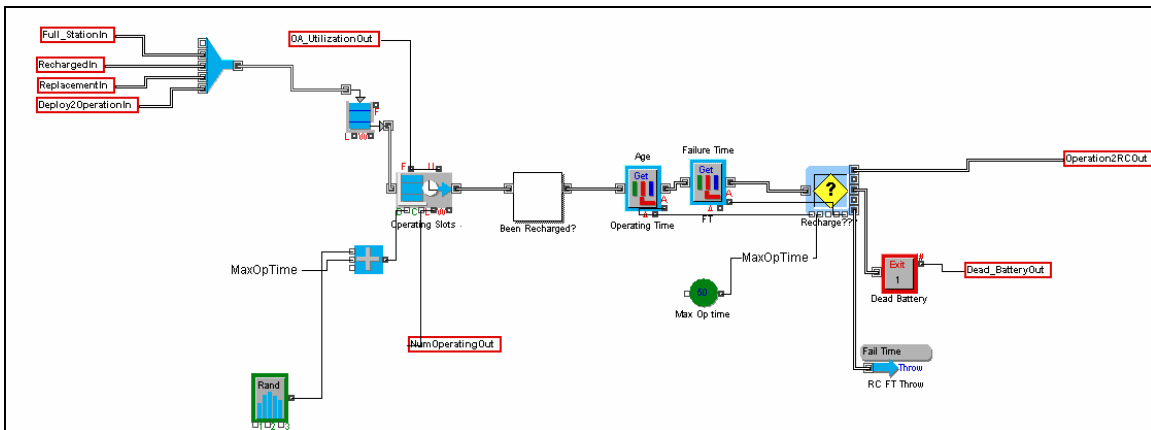
**Figure 193: EXTEND Model Showing the “Deploy” State**



**Figure 194: Example Decision (2) Block**

D.1.6.1.2 DEPLOY TO “OPERATION” STATE. The “Operation” state takes the UUVs and passes them to an Activity Delay block that takes the UUVs and ages them by the sum of OpTime variable and the random transit time to and from the recharging station. The transit time is initially modeled using a random lognormal distribution with mean 6 hours and a standard deviation of 3 hours. This is the modeler’s first attempt at varying the times of the UUVs as they operate and recharge. As you can see in Figure 195, the “Operation” state takes UUVs from various output paths throughout the model. Those paths are listed and defined below.

- Path 1
  - Once deployed, UUVs move from the “Deployment” state to the “Operation” state
- Path 2
  - Full Station - If queuing for recharging stations is not enabled, then the UUVs will not proceed to the “Recharge” state unless there is an open recharging bay. Instead of queuing, UUVs return to the “Operation” state (higher risk of dead battery). By not enabling recharging station queues, UUVs are returned to the AO without recharging. Because of this, there is a higher risk of the UUVs operating until their battery life expires
- Path 3
  - Recharged – After being recharged, the UUV returns to the “Operation” state
- Path 4
  - Replacement – If repair and replacement is allowed, the UUV will return to the “Operation” state after being repaired



**Figure 5: EXTEND Snapshot Displaying the “Operation” State**

D.1.6.1.3 OPERATION TO “RECHARGE” STATE. Once the UUVs have exited the operating area block, its age must be determined, which will be used in the decision block that determines if the UUVs have operated/aged enough to

move on to the “Recharge” state. This particular Decision (5) block utilizes four of the five output paths.

- Path 1
  - Sends the UUVs to the next Decision block if the UUVs have aged sufficiently, but are not more than its battery life
- Path 2
  - UUVs exit the model if their time since recharge is greater than battery life
- Path 3
  - If the UUVs’ FT, set in “Start” state, exceeds current model time, then failed UUVs move to the “Damaged” state

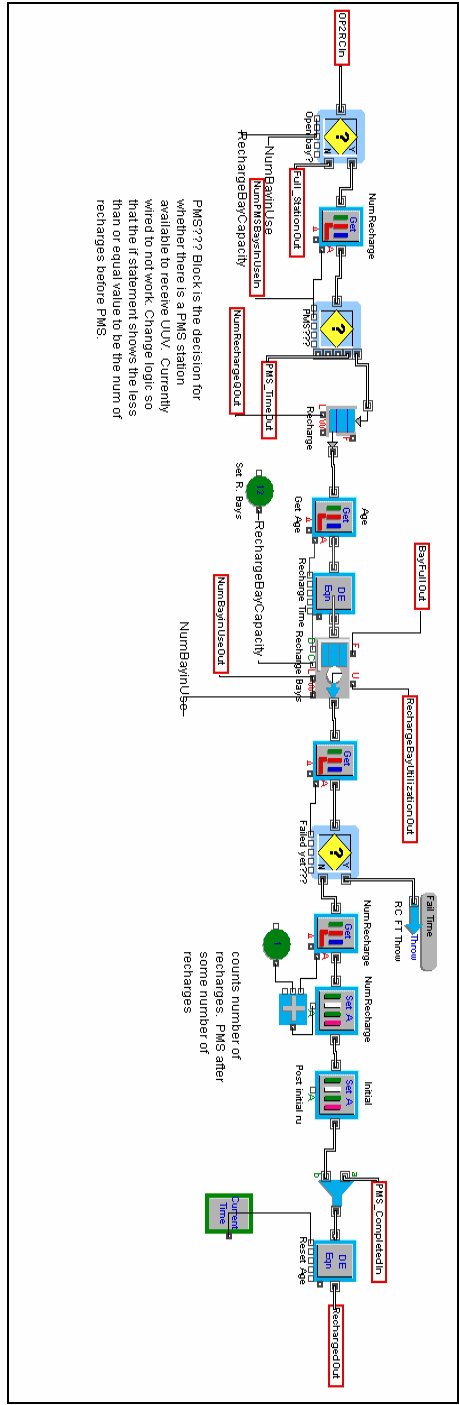
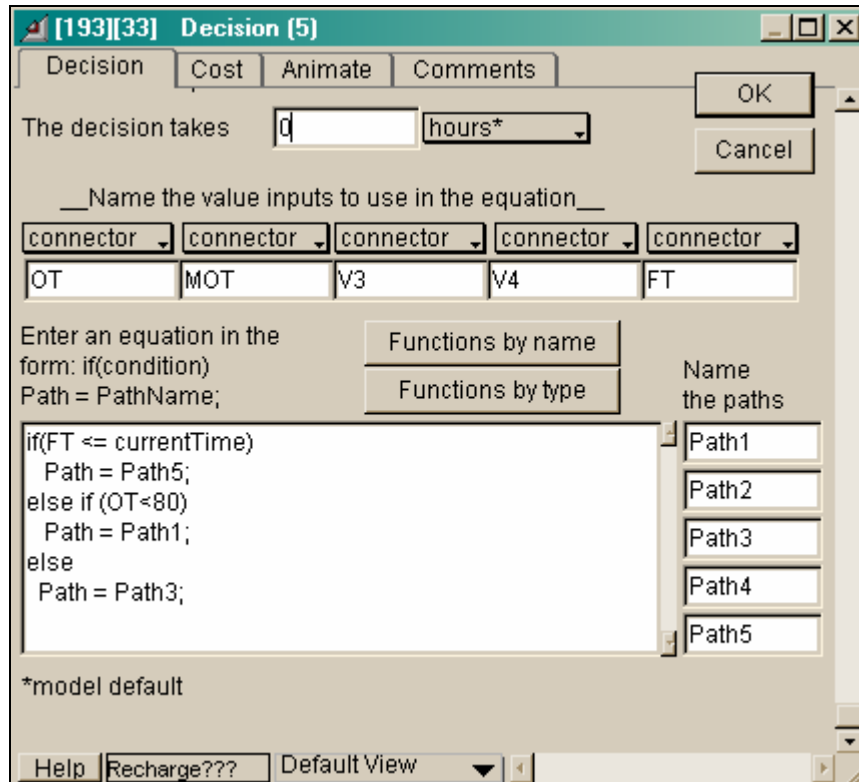


Figure 196: EXTEND Snapshot Showing the Operation and “Recharge” States



**Figure 197: EXTEND Decision (5) Block Showing Logic to Determine if UUV Has Failed**

The model includes a number of capabilities that, for the purpose of this study, have been configured to be inactive. Those inactive capabilities include the following:

- Function to eliminate recharging station queues by assuming that the UUVs are capable of sensing whether there is an open recharging bay at the nearest recharging station. If there are no open/available bays, the UUV keeps operating. The biggest negative for this function is an increase in UUVs that are lost due to dead battery
- Function to conduct preventive maintenance on UUVs at some set interval. It was assumed that with the short duration of the 30-day mission, UUVs would not require PMS

The UUVs continue through the model to the recharging bays, which are represented by another Activity Delay block labeled Recharge Bays, where two things occur. First the length of the delay for each UUV is calculated by taking 20% of the UUVs' time since last recharge. Secondly, the capacity of the Activity Delay is set

by altering the *Number of Recharge Bays* variable in the notebook. Following the Recharge Bays, the UUVs' FTs are checked. Those that have not failed continue on, where the variable *NumRecharge* is increased by one, the variable *Initial* is set to false, and the Age of the UUVs is reset to the equivalent of 0. Finally, the recharged UUVs are sent back to the "Operation" state by way of the variable *Recharged*.

#### D.1.6.1.4 "DAMAGED"/"DAMAGED AND REPAIR" STATE.

UUVs can move into the "Damaged"/"Damaged and Repair" state from the "Deploy," "Operation," and "Recharge" states. The UUVs arrive in the "Damaged" state through either deployment failure or failures throughout the UUVs' life. Once an asset capable of depot-level repairs is available, all damaged UUVs can be repaired or replaced depending on the theatre commander's orders. Figure 198 shows the three available options for damaged UUVs. The three damaged options are deployment damage, failure, and preventive maintenance system (PMS). In the base model, the PMS option is not functioning and the failure option is set for the no maintenance simulation run. This means that when the UUVs fail, they exit the system instead of being repaired and reinserted into the "Operation" state.

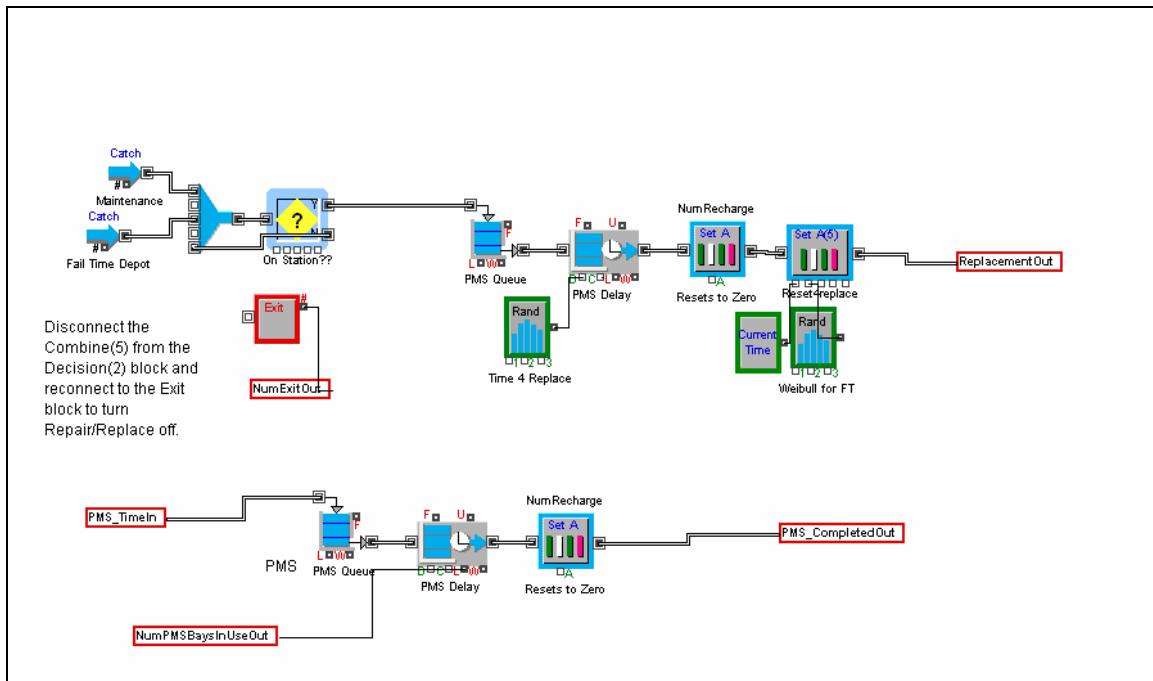
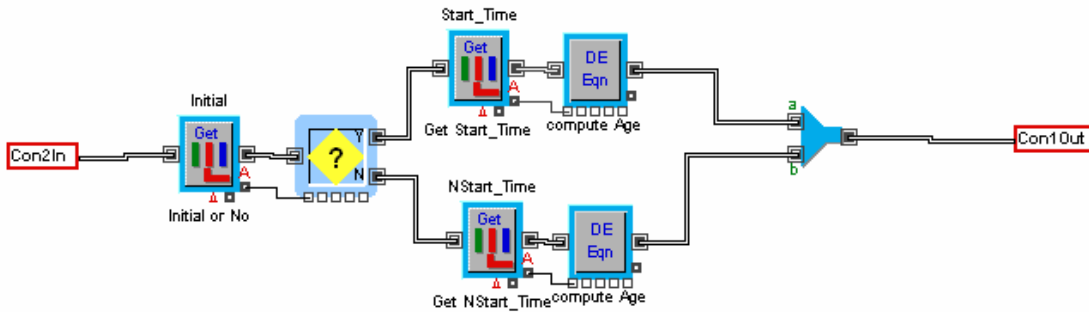


Figure 198: EXTEND Model Snapshot Displaying the "Damaged" State

D.1.6.1.5 AGE. As shown in Figure 199, Age is calculated in two separate lines or sections of code.



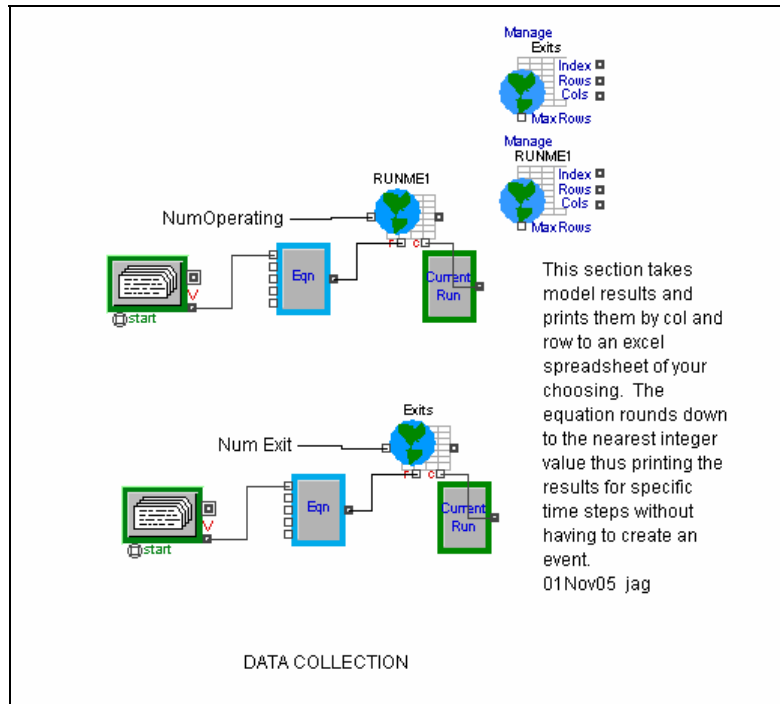
**Figure 199: EXTEND Model Snapshot Displaying the Age Block From the “Operation” State**

In the initial cycle, or time in the model before the first recharge, age calculation was accomplished by simply setting *Age* equal to current model time. For each subsequent run, the *Age* calculation was a little more complex. After recharging, but before returning to the “Operation” state, each UUVs’ age is set equal to the current model time. Inside the “Operation” state, where *Age* is determined/set for post-initial UUVs, the current model time and UUVs’ age are compared and then the difference is set as that UUVs’ new *Age*.

D.1.6.1.6 DATA COLLECTION. The metric for this study is to minimize the number of operating UUVs, while maintaining 40 operating UUVs in the AOR over the time span from the end of the 5th day until the end of the 30th day (see Equation 14).

For this study the modelers needed a method to capture the number of UUVs operating over time for the various simulations run. As seen in Figure 200, the Global Array block was used to collect the data that was recorded in the variable *NumOperating* and store it in a new array that could be exported to an Excel workbook. The Global Array, as shown above, records the value of *NumOperating* hourly. The rate, or point, at which the Global Array records the value of *NumOperating*, depends on how the equation and start blocks are used and the settings within the Global Array block. For an hourly reading, the start block was configured to push an object every hour. This caused the equation block to send an output to the Global Array block, therefore

recording the inputted value, *NumOperating*, in the appropriate row. The same process was used to record the number of UUVs that exited the system due to post-deployment failure.



**Figure 200: EXTEND Model Snapshot Displaying the Data Collection Section of the Model**

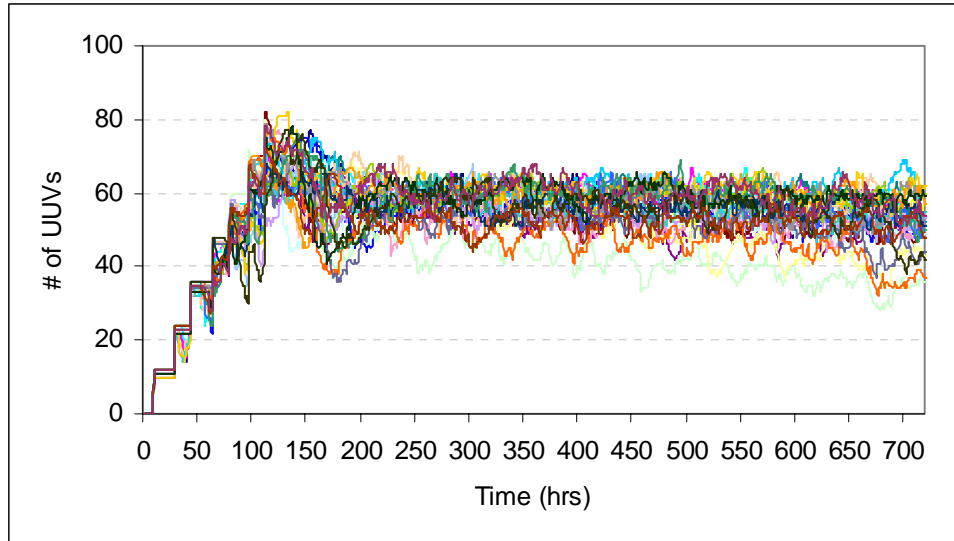
#### ***D.1.7.1 Modeling Results (Without Maintenance)***

Since no maintenance was allowed, it was assumed that more UUVs will be needed for a 30-day campaign to meet the minimum operating number of 40 UUVs than the with maintenance option. In the top right corner of Figure 197, is the UUV deployment plan, which is required in order to provide the ASWC with a high probability of 40 UUVs actively operating in the AOR between the 5th and 30th day.

In particular, the number and pattern of UUVs in the initial insertion and subsequent augmentations were set such that more than 90% of all simulations had 40 or more UUVs active in the AOR at all times after the 5th day of the operation. That is, a simulated UUV deployment was judged successful if it maintained 40 or more UUVs in the AOR. Acceptable UUV insertion and augmentation schemes had to achieve a simulation success rate of better than 90%, with 95% confidence. Among the acceptable schemes, this one minimized the total number of UUVs and recharging stations required.



In Figure 201, the output from simulations is shown.

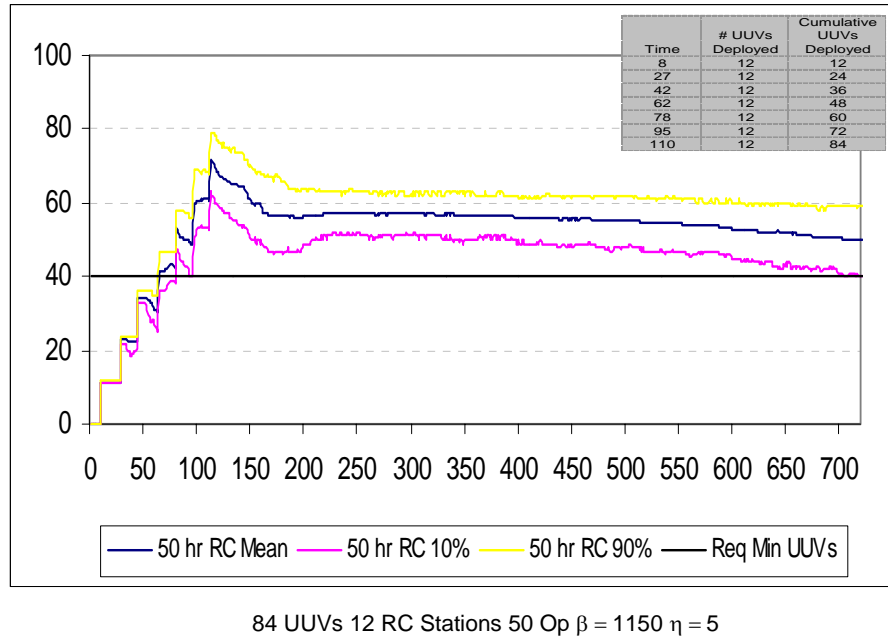


**Figure 201: Output From Simulations Showing the Number of Operating UUVs in AOR Over Time**

Each line represents the number of operating UUVs in the AOR for one simulation from hour 0 to 720. A number of interesting features are visible. Starting from the left:

- The pattern of insertions for the first 120 hours shows that the number of UUVs rapidly climbs to approximately between 58 and 61 UUVs. However, it also shows there is some variability due to infant mortality.
- From hour 150 to about 175, the number of UUVs noticeably declines as the UUVs leave the AOR to transit to the recharging stations. Given 12 recharging stations, the UUVs then queue up and sequentially enter the recharging stations and return to the AOR
- From hour 175 to 650, the system settles into steady state with about 60 UUVs operating in the AOR at any given time
- Note that in some simulations the number of UUVs falls off and then recover. This is because in that particular simulation, a number of UUVs coincidentally required recharging. (As previously mentioned, the deployment plan was designed so that there would be a high probability that less than 10% of all simulations would drop below 40 UUVs.)

The table in the top right corner of Figure 202 is a visual representation of the UUV Deployment Plan of the with maintenance model, in contrast to the without maintenance model.



**Figure 202: Mean Number of UUVs and Percentiles for 256 Simulations at Each Hour**

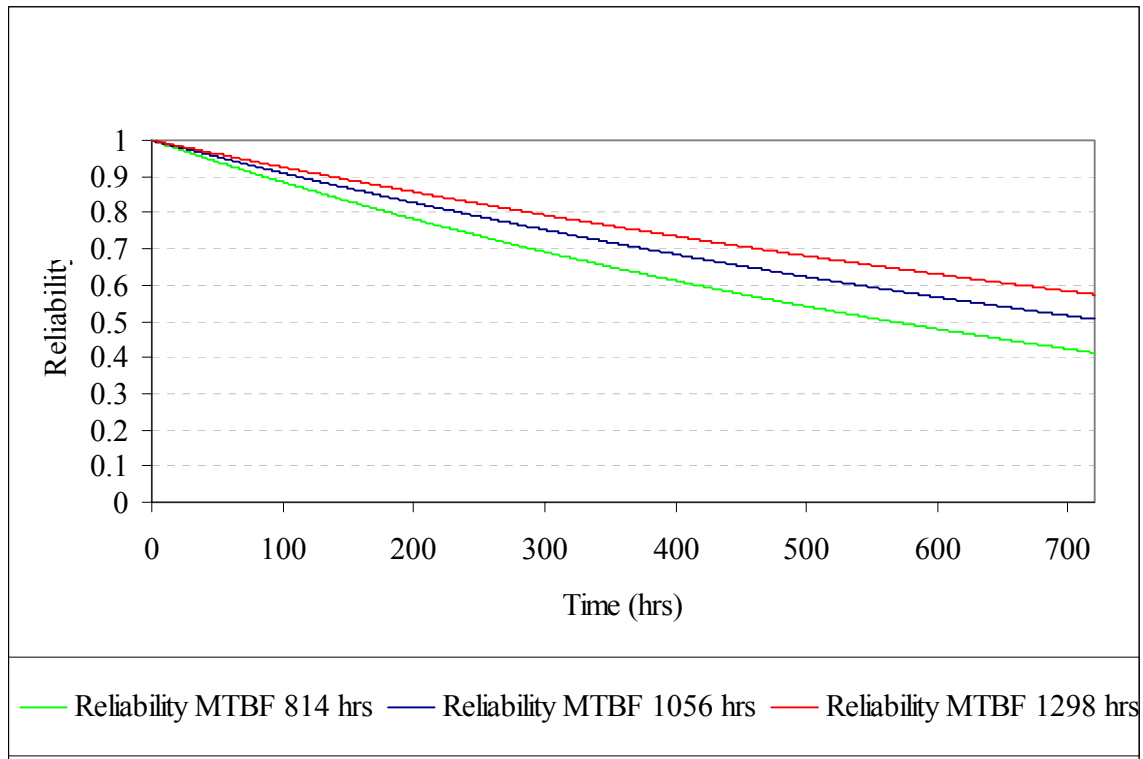
Figure 202 shows the mean number of UUVs and percentiles for the 256 simulations at each hour. While from the end of the 5th day onward, the mean number of UUVs is generally at or above 50 UUVs, Figure 202 shows that the 10th percentile of the number of UUVs approaches the minimum of 40 UUVs. Figure 202 also shows that a higher mean number of UUVs is necessary to offset the variability resulting from failures later in the deployment period, in order to ensure most deployments will have 40 or more operating UUVs at all times.

$$R(t) = e^{-\left(\frac{t}{MTBF}\right)}$$

**Equation 15**

From Section 3.5.1.5.2 Mean Time Between Failures (MTBF), the expected amount of hours before a UUV fails was 44.0 days, with a standard deviation of 10.1 days. Reliability of the UUVs can be determined as time progresses using the

Mean Time Between Failure and  $\beta = 1,150$ . Figure 203, using Equation 17 for individual system reliability, demonstrates how an individual UUV will begin to wear out as the mission progresses. After the ASWC deploys 84 UUVs at 720 hours, the estimated UUV reliability is approximately 0.91 as per Equation 16.



**Figure 203: Reliability of an Individual UUV**

$$R(t)_s = 1 - (1 - R(t)_1)(1 - R(t)_2)(1 - R(t)_3) \dots (1 - R(t)_k)$$

**Equation 16**

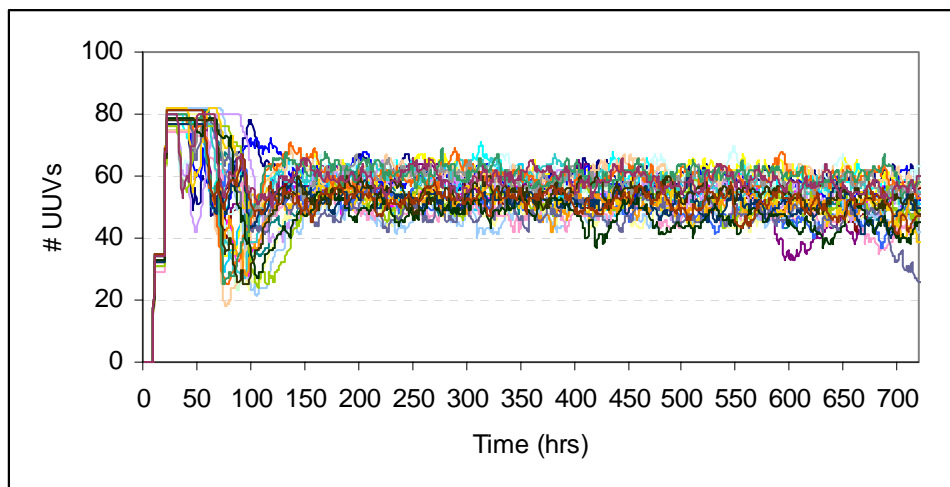
Alternative 3: War of Machines is a series system. Everything from the B-52s to the system of UUVs will have to work together in order for this alternative to work. Referring to Sections 3.4.2.3.2.1 Deploy Assets (Mission Reliability of the B-52 is 0.85), 3.4.2.3.2.1 Sensor Reliability (Infant Mortality of the UUVs is 0.96), 3.5.1.5.2 Mean Time Between Failures (MTBF) (Reliability of UUVs is 0.91), and previously determined reliabilities are used to calculate the overall reliability of the subsystem reliabilities.

### ***D.1.8.1 Modeling Result (With Maintenance)***

If the ASWC decides to recover and repair UUVs in the AOR, the ASWC would only need to deploy a total of 56 UUVs. This deployment plan would maintain the minimum number of 40 UUVs in the AO.

The table in the top right-hand corner of Figure 198 is a visual representation of the UUV Deployment Plan of the with maintenance model in contrast to the without maintenance model.

In Figure 204, the output from simulations with maintenance is now shown.

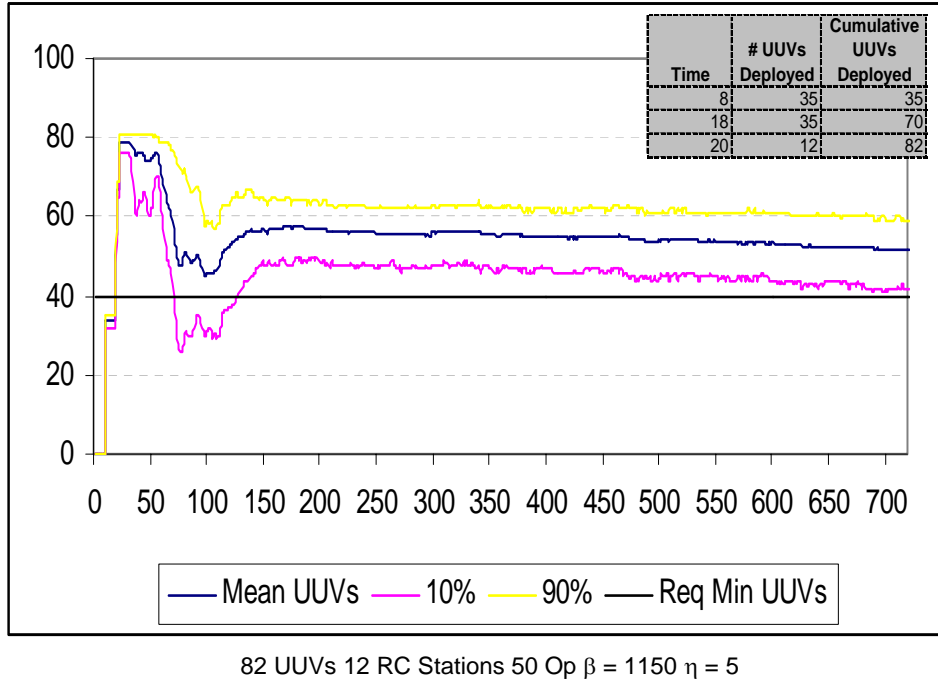


**Figure 204: Output from Simulations Where Maintenance was Allowed Showing Number of Operating UUVs in AOR Over Time**

In Figure 204, the output from simulations with maintenance is shown. Each line represents the number of operating UUVs in the AOR for one simulation from hour 0 to 720. Similar to the simulations without maintenance, the pattern of insertions for the first 20 hours shows that the number of UUVs rapidly climbs to approximately 56 UUVs. As before, it shows there is some variability due to infant mortality, and a significant drop off as they all tend to transit to recharging stations simultaneously. Much like the previous simulations without maintenance, these simulations with maintenance do show a noticeable cycle after the 5th day.

Figure 198 shows the mean number of UUVs and percentiles for the 256 simulations with maintenance at each hour. While from the end of the 5th day

onward, the mean number of UUVs is approximately around 55 UUVs to 41 UUVs; Figure 204 shows that the 10th percentile of number of UUVs eventually approaches the minimum of 40 UUVs.



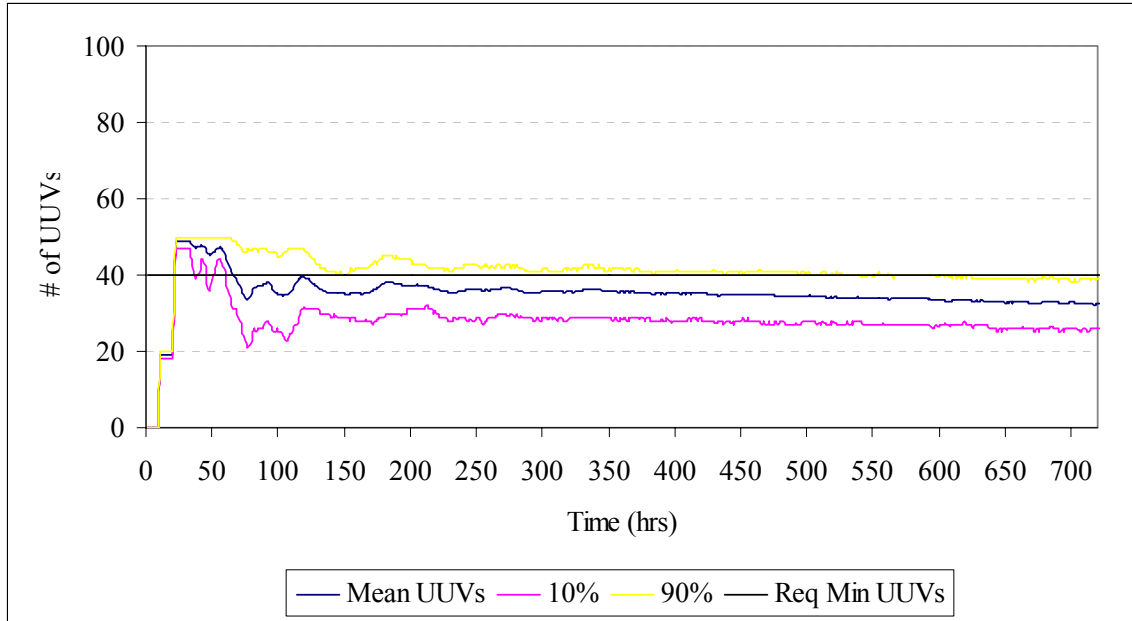
**Figure 204: Mean Number of UUVs and Percentiles for 256 Simulations Where Maintenance Was Allowed at Each Hour**

The reliability of the with maintenance model is similar, with the exception of the reliability of the maintenance platforms. Including the reliability of 0.95 for the SSGN (from Section 3.4.2.3.1 Deploy Assets) to Equation 14 provides a reliability of 0.83 for the 30-day mission.

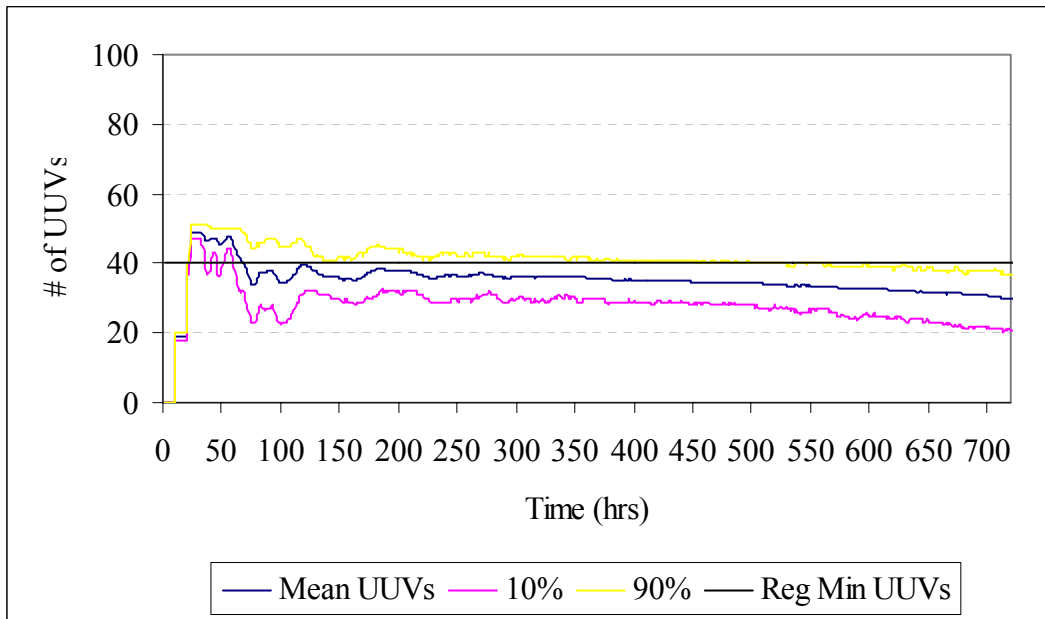
#### ***D.1.9.1 Sensitivity Analysis***

Sensitivity analysis was conducted to determine the level of impact that specific variables had on the War of Machines alternative. Based on NSS modeling, oceanographic conditions, and the projected performance of future sensors, SEA-8 originally felt that 51 UUVs and 12 recharging stations, with the deployment plan presented in Table 23, would be needed in order to maintain 40 UUVs in the AO. After extensive modeling using EXTEND simulation software presented in Section 3.5.1.6 EXTEND Modeling, SEA-8 found that 51 UUVs, with the deployment plan presented in

Table 23, would not provide the ASWC enough coverage for the AOR for either the maintenance capable or the nonmaintenance-capable option as seen in Figure 205 and Figure 206.



**Figure 205: Number of Available UUVs With Maintenance Option**



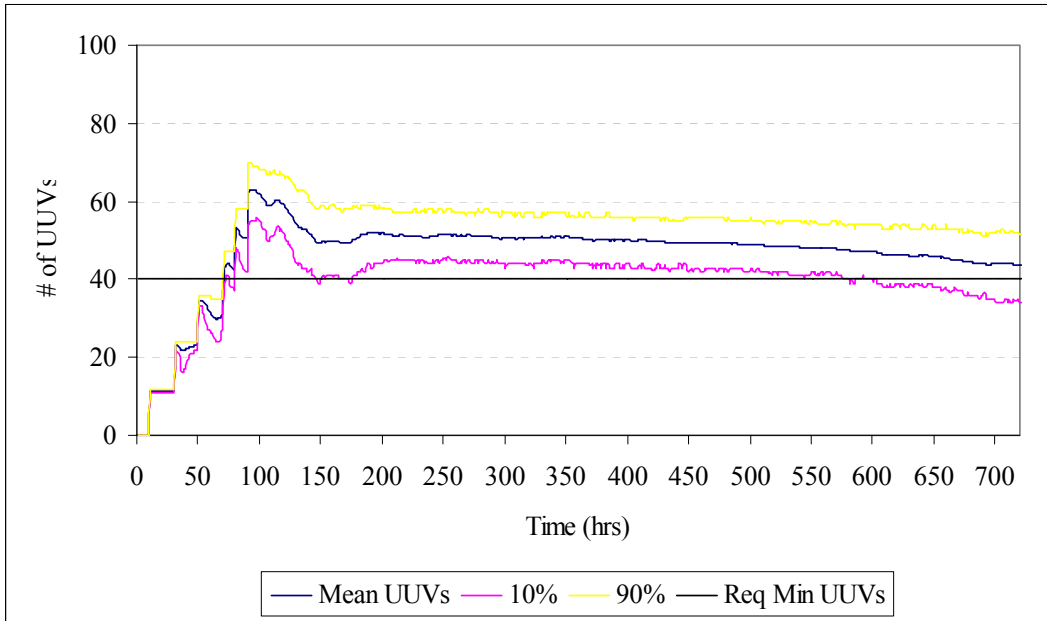
**Figure 206: Number of UUVs Without Maintenance Option**

<b>Time (hours)</b>	<b># UUVs Deployed</b>	<b>Cumulative UUVs Deployed</b>
8	20	20
18	20	40
20	11	51

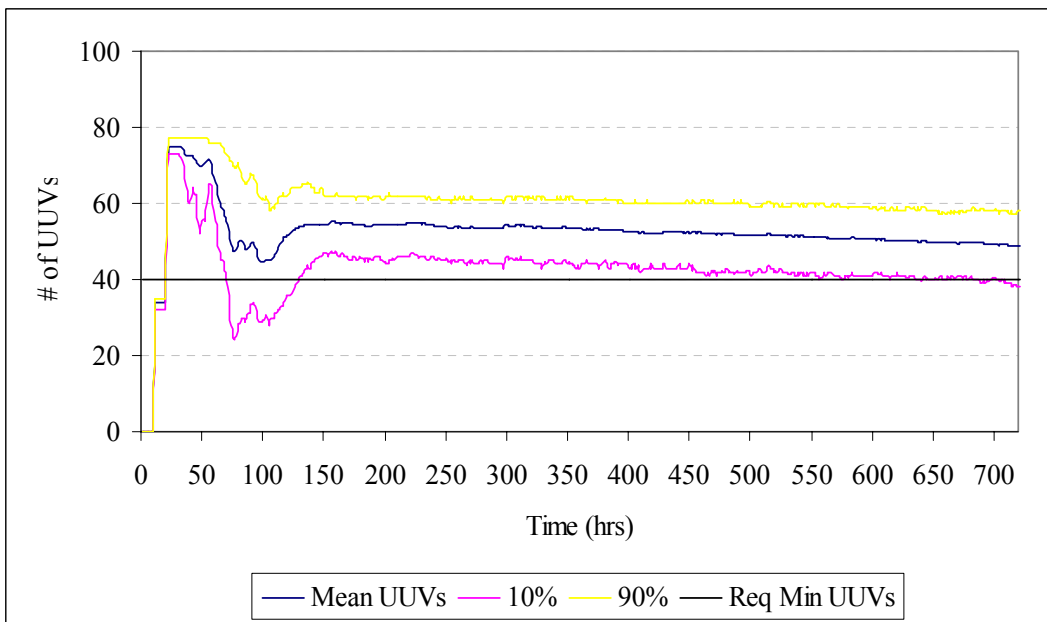
**Table 23: Deployment Plan for 51 UUVs With and Without Maintenance Option**

In both cases, the UUVs were deployed according to the deployment plan in Table 1. As per Figures 205 and 206, the infant mortality of the UUVs contributed to the loss of some UUVs on deployment, but of the 51 UUVs deployed only two UUVs were lost due to infant mortality demonstrated by the mean UUV. Before the 75th hour, some UUVs exited the system due to the UUV's need to recharge after 50 hours of *OpTime*. Before the sudden drop-off, only 49 UUVs are operating in the AOR. After the sudden drop-off, 35 UUVs were operating in the AOR, which indicates that 14 UUVs were unable to recharge because the recharging bays were occupied by other UUVs. Once the UUVs have finished recharging and begin to operate in the AOR, the slow decline of UUVs overtime is indicative of the Weibull function with a  $\beta = 5$  (shape) and  $\eta = 1,150$  (scale).

In order to improve on the availability of UUVs in the AOR, SEA-8 implemented the deployment plan in Table 24, which increased the number of UUVs deployed, changed the times to deploy the UUVs, added 12 additional recharging bays (24 total), increased the *OpTime* from 50 hours to 60 hours, and improved on the reliability of the UUVs by increasing  $\eta$  to 1,250. The results are noted in Figures 206 and 207. Here it can be seen that more UUVs are available from the end of the 5th day until the end of the 30th day even though the requirement of 40 UUVs is not met until after the 130th hour.



**Figure 206: Number of UUVs Available Without Maintenance Option**



**Figure 207: Number of UUVs Available With Maintenance Option**

Time (hours)	# UUVs Deployed	Cumulative UUVs Deployed
28	35	35
48	35	70

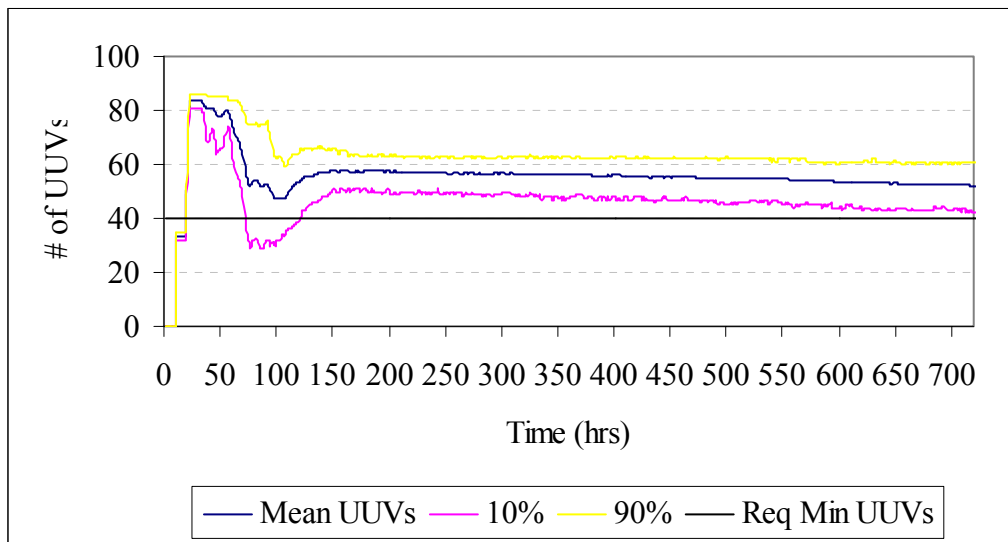
**Table 24: Deployment Plan for 70 UUVs With and Without Maintenance Option**



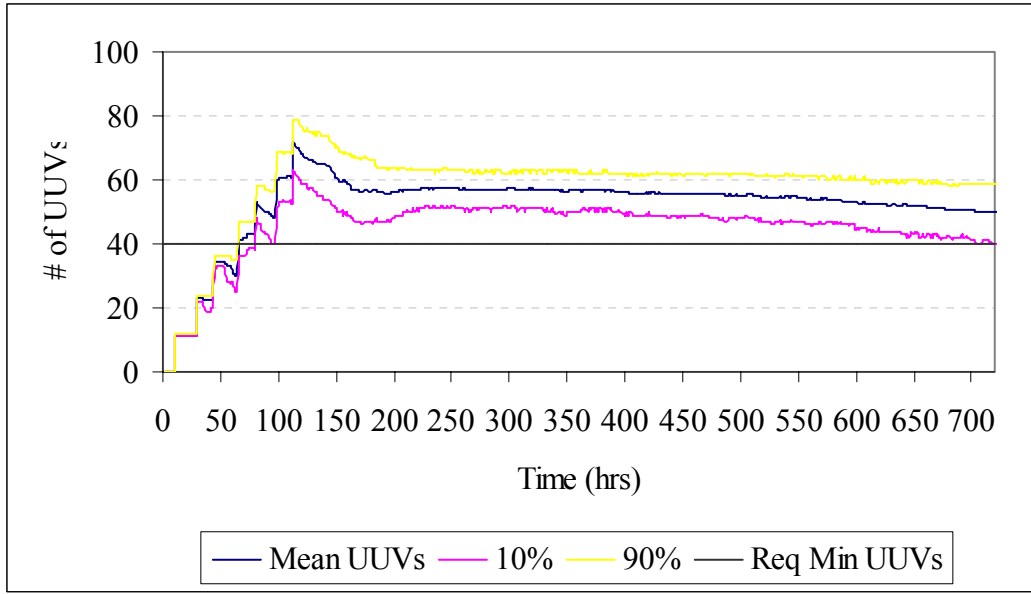
In order to better utilize recharging bays, SEA-8 increased the number of UUVs operating in the AOR and decreased the number of UUVs queuing for a recharging bay. This was accomplished with a new deployment plan, shown in Table 25. The new deployment strategy of more UUVs in smaller numbers, at random intervals, ranging from 15 to 20 hours apart allows for more efficient utilization of the recharging bays. It is important to note that with this deployment plan gridlock at the recharging bay still occurs. However, this deployment plan provides less loss of UUVs because of a dead battery than previously explored options. It is important to recall that SEA-8 developed this deployment plan based on our requirements of 40 UUVs available after the 5th day until the end of the 30th day.

Time (hours)	# UUVs Deployed	Cumulative UUVs Deployed
8	12	12
27	12	24
42	12	36
62	12	48
78	12	60
95	12	72
110	12	84

**Table 25: Deployment Plan With 84 UUVs, 12 Recharging Stations, and 50 Operating Hours**



**Figure 208: 82 UUVs Deployed With Maintenance Option**



**Figure 209: 84 UUVs Deployed Without Maintenance Option**

SEA-8 felt that the “maintenance” option would out perform the “no maintenance” option. The results of several trials show that the difference is very small for the period of time being studied. The data presented in Sections 3.5.1.7 and 3.5.1.8 show that the “with maintenance” option only reduced the number of UUVs required by two UUVs. SEA-8 feels that this is an important point for decision makers to consider as UUVs are designed and built. The “maintenance” option leads to an additional monetary cost to upgrade platforms for maintenance of UUVs and train sailors to maintain these UUVs. However, the “no maintenance” option alleviates the ASWC of the burden of losing a ship while recovering a UUV for only two additional UUVs.

Some important takeaways to note during sensitivity analysis are that tactics outweigh technology. The method of deployment variable had the largest effect on UUV availability. An example of this is the deployment of 70 UUVs in two groups of 35. The simulation proved this to be an unrealistic plan of deployment. Spreading the deployment out over time prevented the recharging stations from being overcrowded and allowed more UUVs to search the AOR for enemy submarines. Secondly, SEA-8 learned that changes in the number of recharging stations and OpTime created very small changes in the number of UUVs in the AOR. Lastly, for short time periods, large increases in UUV reliability had very little, if any, effect on the availability of the UUVs.

The bottom line is simple. For a mission of such brevity as the one studied, almost all the studied variables are nonfactors in improving availability. For this mission scenario and architecture, the reliability of the individual UUVs, the number of recharging bays, and the length of operating time before recharge, all proved not to be major factors in the overall system of UUV availability. In order to cause a noticeable and favorable difference in the system of UUV availability, new tactics and/or policies should be explored. System availability studies manipulate the trade space so that the customer is able to make a more informed decision regarding the requirements of a system. As was learned in this study, the trade space boundaries can be highly influenced by nonmaterial issues. The Joint Capability Integration and Development System (JCIDS) process groups these nonmaterial considerations into the Doctrine, Organization, Training, Material, Leadership, Personnel, and Facilities (DOTMPLF) category. The DOTMPLF category deals with all things not technical in nature. For example, in this availability study, the tactics used to employ the UUVs would fall into this category, but the battery technology, recharging stations, communications, etc., would not.

DOTMPLF, or policy, decisions can be made to make up for or improve on immature technology, as is the case in this study. Throughout this appendix, there are figures that meet the requirement, but do so at the expense of deploying more UUVs. Figures illustrated earlier in this section are all examples of how decisions can cause the unnecessary loss of UUVs. A smart deployment plan shows that with a minimal number of UUVs, the requirement can be met. After comparing contrasting deployment policy decisions, it is readily apparent that the policy implemented by the ASWC has an enormous effect on the number of UUVs required to deploy in order to meet the requirement.

## APPENDIX E



NAVAL  
POSTGRADUATE  
SCHOOL

Meyer Institute of Systems Engineering  
777 Dyer Road  
Monterey, CA 93943

January 10, 2006

Memorandum for SEA8 Students

Subject: Integrated Project Tasking Letter

1. This tasking letter provides a framework of guidance for the performance of the April-to-June planning process leading to your July-to-December integrated project.
2. Anti-Submarine Warfare in the Littorals in 2025 will present a major challenge for the United States. Quieter and more capable submarines operating in the littoral environments will continue to challenge the Navy as it assures access. The Navy is developing programs to assure the continued capability to establish undersea superiority.
3. The Navy published “Anti-Submarine Warfare, Concept of Operations for the 21<sup>st</sup> Century” on 20 Dec 2004. That CONOPS states that the Navy will meet the 21<sup>st</sup> Century ASW challenge through an integrated combat systems approach that can fully exploit all joint mobility, sensors, and weapons capabilities. This will require new systems that provide pervasive awareness, speed, persistence, and technological agility to eliminate or neutralize subsurface threats. There are numerous systems engineering issues about the development of such new systems. These issues include system architecture, system integration, risk (technical, schedule, cost, performance), and technological challenges.
4. Your task is to develop a system-of-systems (SoS) architecture for the conduct of undersea warfare in the littorals in the 2025 time frame. The Navy will focus on developing the following operations and associated capabilities (from the CONOPS document) to bring 21<sup>st</sup> Century ASW to fruition. Working with your project advisors (Project lead advisor: Dr. Shoup, Technical advisor: VADM (ret) Bacon, SEA team advisor: Dr. Vaidyanathan), you will select some or all of these capabilities for your system requirements.
  - a. Battlespace preparation and monitoring
  - b. Persistent detection and cueing
  - c. Combined arms prosecution
  - d. High volume search and kill rates
  - e. Non-traditional methods
  - f. Defense in-depth

5. You should consider both existing and proposed systems, and you should be prepared to design others to fill any capability gaps you discover.
6. Your role in the July-to-December project will be to serve as the lead systems engineering team, supported by other collaborative teams. You should employ the systems engineering methodology you have studied in your NPS course work. You should commence a Needs Analysis in the spring quarter to determine operational requirements for the system of systems; you should define the functions your SoS will perform and establish boundaries for it. (Some of this activity may extend into the summer quarter.)
7. You will have to define the selected concepts for supporting systems (which may be thought of as “components” in your SoS) and partition the overall SoS requirements to be addressed by collaborating teams. By the end of the spring quarter, you should develop a Problem Statement, Mission Statement and associated guidance documents. You should have a draft Project Management Plan by that time as well.
8. It will be your responsibility to identify supporting “teams” whose work you can integrate with yours in the performance of the project—you should be laying this groundwork during the planning phase ending in June. (Some collaborating “teams” may be individual researchers or thesis authors.) Information concerning some potential collaborating teams is provided in Appendix A to this memorandum. Your project advisors will assist you in coordinating with other student teams. Ultimately, it will be your responsibility to integrate the work of supporting teams.
9. You are expected to treat this project as your own. You will, to a large degree, need to identify for yourselves the tasks necessary to produce an excellent study. Your faculty advisors will, of course, participate in discussions with you, as appropriate, during this process. You are required to seek out other groups of students and/or faculty who can contribute to and support your work. (The study director will provide significant help in the areas addressed in Appendix A.) Your success will partly be determined by the breadth of the interdisciplinary team you assemble to work on this problem. You should be familiar with the integrated projects done by SEA classes who preceded you, particularly those portions of SEA 4 and SEA 5 reports dealing with anti-submarine and undersea warfare. In addition, you should familiarize yourself with Joint Task Force ASW initiatives and establish working ties with Fleet ASW Command.
10. Deliverables. For the planning phase (April-to-June) you should plan on delivering:
  - a) An informal IPR no later than 2 June 2005 at which you present your restated problem, your project management plan, and your across campus partners; coordinate with your Project Management course instructor.
  - b) A written Project Management Plan draft (by the end of the Spring quarter) which will be your guiding document (subject always to change

when appropriate) for the performance of the project in the July-to-December time frame.

- c) The ultimate deliverable (at the end of the project in December) will be a quality technical report and a formal briefing of the entire project, suitable for presentation to senior Navy and other visitors.

David H. Olwell, PhD  
Associate Director for Education

Appendix A: Other curricula on campus that may participate

- a. The Total Ship System Engineering curriculum
- b. The Undersea Warfare curriculum
- c. The Combat Systems curricula
- d. The Electrical and Computer Engineering curricula
- e. The Oceanography curriculum
- f. The Operations Analysis curricula
- g. The Space Systems curricula
- h. The Information Systems curricula
- i. The Electronic Warfare curricula
- j. The Business Management curricula

Appendix B: Terms of Reference (JP 1-02 as amended Nov 2004)

**Undersea Warfare** – Operations conducted to establish battlespace dominance in the underwater environment, which permits friendly forces to accomplish the full range of potential missions and denies an opposing force the effective use of underwater systems and weapons. It includes offensive and defensive submarine, antisubmarine, and mine warfare operations.

**Antisubmarine Warfare** – Operations conducted with the intention of denying the enemy the effective use of submarines. Also called ASW.

**Mine Warfare** – The strategic, operational, and tactical use of mines and mine countermeasures. Mine warfare is divided into two basic subdivisions: the laying of mines to degrade the enemy's capabilities to wage land, air, and maritime warfare; and the countering of enemy laid mines to permit friendly maneuver or use of selected land or sea areas. Also called MIW.

## APPENDIX F: CLASSIFICATION OF SUBMARINES

The following was downloaded from the <http://www.battlebelow.com/destroyer.htm> Website:

### CONTACT CLASSIFICATIONS

...in addition to a visual sighting, contacts [are] made with enemy submarines by either Sonar or radar. The likelihood that any of the three methods had been able to accurately identify or detect the presence of an enemy submarine in the area requires that the contact be initially categorized into one of four possible classifications. As the investigation proceeds, the contact classifications can be either upgraded or degraded as necessary.

- CERTSUB - (*certain submarine*) A contact has been sighted and positively identified as a submarine.
- PROBSUB - (*probable submarine*) A contact that displays strong evidence of being a submarine. This classification is normally based on the information gathered by either sonar or radar.
- POSSUB - The classification (*possible submarine*) is given to a contact on which available information indicates the likely presence of a submarine, however there is insufficient evidence to justify a higher classification. POSSUB is always followed by an assessment of the confidence level:

A. LOW CONFIDENCE: A contact that cannot be regarded as a non-submarine and which requires further investigation

B. HIGH CONFIDENCE: A contact which, from evidence available, is firmly believed to be a submarine but does not meet the criteria for PROBSUB.

NONSUB – This condition is indicated when a visual sighting or the sound/radar evaluation is satisfied that the contact is NOT a submarine.<sup>322</sup>

---

<sup>322</sup> “World War Two Anti-Submarine (ASW) Destroyer Tactics,” found at <http://www.battlebelow.com/destroyer.htm>, (accessed 13 June 2005).



## LIST OF REFERENCES

- Air Force Total Ownership Costs, O&S revised rates as of 21 September 2005, <https://aftoc.hill.af.mil/AFI65503/15-1/15-1Sep05.xls>, (accessed 1 November 2005).
- Antisubmarine Warfare Commander's (ASWC) Manual (NTTP 3-21.1) pp. 3-1 – 3-2.
- Australian Bureau of Meteorology, "Wind Speed and Direction Rose" for East Sale, LAT 38.11S LON 147.13E, [http://www.bom.gov.au/cgi-bin/climate/cgi\\_bin\\_scripts/windrose\\_selector.cgi](http://www.bom.gov.au/cgi-bin/climate/cgi_bin_scripts/windrose_selector.cgi), (accessed 15 Aug 2005).
- Australian Fisheries Management Authority, "Bass Strait Central Zone Scallop Fishery, Data Summary 2003," p. 14, [http://www.afma.gov.au/information/publications/fishery/data\\_summ/docs/bass\\_2003.pdf](http://www.afma.gov.au/information/publications/fishery/data_summ/docs/bass_2003.pdf), (accessed 15 Aug 2005).
- Benedict, Jr. John R. *Taking a Long-Term Perspective on U.S. Navy ASW Objectives, Capabilities & Trends*, 12 January 2004.
- Benedict, Jr. John R. "Future Undersea Warfare Prospectives," *John Hopkins Applied Physics Laboratory Technical Digest*, Volume 21 #2 (2000).
- Boeing Company "MMA Program," <http://www.boeing.com/defense-space/military/mma/flash.html>, (accessed 15 Jul 2005).
- Breemer, Jan S. *Anti-Submarine Warfare: A Strategy Primer*, Monterey, CA: Naval Postgraduate School, July 1988.
- Chief of Naval Operations, *Anti-Submarine Warfare, Concept of Operations*, 20 Dec 05.
- Clark, Vern, ADM, USN, *Sea Power 21: Projecting Decisive Joint Capabilities*, Navy Office of Information, Washington, DC, September 2002 (published in Proceedings, October 2002).
- College of Aerospace Doctrine, Research and Education. "Warfare Studies: Carrier Strike Group." *Warfighters Planning Course*. [http://www.cadre.maxwell.af.mil/warfaresudies/wpc/wpc\\_txt/navy/csg.htm](http://www.cadre.maxwell.af.mil/warfaresudies/wpc/wpc_txt/navy/csg.htm), (accessed 15 July 2005).
- College of Aerospace Doctrine, Research and Education. "Warfare Studies: Executive Strike Group." *Warfighters Planning Course*. [http://www.cadre.maxwell.af.mil/warfaresudies/wpc/wpc\\_txt/navy/esg.htm](http://www.cadre.maxwell.af.mil/warfaresudies/wpc/wpc_txt/navy/esg.htm), (accessed 15 July 2005).

- College of Aerospace Doctrine, Research and Education. "Warfare Studies: Navy Units." *Warfighters Planning Course*.  
[http://www.cadre.maxwell.af.mil/warfaresudies/wpc/wpc\\_txt/navy/units.htm](http://www.cadre.maxwell.af.mil/warfaresudies/wpc/wpc_txt/navy/units.htm), (accessed 15 July 2005).
- Cote, Owen R. Jr., *The Third Battle*, Newport, RI: Naval War College.
- Coupland, Richard L. *Theater ASW Experiment 2004 Lessons Learned*, Naval Sea Systems Command, 19 July 2005.
- Daniel Nussbaum. "OA4702 - Cost Estimation," Naval Postgraduate School, Monterey, CA, 20 September 2005.
- Daniel, Donald C. *Anti-Submarine Warfare and Superpower Strategic Stability*, University of Illinois Press, 1986.
- Defense Acquisition Acronyms and Terms*, Eleventh Edition, September 2003.
- Defense Industry Daily, "The Fire Scout VTUAV Program: By Land and Sea (updated)," [http://www.defenseindustrydaily.com/2005/10/the-fire-scout-vtuav-program-by-land-and-by-sea-updated/index.php#orison\\_mc](http://www.defenseindustrydaily.com/2005/10/the-fire-scout-vtuav-program-by-land-and-by-sea-updated/index.php#orison_mc), (accessed 9 November 2005).
- DeMartino, David. Chief Engineer at Naval Surface Warfare Center. Panama City, FL. (Unpublished cost data for Sea Predator), 2 November 2005.
- Department of the Navy, Chief of Naval Operations Office, *Request for Approval of Proposed Navy Training Systems Plan (NTSP) for the Navy Consolidated Sonobuoys N88-NTSP-A-50-9910C/A*, 11 August 2000.  
[http://www.globalsecurity.org/military/library/policy/navy/ntsp/Sonobuoys\\_a.pdf](http://www.globalsecurity.org/military/library/policy/navy/ntsp/Sonobuoys_a.pdf), (accessed 8 November 2005).
- DePoy, Phil. "From Research to Reality: A Retrospective on the Development and Acquisition of Naval Capabilities During the Cold War Era" (Transcript, Jul 27, 2005), pp. 104-105.
- Edmonds, Martin. "Anti-Submarine Warfare: New Scenarios." 2000. <http://www.global-defence.com/2000/pages/antisub.html>, (accessed 3 August 2005).
- Eisner, Howard. *Essentials of Project and Systems Engineering Management*, Wiley Publishing, 2002.
- Ellis, Jerry W. G., RADM, USN (Ret). "Naval Oceanography, -A Submarine Force Multiplier." *Undersea Warfare*. 1 No. 4 (Summer 1999).  
[http://www.chinfo.navy.mil/navpalib/cno/n87/usw/issue\\_4/ naval\\_ocean.html](http://www.chinfo.navy.mil/navpalib/cno/n87/usw/issue_4/ naval_ocean.html), (accessed 13 October 2005).

- Federation of American Scientists. "AGM-154 Joint Standoff Weapon [JSOW]." <http://www.fas.org/man/dod-101/sws/smart/agm-154.htm>, (accessed 17 September 2005).
- Ferla, Carlo M. and Finn B. Jenses, "Are Current Environmental Databases Adequate for Sonar Predictions in Shallow Water," *SACLANT Undersea Research Center*, 2002.
- Freedom of American Scientists. "US Navy Ships." *Surface Warfare* <http://www.fas.org/man/dod-101/sys/ship/surface.htm>, (accessed 3 August 2005).
- Gardner, W. J. R. *Anti-Submarine Warfare*, London: Brassey's, 1996.
- Hall, Jason. "Total Ship Systems Engineering (TSSE) SEA TENTACLE," (initial draft, unpublished report), 19 November 2005.
- Hauser, Crystal. Northrop Grumman Corporation "DD(X)-avg.-annual-metric-cost" stated as \$40,0786,678 in TY02\$(Nov 17, 20050, converted to FY05\$ using Naval Cost Analysis Division SCN indexes of FY06-version 2.
- Hewish, Mark. "No Hiding Place: Undersea Networks Help Flush Out Littoral Targets." *Jane's International Defense Review*. 14 May 2004. <http://www4.janes.com/K2/>, (accessed 8 November 2005).
- Hill, J. R., Read Admiral, USN, *Anti-Submarine Warfare*, Naval Institute Press, Maryland, 1985.
- Holland, William J., RADM, USN, (Ret). "Offensive ASW –The Right Answer for the New Age," *The Submarine Review*, January 2005.
- Holland, William J., RADM, USN, (Ret). "The Navy is Hauling More Than Marines," *Proceedings*, May 2004.
- Jane's Underwater Warfare Systems* (London, England: Jane's Information Group, 10 June 2005).
- Jensen, F.B. and N.G. Pace, *Impact of Littoral Environmental Variability on Acoustic Predictions and Sonar Performance*. Kluwer Academic Publishers. 2002.
- Jordan, Wesley E. "Moving Forward in ASW," *Sea Technology* 38, No. 1 (January 1997): pp. 53-56.
- L-3 Ocean Systems [Internet, WWW], L-3 Communications, 15825 Roxford Street, Sylmar, CA 91342; [http://www.l-3com.com/os/airborne\\_13f.html](http://www.l-3com.com/os/airborne_13f.html).
- Lepage, Kevin D. "Modeling Propagation and Reverberation Sensitivity to Oceanographic and Seabed Variability," *SACLANT Undersea Research Center*, 2002.

Littoral Anti-submarine Warfare Concept, Naval Doctrine Command, 1 May 1998.

Martin, David L., Ph.D., CAPT, USN (Ret.) *NPS Menneken Lecture Series* “Persistent Littoral Undersea Surveillance: The Role of Undersea Gliders,” Applied Physics Laboratory, University of Washington, 6 October 2005.

METRON Incorporated, Naval Simulation System Analyst Guide, 31 August 2002.

Moore, Charles Jr., VADM, USN. “Sea Basing, Operational Independence for a New Century,” *Proceedings*, January 2003.

Morgan, John, VADM, USN. “Anti-Submarine Warfare: A Phoenix for the Future,” 1998. Article downloaded from <http://www.chinfo.navy.mil/navpalib/cno/n87/usw/autumn98/anti.htm> (accessed 5 July 2005).

Natter, Robert J., ADM, USN. “Sea Power 21 Series Part VIII: Sea Trial: Enabler of a Transformed Fleet.” *Proceedings* (November 2003), <http://www.usni.org/proceedings/articles03/pronatter11-2.htm> (accessed 22 July 2005).

Naval Doctrine Command, *Littoral Anti-Submarine Warfare Concept*, 1 May 1998.

Naval Postgraduate School, Meyer Institute of Systems Engineering, (unpublished memorandum: 28 March 2005).

Naval Sea Systems Command, Crane. “Background of Air ASW Sensors.” *Sonobuoys Home Page*. <http://sonobuoy.crane.navy.mil/SENSORS.HTM>, (accessed 3 November 2005).

Naval Transformational Roadmap, [www.chinfo.navy.mil/navpalib/transformation/trans-pg19.htm](http://www.chinfo.navy.mil/navpalib/transformation/trans-pg19.htm)

Navy Visibility and Management of Operating and Support Costs (VAMOSOC), SH-60 O&S data accumulated for FY2004, <http://www.navyvamosc.com/>, (accessed 7 November 2005).

Navy Visibility and Management of Operating and Support Costs (VAMOSOC), SSGN O&S data accumulated for FY2004, <http://www.navyvamosc.com/>, (accessed 7 November 2005).

Navy Visibility and Management of Operating and Support Costs (VAMOSOC), FFG O&S data accumulated for FY2004, <http://www.navyvamosc.com/>, (accessed 7 November 2005).

Navy Visibility and Management of Operating and Support Costs (VAMOSOC), SSN O&S data accumulated for FY2004, <http://www.navyvamosc.com/>, (accessed 7 November 2005).

Nielsen, Peter L., Martin Siderius, and Jurgen Sellschopp, “Broadband Acoustic Signal Variability in Two ‘Typical’ Shallow-Water Regions,” *SACLANT Undersea Research Center*, 2002.

- Patton, James A. Jr., CAPT, USN (Ret). "ASW is Back", *Proceedings*, February 2004.
- Van Alt, Christopher J. Woods Hole Oceanographic Institute (WHOI), 2 November 2005.
- Haas, Richard. Systems Engineer at Planning Systems, based on an unsolicited bid to SOCOM for StarLite, 3 November 2005.
- Porter, M.B. et al. High-Frequency Propagation for Acoustic Communications.
- Potter, John R. "Challenges of Seeing Underwater –A Vision for Tomorrow," Acoustic Research Laboratory, Electrical Engineering Department and Tropical Marine Science Institute, National University of Singapore, <http://arl.nus.edu.sg> (accessed 16 September 2005).
- Paulo, Gene. Systems Engineering and Architecture, Naval Postgraduate School, February 2005.
- Program Executive Office Integrated Warfare Strategies 5 (PEO IWS 5), *21<sup>st</sup> Century ASW MASTER PLAN*, 21 December 2004.
- Ragsdale, Cliff T. Spreadsheet Modeling and Decision Analysis, South-Western College Publishing, OH, 2001.
- Rudko, David D. *Logistical Analysis of the Littoral Combat Ship*, Monterey, CA: Naval Postgraduate School, March 2003.
- Sage, Andrew R. and James E. Armstrong. Introduction to Systems Engineering, New York: John Wiley & Sons, Inc., 2000.
- SPAWAR Technical Database, Unmanned Surface Vehicles, SPARTAN, <http://robot.spawar.navy.mil/home.asp?item=details&order=&sort=&page=1&cat=plat&sub=USV&id=35>, (accessed 19 November 2005).
- Systems Engineering and Architecture 4001 Class Notes (Naval Postgraduate School, 2005)
- Forecast International. *The Market for Airborne ASW Sensors*, 2004.
- Toti, Bill, CAPT, USN. *Full Spectrum ASW Campaign Plan*. Norfolk: Fleet ASW Command, 2004.
- Turgut, et al., "Measurements of Bottom Variability During SWAT New Jersey Shelf Experiments," *Office of Naval Research, Naval Research Laboratory*, 2002.
- United States Department of Defense, Contracts, Defense Logistics Agency, <http://www.defenselink.mil/contracts/2004/ct20040302.html>, (accessed Nov 18, 2005).
- United States General Accounting Office, Defense Acquisitions: *Evaluation of Navy's Anti-Submarine Warfare Assessment*, July 1999.

- United States General Accounting Office, Defense Acquisitions: *Evaluation of Navy's Anti-Submarine Warfare Assessment*, July 1999.
- United States General Accounting Office, *Evaluation of Navy's Anti-Submarine Warfare Assessment*, July 1999.
- United States National Military Strategy 2004*.
- United States Navy, *The Navy Unmanned Undersea Vehicle (UUV) Master Plan*, November 9, 2004.
- United States Navy. *Antisubmarine Warfare Commander's (ASWC) Manual*. NTTP 3-21.1.
- Urick, Robert. *Principles of Undersea Sound 3<sup>rd</sup> Edition*. McGraw-Hill, Inc., 1996.
- US Department of Transportation. "The Changing Face of Transportation: Chapter 1: Visions Past and Future." *Bureau of Transportation*.  
[http://www.bts.gov/publications/the\\_changing\\_face\\_of\\_transportation/chapter\\_01.html](http://www.bts.gov/publications/the_changing_face_of_transportation/chapter_01.html),  
(accessed 18 November 2005).
- US Department of Transportation. "The Changing Face of Transportation: Chapter 1: Visions Past and Future." *Bureau of Transportation*.  
[http://www.bts.gov/publications/the\\_changing\\_face\\_of\\_transportation/chapter\\_01.html](http://www.bts.gov/publications/the_changing_face_of_transportation/chapter_01.html),  
(accessed 18 November 2005).
- US Department of the Navy, *The Navy Unmanned Undersea Vehicle (UUV) Master Plan*, 9 November 2004.
- US Department of the Navy. *The Navy Unmanned Undersea Vehicle (UUV) Master Plan*. 9 November 2004.
- Waite, A.D. *SONAR for Practicing Engineers*. Thompson Marconi Sonar Ltd., 1998.

## INITIAL DISTRIBUTION LIST

1. Research Office (Code 09).....1  
Naval Postgraduate School  
Monterey, CA 93943-5000
2. Dudley Knox Library (Code 013).....2  
Naval Postgraduate School  
Monterey, CA 93943-5002
3. Defense Technical Information Center.....2  
8725 John J. Kingman Rd., STE 0944  
Ft. Belvoir, VA 22060-6218
4. Admiral Roger Bacon, USN (ret.) .....1  
Chair and Professor, USW  
Director of USW Research  
Bullard Hall, Room 115  
Naval Postgraduate School  
Monterey, CA 93943
5. Dr. Frank Shoup.....3  
Director, Research  
Wayne E. Meyer Institute  
Bullard Hall, Room 108A  
Naval Postgraduate School  
Monterey, CA 93943